



GE VERNOVA

PROFICY® SOFTWARE & SERVICES

ORCHESTRATION HUB

Release Notes

Proprietary Notice

The information contained in this publication is believed to be accurate and reliable. However, GE Vernova assumes no responsibilities for any errors, omissions or inaccuracies. Information contained in the publication is subject to change without notice.

No part of this publication may be reproduced in any form, or stored in a database or retrieval system, or transmitted or distributed in any form by any means, electronic, mechanical photocopying, recording or otherwise, without the prior written permission of GE Vernova. Information contained herein is subject to change without notice.

© 2024 GE Vernova and/or its affiliates. All rights reserved.

Trademark Notices

“VERNOVA” is a registered trademark of GE Vernova. “GE VERNOVA” is a registered trademark of GE Aerospace exclusively licensed to GE Vernova. The terms “GE” and the GE Monogram are trademarks of GE Aerospace and are used with permission.

Microsoft® is a registered trademark of Microsoft Corporation, in the United States and/or other countries.

All other trademarks are the property of their respective owners.

We want to hear from you. If you have any comments, questions, or suggestions about our documentation, send them to the following email address:
doc@ge.com

Table of Contents

- Key Features..... 1
 - Overview 1
 - Introduction 1
 - Design Flow..... 2
 - Orchestration Hub Flow..... 3
 - Installer 3
 - L4 Systems 3
 - Orchestration Hub..... 3
 - L2 Systems 3
 - Plant Application Multi Version Support..... 3
 - Plant Application Multi-site Connect 3
 - Variance Log Analytics..... 4
 - E-signature..... 4
 - Localization..... 4
 - Customization of column names 4
 - Enterprise Edition 4
 - Standard Edition..... 5
- System Requirements..... 5
 - Prerequisites 5
 - Denodo..... 5
 - Software Requirements 5
 - Supported Operating Systems 6
 - Hardware Requirements 6
 - Compatibility with Other GE Products 6
 - Open Defects 1

Key Features

Overview

The manufacturing industry, especially process manufacturing, is constantly trying to differentiate and innovate with an intent to maintain and grow their consumer base. This drives the need for constant innovation which introduces a high degree of variability in the daily manufacturing process. Most of the manufacturing customers struggle to manage this variability effectively and that becomes a cause for inefficiencies in their production. The greater the number of products and/or regulatory standards that these manufacturing facilities have to deal with, the larger the problem of being out of synch with the latest product manufacturing information.

Introduction

Proficiency Orchestration Hub enables manufacturing customers to stay in synch with the constant updates to product manufacturing information. The solution provides out-of-the-box tools to unify product manufacturing information from disparate data systems like ERP and PLM, transforms and organizes this raw business-oriented information into production-ready formats like recipes and specifications, and orchestrates the information across the customer's factory floor systems at a single site or multiple facilities.

Proficiency Orchestration Hub 2022, which first released in January 2022, focuses on the first foundational theme of Manufacturing Product Data Management (mPDM). The 2023 release of Orchestration Hub focuses on the following customer problems to solve: production delays, errors and rework due to lack of up-to-date product data in production systems; quality variability due to ad-hoc modifications and lack of visibility into the cause of modifications; and inability to reduce non-productive time due to manual efforts trying to execute standard production work.

Design Flow

Process Flow Diagram for Product Orchestration Hub:

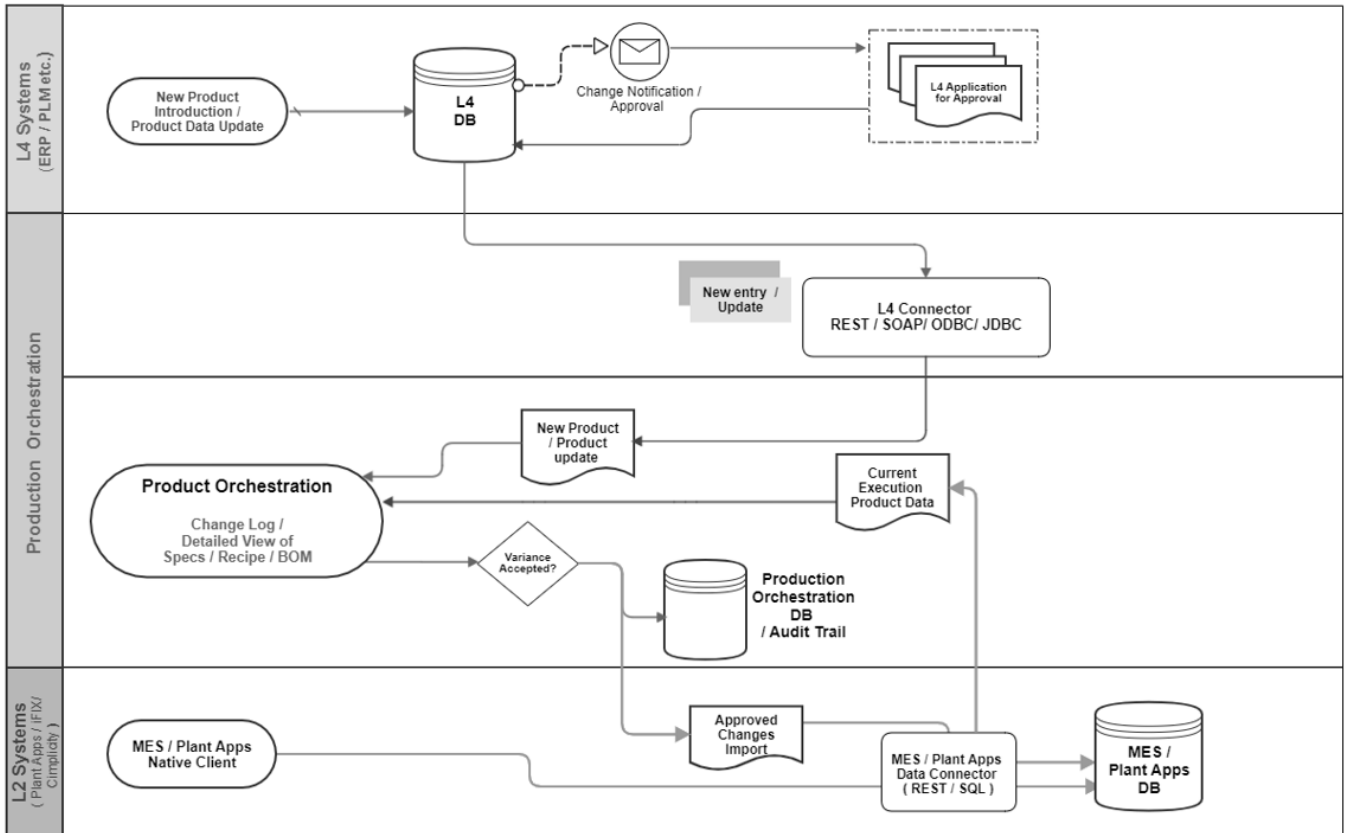

Orchestration Hub Flow

Let's discuss the design/flow/route of our Orchestration Hub:

Installer

To install the Orchestration Hub software, it will start with installer which requires couple of things as pre-requisite which include Operations Hub, Plant Applications, Proficy Authentication (UAA) with configuration details as details would be required by installer to install and make necessary connection to perform the operations.

L4 Systems

Under L4 system any update on new product introduction or update on existing products got for L4 Application approval once that's done same comes to Orchestration Hub.

Orchestration Hub

Here Orchestration Hub catches new entry using L4 Connector, and then the same goes to our application to discuss all the logs, detailed view of our recipe/specs if the variance is approved and accepted the changes goes to MES/Plant Applications native Client.

L2 Systems

In L2 System Plant Applications approved changes reports directed towards MES/Plant Applications data connector and then lands to Plant Applications database.

Plant Application Multi Version Support

Orchestration Hub will be able to connect and update the changes coming from the L4 systems for multiple versions of Plant Applications. Plant Application version 6.3, 7.0, 8.0, 8.1, and 8.2 is supported by Orchestration Hub. You can connect to any version of Plant Applications without making any additional comments during the installation phase.

Plant Application Multi-site Connect

Orchestration Hub will be able to connect to multiple Plant Application sites located at different locations. You can update the site details in a prescribed format and review the changes coming from the L4 systems. Multi-site functionality is available for the Enterprise edition only.

Variance Log Analytics

Variance log application will be able to capture all the logs of actions performed in the Orchestration Hub. User can see this data in the form of grid and charts.

E-signature

Orchestration Hub will be able to authorize the user who is publishing the changes to plant applications via electronic signature.

Localization

Orchestration Hub supports translation to English Japanese, Chinese and German languages. It picks the default language from your browser and our application shows up in the same language.

Customization of column names

Orchestration Hub supports customization of column names in grids. User can update headers of fields as per his continece.

Enterprise Edition

Orchestration Hub Enterprise edition provides user access to 3 applications:

1. Enterprise Connect

The Enterprise connect application provides a user interface to review the changes coming from the L4 systems and to update Plant Applications with the approved changes.

New product addition and updating the expiration date of BOM functionality is also present in the Enterprise connect

2. Plant Connect

Plant connect application provides user interface to update Central Plant Specification details.

It is not dependent on Denodo

3. Variance Management

Variance management application provides user interface to view all the changes that has been reviewed and updated in the Plant application. Various filters help to organize the data and the data can be exported as well in CSV format

Standard Edition

Orchestration Hub Standard edition provides user access to Plant connect and Variance management

Standard edition does not require Denodo for its operations

System Requirements

Prerequisites

The following software needs to be pre-installed and configured for Product Orchestration:

- Operations Hub 2.1 or higher installed on any machine, with Proficy Authentication (UAA) required for authorization and authentication.
- Plant Applications 6.3 or higher (SOADB) installed on any machine.
- Microsoft® SQL Server OLEDB Driver 18.
- Running instance of Denodo VDP 8.0 or higher with installed license file.
- Microsoft® SQL Server executed with default schema setup script executed.

Denodo

Orchestration Hub uses the Denodo data virtualization platform for building application integration or generic connector service. This platform can be readily extended to pull structured and unstructured data from disparate data sources (ERP/SAP/Oracle/IBM/PLM).

- Denodo is a key contributor for Product Orchestration Hub and is required as pre-requisite. Denodo includes multiple setup steps.
- Detailed steps for installation can be found in Product Orchestration Installation and Configuration Guide.

Software Requirements

- Operations Hub 2.1 or later. Operations Hub should already be installed and configured before you install Orchestration Hub.

- Proficy Authentication (UAA) must be installed along with Operations Hub is installed (or remotely connected).
- Plant Applications 6.3 or later. Plant Applications should already be installed, configured, and added as the application backend in Operations Hub before you install Orchestration Hub.
- Microsoft® SQL Express 2019 is a prerequisite for installation.
- Denodo should be downloaded and installed with license file along with 'Denodo Virtual DataPort 'service should be up and running. (Refer to Denodo Installation section for help on setting up Denodo).

Supported Operating Systems

You can install Orchestration Hub on the following operating systems:

- Microsoft® Windows Server 2016
- Microsoft® Windows Server 2019
- Microsoft® Windows Server 2022

Hardware Requirements

Orchestration Hub with connection to Plant Applications has similar requirements as Operations Hub:

- Minimum specification of 4 Core 2 GHz Processor with 16 GB RAM 2333 MHz
- Recommended 32G 2600MHz and an 8-core CPU 2Ghz –4GHz for better performance

Compatibility with Other GE Products

Product	Required Version
Plant Applications	6.3 and higher
Operations Hub	2.1 and higher
Proficy Authentication (UAA)	2.1 and higher
Denodo	8.0



Open Defects

Defect Description	Defect Id
Spec in Enterprise Connect: Spec selection in Enterprise Connect is allowing multiple selections for same (Property and Specification) selection.	DE195467
Electronic Signature: E-Signature Performer in audit trail is updating as null when user is not present Plant Application	DE195372
Installer - NodeUIApp and Tomcat are not getting uninstalled post uninstallation	DE193756
Installer - Getting warning message for Posting Utility even when we have Orchestration Hub entry in Operations Hub	DE193757
Enterprise Connect: Undoing all changes separately is not reverting accept all button	DE194710
E-Signature: Authentication timeout message is showing up only when user click on e-sign submit button.	DE194910
E-signature: session is not destroying on log out	DE195206
Plant Connect: Characteristic search is showing wrong behavior	DE195418
Enterprise connect When user is on confirm action popup for update expiry date UI tainted and user able to do other actions.	DE195426
Audit Trial- Number of the column should be in sync for Enterprise connect, Plant Connect and Audit Trial	DE195282

Direct upgrade from existing application to higher versions is not supported. User must uninstall existing version of the application and OH Tomcat from the control panel and reinstall the latest version of the application	DE198844
Plant Connect: Comments are not inherited from Parent characteristics. (TORAY-OBSERVATION)	DE197775
Plant connect: User should not be able to publish and Child level validation should fail (for spec-limit with bigger value) when parent level (Target) spec-limit is updated with smaller value from parent side	DE198183

About GE

GE (NYSE: GE) is the world's Digital Industrial Company, transforming industry with software-defined machines and solutions that are connected, responsive and predictive. GE is organized around a global exchange of knowledge, the "GE Store," through which each business shares and accesses the same technology, markets, structure and intellect. Each invention further fuels innovation and application across our industrial sectors. With people, services, technology and scale, GE delivers better outcomes for customers by speaking the language of industry.