



GE VERNOVA

Asset Performance Management

APM Classic

V4.6.11.0.0

APM Connect

Contents

Chapter 1: Overview	1
About APM Connect	2
Chapter 2: About NextGen ETL	3
About NextGen ETL Integration Platform	4
Terminology	4
Architecture	5
Chapter 3: NextGen ETL Installation	7
Installation checklist	8
System Requirements	8
Install and Configure Local Atom	10
Process Customization from Process Libraries	20
Install and Configure Southbound Service	21
Configuration for Customizations	38
IRDB Configuration Examples	46
Automated Data Loader Service Installation	50
Chapter 4: NextGen ETL Account Management	53
Account Management	54
Access the Account Settings Page	54
User Management	54
Account Roles	54
User Addition, Editing, Removal	55
Account Advanced Security Settings	56
Chapter 5: Data Loaders	57
General Information	58
APM Family Data Loader	59
Equipment and Functional Location Data Loader	69

Taxonomy Data Loader	86
Work History Data Loader	93
APM Connect Data Loader Logs	108
Chapter 6: Automatic Data Loader	112
About the Automatic Data Loader Job	113
Chapter 7: EAM Adapter	114
EAM Adapters	115
System Architecture for EAM Adapter	115
Chapter 8: General Reference	117
APM Connect Version Compatibility Table	118
The Automatic Data Loader Directories	119
About Time Zone Data	121
Support for Multiple Source Systems	122
Support for Multiple Culture Settings from a Single Source System	123

Copyright Digital, part of GE Vernova

© 2025 GE Vernova and/or its affiliates. All rights reserved.

GE, the GE Monogram, and Predix are trademarks of General Electric Company used under trademark license.

This document may contain Confidential/Proprietary information of GE Vernova and/or its affiliates. Distribution or reproduction is prohibited without permission.

THIS DOCUMENT AND ITS CONTENTS ARE PROVIDED "AS IS," WITH NO REPRESENTATION OR WARRANTIES OF ANY KIND, WHETHER EXPRESS OR IMPLIED, INCLUDING BUT NOT LIMITED TO WARRANTIES OF DESIGN, MERCHANTABILITY, OR FITNESS FOR A PARTICULAR PURPOSE. ALL OTHER LIABILITY ARISING FROM RELIANCE UPON ANY INFORMATION CONTAINED HEREIN IS EXPRESSLY DISCLAIMED.

Access to and use of the software described in this document is conditioned on acceptance of the End User License Agreement and compliance with its terms.

Chapter 1

Overview

Topics:

- [About APM Connect](#)

About APM Connect

The APM Connect system provides the means to load data from the Industrial Internet of Things (IIOT) into APM.

The system uses data loaders and adapters to establish a data flow between APM and EAM systems, Field Service Management systems, and other assets. The APM Connect context file defines the communication path between the IIOT and APM.

Note: For information about the APM Connect versions corresponding to APM versions, refer to the [APM Connect Version Compatibility Table](#) on page 118.

APM Connect Next Generation ETL is the new integration tool in replacement to the existing technology stack. The new model provides for common workflow development, deployment, execution, and monitoring with remote management option.

You can ingest data to APM using one of the following methods:

- [Using Data Loaders Manually](#)
- [Using Automatic Data Loaders](#)
- [Using EAM Adapters](#)

Chapter 2

About NextGen ETL

Topics:

- [About NextGen ETL Integration Platform](#)
- [Terminology](#)
- [Architecture](#)

About NextGen ETL Integration Platform

APM Connect uses the Boomi Integration Platform to provide NextGen Extract Transform Load (ETL) capabilities to streamline the data integration process. This Integration service provides essential tools and connections to link data and automate workflows seamlessly across your distributed environment. You can:

- Access an intuitive interface
- Automate data mapping tools
- Build process recipes
- Accelerate your process by using a library of connectors

The integration process comprises three main stages:

- **Build:** Create workflows to integrate data sources, apply necessary transformations based on the destination requirements, and transmit the data to the destination system.
- **Deploy:** Deploy the developed workflows to your runtime environment. These workflows will then facilitate data integration between the source and destination systems.
- **Manage:** Manage the lifecycle of your developed workflows, including manual and scheduled execution, scheduling modifications, and monitoring workflow execution logs.

Terminology

This document uses the following terminologies:

Term	Definition
Integration process	A business process or a transaction level interface between two or more systems. An Integration process contains all the components required to run your processes from end to end, including connectors, transformation rules, decision handling, and processing logic.
Atom	An Atom is a minimalistic runtime environment that is remotely managed from the Boomi Integration Platform. In APM Connect, a Boomi Atom is deployed on-premise. Currently, Cloud Atom deployment is not supported. As part of an Atom deployment, integration processes are made available to your Atom.
Process	A workflow that integrates data between a source and a destination.
Execution	A workflow execution in the runtime environment.

Term	Definition
Integration Packs	<p>Content developed by GE Vernova for integrating your APM solution with specific source systems. This content contains the workflows necessary to extract data from the source system and deliver it to APM for use in your asset management work processes. The APM Connect Release Integration pack and process folders contain the following workflows and their dependencies:</p> <ul style="list-style-type: none"> • [Main]Extraction_Wrapper: For Running SAP interface • [Main]Maximo_Extraction_Wrapper • [Main]IR_Create_Intermediate_Repository • [Main]IR_Add_Source_System • [Main]IR_Add_Postgres_Functions
Extensions	<p>Extensions are variables that are defined for each environment and Integration Pack deployment. These variables are used by the Integration Pack for a specific environment to dynamically allow an end user to configure parameters in the workflow that will be unique to their individual environment. The use of extensions in integration packs allows for standard workflow content without the need to rebuild and deploy a workflow that is unique for each environment and customer. In the APM Connect Integration packs, parameters for multiple extensions are defined and utilized.</p>
Environment	<p>Environments provide you a greater control over change management and support different connection configurations using extensions. An environment is a workspace that you create and use for testing or production purposes. When you add an environment, you must select a classification, Production or Test.</p>

Architecture

The following image shows the architecture for on-premises environment.

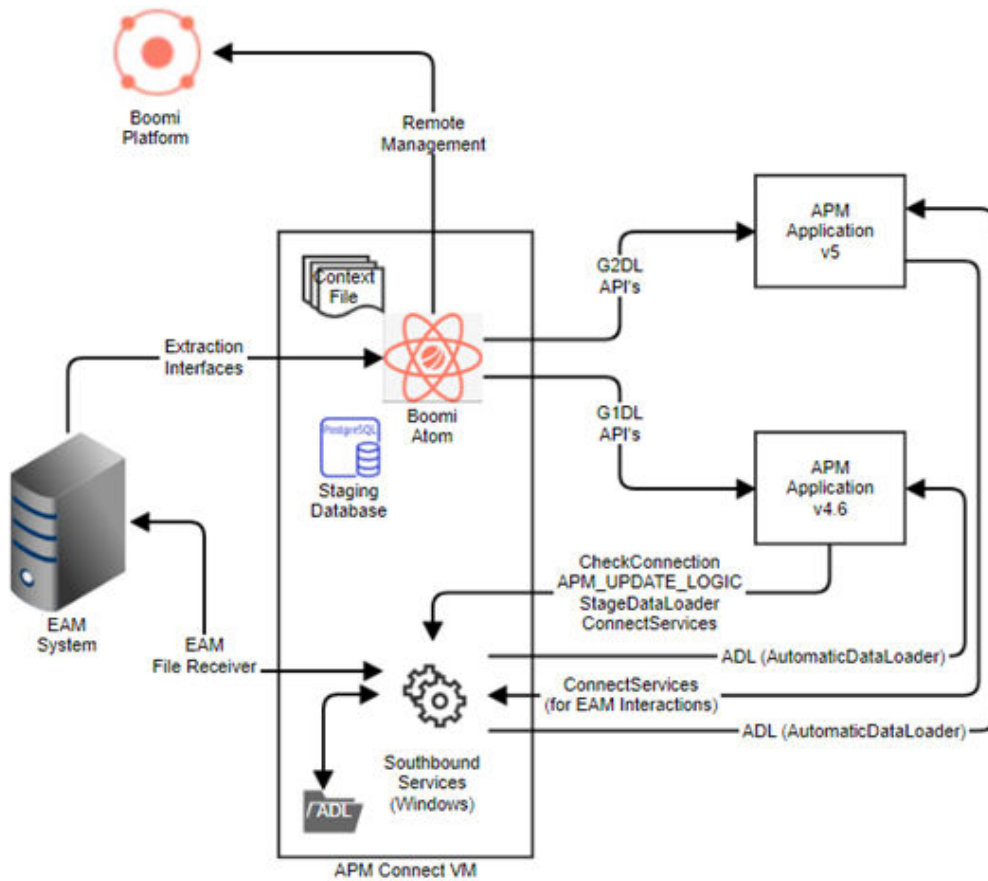

In an on-premise architecture, the Boomi Atom runs on the APM Connect server to facilitate extractions from the EAM system. This functionality is supported by configurations specified in the Context File and the Staging Database. The Boomi Atom management including deployments, scheduling, and troubleshooting, is conducted through the Platform. Additionally, for interfaces from APM to the EAM system, a windows-based Southbound Service facilitates various Southbound transactions.

Chapter 3

NextGen ETL Installation

Topics:

- [Installation checklist](#)
- [System Requirements](#)
- [Install and Configure Local Atom](#)
- [Process Customizations from Process Libraries](#)
- [Install and Configure Southbound Service](#)
- [Configuration for Customizations](#)
- [IRDB Configuration Examples](#)
- [Automated Data Loader Service Installation](#)

Installation checklist

Installation Checklist

This section provides details on performing tasks that you must complete for:

- EAM Integration
- Data Loader Integration

Step	Task	EAM Integration	Automatic Data Loader Integration
1	Validate the System Requirements	This step is required.	This step is required.
2	Set up and configure Local Atom (Integration Job Deployment)	This step is required.	Not required.
3	Install and configure Southbound Service	This step is required only if the data loader writes back to EAM or if you are using Automated Data Loaders.	This step is required.
4	Configure Northbound and Southbound Data Extraction SAP Mapping	This step is optional.	Not required.
5	Configure Postgres	This step is required.	This step is required.

System Requirements

Hardware Requirements

A single Atom must process high volumes of data, therefore, the server must meet the following system requirements:

Processor	Dual 64-bit processors or higher (with 8 or 16 Cores) More processors allow for increased, simultaneous process runs
Memory	32 GB of RAM (minimum 8 GB dedicated to the Atom) More RAM allows for increased, simultaneous process runs
Hard disk	100–200 GB of hard disk space

Software Requirements

The following software components are required:

- Atom: An Atom must be installed within your network to connect to source systems and process the data into APM applications hosted on On-premise APM . The Atom will process and transmit data within your network boundary.
 - Multiple runtime environments can be installed on the same operating system.
 - A stable and high-speed internet connection is required.

- Network connectivity between the source and destination systems must be enabled.
- The installation path for Atom must not contain any unicode characters.
- Ensure that the operating system hosting Atom and any attached storage devices have synchronized system clocks.
- Postgres (included as part of the installer for Southbound Services).
- SAP integration
 - You must install the open-source library, [sapnwrfc](#) for .Net Core framework to connect to SAP. This open-source library requires the [SAP NetWeaver RFC Library 7.50 SDK C+ +](#) binaries to be installed locally.
 - The following files must be copied to the Southbound Service installation folders:
 - icudt50.dll
 - icuin50.dll
 - icuuc50.dll
 - libsapucum.dll
 - libsapucum.lib
 - sapnwrfc.dll
 - sapnwrfc.lib

Supported Operating Systems

Operating system	Version
Windows 64-bit	APM Connect supports Windows Server 2016, 2019, or 2022

Java Runtime

Java (for Windows and Linux)	Java 8 or 11 (Preferred)
Java runtime (for Windows and Linux)	Support for the following Java Runtime Variants: <ul style="list-style-type: none"> • Java 8 <ul style="list-style-type: none"> ◦ Oracle Java ◦ Amazon Corretto OpenJDK • Java 11 <ul style="list-style-type: none"> ◦ Amazon Corretto OpenJDK <p>Note: We recommend that you use the Java distribution from the remote management platform such that Java updates can be managed remotely (including automation).</p>
Java Information Panel	Boomi provides a view to Java in use by the Atom in the management view. <ul style="list-style-type: none"> • Details are available with the Atom online or offline • Manual Java updates can be executed • The option to opt the Atom into automatic Java updates can be turned on or off

Required Service Ports

To provide communication between APM Connect server and other systems, ensure that the following ports are open.

Port Numbers	Description
5013/8040 (Ingress for the Service)	The service can listen on any port as per its configuration. It is recommended to use a unique port that would not interfere with other standard applications running on the server where it is hosted.
80, 9080, 8879, 9043, 9044, 9060, 9061, 9430, 9443, 139, 50000, 50005, 3300	Used for SAP and Maximo Interfaces.
443, 8080, 8005, 7000, 7001, 7777, 7555, 1099, 8040, 8101, 9001, 44444, 5432, 443, 61616, 5013	Used for APM Interfaces.

Install and Configure Local Atom

Pre-deployment Checklist

The following table outlines the steps that you must complete prior to deploying and configuring Atom for the first time.

Step	Task
1	Sign in to the Boomi Platform Account provisioned by GE Vernova.
2	Verify system availability for Atom installation, ensuring all necessary configurations are correctly set up.

Step	Task
3	Validate access and permissions for both the source and destination systems: <ul style="list-style-type: none"> • Conduct connectivity checks for the Boomi platform. • Ensure access to the PLSAP folder. • Validate user permissions.
4	Install PostgreSQL database and make required configuration change in the <code>pg_hba.conf</code> file. For more information, refer to Configure PostgreSQL .

Set up your environment

About This Task

Follow these steps to create a test and production environment.

Procedure

1. Sign in to your Boomi Integration Platform account.
2. Navigate to **Manage > Atom Management**.
The **Environment** page is displayed.
3. On the left navigation panel, select **New**, and then select **Environment**.
The **Add Environment** window appears.
4. Enter a name for your environment in the **Name** field.
5. From the **Environment Classification** list, select **Test** as the environment type.
6. Select **Save**.
A new Test environment is created, visible in the left navigation pane.
7. Repeat steps 3-6 to create a Production environment, selecting **Production** as the **Environment Classification**.

Results

Two new environments, one for testing and one for production, are created in the left navigation panel with the names you provided.

Download Atom Installer

Procedure

1. Sign in to your Boomi Integration Platform account on the machine where you want to install Atom.
2. Navigate to **Manage > Atom Management**.
3. Select **New** in the left navigation panel, then select **Atom**.
The **Atom Setup** window is displayed.
4. In **Setup Preference**, select **Local** as the preference and select the appropriate operating system in **Operating System**.
5. **Optional:** Expand **Security Options** to generate an installer token, required during Atom installation.
6. Select the validity duration for the token from the **Token Valid For** list.
7. Select **Generate Token** to create a unique installer token. Copy and save the token for later use during Atom installation.

8. Select **Close**.
9. Select **Download Installer** and then select **Save File**.
The installation file is downloaded to your computer.

Install Atom on Windows

Procedure

1. Sign in as a user with administrative privileges on the computer where you plan to install Atom.
2. Locate the folder containing the downloaded Atom installer file.
Note: Boomi recommends not running anti-virus tools or scans on the Atom installation folder. This is because for Boomi to operate normally, it needs access to the Atom installation folder, where Boomi moves files and modifies them. For more information, refer to the [Boomi documentation](#).
3. Run the installer with administrative privileges.
A prompt appears, requesting permission to make changes to your computer.
4. Select **Yes**.
The **Setup – Atom** window appears.
5. Select **Next**.
The **User Information** page appears.
6. Select one of the following authentication methods for the Platform to authenticate Atom:
 - **User Name and Password:** Enter your Platform username and password
 - **Token:** Enter the installer token generated in [Step 5](#).
7. Enter a name for the Atom in the **Atom Name** field.
8. **Optional:** If your local computer uses a proxy to connect to the internet, select **Use Proxy Settings** and enter the required details, provided by your network team.
9. Select **Next**.
The **Accounts** page appears.
10. Select your account and select **Next**.
The **Environment** page appears.
11. Select the environment created in the [Set up your environment](#) step and select **Next**.
The **Information** page appears.
12. Review the installation details and select **Next**.
The **Select Destination Directory** screen appears.
13. Select **Browse** to navigate to the desired installation directory and select **Next**.
The **Select Start Menu Folder** page appears.
14. Select **Create a Start Menu folder** checkbox and select **Next**.
The installation process begins.
Note: If you receive an error message regarding a JRE file download error during installation, ignore the error and proceed with the installation.
15. Select **Finish** to complete the setup.

Next Steps

Validate that Atom is installed on your computer:

- Open `Services.msc` and validate that the Atom service is installed.
- You can view the Atom status by selecting **Manage > Atom Management**

Note: For more details on the Atom configuration options, refer to the Boomi Documentation available in the Remote Management platform.

Install Integration Pack

Procedure

1. Sign in to your Boomi Integration Platform account.
2. Navigate to **Deploy > Integration Packs**.
3. Select the **Browse Integration Packs** button.
The **Browse Integration Packs** window appears, displaying a list of Releases assigned to your account.
4. Select **View** for the release that you want to install.
The details about the release appear.
5. Select **Install**.
6. Optionally, in the **Choose New Process Name (optional)** field, provide either the baseline release number or a custom name for your project.
7. Select **Complete Installation**.
8. After the Integration Pack installation is complete, select **Close**.

Results

The Integration Pack is now installed on your computer.

Attach Environment to an Integration Pack

Procedure

1. Sign in to your Boomi Integration Platform account.
2. Navigate to **Deploy>Integration Packs**.
The **Integration Packs** page appears.
3. Select the previously installed Integration pack.
4. From the **Attached Environments** and **Unattached Environments** fields, select the test environment from the **Unattached Environment** list.
5. Select **<<Attach Selected** button to move the selected Integration pack from left **Unattached Environment** list to **Attached Environment** list. The Integration pack is attached to your selected Environment.
The selected environment now appears on the **Attached Environment** list for the Integration pack.

Configure Connection Settings

Procedure

1. Sign in to your Boomi Platform Integration account
2. Navigate to **Manage > Atom Management**.
In the left pane, your environment (Test) with the attached atom is displayed.
3. Select your Test environment and select **Environment Extension**. The **Extensions** window appears.
 - a) In the **Process Type** dropdown list, select **Multi Installation Integration Packs**.

Extensions

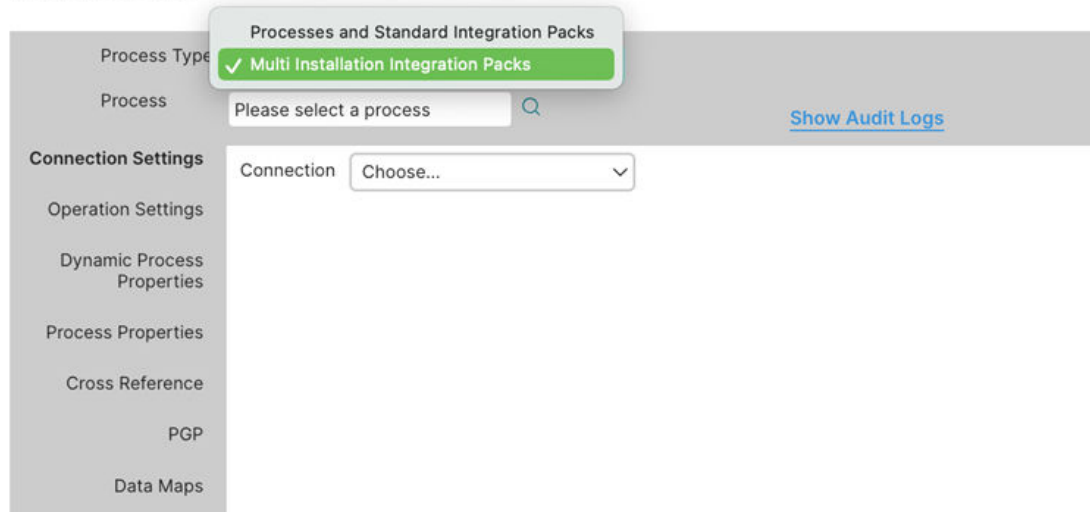

- b) Select **Process** and then select the search button to navigate to the Integration pack artifact in the navigation tree. (**Integration pack** → **Release_*** → **[Main] Extraction Wrapper**). For example, the following image shows the navigation tree for release 5.1.0.0.0.

Extensions

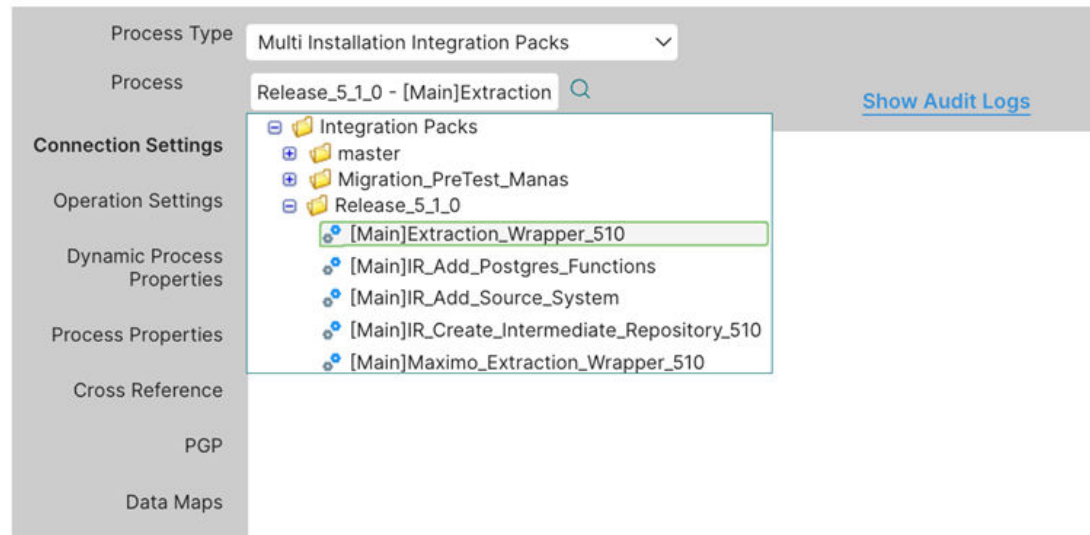

- c) Select **Connection Settings**. In the **Connection** dropdown list, select the appropriate connection, as shown in the following screenshot.

Extensions

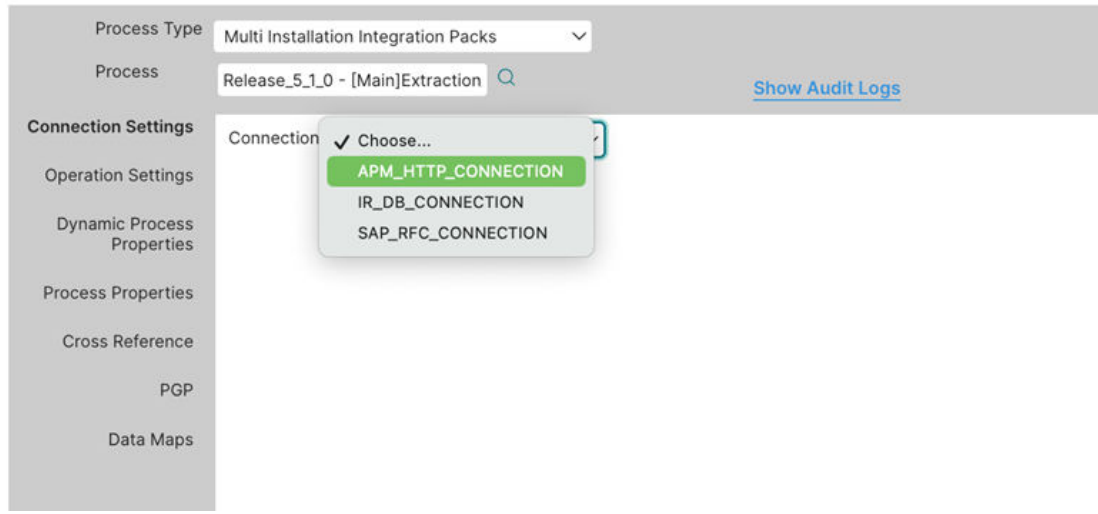



- APM_HTTP_CONNECTION
 - URL : Enter `http://{APM_API_APP_SERVER}`
 - Connect Timeout
 - Read Timeout
 - Use Basic Authentication
 - User: APM_USERID
 - Password: APM_PASSWORD
 - Use Client Authorization
 - Client SSL Certificate
 - Use Trusted SSL Certificate
 - Trust SSL Server Certificate
- IR_DB_CONNECTION
 - User : IR_USERID
 - Password :IR_PASSWORD
 - Connection URL : the URL will be: `jdbc:postgresql://{IR_HOST}:{IR_PORT}/{IR_DATABASE}`
 - Enable Pooling
 - Maximum Connections
 - Maximum Idle Time (sec)
- SAP_RFC_CONNECTIONS
 - Connection Type : select APPLICATION SEVER HOST
 - User Name : SAP_USERID
 - Password :SAP_PASSWORD
 - Server : SAP_HOST
 - Client : Enter SAP_CLIENT
 - System Number : SAP_SYSTEM_NUMBER
 - Group Name
 - Maximum Idle Connections
 - Maximum Active Connections
 - Idle Time

- Gateway Host
- Gateway Service
- Enable Low Latency Logging
- Additional Connection Settings
 - SAP-PI has the below additional extension parameters:
 - URL
 - Connect Timeout
 - Read Timeout
 - Use Basic Authentication
 - User
 - Password

d) Select **Process Properties** and enter values for the following parameters:

- i. SYSTEM_TO_RUN : Context file folder name (typically CMMS_ID)
- ii. CONFIG_FILE_DIR : Directory path to the folder where the context file resides
- iii. RUN_EQUIPMENT : Select TRUE/FALSE
- iv. RUN_FLOC : Select TRUE/FALSE
- v. RUN_WORKHISTORY : Select TRUE/FALSE
- vi. RUN_STATIC_DATA : Select TRUE/FALSE
- vii. RUN_EQUIPMENT_TC : Select TRUE/FALSE
- viii. RUN_FLOC_TC : Select TRUE/FALSE
- ix. RUN_WMI : Select TRUE/FALSE
- x. RUN_PWORK : Select TRUE/FALSE
- xi. RUN_ASI_DATA : Select TRUE/FALSE

Connection Settings			
Operation Settings	RUN_EQUIPMENT	FALSE	<input type="checkbox"/> Use Default
Dynamic Process Properties	RUN_FLOC	FALSE	<input type="checkbox"/> Use Default
Process Properties	RUN_WORKHISTORY	FALSE	<input type="checkbox"/> Use Default
Cross Reference	CONFIG_FILE_DIR 	C:\APMConnect\Config\SAP-HAI	<input type="checkbox"/> Use Default
PGP	SYSTEM_TO_RUN 	S23-000	<input type="checkbox"/> Use Default
Data Maps	RUN_STATIC_DATA	TRUE	<input type="checkbox"/> Use Default
	Component_ID	60b7e231-978b-41ce-ae3a-14fc	<input checked="" type="checkbox"/> Use Default
	RUN_EQUIP_TC	FALSE	<input type="checkbox"/> Use Default
	RUN_FLOC_TC	FALSE	<input type="checkbox"/> Use Default
	RUN_WMI	FALSE	<input type="checkbox"/> Use Default
	RUN_PWORK	FALSE	<input type="checkbox"/> Use Default
	RUN_ASI_DATA	FALSE	<input type="checkbox"/> Use Default

Note: Ensure that you have only one file under one cmms_id folder and all the above details match with your APM Connect context files.

4. Select **OK**.
A notification appears indicating that your extension is saved.
5. Additional APM V5 configurations for new components:
 - a. For V5 tenant context file, enable `<ENABLE_G2DL_INGESTION>>true</ENABLE_G2DL_INGESTION>`
 - b. Update `MAX_FILE_WAIT_SEC` to 10 seconds: `<MAX_FILE_WAIT_SEC>10</MAX_FILE_WAIT_SEC>`
 - c. Navigate to the Atom installation directory and complete the following steps:
 - i. Open file `{Atom installation dir}\bin\atom.vmoptions` in text editor:
 - Update `Xmx512m` to `-Xmx16G`
 - Add `Dfile.encoding=utf-8`

Note: Each time you add a new Integration pack, set up the extension property against it.

Configure the Context File

Before You Begin

You should have imported the audit job.

About This Task

The context file provides the audit job with the information it needs to connect to ActiveMQ, IR, and APM.

Procedure

1. Navigate to the following folder: `C:\APMConnect\Config\<system>`.
2. Modify `ContextFile.xml` to indicate the values for your system.

Results

Parameter	Description	Default or Recommended Value
CONFIG_FILE_PATH	The path to the context file used for extraction.	Enter your unique value (for example, <code>C:\APMConnect\Config\ContextFile.xml</code>).
IR_HOST	Intermediary Repository host name.	Enter your unique value.
IR_DATABASE	Database for the dinolader job.	Enter your unique value.
IR_USERID	Intermediary Repository username.	Enter your unique value.
IR_PASSWORD	Intermediary Repository password.	Enter your unique value.
IR_SCHEMA	The schema in which the IR database will be created.	The default value is public.

Parameter	Description	Default or Recommended Value
IR_PORT	Intermediate Repository port.	Default value is 5432.
APM_USERID	The APM user ID.	Enter your unique value.
APM_PASSWORD	The APM password.	Enter your unique value.
APM_DATASOURCE	The name of the APM data source to which the data will be exported.	This is a required parameter. Enter your unique value.
APM_API_APP_SERVER	The name of the APM API server.	This is a required parameter. Enter your unique value.
APM_APP_SERVER	The name of the APM server.	This is a required parameter. Enter your unique value.
TRUSTSTORE_FILE	The directory path to the dinolader SSL configuration file.	Enter your unique value.
TRUSTSTORE_PASSWORD	The password for the keystore files.	Enter your unique value.
USE_SSL	Determines if SSL is used.	True: will use SSL. False: will not use SSL.
QUEUE_HOST	The host name of the APM ActiveMQ.	Enter your unique value.
QUEUE_PORT	APM ActiveMQ port.	Default port is 61616.
QUEUE_USER	APM ActiveMQ user.	Enter your unique value.
QUEUE_PASSWORD	APM ActiveMQ password.	Enter your unique value.
CMMS_ID	Enter your EAM system ID	Enter your unique value.

Configure PostgreSQL

To allow connections from the APM server to APM Connect, you must update the PostgreSQL networking configuration. This topic describes how to perform the configuration update.

Procedure

1. On the machine in which you installed APM Connect, navigate to your PostgreSQL installation files. By default, PostgreSQL is installed at the following location:

```
<root:>\Program Files\Postgres\11\data.
```
2. Locate the configuration file `pg_hba.conf`, and then right-click the file and open it in a text editor.
3. Navigate to the end of the document and locate the following line of text:

```
host all all 127.0.0.1/32 md5
```

4. Add the following line of code, as shown in the image.

```
host all all IP address of the APM Server md5
```

```

76
77 # TYPE DATABASE USER ADDRESS METHOD
78
79 # IPv4 local connections:
80 host all all 127.0.0.1/32 md5
81 host all all <APM IP address>/32 md5
82 # IPv6 local connections:
83 host all all ::1/128 md5
84 # Allow replication connections from localhost, by a user with the
85 # replication privilege.
86 #host replication postgres 127.0.0.1/32 md5
87 #host replication postgres ::1/128 md5
88

```

5. Save and close the file.

Note: For better security posture, we recommend that you restrict the PostgreSQL access to the APM server only.

Results

PostgreSQL is now configured to open the connection from the APM server.

Execute a Process Manually

Procedure

1. Sign in to your Boomi Platform Integration account.
2. Select **Manage > Process Reporting**.
The Process Reporting page opens.
3. Select **Execute Process** and select your Atom from the dropdown menu under the appropriate environment.
4. In the **Process** field, select the desired process from your installed Integration Packs, and then select the **Execute** button.
5. Select the File icon to either view or save the logs.

Schedule a Process

Procedure

1. Sign in to your Boomi Platform Integration page.
2. Navigate to **Manage > Atom Management**.
The **Atom Management** page appears.
3. Select the Atom under your Environment and select **Deployed Processes**.
4. Open the dropdown list of any deployed process and select **Edit Schedules**.
The **Scheduling** window appears.
5. Select the **Add** button.
6. Modify the schedule as required and select **OK**.
A **Scheduled Saved** notification appears.
7. Navigate to the Process reporting page to view an entry for your scheduled run.

Stop a Schedule

Procedure

1. Sign in to your Boomi Platform Integration page.
2. Select **Manage** and select **Atom management**.
3. Select your Atom and select **Deployed Processes**.
4. Select the dropdown arrow next to the intended process and select **Stop Schedules**.

Process Customizations from Process Libraries

About This Task

To customize an ETL job by extending GE Vernova baseline integration flows, create a folder and install the process libraries shared by GE Vernova for your account.

Procedure

1. Sign in to your Boomi Platform Integration account.
2. Select **Build**.
The **Build** page appears.
3. Select the three vertical dots at the root node of the folder hierarchy.
4. Select **New Folder**.
The **New Folder** dialog box appears.
5. Enter the folder name in the **Name** box. The folder name must start with **custom_** and include a suffix with the release number of the Process Library package being downloaded.
6. Select **Save**.
A new folder is created.
7. Return to the **Build** page.
8. Select **Browse Process Library**.
A window displaying all the process libraries shared with your account appears.
9. In the upper right corner of the window, under **Filter by Publisher**, select **GE Vernova**.
The search result displays the list of process libraries shared with your account. Each process library includes a suffix with the release version.
10. To install a specific process library for customization, select the **Install** button next to the process library name.
11. In the **Select Installation Location** field, select the new folder that you have created in [Step 6](#) and select **Install**.
12. After you install the process library, select the component you would want to extend to start editing the process.
13. After the editing is complete, you can deploy the process to an Atom.

Install and Configure Southbound Service

Overview

The installation package includes the setup of the Southbound Service from APM to the EAM system. This topic outlines the steps that you must complete to deploy and configure this module for the first time. These instructions assume that you have completed the steps for deploying the basic APM system architecture.

Note: This service can be deployed on the APM Connect Server, APM server, or a dedicated server. The service should have access to the APM Connect Postgres Staging Database.

Install Southbound Service

Before You Begin

Before you run the Southbound Service installer, you must ensure that:

- You have access to the Southbound Service installation package.
- You can access the APM server host URL and ActiveMQ from the server where the installation is planned.
- You have access to the Postgres IR database of the APM Connect server.

Prerequisites (for SAP integration only):

1. The SapNwRfc open source library requires the SAP NetWeaver RFC Library 7.50 SDK C++ binaries. Download them into the installation folder of the APMC Southbound Service. To do so:
 - a. Log in to the [SAP Software Center](#) using your SAP credentials (or search for SAP NW RFC SDK 7.5.0).
 - b. Download both the .zip files and extract the contents into the APMC Southbound Service installation folder. Override the DLLs if a Windows prompt appears.
2. On Windows, install the 64-bit version of the Visual C++ 2013 Redistributable package.
3. Install the [SapNwRfc open source library](#) for .Net Core framework to connect to SAP. This library requires the SAP NetWeaver RFC Library 7.50 SDK C++ binaries to be installed locally. Copy the following files to the APMC Southbound Service installation folder:
 - icudt50.dll
 - icuin50.dll
 - icuuc50.dll
 - libsapucum.dll
 - libsapucum.lib
 - sapnwrfc.dll
 - sapnwrfc.lib

Procedure

1. Sign in as a user with administrative privileges to the server where you plan to install the application.
2. Access the APM distribution package and then navigate to the folder where you downloaded the installer package.

3. Run `APMConnect-Base.exe` with administrative privileges.
The **Setup - APMConnect** window appears.

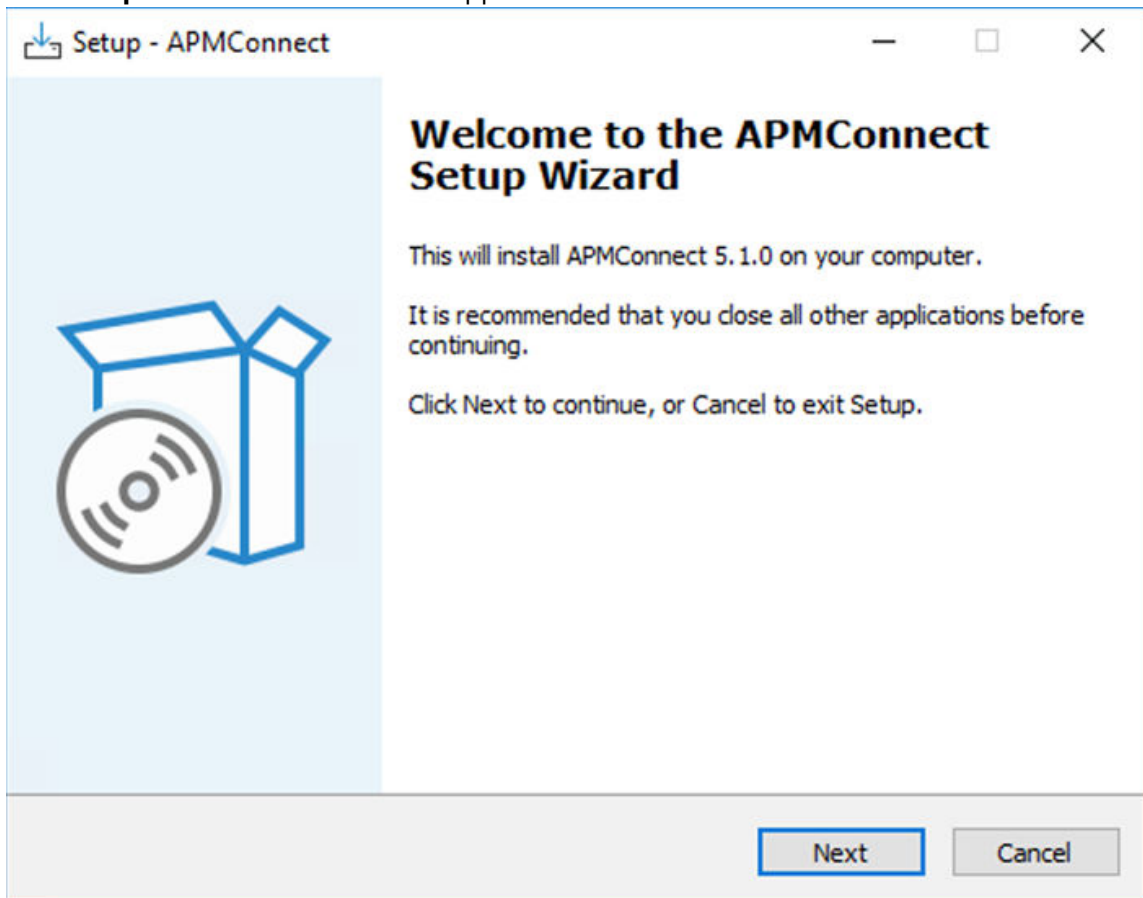

4. Select **Next**.
The **Select Destination Location** window appears.

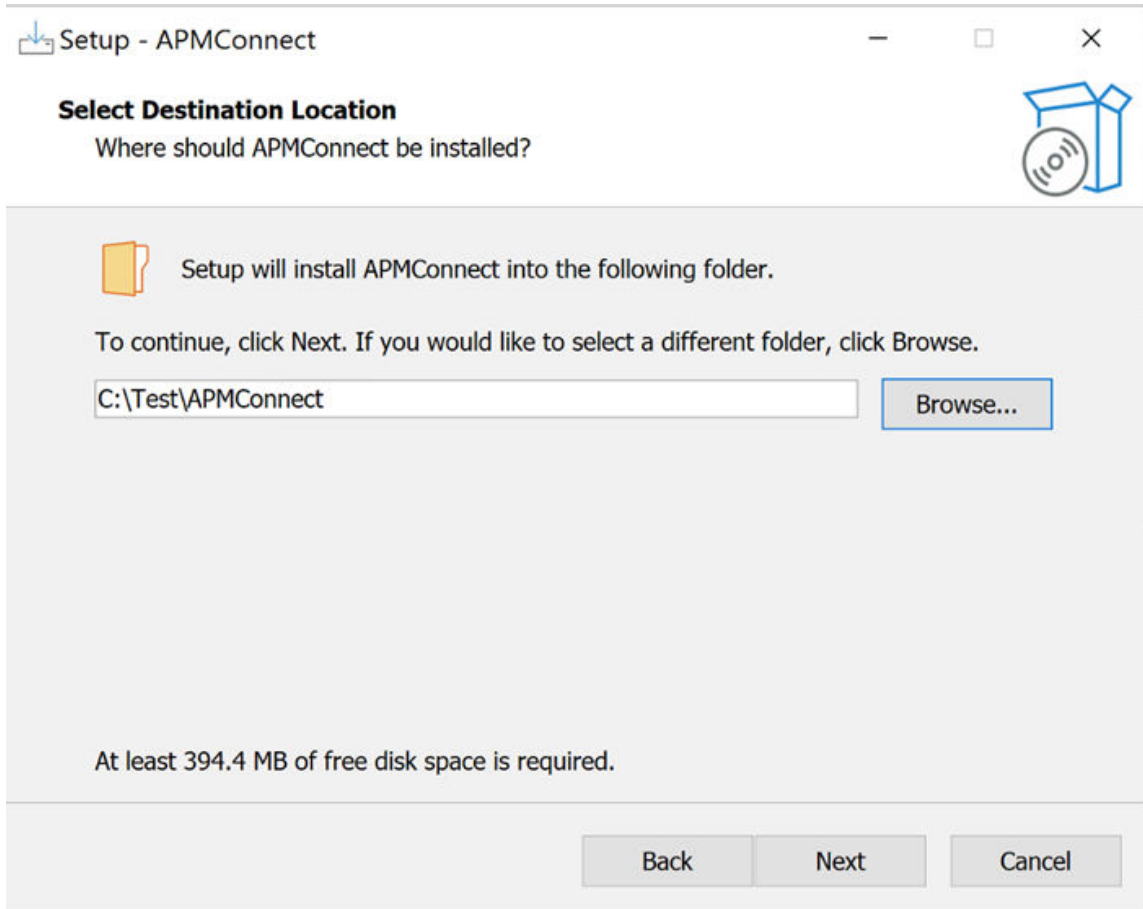

5. Select **Browse** to navigate to the destination folder where the services must be installed.
6. Select **Next**.
The **Select Components** window appears.
7. Select the components you wish to install:
 - a. Install PostgreSQL: Used for the Intermediate Repository. Clear the checkbox if already in use.
 - b. Install Boomi: Select if Boomi is used without internet connectivity.
 - c. Install APM Connect Southbound Service: Select for the Southbound Interfaces.

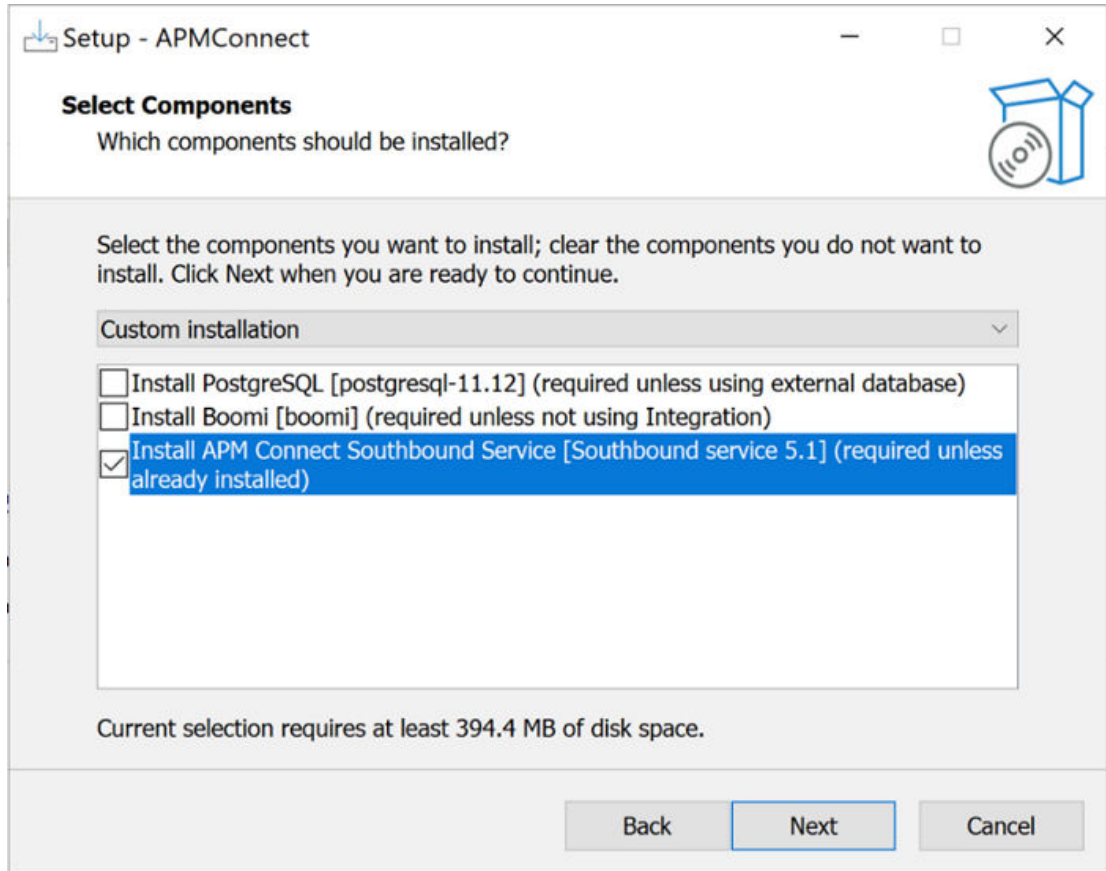

8. Select **Next**.
The **Select Start Menu Folder** window appears.

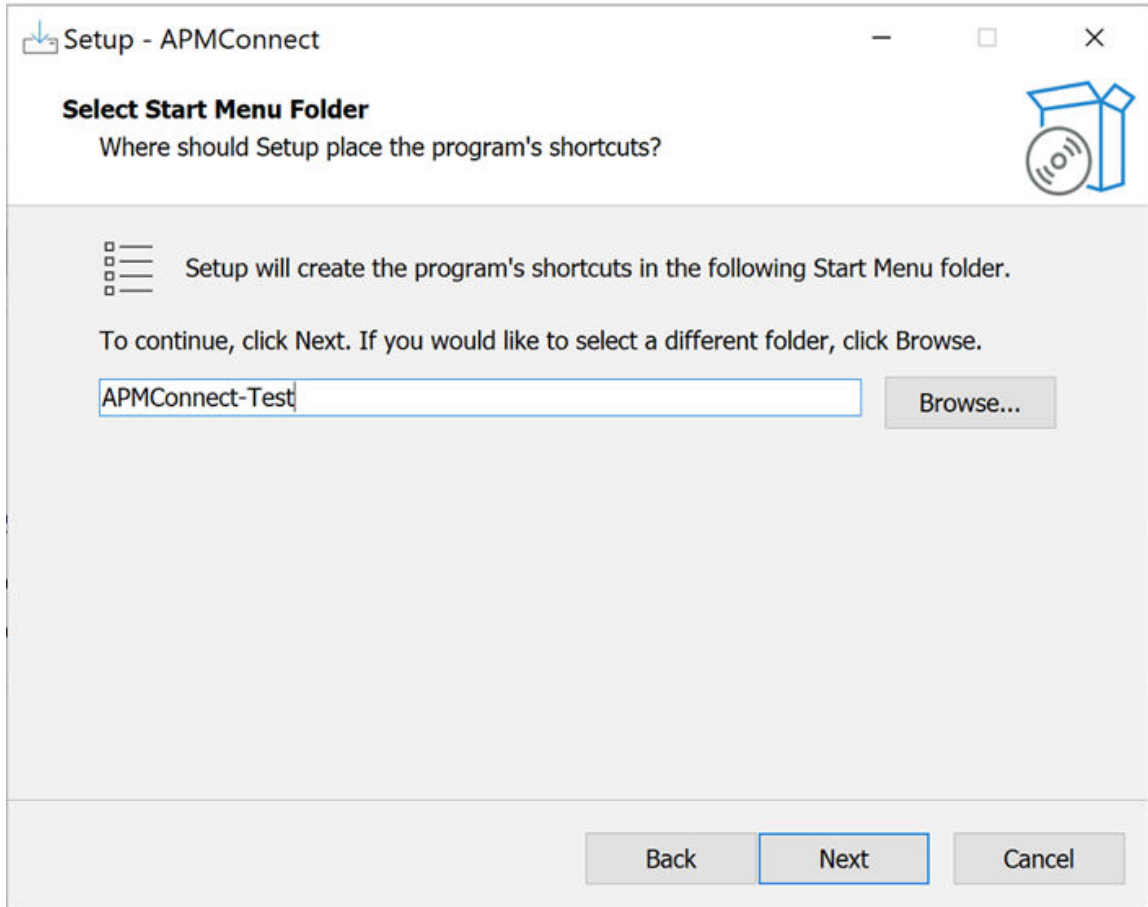

9. Select **Browse** to select the folder for placing shortcuts, then select **Next**. The **Ready to Install** window appears.

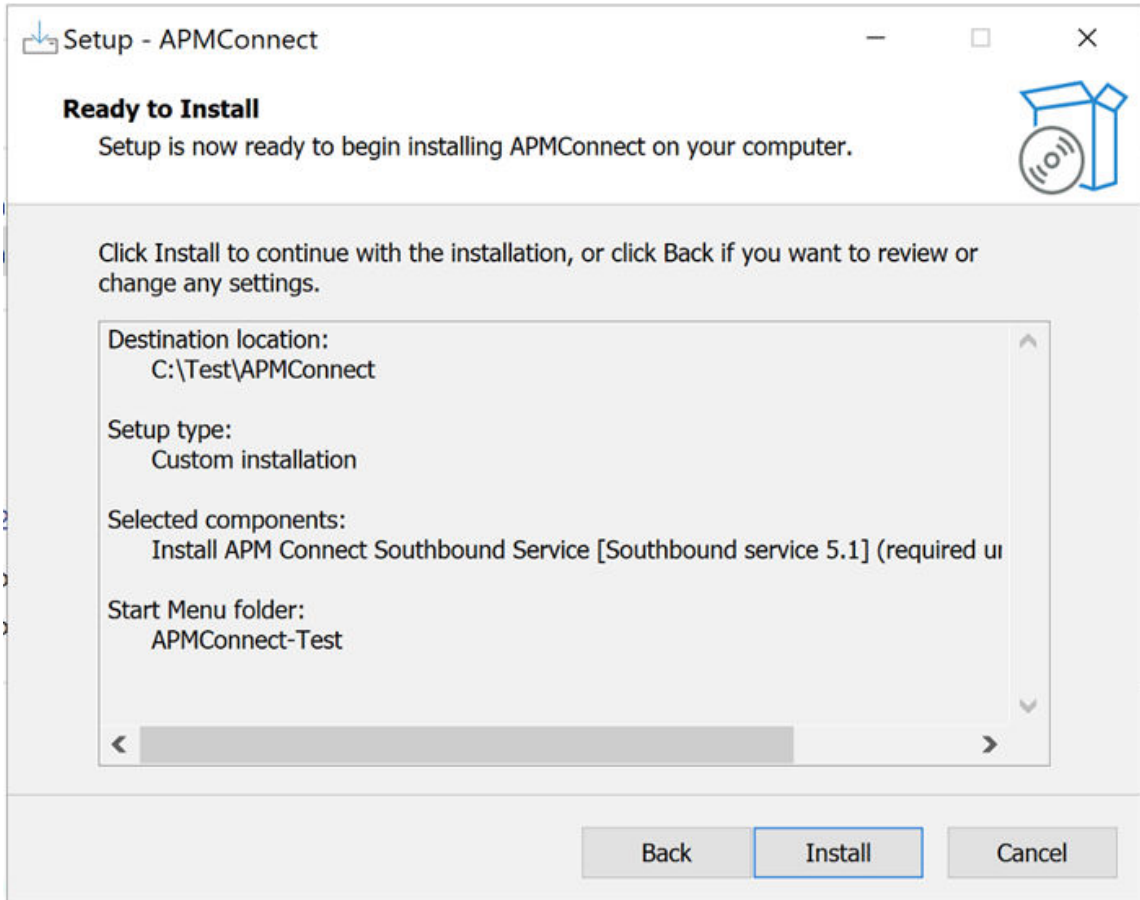

10. Review the installation settings and select **Install**.
The progress of the installation is displayed.

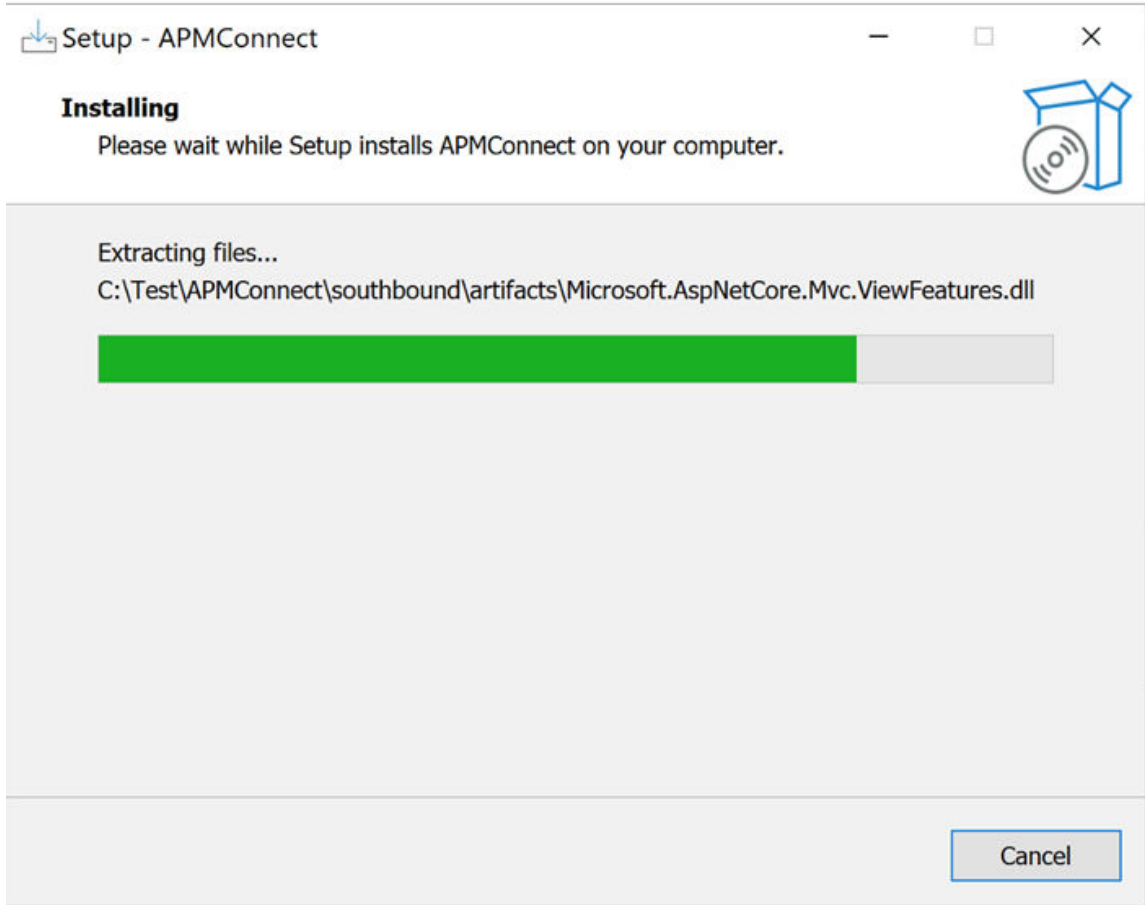

11. After the installation is complete, select **Yes, restart the computer now** and select **Finish** to restart the server.

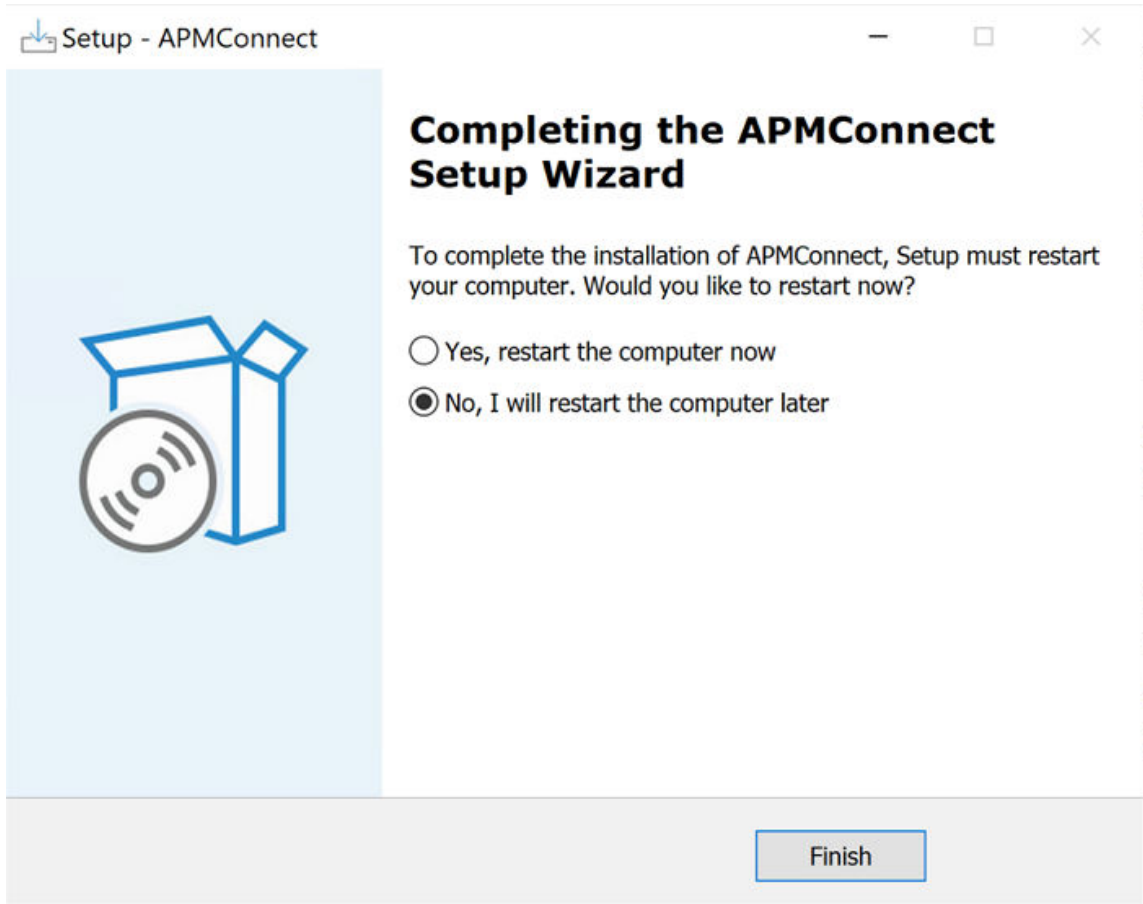

The APM Connect Southbound Service is installed. Open Services.msc and validate that **APM Connect Southbound Service** is available in the Services panel.

Next Steps

After installation, the Southbound Service will not be in the start state. Configure `appsettings.json` and then start the service manually.

Configure APMC Southbound Service

About This Task

You can configure the APM Connect Southbound Service using the `appsettings.json` configuration file available at the location, `C:\Program Files\APM.Connect.Southbound.`

Procedure

1. Access the `appsettings.json` file in an application that can be used to modify JSON files (for example, Notepad++).
2. Based on your requirement, set the following parameters:
 - Logging: Logging Level
 - FileWSDL: Contains the configuration for the EAM file receiver.
 - AppConfiguation section contains the following parameters:
 - IR staging Database information (ADL 4.6 APM, General Recommendation)

- IR_Host
- IR_Port
- IR_Database
- IR_Schema
- IR_UserId
- IR_Password
- ADL configuration
 - Default_Base_Directory - This is for the CSV file share for the DL between APM and the APMC Southbound Service.
 - Directory_Path - For the ADL root folder of the Scan and Archive.
 - Polling_Frequency_In_Milliseconds
 - Max_File_Size_In_Bytes
 - Max_Filename_Length
 - Valid_Extensions
 - Valid_Zip_Extensions
- APM (Application Server) configuration (ADL,V5 Audit JOB)
 - Apm_Api_Test_Path
 - Web_Api_Path
 - Datasourceld
 - Id. (user-id)
 - Password
- EAM Server Connection Type Configuration (GENERAL RECOMMENDATION,WORKORDER GENERATION)
 - Sap_Connection_Type (Application/Message)
 - Use_API_Key (True/false)
 - API_Key
- APM Application ActiveMQ Credentials - For the v5 Audit Job (Applicable only for OnPrem)
 - ActivemqName (Queue name were the Asset Ingestion Completion Messages are posted by the Ingestor)
 - ActivemqUri
 - ActivemqUsername
 - ActivemqPassword
- UAA configuration (Applicable only for cloud)
 - Uaa-Token_Url
 - Uaa_Username
 - Uaa_Password
 - Uaa_Client_Id
 - Uaa_Client_Secret
 - Use_OAuth
- Websocket Configuration (Application only for Cloud)
 - WebSocket_Api_Path. e.g., <wss://<external-host>/conduit/api/v1>
- Ingestor Configuration
 - Ingestor_Api_Path

Note: For SSL configuration, see [Enable SSL For Southbound Service](#).

3. Save and close the file.

Example

Southbound Service Configuration example file:

```
//Please remove stars and fill values as mentioned
{
  "Urls": "http://0.0.0.0:5013",
  "Logging": {
    "LogLevel": {
      "Default": "Trace",
      "Microsoft.AspNetCore": "Trace"
    }
  },
  "Microsoft.AspNetCore.HttpLogging.HttpLoggingMiddleware":
  "Information",
  "FileWSDL": {
    "UrlOverride": "",
    "VirtualPath": "",
    "WebServiceWSDLMapping": {
      "EamFileReceiver": {
        "UrlOverride": "EamFileReceiver",
        "WSDLFile": "EamFileReceiver.wsdl",
        "SchemaFolder": "Schemas",
        "WSDLFolder": "Schemas"
      }
    }
  },
  "AllowedHosts": "*",
  "AppConfiguration": {
    "IR_Host": "****POSTGRES SERVER HOST****",
    "IR_Port": "5432",
    "IR_Database": "**IR_POSTGRES_DB_NAME**",
    "IR_Schema": "public",
    "IR_UserId": "postgres",
    "IR_Password": "**IR_POSTGRES_DB_PASSWORD**",
    "Is_Linux": false,
    "Linux_Base_Path": "",
    "Default_Base_Directory": "C:\\\\APMConnect",
    "Apm_Api_Test_Path": "/meridium/api/internal/connect/connectionstatus/ÅpmcToApm",
    "Use_SSL": false,
    "StoreLocation": "",
    "StorePassword": "",
    "CmmsId": "*****CMMS-ID*****",
    "Sap_Connection_Type": "Application",
    "Use_API_Key": false,
    "API_Key": "",
    "DownStream_Request_Timeout_In_Minutes": 2,
    "Directory_Path": "****ADL Directory folder[Example:\\\\APMCONNECTVM4.meridium.com\\\\APMConnect\\\\ADL]****",
    "Web_Api_Path": "http://*****APM APPLICATION HOST NAME*****/meridium/api/v1",
    "Ingestor_Api_Path": "http://*****APM APPLICATION HOST NAME*****/meridium/connect/api/v1",
    "DatasourceId": "*****APM DATASOURCE*****",
    "Id": "bl",
    "Password": "",
    "Polling_Frequency_In_MilliSeconds": 0,
    "Max_File_Size_In_Bytes": 100000000,
  }
}
```

```

    "Max_Filename_Length": 100,
    "Valid_Extensions": "zip,xlsx",
    "Valid_Zip_Extensions": "csv"
    "Enable_G2DL_Ingestion": true
  },
  "QueueOptions": {
    "ActiveMqHost": "**APM ACTIVE MQ HOST**",
    "ActiveMqPort": 61616,
    "FailoverHosts": [],
    "Username": "admin",
    "Password": "admin",
    "UseSsl": false
  },
  "ASPNETCORE_URLS": "http://+:5013",
  "DOTNET_PRINT_TELEMETRY_MESSAGE": false,
  "ASPNETCORE_ENVIRONMENT": "Production"
}

```

Customize Southbound Service

Southbound Service supports additional customization for custom RFC and custom field mapping (from APM to SAP) through template-based configuration.

1. Notification Create/Update/Close
2. Notification user status update
3. Work Order Creation

Custom Templates can be used for:

- Map additional APM fields to APM connect baseline RFC parameters.
- Trigger custom RFC for below interfaces/endpoints mentioned in table.

The baseline template is available in <southbound Installation folder>
 \SouthboundService\Templates\sap and sap-pi.

Table 1: Default Templates

EAM System	Template	Description	Interface
SAP	createnotification.xslt	Create SAP notification from APM recommendations. Configure/refer XSLT sheet to validate/configure APM fields to SAP RFC parameters.	Recommendations
SAP	Createnotification_response.xslt	Create notification response from SAP. Configure/refer XSLT sheet to validate/configure SAP RFC response values to APM response load.	Recommendations
SAP	Updatenotification.xslt	Update SAP notification from APM recommendations. Configure/refer XSLT sheet to validate/configure APM fields mapping to SAP RFC parameters.	Recommendations
SAP	Updatenotification_response.xslt	Update notification response from SAP. Configure/refer XSLT sheet to map custom fields from SAP RFC response to APM response.	Recommendations

EAM System	Template	Description	Interface
SAP	Updatenotification_userstatus.xslt	Update notification user status from APM to SAP. Configure XSLT sheet for additional fields mapping from APM to SAP RFC.	Recommendations
SAP	Updatenotification_userstatus_response.xslt	Response from SAP for update notification user status RFC call. Configure XSLT sheet to map additional/custom fields from RFC to APM response.	Recommendations
SAP	Closenotification.xslt	Close the SAP notification APM to SAP. Configure XSLT sheet for calling custom RFC or mapping additional/custom fields in SAP.	Recommendations
SAP	Closenotification_response.xslt	Response from SAP for close notification RFC call.	Recommendations
SAP	Createworkorder.xslt	Create SAP work order call for inspection and calibration tasks. Configure XSLT sheet for custom or additional fields mapping to SAP RFC parameters.	Work management interface
SAP	Createworkorder_response.xslt	Response from SAP for create work order RFC call. Configure for additional or custom fields mapping from SAP response to APM response.	Work management interface
SAP	Createworkorder_notification.xslt	Create SAP notification for inspection and calibration tasks instead of work order. Configure XSLT sheet for custom RFC or additional fields map from APM to SAP.	Work management interface
SAP	Createworkorder_notification_response.xslt	SAP response for create notification RFC call for inspection and calibration tasks. Configure for additional or custom fields map from SAP RFC response to APM response.	Work management interface
SAP	Functions.xslt	Used for APM connect xslt transformation.	APM Connect internal use.

Table 2: Supported Parameters

Name	Parameter Type	Sample Config
Single value	Import & Export	<pre data-bbox="1062 321 1401 569"> <PARAMETER> <NAME>NOTIF_TYPE</ NAME> <VALUE><xsl:value- of select='Fields/ MI_REC_NOTIF_TYPE_C' / > </VALUE> </PARAMETER> </pre>
Structure	Import & export	<pre data-bbox="1062 642 1401 1167"> <PARAMETER> <NAME>NOTIFHEADER</ NAME> <VALUE> <LINE> <COLUMN> <NAME>EQUIPMENT</ NAME> <VALUE> <xsl:value-of select='EquipmentID' / > </VALUE> </COLUMN> </LINE> </VALUE> </PARAMETER> </pre>

Name	Parameter Type	Sample Config
Table	Table	<pre> <PARAMETER> <NAME>NOTIFITEM</ NAME> <VALUE> <xsl:for-each select='NotificationI tems'> <LINE> <COLUMN> <NAME>ITEM_KEY</NAME> <VALUE> <xsl:value-of select='Item_Key'>/> </ VALUE> </ COLUMN> <COLUMN> <NAME>ITEM_SORT_NO</ NAME> <VALUE> <xsl:value-of select='Item_SortNumb er'>/> </ VALUE> </ COLUMN> <COLUMN> </ LINE> </ xsl:for-each> </ VALUE> </ PARAMETER> </pre>

Note: The RAW Data Type is not supported.

Map additional APM fields to baseline SAP RFC's

Requirement: Map additional below two fields from APM recommendation to SAP notification creation RFC.

- CC_REC_CODIN_GROUP_CHR (Coding Group)

1. Navigate to <southbound installation folder>\southbound \SouthboundService\Templates\SAP or SAP-PI).
2. Access the createnotification.xslt file in an application that can be used to modify XSLT files (for example, Notepad++).
3. Search for SAP input parameter name defined in RFC (“NOTIFHEADER”) and add the following additional XML tag to map values from APM recommendation fields.

```

<xsl:import href="functions.xslt"/>
<xsl:template match='/Recommendation'>
  <Recommendation>
    <ACTION>
      <TYPE>RFC</TYPE>
      <NAME>/MIAPM/CREATE_NOTIF</NAME>
      <PARAMETERS>
        <PARAMETER>
          <xsl:if test="Fields/MI_REC_WK_REQ_REF_CHR != ''">
            <PARAMETER>
              <NAME>NOTIFHEADER</NAME>
              <VALUE>
                <LINE>
                  <!-- APM Custom fields mapping start -->
                  <COLUMN>
                    <NAME>CODE_GROUP</NAME>
                    <VALUE>
                      <xsl:value-of select=
                        'Fields/CC_REC_CODIN_GROUP_CHR
                      '/>
                    </VALUE>
                  </COLUMN>
                </VALUE>
              </PARAMETER>
            </xsl:if>
          </PARAMETERS>
        </ACTION>
      </Recommendation>
    <!-- APM Custom fields mapping END -->
  </xsl:template>

```

Custom RFC call

Requirement: APM connect Southbound Service provide the capability to call custom SAP RFC's. Call custom SAP RFC (ZMIAPM_CREATE_NOTIF) to create SAP notification.

1. Navigate to <southbound installation folder>\southbound \SouthboundService.
2. Access the appsettings.json file in an application that can be used to modify JSON files (for example, Notepad++).
3. Search for "Generalisable" and set the value as true:

```
"EnableGenericRfc" : true
```
4. Navigate to <southbound installation folder>\southbound \SouthboundService\Templates\SAP or SAP-PI.
5. Access the createnotification.xslt file in an application that can be used to modify XSLT files (for example, Notepad++).
6. Search for "<NAME>/MIAPM/CREATE_NOTIF</NAME>" and replace the baseline SAP RFC name with custom RFC name as follows:

```
<NAME >ZMIAPM_CREATE_NOTIF </NAME>
```

Note: Ensure that you update all the RFC parameters names and columns correctly if they are different than baseline APM connect RFC. That is, update the import parameters with “Z_NOTIFHEADER” instead of “NOTIFHEADER”.

```
<?xml version="1.0" encoding="utf-8"?>
<xsl:stylesheet version="1.0" xmlns:xsl=
"http://www.w3.org/1999/XSL/Transform">
  <xsl:import href="functions.xslt"/>
  <xsl:template match='/Recommendation'>
    <Recommendation>
      <ACTION>
        <TYPE>RFC</TYPE>
        <NAME>ZMIAPM_CREATE_NOTIF </NAME>
        <PARAMETERS>
          <PARAMETER>
            <xsl:if test="Fields/MI_REC_WK_REQ_REF_CHR != ''">
              <PARAMETER>
                <PARAMETER>
                  <NAME>Z_NOTIFHEADER</NAME>
                  <VALUE>
                    <LINE>
                      <COLUMN>
                        <NAME>Z_CODE_GROUP</NAME>
                        <VALUE>
                          <xsl:value-of select=
'Fields/CC_REC_CODIN_GROUP_CHR
' />
                        </VALUE>
                      </COLUMN>
```

7. Save the template.

Uninstall Southbound Service

Procedure

1. Open the APMConnect - Uninstaller application.
2. Select **Remove APM Connect Southbound Service** checkbox and select **Uninstall**.
3. Open `services.msc` and verify that the service is removed from the Windows Service Panel.

Enable SSL For Southbound Service

About This Task

The following procedure outlines the necessary configurations to enable SSL for the Southbound Service, based on Microsoft documentation.

Procedure

1. Access the `appsettings.json` file in an application that can be used to modify JSON files (for example, Notepad++).

2. Insert the following JSON block at the top of the settings under the root in the `appsettings.json` file:

SSL Configuration

```
"Kestrel": {
  "Endpoints": {
    "HttpsDefaultCert": {
      "Url": "https://test.domain.com:5013"
    }
  },
  "Certificates": {
    "Default": {
      "Path": "C:\\temp\\meridium_SAN_04212024.pfx",
      "Password": "K2p8HBxb"
    }
  }
},
```

3. Modify the `ASPNETCORE_URLS` property to utilize HTTPS. Ensure that the property is set to use HTTPS on port 5013:

```
"ASPNETCORE_URLS": "https://+:5013"
```

4. Restart the service to apply the configuration changes.
5. Enable SSL for downstream service
 - a) To enable SSL in Southbound Service for downstream interactions (SAP, Maximo etc.), update the below configuration properties in `appsettings.json` file, under the `AppConfiguration` section:

Note: When interacting securely with APM and EAM systems, it is essential to combine both servers' certificates into a single pfx file.

SSL for Down Stream service interaction:

```
"Use_SSL": true,
"StoreLocation": "C:\\Certs\\TestSSL\\FileName.pfx", //File
should be in PFX format only.
"StorePassword": "xyz", // Encrypted password is also
supported. Use only the crypto utility tool in southbound service
to encrypt the password.
```

- b) Restart the service again to ensure that the changes take effect.

Log Archive Configuration

About This Task

This procedure outlines the steps to update the log configuration for the Southbound Service using NLog as the logging framework.

Procedure

1. Locate and navigate to the **bin** folder of the Southbound Service.
2. Open the file `nlog.config` file.
3. Add the following properties in the `target xsi:type="File"` section of the `nlog.config` file, to enable archival and deletion of logs:

- a. `archiveFileName`: Specify the location and name of the archived file.
- b. `archiveEvery`: Define a time interval for the archival of logs.
- c. `maxArchiveDays`: Set the number of days the file will remain archived before deletion.
- d. `archiveNumbering`: Define the format of the archive file name, replacing `{#}` in `archiveFileName`.
- e. `archiveAboveSize`: Set the threshold value (in bytes) for log file size, triggering the generation of a new log file.

Configuration Sample:

```
<target xsi:type="File" name="allfile" fileName="c:\ProgramData
\Meridium\Logs\APM.Connect.Southbound_{$shortdate}.log"
  layout="{$longdate}|{$uppercase:{$level}}|{$
{mdlc:item=TenantId:whenEmpty=na}|{$logger}|{$message} {$exception}"
  archiveFileName="c:\ProgramData\Meridium\Logs
\APM.Connect.Southbound_{$shortdate}.{$#}.log"
  archiveEvery="Day" maxArchiveDays="30"
  archiveNumbering="DateAndSequence" archiveAboveSize="2000000"/>
```

APM Connection String Configuration

About This Task

This procedure outlines the steps required to update the connection string in the APM system to redirect Southbound requests to the NextGen ETL Service.

Procedure

1. Navigate to **Admin > Operation Manager > Connections**.
2. Select **APM Connect** option.
3. Under **General** settings, locate the connection string that requires modification.
4. Update the connection string to following format: `http://<APMC Southbound Service installation server>:<APMC Southbound Service installation port>`

Configuration for Customizations

Overview

APM Connect supports customizations through different configuration options. These customizations can be achieved through control and configuration tables in IRDB for extractions and templates for the Southbound interfaces.

Note: These configurations are not mandatory if the interfaces need to be executed with baseline configuration.

Create the Intermediate Repository Database

This topic describes how to set up a repository in preparation to run your first job.

Before You Begin

Important: If you are using both the Data Loaders and an EAM Adapter, you need only one Intermediate Repository Database.

- Before you can prepare and deploy the repository, you must import the CreateIntermediateRepository job.
- If you are using the Data Loaders and the EAM Adapters, you must deploy and run the CreateIntermediateRepository job for each set of adapters.
- For SAP adapters, you must first run the Static Data job.
- For multiple EAM systems, the context file parameter values for a specific type of system must be identical except for the value of CMMS_ID.
- For multiple EAM systems, the Intermediate Repository Connection parameters have the same values for all adapters connected to this APM system.

Important: Each time you run the CreateIntermediateRepository you recreate the APM database to the baseline settings, removing any previous configuration. When you run the addSourceSystem job, the job will add new source systems based on the CMMS_ID and the SOURCE_SYSTEM_TYPE. If the job is run an additional time with the same configuration, it will reset the control values of an existing source system.

Procedure

1. Log in to the APM Connect Administration Center web application.

Note: The user logging in must have access to the Job Conductor by being designated the Operations Manager role. By default, users designated as administrators do not have Job Conductor permissions.

2. In the **Job Conductor** workspace, in the appropriate project, select the CreateIntermediateRepository job.

Note: For ServiceMax, this job is called CreateIntermediateRepository_ServiceMax.

3. Select **Context parameters**.

The **Context parameters** section appears.

4. Configure the following parameter.

Context Parameter	Description
CONFIG_FILE_PATH	<p>The file path to context files for the jobs.</p> <p>Important:</p> <ul style="list-style-type: none"> • You must change the default value to reflect the actual path to your configuration file. • CMMS_ID and SOURCE_SYSTEM_TYPE must be set in the context file.

5. Select **Run**.

If you are configuring a single system, you have completed your configuration.

The intermediate repository database is created for the project.

If you are configuring multiple EAM systems, perform the remaining steps in this topic.

6. In the **Job Conductor** workspace, in the appropriate project, select the addSourceSystem job.

7. Configure the following parameter.

Context Parameter	Description
CONFIG_FILE_PATH	<p>The file path to context files for the jobs.</p> <p>Important:</p> <ul style="list-style-type: none"> You must change the default value to reflect the actual path to your configuration file. CMMS_ID and SOURCE_SYSTEM_TYPE must be set in the context file.

8. Select **Run**.

9. Repeat steps 6 on page 39 through 8 on page 40 for all adapters.

autoextractor_control Table

The purpose of the auto extractor control table is to specify the conditions and data extracted by the APM Connect interfaces. The structure of the table is outlined below, indicating the fields that must be updated during customization.

Field Name	Description	Configurable
autoextract_id	Auto-generated index	Do Not Modify
batch_name	Interface Batch Name	Do Not Modify
active	<ul style="list-style-type: none"> Inactive and will not run Active and will run 	Yes
job_name	APM Connect sub-process name	Do Not Modify
filename	Filename returned by SAP	Do Not Modify
run_in_background	<p>True - Run in SAP background</p> <p>False - Run in foreground</p>	Yes
default_date_value	Date used when SAP returns a null date	Do Not Modify
field_separator	Indicates file delimiter in the file returned by SAP	Do Not Modify
abap_cursor_fetch_size	Invokes SAP to read large data sets as a batch of the size indicated	Do Not Modify
extract_schema_definition	<p>An array utilized in SAP select statements when retrieving data</p> <p>Structure: "SAP Table Name SAP Field Name"</p> <p>Delimiter: ";"</p>	Yes
join_condition	Join condition used when querying the data in SAP	Yes
where_condition	Where condition used when querying the data in SAP	Yes
for_all_entries_field_name	Field name used in SAP where a "For All Entries" statement is in use in the SAP Query	Do Not Modify
for_all_entries_field_type	SAP Field data type used in SAP where a "For All Entries" statement is in use in the SAP Query	Do Not Modify
for_all_entries_condition	Condition used in SAP where a "For All Entries" statement is in use in the SAP Query	Do Not Modify
object_list_type	Object to create a list of objects when utilizing the object_list_control table	Do Not Modify

Field Name	Description	Configurable
object_type	Refers to SAP object, interface name, and SAP Table name when utilizing the object_list_control table	Do Not Modify
sap_background_job_name	When running in SAP background, this is the job name passed to SAP.	Yes
step_seq	Not in use	Do Not Modify
cmms_id	SAP System ID	Yes

autoloader_control Table

The purpose of the auto loader control table is to specify the condition under which the data extracted in active entries in the autoextractor_control is staged in temporary tables in the IRDB. The structure of the table is outlined below, indicating the fields that must be updated during customization.

Field Name	Description	Configurable
autoloader_id	Auto-generated index	Do Not Modify
batch_name	Interface Batch Name	Do Not Modify
active	<ol style="list-style-type: none"> Inactive and will not run Active and will run <p>Note: You need to match active status for the same batch_name in autoextracor_control table</p>	Yes
job_name	APM Connect sub-process name	Do Not Modify
filename	Filename returned by SAP that will load into IRDB temporary table	Do Not Modify
table_name	IRDB temporary Table Name	Do Not Modify
null_string	Default Date String	Do Not Modify
field_separator	Indicates file delimiter in the file returned by SAP	Do Not Modify
row_separator	Indicates new line indicator in the file returned by SAP	Do Not Modify
delete_where_clause	Utilized in multiple EAM system configurations to clear entries in temporary table for the EAM system that is being updated	Do Not Modify
object_type	Refers to SAP object, interface name, and SAP Table name when utilizing the object_list_control table	Do Not Modify
transform_job_name	APM Connect transformation sub-process name	Do Not Modify
cmms_id	SAP System ID	Yes

autojoin_control Table

The purpose of the auto join control table is to fetch the data loaded into the IRDB temporary tables and create the data payloads to be loaded into APM. The structure of the table is outlined below indicating the fields that should be updated during customization.

Field Name	Description	Configurable
autojoin_id	Auto-generated index	Do Not Modify
batch_name	Interface Name	Do Not Modify
table_name	The data table name to identify the data sheet when loading into APM.	Do Not Modify
sql_execution_order	Specifies the order of the data load for each batch_name	Do Not Modify
sql	The query to extract data from the temporary table in the IRDB.	Yes
site_reference	Site reference in APM can be an APM Family Field or a constant	Yes
apm_site_reference_column	Field name for Site Reference in APM	Do Not Modify
apm_site_reference_family	APM Family to fetch the site reference in which site_reference field resides.	Do Not Modify
use_relationship_lookup	Null – ignored 1. Do not use relationships 2. Use relationships	Do Not Modify
default_site_reference	Default Site is no site is configured	Yes
primary_family_id	APM Family ID	Do Not Modify
cmms_id	SAP System ID	Yes

southbound_mapping_control Table

The purpose of this table is to provide a dynamic mapping capability from APM fields (including custom fields) in the Recommendation to SAP fields supported by the baseline interface for notification creation. The request from APM has the following details:

- Entity (EQ/FL) on which the request is being generated
- Connection information of the EAM system
- APM Family Fields (including custom fields) from the Recommendation

The structure of the table is outlined below, indicating the fields that must be updated during customization.

Field Name	Description	Configurable
southbound_mapping_control_id	Auto-generated index	Do Not Modify
apm_field_name	APM Field Name	Yes
target_field_name	SAP Field Name	Do Not Modify
target_field_map_name	SAP RFC Parameter Name	Do Not Modify
mapping_enabled	True – Will be pushed to SAP False – Will not be pushed to SAP	Yes
target_default_value	Default value in case data is not provided in the payload	Yes
cmms_id	SAP System ID	Yes

Configure Intermediate Repository Database

You can configure APM Connect to:

- Extract data from your EAM system
- Push APM data back into your EAM system

To enable these configurations, you can modify the table entries in the Intermediate Repository Database (IRDB).



Caution: Before editing the IRDB table entries, we recommend that you create a backup of the existing database. This ensures that you restore the database to the original state if required.

Create a Database Backup

Procedure

1. Select the **Start** button on Windows, right-click **Command Prompt**, and then select **Run as administrator**.
The **Command Prompt** window appears.
2. At the command prompt, enter the following command:

```
pg_dump -U postgres -Fc database_name > database.dump
```

where,

- `database_name` is the name of the database for which you want to create a backup.
- `database.dump` is the custom. Additionally, `database.dump` can be renamed to any name with a `.dump` extension.

Note: If you receive the “`pg_dump`” is not recognized as an internal or external command error message while executing the database backup command, run the command again using full path of the Postgres installation. For example, `C:\Program Files\PostgreSQL\11\bin\pg_dump” U postgres -Fc database_name > database.dump`

Restore Database From a Backup File

Procedure

1. Select the **Start** button on Windows, right-click **Command Prompt**, and then select **Run as administrator**.
The **Command Prompt** window appears.
2. At the command prompt, the following command:

```
pg_restore -U postgres -d database_name database.sql
```

In the command, replace `postgres` with a username with full access to the database labeled `database_name`. Additionally, `database.sql` can be renamed to any name with a `.sql` extension.

Note: If you receive the “`pg_dump`” is not recognized as an internal or external command error message while executing the database restore command, run the command again using full path of the Postgres installation. For example, `C:\Program`

```
Files\PostgreSQL\11\bin\ pg_restore" -U postgres -d database_name
database.dump
```

Configure Northbound and Southbound Data Extraction SAP Mapping

To facilitate a dynamic mapping capability for data extracted from SAP and pushed into APM, the below IRDB tables can be configured.

- autoextractor_control
- autoloader_control
- autojoin_control
- southbound_mapping_control

The structure of the tables and fields that are modified during configuration is outlined in subsequent sections of the documentation. Within each table are rows that correspond with steps for data extraction to support the following data types:

- Asset Strategy Integration
- Equipment
- Equipment Technical Characteristics
- Functional Location
- Functional Location Technical Characteristics
- Planned Work Interface
- Static Data
- Work Management Interface
- Work History

Northbound Data Integration Data Flows

During the northbound data integration, each interface follows the following logic:

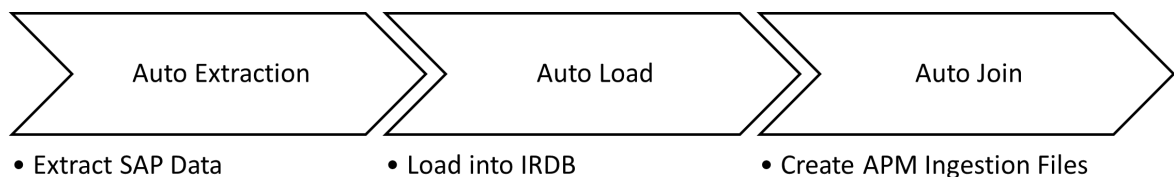

Southbound Data Integration Data Flows

During the southbound data integration, each interface follows the following logic:

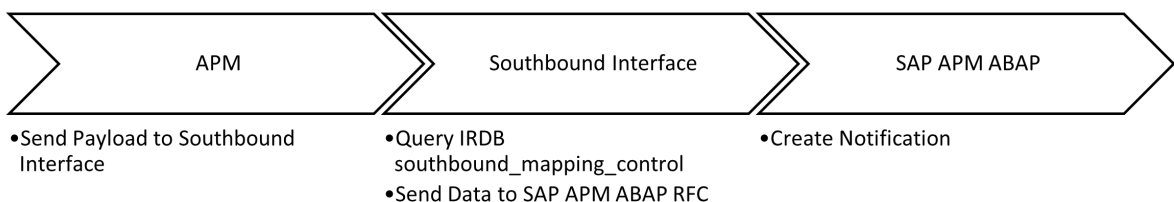

Configure Source System Custom Field Mappings or Default Values

APM Connect documents a baseline set of fields that are considered standard in the APM to SAP Notification Creation integration with SAP. Additionally, there is capability to configure

these and other fields to be included in the Notification Creation process. For information on the available fields to add to mapping, refer to the List of attributes that can be added to Notification Creation from APM to SAP topic. This topic describes how to configure additional baseline fields or make changes to default values.

Before You Begin

To successfully perform this task, you must have the following:

- Administrative rights to the APM Connect database from which you are retrieving the field values or setting the default values.
- A database tool, such as DBeaver or DBVisualizer.

About This Task

There are times when you need to have information that is stored in APM displayed in your source system database. To achieve this goal, you need to modify tables used by APM to send data to your source system.

Note: If Custom field mappings are needed, or fields that are not in this list, customization options exist with our Integration Center of Excellence engagement process.

The following procedure describes how to either configure a mapping between APM and your source system or to set a default in your source system from APM.

The following image is an example of the southbound_mapping_control table as displayed by a database tool.

southbound_mapping_control_id	apm_field_name	target_field_name	target_field_map_name	mapping_value
1	MI_REC_NOTIF_TYPE_C	NOTIF_TYPE	NOTIF_TYPE	true
2		TASK_DETERMINATION	TASK_DETERMINATION	false
3		SENDER	SENDER	false
4		ORDER_ID	ORDER_ID	false
5		REFOBJECTTYPE	REFOBJECTTYPE_NOTIFHEADER	false
6		REFOBJECTKEY	REFOBJECTKEY_NOTIFHEADER	false
7		REFRELTTYPE	EQUIPMENT_NOTIFHEADER	false
8	EquipmentID	EQUIPMENT	EQUIPMENT_NOTIFHEADER	true
9	LocationID	FUNCT_LOC	FUNCT_LOC_NOTIFHEADER	true
10		ASSEMBLY	ASSEMBLY_NOTIFHEADER	false
11		SERIALNO	SERIALNO_NOTIFHEADER	false
12		MATERIAL	MATERIAL_NOTIFHEADER	false
13		DIVISION	DIVISION_NOTIFHEADER	false
14		SALES_ORG	SALES_ORG_NOTIFHEADER	false
15		DISTR_CHAN	DISTR_CHAN_NOTIFHEADER	false
16		SALES_OFFICE	SALES_OFFICE_NOTIFHEADER	false
17		SALES_GRP	SALES_GRP_NOTIFHEADER	false
18	MI_REC_SHORT_DESCR_CHR	SHORT_TEXT	SHORT_TEXT_NOTIFHEADER	true
19	MI_REC_PRIORITY_C	PRIORITY	PRIORITY_NOTIFHEADER	true
20		DESSTDATE	DESSTDATE_NOTIFHEADER	false
21		DESSTIME	DESSTIME_NOTIFHEADER	false
22		DESENDDATE	DESENDDATE_NOTIFHEADER	false
23		DESENDTM	DESENDTM_NOTIFHEADER	false
24		DEVICEDATA	DEVICEDATA_NOTIFHEADER	false
25		PM_WKCTR	PM_WKCTR_NOTIFHEADER	false
26		PURCH_NO_C	PURCH_NO_C_NOTIFHEADER	false
27		PURCH_DATE	PURCH_DATE_NOTIFHEADER	false
28		PLANPLANT	PLANPLANT_NOTIFHEADER	false

Note: This feature is not available for creating work orders.

Procedure

1. Using a database tool, navigate to the APM database you want to configure.
2. In the database navigation, in the Tables folder, select **southbound_mapping_control**.
3. Navigate to the **target_field_name** and **target_field_map_name** column you want to configure.
4. Configure the field mapping or default value for your source system.

Item to configure	How to configure																												
Field mapping	<p>In the apm_field_name column, enter the name of the APM field that contains the value to apply in the source system, and then set the value in the mapping_enabled column to <code>true</code></p> <p>For example, if you want to set the source system value of REPORTEDBY in map table REPORTEDBY_NOTIFHEADER from the APM field CurrentUserID, the table would resemble the following when you complete your update.</p> <table border="1"> <thead> <tr> <th>southbound_mapping_control_id</th> <th>apm_field_name</th> <th>target_field_name</th> <th>target_field_map_name</th> <th>mapping_enabled</th> <th>target_default_value</th> <th>cmms_id</th> </tr> </thead> <tbody> <tr> <td>31</td> <td></td> <td>STRMLFNDATE</td> <td>STRMLFNDATE_NOTIFHEADER</td> <td>false</td> <td></td> <td>PRF-800</td> </tr> <tr> <td>32</td> <td></td> <td>STRMLFNTIME</td> <td>STRMLFNTIME_NOTIFHEADER</td> <td>false</td> <td></td> <td>PRF-800</td> </tr> <tr> <td>33</td> <td>CurrentUserID</td> <td>REPORTEDBY</td> <td>REPORTEDBY_NOTIFHEADER</td> <td>true</td> <td></td> <td>PRF-800</td> </tr> </tbody> </table> <p>Important: If, after configuring the mapping, you see a blank value for the field, make sure the value you entered in the apm_field_name column is correct.</p>	southbound_mapping_control_id	apm_field_name	target_field_name	target_field_map_name	mapping_enabled	target_default_value	cmms_id	31		STRMLFNDATE	STRMLFNDATE_NOTIFHEADER	false		PRF-800	32		STRMLFNTIME	STRMLFNTIME_NOTIFHEADER	false		PRF-800	33	CurrentUserID	REPORTEDBY	REPORTEDBY_NOTIFHEADER	true		PRF-800
southbound_mapping_control_id	apm_field_name	target_field_name	target_field_map_name	mapping_enabled	target_default_value	cmms_id																							
31		STRMLFNDATE	STRMLFNDATE_NOTIFHEADER	false		PRF-800																							
32		STRMLFNTIME	STRMLFNTIME_NOTIFHEADER	false		PRF-800																							
33	CurrentUserID	REPORTEDBY	REPORTEDBY_NOTIFHEADER	true		PRF-800																							
Default value	In the target_field_default column, enter the value you want to be the default in your source system and set the value in the mapping_enabled column to <code>false</code> .																												

Results

Your source system mappings or default values are configured.

IRDB Configuration Examples

Functional Location

About This Task

An end user is recommended to have a custom field in SAP extracted and added to a custom field in APM. Details on SAP and APM families are as follows:

- SAP Table Name: IFLOT
- SAP Field Name: ERNAM
- APM Family Name: MI_FLOC00
- APM Field Name: CC_CREATED_BY

To update the interface, the following steps need to be followed:

Procedure

1. Update the autoextractor_control table
 - a. Schema definition needs to be added to the extract_schema_definition field for batch name "Functional_Location_Step_1". This can be done by appending "IFLOT|ERNAM" to the end of the extract_schema_definition.
2. Update the autoloader_control table
 - a. Duplicate the row for batch_name="Functional_Location_Step_1"
 - b. In the new row, update:
 - i. table_name to a unique value (CUSTOM_FLOC)
 - ii. jobname to IR_Custom_Loader
3. Update the autojoin_control table

- a. To update the sql field in the row where batch_name="Functional_Location" and table_name="MI_FNLOC00":
 - i. Select the new field (IFLOT|ERNAM as CC_CREATED_BY)
 - ii. Add a left autojoin to include the custom table included in step 2, i.e., left outer join "CUSTOM_FLOC" on "IFLOT|TPLNR." =" MI_FNCLOC00_FNC_LOC_C"

Equipment

About This Task

An end user is recommended to have a custom field in SAP extracted and added to a custom field in APM. Details on SAP and APM families are as follows:

- SAP Table Name: EQUI
- SAP Field Name: ERNAM
- APM Family Name: MI_EQUIP000
- APM Field Name: CC_CREATED_BY

To update the interface, the following steps need to be followed:

Procedure

1. Update the autoextractor_control table
 - a. Schema definition needs to be added to the extract_schema_definition field for batch name "Equipment_Step_1". This can be done by appending "EQUI|ERNAM" to the end of the extract_schema_definition.
2. Update the autoloader_control table
 - a. Duplicate the row for batch_name="Equipment_Step_1"
 - b. In the new row, update:
 - i. table_name to a unique value (CUSTOM_EQUI)
 - ii. jobname to IR_Custom Loader
3. Update the autojoin_control table
 - a. To update the sql field in the row where batch_name="Equipment" and table_name="MI_EQUIP000":
 - i. Select the new field (EQUI|ERNAM as CC_CREATED_BY)
 - ii. Add a left autojoin to include the custom table included in step 2, i.e., left outer join "CUSTOM_EQUI" on "EQUI|EQUNR." =" MI_EQUIP000_EQUIP_ID_C"

Work History

About This Task

An end user is recommended to have a custom field in SAP extracted and added to a custom field in APM. Details on SAP and APM families are as follows:

- SAP Table Name: VIQMEL
- SAP Field Name: ERNAM
- APM Family Name: MI_EVWKHIST
- APM Field Name: CC_CREATED_BY

To update the interface, the following steps need to be followed:

Procedure

1. Update the autoextractor_control table
 - a. Schema definition needs to be added to the extract_schema_definition field for batch name "WORKHISTORY_STEP_1". This can be done by appending "VIQMEL|ERNAM" to the end of the extract_schema_definition.
2. Update the autoloader_control table
 - a. Duplicate the row for batch_name=" WORKHISTORY_STEP_1"
 - b. In the new row, update:
 - i. table_name to a unique value (CUSTOM_WH)
 - ii. jobname to IR_Custom Loader
3. Update the autojoin_control table
 - a. To update the sql field in the row where batch_name=" WORKHISTORY" and table_name="WorkHistory":
 - i. Select the new field (VIQMEL|ERNAM as CC_CREATED_BY)
 - ii. Add a left autojoin to include the custom table included in step 2, i.e., left outer join "CUSTOM_WH" on "VIQMEL|QMNAM." =" MI_EVWKHIST_RQST_ID_C"

Work Management Interface

An end user is recommended to have a custom field in SAP extracted and added to a custom field in APM. Details on SAP and APM families are as follows:

- SAP Table Name: VIMPLA
- SAP Field Name: ERNAM
- APM Family Name: MI_TASKINSP
- APM Field Name: CC_CREATED_BY

Inspection Task

About This Task

To update the interface, the following steps need to be followed for inspection tasks:

Procedure

1. Update the autoextractor_control table
 - a. Schema definition needs to be added to the extract_schema_definition field for batch name "WMI_STEP_2". This can be done by appending "VIMPLA L|ERNAM" to the end of the extract_schema_definition.
2. Update the autoloader_control table
 - a. Duplicate the row for batch_name=" WMI_STEP_2"
 - b. In the new row, update:
 - i. table_name to a unique value (CUSTOM_WMI_INSP)
 - ii. jobname to IR_Custom Loader
3. Update the autojoin_control table
 - a. To update the sql field in the row where batch_name="WMI" and table_name="EQUIP_INSPECTION_TASK":

- i. Select the new field (VIMPLA |ERNAM as CC_CREATED_BY)
- ii. Add a left autojoin to include the custom table included in step 2, i.e., left outer join "CUSTOM_WMI_INSP" on "VIMPLA|WARPL." =" MI_TASK_MAINT_PLAN_NBR_C"
- b. To update the sql field in the row where batch_name="WMI" and table_name=" FLOC_INSPECTION_TASK"
 - i. Select the new field (VIMPLA |ERNAM as CC_CREATED_BY)
 - ii. Add a left autojoin to include the custom table included in step 2, i.e., left outer join "CUSTOM_WMI_INSP" on "VIMPLA|WARPL." =" MI_TASK_MAINT_PLAN_NBR_C"

Calibration Task

About This Task

To update the interface, the following steps need to be followed for calibration tasks:

Procedure

1. Update the autoextractor_control table
 - a. Schema definition needs to be added to the extract_schema_definition field for batch name "WMI_STEP_3". This can be done by appending "VIMPLA L|ERNAM" to the end of the extract_schema_definition.
2. Update the autoloader_control table
 - a. Duplicate the row for batch_name=" WMI_STEP_3"
 - b. In the new row, update:
 - i. table_name to a unique value (CUSTOM_WMI_CAL)
 - ii. jobname to IR_Custom Loader
3. Update the autojoin_control table
 - a. To update the sql field in the row where batch_name="WMI" and table_name=" EQUIP_CALIBRATION_TASK":
 - i. Select the new field (VIMPLA |ERNAM as CC_CREATED_BY)
 - ii. Add a left autojoin to include the custom table included in step 2, i.e., left outer join "CUSTOM_WMI_CAL" on "VIMPLA|WARPL." =" MI_TASK_MAINT_PLAN_NBR_C"
 - b. To update the sql field in the row where batch_name="WMI" and table_name=" FLOC_CALIBRATION_TASK":
 - i. Select the new field (VIMPLA |ERNAM as CC_CREATED_BY)
 - ii. Add a left autojoin to include the custom table included in step 2, i.e., left outer join "CUSTOM_WMI_CAL" on "VIMPLA|WARPL." =" MI_TASK_MAINT_PLAN_NBR_C"

Notifications

About This Task

You must create a custom field extracted from APM into the SAP Coding Code. Details on SAP and APM families are outlined below:

- APM Field Name: MI_REC_CODING
- SAP Target Field Name: CODING

To perform updates:

Procedure

1. Access the southbound_mapping_control table.
2. Modify the apm_family_name field to MI_REC_CODING where target_field_name is CODING.
3. Set the mapping_enabled Boolean to True.

Automated Data Loader Service Installation

Install Automated Data Loader Service

The Automated Data Loader service required for integrating to APM using Automatic Data Loader (ADL) is configured as part of the Southbound Service installation. To use only the ADL, execute the Southbound Service and Postgres installation only. You do not require a remotely managed runtime environment for ADL to function.

Create ADL directories

The following table lists the directories that must be created when using the ADL.

Considerations:

- The folders must be created in the directory specified in the southbound configuration file (see [ADL Configuration](#)).
- Create the directories only for the Data Loader types that are in use.

Note: By default, all the Data Loader Types have the same processing priority of 99 (prefix). This can be changed to get precedence in the processing. For example, 01~FamilyDataLoader.

Data Loader Name	Folder Name
Family Data Loader	FamilyDataLoader
Equipment and Functional Location Loader	EquipmentFunctionalLocationLoader
Taxonomy Data Loader	TaxonomyLoader
Work History Loader	WorkHistoryLoader
Production Loss Analysis (PLA) 1 - Admin	PLAAdminBatchDataLoader
Production Loss Analysis (PLA) 2 - Event	PLAEventBatchDataLoader
Production Loss Analysis (PLA) 3 - Plan	PLAPlanBatchDataLoader
Root Cause Analysis (RCA)	RCABatchDataLoader
System Reliability Data Loader	SystemReliabilityBatchDataLoader
Asset Criticality Analysis (ACA Checklist)	ACACheckListDataLoader
Asset Criticality Analysis (ACA)	ACAMatrixDataLoader
GIS Data Loader	GISDATALOADER
Policy Instance Data Loader	PolicyInstanceBatchDataLoader
Role Data Loader	RolesDataLoader

Data Loader Name	Folder Name
Rounds Allowable Values	AllowableValuesBatchDataLoader
Rounds Readings	ReadingsBatchDataLoader
Rounds Routes	RouteBatchDataLoader
Rounds Templates and Template Groups	TemplateBatchDataLoader
Inspection Management (IM) Assets	IMBatchAssetDataLoader
Inspection Management (IM) Functional Location	IMBatchFLDataLoader
RBI Components To TML Groups Relationship	RBITMBatchDataLoader
Risk Based Inspection (RBI) 580	RBI580BatchDataLoader
Risk Based Inspection (RBI) 581	RBI581BatchDataLoader
Risk Based Inspection (RBI) Corrosion Loop	RBICorrosionLoopBatchDataLoader
Thickness Monitoring (TM) Equipment	TMBatchAssetDataLoader
Thickness Monitoring (TM) Functional Location	TMBatchFLDataLoader
Thickness Monitoring (TM) Piping Equipment	TMBatchPipingAssetDataLoader
Thickness Monitoring (TM) Piping Functional Location	TMBatchPipingFLDataLoader
Generation Availability Analysis (GAA) GADS Amplification Codes	GAAAmplificationCodeDataLoader
Generation Availability Analysis (GAA) GADS Cause Code	GAACauseCodeDataLoader
Generation Availability Analysis (GAA) Events	GAAEventsDataLoader
Calibration Management	CalibrationBatchDataLoader
Hazard Analysis	HazardAnalysisBatchDataLoader
Asset Strategy Management (ASM)	AsmDataLoader
Asset Strategy Management (ASM) Template	AsmTemplateDataLoader
Failure Modes and Effects Analysis (FMEA)	FMEAAalysisDataLoader
Failure Modes and Effects Analysis (FMEA) Analysis Templates	FMEAAalysisTemplateDataLoader
Failure Modes and Effects Analysis (FMEA) Asset Templates	FMEAAsetTemplateDataLoader
Reliability Centered Maintenance (RCM)	RCMAnalysisDataLoader
Reliability Centered Maintenance (RCM) Analysis Template	RCMAnalysisTemplateDataLoader
Risk Matrix	RiskMatrixDataLoader
GAA Wind Asset Hierarchy	GAAWindAssetHierarchyDataLoader
GAA Wind Events	GAAWindEventDataloader

Data Loader Name	Folder Name
GAA Wind Sub Group Capacity	GAAWindSubgroupCapacityDataLoader
Rounds Pro - Picklist Dataloader	PicklistDataloader
Rounds Pro - Route Master Dataloader	RouteMasterDataloader
Rounds Pro - Step Dataloader	StepDataloader
Rounds Pro - Step Conditions	StepConditionDataloader
Rounds Pro - Step Template	StepTemplateDataloader

Chapter 4

NextGen ETL Account Management

Topics:

- [Account Management](#)
- [Access the Account Settings Page](#)
- [User Management](#)
- [Account Roles](#)
- [User Addition, Editing, Removal](#)
- [Account Advanced Security Settings](#)

Account Management

The APM Connect Administrators are provisioned with an account within their Boomi tenant and provided administrator access. As an administrator, you can add additional users, create custom roles, assign default or custom roles to users, change security options for the account, among other administrative options.

Access the Account Settings Page

Procedure

1. Sign in to your Boomi Platform Integration account.
2. Select **Settings>Account Information and Setup**.
The **Settings** page opens.

User Management

Procedure

1. Open the **Account Settings** page.
2. In the left pane, under **Account Access**, select **User Management**.
The **User Management** page opens.

Account Roles

Boomi has predefined roles that can be assigned to a user. As an account administrator, you can create custom roles for your users. Refer to the Boomi documentation if you want to configure your own custom roles.

In addition to the predefined roles from Boomi and any custom roles created by your account administrators, GE has defined roles that have permissions designed for the APM Connect implementation and usage of Boomi. The following roles are defined by GE and have the following permissions:

- GE Vernova Services Integration Engineering -- This role should be used for services engineering extending or developing custom integrations.

Permission Name	Description
Atom Management	Atom configuration and administration.
Atom Management Read Access	Read access to Atom configuration and administration.
Build Read and Write Access	Build, write, and modify processes and components.
Dashboard	Access to the Dashboard.
Environment Management	Management of all environments and associated access.
Execute	Execute or retry available processes.
Integration Pack	Manage Integration Packs

Permission Name	Description
Packaged Component Management	Create and manage packaged components.
Packaged Component Deployment	Deploy packaged components to environments.
Process Library	Manage Process Library.
Scheduling	Manage configured process schedules.
View Audit Logs	View and download audit logs.
View Data	View data in process reporting.
View Results	View and monitor process execution activity and logs.

- GE Vernova Services Integration Implementor -- This role should be used for services engineering deploying prepackaged integrations.

Permission Name	Description
Atom Management	Atom configuration and administration.
Atom Management Read Access	Read access to Atom configuration and administration.
Dashboard	Access to the Dashboard.
Environment Management	Management of all environments and associated access.
Execute	Execute or retry available processes.
Packaged Component Deployment	Deploy packaged components to environments.
Scheduling	Manage configured process schedules.
View Audit Logs	View and download audit logs.
View Data	View data in process reporting.
View Results	View and monitor process execution activity and logs.

- GE Vernova Support Engineer -- This role should be used for frontline support staff who need the ability to troubleshoot as built integrations.

Permission Name	Description
Atom Management Read Access	Read access to Atom configuration and administration.
Dashboard	Access to the Dashboard.
Execute	Execute or retry available processes.
Scheduling	Manage configured process schedules.
View Audit Logs	View and download audit logs.
View Data	View data in process reporting.
View Results	View and monitor process execution activity and logs.

User Addition, Editing, Removal

For details on adding, editing, or removing a user, refer to the Boomi documentation.

Account Advanced Security Settings

Boomi offers additional account settings that are not enabled by default and are optional. Refer to the Boomi documentation for the advanced security options, such as SSO enablement, Multi-Factor Authentication, and advanced session controls.

Chapter 5

Data Loaders

Topics:

- [General Information](#)
- [APM Family Data Loader](#)
- [Equipment and Functional Location Data Loader](#)
- [Taxonomy Data Loader](#)
- [Work History Data Loader](#)
- [APM Connect Data Loader Logs](#)

General Information

Requirements for APM Connect Data Loaders

All APM Connect Data Loaders have the same mapping and security settings requirements.

Important: To achieve best performance in the ingestion process, APM Connect recommends ingestion of maximum file size to be 10 MB. However, there are circumstances that may require larger files for ingestion. For such use cases, APM Connect allows file sizes up to 30 MB. If the file size exceeds 30 MB, an error message appears indicating that maximum file size has reached and the file is not processed. Additionally, there will be a check for file sizes in uncompressed state to ensure that file size does not to exceed 100 MB.

Note: File size, and data model complexity are two variables of data ingestion performance. Ingesting smaller files and lower complexity data models will assist in improving the performance.

Security Settings

The Security User performing the data load operation must be associated with either the MI Data Loader User or MI Data Loader Admin Security Role.

Mapping

The Data Loaders map the datasheet columns in the Excel workbook to fields in APM families by field ID. The captions may be changed as needed, but do not change the field IDs.

About Populating Site Reference Data

The APM Family Data Loader can be used to populate the Site Reference on Equipment and Functional Location records in APM.

About This Task

The APM Family Data Loader populates the **ENTY_KEY** system field and the **MI_SITE_KEY** system field associated with the Site Reference value to be populated. On asset records, the Site Reference is stored in the **MI_SITE_KEY** field, a system field in APM. The APM Data Loader uses the Site Name (**MI_SITE_NAME**) to translate the value to the corresponding Site Key and populate the **MI_SITE_KEY** field; therefore, you do not need to know the key to be able to populate the site reference. This functionality is important because this value can change from one database to another.

Procedure

1. On the data worksheet, add a column that contains **MI_SITE_NAME** in the column name. For example if you are working with a relationship, where a distinction needs to be made regarding which family is associated with each column, then the column name will be prefaced with the Family ID. As shown in the following image, the column name might take

the form MI_EQUIP000|MI_SITE_NAME, where MI_EQUIP000 is the Family ID.

C	D	E
Technical Number	CMMS System	Site Reference Name
000 MI_EQUIP000_EQUIP_TECH_NBR_C	MI_EQUIP000 MI_EQUIP000_SAP_SYSTEM_C	MI_EQUIP000 MI_SITE_NAME
DC-PMP-574000	Houston, TX	Houston, TX

2. Enter the site name to designate the site by which the asset record, once loaded into APM, will be filtered.
3. Continue populating the source workbook, and then run the data loader.

APM Family Data Loader

The APM Family Data Loader General Loading Strategy

This section describes any prerequisites to loading the data and the order in which the data will be loaded.

Before You Begin

1. Determine Load Type: Single Family or Two Related Families.
The APM Family Data Loader supports loading records into a single family, or you can load records into one family and records into another family and link the two records together. The type of data that you want to load will determine the sample template with which you will start.
2. Determine What Families and Relationships to Populate.
You can determine which families are available and how families are related in Family Management. To access Family Management:

Procedure

1. Determine if you want to load data into a single family or into two families that are related to each other.
2. Access a sample APM Family Data Loader source file based on the type of load determined in step 1 on page 59.
3. Determine what families and or relationships you want to populate using the APM Family Data Loader.
4. Export the metadata that reflects the metadata definition for the family or families into which you want to load data.
5. Populate the **Configuration** worksheet.
6. Populate the column headers of the **<Data>** worksheet using the exported metadata.
7. As needed, modify the worksheets to populate unit of measure to apply the correct unit of measure to any of the numeric fields.
8. As needed, modify the worksheets to populate time zones to convert any date or time fields to the correct time zone.

About the APM Family Data Loader Workbook Layout and Use

This section provides a high-level overview and explanation of how the data loader workbook is constructed.

In order to import data using the APM Family Data Loader, APM provides an Excel workbook that must be used to perform the data load.

The following table lists the worksheets that are included in the `APM Family.xlsx` workbook.

Worksheet	Description
Configuration	The Configuration worksheet is needed to describe the type of data that you will be loading and how that data should be handled during the data load.
<data>	Where you specify the actual data to be loaded.

Each worksheet in the APM Data Loader workbook contains field values that can be mapped to the appropriate APM Family Data Loader family/field.

Configuration Worksheet

The Configuration worksheet tells the APM Family Data Loader what types of data are being loaded and how the data is to be loaded, and is standard for all data loads regardless of the type of data that you are loading. The following table outlines the options that are valid or the values that are expected in each of the columns on the Configuration worksheet.

Field Caption	Field ID	Data Type (Length)	Comments
Number of Rows to Chunk	OPTION_NUMBER_ROWS_TO_CHUNK	Character	Option to break-up or chunk data.
Load Data From Worksheet	LOAD_DATA_WORKSHEET	Boolean	Identifies if data from the corresponding worksheet identified in the Data Worksheet ID column will be loaded or not. <ul style="list-style-type: none"> • True: The corresponding worksheet will be processed. • False: The corresponding worksheet will not be processed.
Data Worksheet ID	DATA_WORKSHEET_ID	Character	This column contains the name of the <data> worksheet where the actual data is located. It needs to have the same name as the <data> worksheet in the data loader workbook.

Field Caption	Field ID	Data Type (Length)	Comments
Batch Size	BATCH_SIZE	Character	<p>Modifying this field is required to determine the number of records processed in each batch. Enter the batch size you want, and the Data Loader will process that many records per batch.</p> <p>For example, if you want to use a batch size of 100, enter 100, and the data loader will process 100 records per batch.</p> <p>Note: The recommended batch size is 100. If the Batch Size column is removed from the source workbook, the data loader will default to a batch size of 100.</p> <p>In addition to processing the data in batches, the log file reports progress by batch.</p>
Primary Family ID	PRIMARY_FAMILY_ID	Character	<p>Depending on the type of data that you are working with, this will contain the Relationship Family ID or the Entity Family ID. You can also allow the data in source file to determine the Family ID by encapsulating the Field ID that contains the Family ID data in brackets (<>).</p> <p>For example, if in the <data> worksheet there is a column with an ID of PRIMARY_FAMILY_ID, where each row contains the corresponding Family ID, then in this column you should put the value of <PRIMARY_FAMILY_ID>.</p> <p>If the Family ID in the Meridium, Inc. metadata contains spaces, then you have to use this feature.</p>

Field Caption	Field ID	Data Type (Length)	Comments
Primary Family Key Fields	PRIMARY_FAMILY_KEY_FIELDS	Character	<p>This column contains the Field IDs associated with the Primary Family that are used to uniquely identify a record. If more than one field is to be used, then each Field ID needs to be separated by a (Pipe) character. In the case where you are loading data into a relationship, if no keys fields exist or are used, use the <none> constant.</p> <p>If the Primary Action is ACTION_INSERTONLY, then no key fields need to be specified, so you can use the <none> constant.</p>
Family Type	FAMILY_TYPE	Character	The value in this column should be Entity or Relationship depending on the type of data that is being loaded.
Predecessor Family ID	PRED_FAMILY_ID	Character	When the Family Type is Relationship, this column will contain the value of the Entity Family ID that is the predecessor in the relationship. Otherwise, it should contain the <none> constant. You can also use the data in each of the rows to determine the Predecessor Family ID.
Predecessor Family Key Fields	PRED_FAMILY_KEY_FIELDS	Character	<p>This column contains the Field ID or IDs associated with the Predecessor Family that are used to uniquely identify the predecessor record. If more than one field is to be used, then each Field ID needs to be separated by a (Pipe) character.</p> <p>If the Predecessor Action is ACTION_INSERTONLY, then no key fields need to be specified, so you can use the <none> constant.</p>
Successor Family ID	SUCC_FAMILY_ID	Character	When the Family Type is Relationship, this column will contain the value of the Entity Family ID that is the successor in the relationship. Otherwise, it should contain the <none> constant. You can also use the data in each of the rows to determine the Successor Family ID.

Field Caption	Field ID	Data Type (Length)	Comments
Successor Family Key Fields	SUCC_FAMILY_KEY_FIELDS	Character	<p>This column contains the Field ID or IDs associated with the Successor Family that are used to uniquely identify the successor record. If more than one field is to be used, then each Field ID needs to be separated by a (Pipe) character.</p> <p>If the Successor Action is ACTION_INSERTONLY, then no key fields need to be specified, so you can use the <none> constant.</p>
Primary Action	PRIMARY_ACTION	Character	<p>The value in this column will determine the action that will be applied to the Primary Family records. If the Family Type is Entity, then the possible values are:</p> <ul style="list-style-type: none"> • ACTION_INSERTONLY • ACTION_INSERTUPDATE • ACTION_UPDATEONLY • ACTION_DELETE • ACTION_PURGE <p>Deleting a record and purging a record will both delete the current record, the difference being that the purge action will delete the record and all of the links or relationships tied to that record. The delete action will simply attempt to delete the record, and if it is related to another record, the delete will fail. If The Family Type is Relationship, then the possible values are:</p> <ul style="list-style-type: none"> • ACTION_INSERTONLY • ACTION_INSERTUPDATE • ACTION_UPDATEONLY • ACTION_DELETE

Field Caption	Field ID	Data Type (Length)	Comments
Predecessor Action	PRED_ACTION	Character	<p>The value in this column will determine the action that will be applied to the Predecessor Family records. The possible values are:</p> <ul style="list-style-type: none"> • ACTION_INSERTONLY • ACTION_INSERTUPDATE • ACTION_UPDATEONLY • ACTION_DELETE • ACTION_PURGE • ACTION_LOCATE <p>If The Family Type is Entity, then the values need to be</p> <ul style="list-style-type: none"> • ACTION_NONE
Successor Action	SUCC_ACTION	Character	<p>The value in this column will determine the action that will be applied to the Successor Family records. The possible values are:</p> <ul style="list-style-type: none"> • ACTION_INSERTONLY • ACTION_INSERTUPDATE • ACTION_UPDATEONLY • ACTION_DELETE • ACTION_PURGE • ACTION_LOCATE <p>If The Family Type is Entity, then the values need to be</p> <ul style="list-style-type: none"> • ACTION_NONE
Insert with Null Values?	OPTION_INSERT_ON_NULL	Boolean	When setting field values on a new record, if a value coming across is NULL, the field values will be set to NULL if this option is set to True.
Update with Null Values?	OPTION_UPDATE_ON_NULL	Boolean	When setting field values on an existing record, if a value coming across is NULL, the field values will be set to NULL if this option is set to True.

Field Caption	Field ID	Data Type (Length)	Comments
Replace an Existing Link?	OPTION_REPLACE_EXISTING_LINK	Boolean	<p>The Replace Existing Relationship option is used to determine how a relationship is to be maintained by its cardinality definition.</p> <p>For example, the relationship Location Contains Asset that is defined in the Configuration Manager. It has a cardinality defined as Zero or One to Zero or One, has a Location LP-2300, and contains the Asset P-2300. If, in the data load, you assign the Asset P-5000 to be contained in the Location LP-2300, and you have set the Replace Existing Link property to True, then the data loader will link P-5000 to LP-2300 and unlink P-2300 from LP-2300. This assumes that P-5000 is not currently linked to another location. The same is true for a relationship that is defined as Zero or One to Zero or Many, or Zero or Many to Zero or One.</p>
Allow Change of Family?	OPTION_ALLOW_CHANGE_OF_FAMILY	Boolean	<p>Allows the data loader to move an entity from one family to another.</p> <p>For example, this would allow an entity that is currently assigned to the Centrifugal Pump family to be moved to the Reciprocating Pump family.</p> <p>All relationships will be maintained as long as the family to which the entity is being moved allows the same relationships.</p> <p>Note: Because of the extra processing required, by selecting this option, the interface performance will decrease.</p>

<Data> Worksheet

There is no preexisting format that must be adhered to on the <data> worksheet, because the Data Loader operates on a flexible framework. Field captions and ID are determined based on the data that you want to load.

Use the metadata exported from APM to construct the <data> worksheet, to populate the rows with the actual data that will be loaded.

Important: If a field is calculated in APM, it cannot be populated through the data loader. If you attempt to load these fields, a warning will appear in the log.

Steps: Export Metadata

Get a copy of the metadata definitions for the family or families that you will be working with to load data.

1. Login to APM.
2. On the left navigation menu, select **Admin**, then select **Configuration Manager**, and then select **Export**.
3. At the top of the page, in the **File Name** box, enter a file name and in the **File Type** box, select **Excel (.xlsx)**.
4. In the **Select metadata type** box, select **Families, Fields and Field Behaviors**.
5. Select the family or families that you want to export and move them to the **Selected Items** list.

Tip: Be sure to order the families in the order in which you want the fields to appear in the export.

6. Select **Start Export**.

The metadata is exported, and can be used to populate the **<data>** worksheet.

7. Save the metadata.

Export Metadata to Load Thickness Measurements

If you want to load Thickness Measurements into APM, because Thickness Measurements needs to be related to a Thickness Measurement Location, you must also export that family along with the Has Measurements relationship family.

1. Log in to APM.
2. On the left navigation menu, select **Admin**, then select **Configuration Manager**, and then select **Export**.
3. At the top of the page, in the **File Name** box, enter a file name (for example, `TM Measurements Metadata`).
4. In the **File Type** box, select **Excel (.xlsx)**.
5. In the **Select metadata type** box, select **Families, Fields, Fields Behaviors**, and then select the following families:

- **Thickness Measurement Location**
- **Thickness Measurement**
- **Has Measurements.**

Tip: Export the families in this order. This is how the fields appear in the export file.

Configuration Manager \

File Name: TM Measurements Meta File Type: Excel(.xlsx) Include underlying Query/Dataset/Subreports Start Export

Available Items
Families, Fields and Field Behaviors

- Account Classes
- Account Owner
- Accumulates Capacity Incident
- Action
- Action 1

Selected Items

- Thickness Measurement Location
- Thickness Measurement
- Has Measurements

6. Select **Start Export**.
The metadata is exported, and can be used to populate the **<data>** worksheet.

7. Save the metadata.
This exported metadata, is used to build source file template.

Configure the Data Loader Source File to Use Units of Measure

Sometimes the data that is being loaded, is in a different unit of measure than the one associated with the corresponding field in APM. When this is the case, the APM Family Data Loader allows for you to specify the unit of measure that is tied to a specific row and column. This is done by copying the column to which the unit of measure is tied, and then adding the suffix |UOM to the end of the Column ID. Then, in the data, specify the unit of measure ID for the data being loaded. This unit of measure ID needs to be a valid unit of measure as defined in APM, and a valid conversion needs to be specified for the unit of measure specified and the field's unit of measure. Please note that if a unit of measure is not specified, then it will use the field's unit of measure, as defined in APM.

Configure the Data Loader Source File to use Time Zones

Sometimes date and time data that is being loaded was collected in a different time zone than the time zone associated with the current user. When this is the case, the APM Family Data Loader allows you to specify the time zone that is tied to a specific row and column. This is done by copying the column to which the time zone is tied, and then adding the suffix |TZ to the end of the Column ID. Then, in the data, specify the time zone for the data being loaded. A valid list of time zones can be found in the Microsoft .NET documentation. Please note that if a time zone is not specified, then it will use the time zone defined for the current user.

Example APM Family Workbooks

In addition to the APM Family Data Loader workbook, you can access an example workbook Foundation_APM_Data_Loader-Health Indicators and Readings example.xlsx. This example workbook illustrates how you can use the APM Family Data Loader to load records into a defined APM family and link records in one family to another. You can use the information in this example as a model to configure or define templates for loading data into any baseline or custom family.

The data loader in this example creates Health Indicator records in APM, links the Health Indicator records to Equipment records, and then links the Health Indicator records to Health Indicator Mapping records. Finally, the data loader loads Readings for one of the Health Indicators. In addition, the example spreadsheet includes how you can use a reference worksheet to store list values and other reference information that users can use when populating the data loader template with data.

Populate the Configuration Worksheet

The Configuration Worksheet tells the APM Family Data Loader what types of data are being loaded and how the data is to be loaded.

Populate the HealthIndicators Worksheet

The HealthIndicators worksheet is populated with the actual Health Indicator records you want to load into APM.

Populate the HealthIndicatorsEquipment Worksheet

The HealthIndicatorsEquipment worksheet is populated with the key field values for the Equipment records to which the Health Indicators on the HealthIndicators worksheet will be linked once loaded into APM.

Populate the HealthIndicatorMappings Worksheet

The HealthIndicatorMappings worksheet is populated with the Health Indicator Mappings to load into APM.

Populate the HealthIndicatorReadings Worksheet

The HealthIndicatorReadings worksheet is populated with the actual Health Indicators data you want to load into APM.

On this worksheet, Column C illustrates a feature of the APM Family Data Loader where the unit of measure for a given field can be indicated, so that it can be converted to the baseline unit of measure if needed. Assume, for example, that the MI_TSVALUE_VALUE_N field was defined in APM as being stored in PSIG, but the data in the spreadsheet was represented by BAR(G). As shown in the following image, you can add the UOM column to indicate to that the unit of measure for the source data is BAR(G). When this column is added, the APM Family Data Loader will convert the data from BAR(G) to PSIG (assuming that there is a unit of measure conversion defined for this in APM).

Tip: For more information, refer to the units of measure documentation.

1	Name	Value (Numeric)	Value Unit of Measure	Timestamp	Timestamp Timezone
2	MI_HLTH_IND MI_HLTH_IND_ID_C	MI_HI_VALUE MI_TSVALUE_VALUE_N	MI_HI_VALUE MI_TSVALUE_VALUE_N UOM	MI_HI_VALUE MI_TSVALUE_TIMESTAMP_D	MI_HI_VALUE MI_TSVALUE_TIMESTAMP_D TZ
3	EQ03 Cyclone Pressure - (psig)	26.35449028	BAR(G)	2014-08-18 07:00:00	Central Standard Time
4	EQ03 Cyclone Pressure - (psig)	26.77112961	BAR(G)	2014-08-18 08:00:00	Central Standard Time
5	EQ03 Cyclone Pressure - (psig)	27.18776894	BAR(G)	2014-08-18 09:00:00	Central Standard Time
6	EQ03 Cyclone Pressure - (psig)	27.60440826	BAR(G)	2014-08-18 10:00:00	Central Standard Time
7	EQ03 Cyclone Pressure - (psig)	28.02104769	BAR(G)	2014-08-18 11:00:00	Central Standard Time
8	EQ03 Cyclone Pressure - (psig)	28.43768692	BAR(G)	2014-08-18 12:00:00	Central Standard Time
9	EQ03 Cyclone Pressure - (psig)	28.85432625	BAR(G)	2014-08-18 13:00:00	Central Standard Time
10	EQ03 Cyclone Pressure - (psig)	29.27096558	BAR(G)	2014-08-18 14:00:00	Central Standard Time
11	EQ03 Cyclone Pressure - (psig)	29.68760681	BAR(G)	2014-08-18 15:00:00	Central Standard Time
12	EQ03 Cyclone Pressure - (psig)	30.10424614	BAR(G)	2014-08-18 16:00:00	Central Standard Time
13	EQ03 Cyclone Pressure - (psig)	30.52088547	BAR(G)	2014-08-18 17:00:00	Central Standard Time
14	EQ03 Cyclone Pressure - (psig)	30.9375248	BAR(G)	2014-08-18 18:00:00	Central Standard Time
15	EQ03 Cyclone Pressure - (psig)	31.35416412	BAR(G)	2014-08-18 19:00:00	Central Standard Time
16	EQ03 Cyclone Pressure - (psig)	31.77080345	BAR(G)	2014-08-18 20:00:00	Central Standard Time
17	EQ03 Cyclone Pressure - (psig)	32.18744278	BAR(G)	2014-08-18 21:00:00	Central Standard Time
18	EQ03 Cyclone Pressure - (psig)	32.60408401	BAR(G)	2014-08-18 22:00:00	Central Standard Time
19	EQ03 Cyclone Pressure - (psig)	33.02072144	BAR(G)	2014-08-18 23:00:00	Central Standard Time
20	EQ03 Cyclone Pressure - (psig)	33.43736267	BAR(G)	2014-08-19 00:00:00	Central Standard Time
21	EQ03 Cyclone Pressure - (psig)	33.85400009	BAR(G)	2014-08-19 01:00:00	Central Standard Time

Additionally, column E of the HealthIndicatorReadings worksheet illustrates how time zones can be configured. Notice the appendage to the field name as shown in the following image. Adding a column where the Field ID is appended with a |TZ indicates the timezone of the source column data.

Note: If a timezone is not specified, any Date and Time field values are assumed to be in the same timezone as the user who is loading the data.

	B	C	D	E	F	G	H
1	Value (Numeric)	Value Unit of Measure	Timestamp	Timestamp Timezone			
2	MI_HI_VALUE MI_TSVALUE_VALUE_N	MI_HI_VALUE MI_TSVALUE_VALUE_N UOM	MI_HI_VALUE MI_TSVALUE_TIMESTAMP_D	MI_HI_VALUE MI_TSVALUE_TIMESTAMP_D TZ			
3	26.35449028	BAR(G)	2014-08-18 07:00:00	Central Standard Time			
4	26.77112961	BAR(G)	2014-08-18 08:00:00	Central Standard Time			
5	27.18776894	BAR(G)	2014-08-18 09:00:00	Central Standard Time			
6	27.60440826	BAR(G)	2014-08-18 10:00:00	Central Standard Time			
7	28.02104759	BAR(G)	2014-08-18 11:00:00	Central Standard Time			
8	28.43768692	BAR(G)	2014-08-18 12:00:00	Central Standard Time			
9	28.85432625	BAR(G)	2014-08-18 13:00:00	Central Standard Time			
10	29.27096558	BAR(G)	2014-08-18 14:00:00	Central Standard Time			
11	29.68760691	BAR(G)	2014-08-18 15:00:00	Central Standard Time			
12	30.10424614	BAR(G)	2014-08-18 16:00:00	Central Standard Time			
13	30.52088547	BAR(G)	2014-08-18 17:00:00	Central Standard Time			
14	30.9375248	BAR(G)	2014-08-18 18:00:00	Central Standard Time			
15	31.35416412	BAR(G)	2014-08-18 19:00:00	Central Standard Time			
16	31.77080345	BAR(G)	2014-08-18 20:00:00	Central Standard Time			
17	32.18744278	BAR(G)	2014-08-18 21:00:00	Central Standard Time			
18	32.60408211	BAR(G)	2014-08-18 22:00:00	Central Standard Time			
19	33.02072144	BAR(G)	2014-08-19 00:00:00	Central Standard Time			
20	33.43736077	BAR(G)	2014-08-19 01:00:00	Central Standard Time			
21	33.85400010	BAR(G)	2014-08-19 02:00:00	Central Standard Time			

Equipment and Functional Location Data Loader

About the Equipment and Functional Location Data Loader

The Equipment and Functional Location Data Loader allows a user to import data from an Excel workbook. The user is able to build out the asset hierarchy based on structure defined in the Excel workbook.

About the Equipment and Functional Location Data Loaders Data Model

The data for Equipment and Functional Location is loaded from a single Excel workbook containing multiple worksheets. This includes Functional Locations and Equipment.

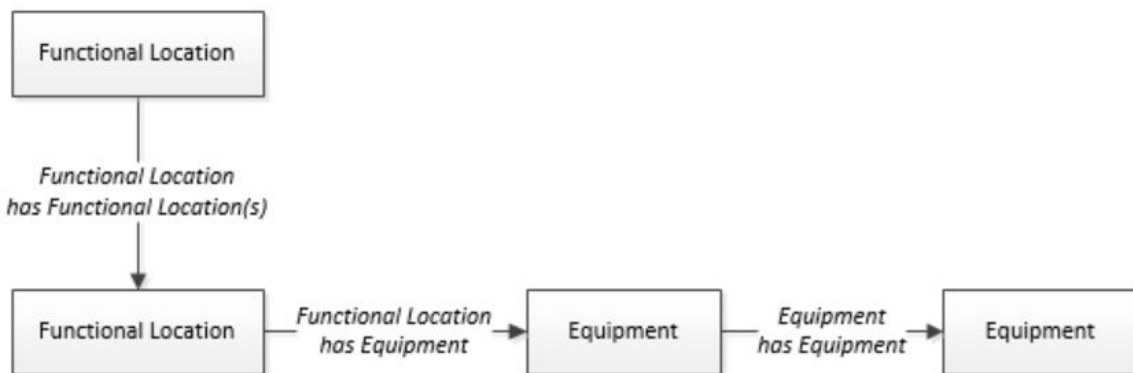

The Functional Location can be linked to a parent Functional Location using the relationship Functional Location Has Functional Location(s).

The Equipment and Functional Location Data Loader General Loading Strategy

This topic describes any prerequisites to loading the data and the order in which the data will be loaded for Equipment and Functional Location Data Loaders.

Before You Begin

Equipment Taxonomy data must be present prior to loading Equipment and Functional Location data.

About This Task

Note: Before reading this section, refer to the Data Model section.

The Equipment and Functional Location data load must be performed in a specific sequence to successfully populate fields, create records, and link them to the predecessor and/or successor records.

Procedure

1. Create the Functional Location.
2. Create the Equipment.

The Equipment and Functional Location Data Loaders have the listed limitations.

- The Functional Location hierarchy can be constructed in the loader by assigning the parent Functional Location (superseding Functional Location) to the child record.
- CMMS-ID is a required field that is intended to identify the original source of the data and part of the key value.
- After loading Equipment records into APM with a specific site reference, you cannot update the Equipment records to have global site references by reimporting the workbook with the site reference column updated to global on the Equipment worksheet. To update Equipment records to have global site references, you must update the predecessor Functional Locations with the site reference value *Global* on the worksheet.

In APM, records inherit their site references from their predecessor records. Additionally, when the Equipment and Functional Location Data Loader is run, it loads Equipment records first, and then loads Functional Location records. Therefore, to change the equipment record's site reference to global, you would need to re-import the workbook with the Functional Location record indicating a *Global* site reference.

About the Equipment and Functional Location Data Loaders Workbook Layout and Use

This section provides a high-level overview and explanation of how the data loader workbook is constructed.

In order to import data using the Equipment and Functional Location Data Loaders, APM provides an Excel workbook, `Equipment and Functional Location.xlsx`, which supports baseline data loading of equipment and functional locations in APM. This workbook must be used to perform the data load.

The master Excel workbook contains one worksheet for each node that will be populated in the data model.

The following table lists the worksheets that are included in the Equipment and Functional Location Data Loaders workbook.

Note: Worksheets in the workbook not being used may be left blank, but should not be deleted from the workbook.

Worksheet	Description
Configuration	The Configuration worksheet is needed to describe the type of data that you will be loading and how that data should be handled during the data load.
Equipment	This worksheet is used to specify data for import to the Equipment family.
EquipmentToSuperiorEquipment	This worksheet is used to link Equipment to Superior Equipment records.
FunctionalLocations	This worksheet is used to specify data for import to the Functional Location family.
FuncLocsToEquipment	This worksheet is used to link existing Functional Location records to existing Equipment records.
FuncLocsToSuperiorFuncLocs	This worksheet is used to link existing Functional Locations to superior Functional Locations.

Configuration Worksheet

The Configuration worksheet tells the Data Loader what types of data are being loaded and how the data is to be loaded, and is standard for all data loads regardless of the type of data that you are loading. The following table outlines the options that are valid or the values that are expected in each of the columns on the Configuration worksheet.

Field Caption	Field ID	Data Type (Length)	Comments
Number of Rows to Chunk	OPTION_NUMBER_ROWS_TO_CHUNK	Character	Option to break-up or chunk data.
Load Data From Worksheet	LOAD_DATA_WORKSHEET	Boolean	Identifies if data from the corresponding worksheet identified in the Data Worksheet ID column will be loaded or not. <ul style="list-style-type: none"> • True: The corresponding worksheet will be processed. • False: The corresponding worksheet will not be processed.
Data Worksheet ID	DATA_WORKSHEET_ID	Character	This column contains the name of the <data> worksheet where the actual data is located. It needs to have the same name as the <data> worksheet in the data loader workbook.

Field Caption	Field ID	Data Type (Length)	Comments
Batch Size	BATCH_SIZE	Character	<p>Modifying this field is required to determine the number of records processed in each batch. Enter the batch size you want, and the Data Loader will process that many records per batch.</p> <p>For example, if you want to use a batch size of 100, enter 100, and the data loader will process 100 records per batch.</p> <p>Note: The recommended batch size is 100. If the Batch Size column is removed from the source workbook, the data loader will default to a batch size of 100.</p> <p>In addition to processing the data in batches, the log file reports progress by batch.</p>
Primary Family ID	PRIMARY_FAMILY_ID	Character	<p>Depending on the type of data that you are working with, this will contain the Relationship Family ID or the Entity Family ID. You can also allow the data in source file to determine the Family ID by encapsulating the Field ID that contains the Family ID data in brackets (<>).</p> <p>For example, if in the <data> worksheet there is a column with an ID of PRIMARY_FAMILY_ID, where each row contains the corresponding Family ID, then in this column you should put the value of <PRIMARY_FAMILY_ID>.</p> <p>If the Family ID in the Meridium, Inc. metadata contains spaces, then you have to use this feature.</p>

Field Caption	Field ID	Data Type (Length)	Comments
Primary Family Key Fields	PRIMARY_FAMILY_KEY_FIELDS	Character	<p>This column contains the Field IDs associated with the Primary Family that are used to uniquely identify a record. If more than one field is to be used, then each Field ID needs to be separated by a (Pipe) character. In the case where you are loading data into a relationship, if no keys fields exist or are used, use the <none> constant.</p> <p>If the Primary Action is ACTION_INSERTONLY, then no key fields need to be specified, so you can use the <none> constant.</p>
Family Type	FAMILY_TYPE	Character	The value in this column should be Entity or Relationship depending on the type of data that is being loaded.
Predecessor Family ID	PRED_FAMILY_ID	Character	When the Family Type is Relationship, this column will contain the value of the Entity Family ID that is the predecessor in the relationship. Otherwise, it should contain the <none> constant. You can also use the data in each of the rows to determine the Predecessor Family ID.
Predecessor Family Key Fields	PRED_FAMILY_KEY_FIELDS	Character	<p>This column contains the Field ID or IDs associated with the Predecessor Family that are used to uniquely identify the predecessor record. If more than one field is to be used, then each Field ID needs to be separated by a (Pipe) character.</p> <p>If the Predecessor Action is ACTION_INSERTONLY, then no key fields need to be specified, so you can use the <none> constant.</p>
Successor Family ID	SUCC_FAMILY_ID	Character	When the Family Type is Relationship, this column will contain the value of the Entity Family ID that is the successor in the relationship. Otherwise, it should contain the <none> constant. You can also use the data in each of the rows to determine the Successor Family ID.

Field Caption	Field ID	Data Type (Length)	Comments
Successor Family Key Fields	SUCC_FAMILY_KEY_FIELDS	Character	<p>This column contains the Field ID or IDs associated with the Successor Family that are used to uniquely identify the successor record. If more than one field is to be used, then each Field ID needs to be separated by a (Pipe) character.</p> <p>If the Successor Action is ACTION_INSERTONLY, then no key fields need to be specified, so you can use the <none> constant.</p>
Primary Action	PRIMARY_ACTION	Character	<p>The value in this column will determine the action that will be applied to the Primary Family records. If the Family Type is Entity, then the possible values are:</p> <ul style="list-style-type: none"> • ACTION_INSERTONLY • ACTION_INSERTUPDATE • ACTION_UPDATEONLY • ACTION_DELETE • ACTION_PURGE <p>Deleting a record and purging a record will both delete the current record, the difference being that the purge action will delete the record and all of the links or relationships tied to that record. The delete action will simply attempt to delete the record, and if it is related to another record, the delete will fail. If The Family Type is Relationship, then the possible values are:</p> <ul style="list-style-type: none"> • ACTION_INSERTONLY • ACTION_INSERTUPDATE • ACTION_UPDATEONLY • ACTION_DELETE

Field Caption	Field ID	Data Type (Length)	Comments
Predecessor Action	PRED_ACTION	Character	<p>The value in this column will determine the action that will be applied to the Predecessor Family records. The possible values are:</p> <ul style="list-style-type: none"> • ACTION_INSERTONLY • ACTION_INSERTUPDATE • ACTION_UPDATEONLY • ACTION_DELETE • ACTION_PURGE • ACTION_LOCATE <p>If The Family Type is Entity, then the values need to be</p> <ul style="list-style-type: none"> • ACTION_NONE
Successor Action	SUCC_ACTION	Character	<p>The value in this column will determine the action that will be applied to the Successor Family records. The possible values are:</p> <ul style="list-style-type: none"> • ACTION_INSERTONLY • ACTION_INSERTUPDATE • ACTION_UPDATEONLY • ACTION_DELETE • ACTION_PURGE • ACTION_LOCATE <p>If The Family Type is Entity, then the values need to be</p> <ul style="list-style-type: none"> • ACTION_NONE
Insert with Null Values?	OPTION_INSERT_ON_NULL	Boolean	When setting field values on a new record, if a value coming across is NULL, the field values will be set to NULL if this option is set to True.
Update with Null Values?	OPTION_UPDATE_ON_NULL	Boolean	When setting field values on an existing record, if a value coming across is NULL, the field values will be set to NULL if this option is set to True.

Field Caption	Field ID	Data Type (Length)	Comments
Replace an Existing Link?	OPTION_REPLACE_EXISTING_LINK	Boolean	<p>The Replace Existing Relationship option is used to determine how a relationship is to be maintained by its cardinality definition.</p> <p>For example, the relationship Location Contains Asset that is defined in the Configuration Manager. It has a cardinality defined as Zero or One to Zero or One, has a Location LP-2300, and contains the Asset P-2300. If, in the data load, you assign the Asset P-5000 to be contained in the Location LP-2300, and you have set the Replace Existing Link property to True, then the data loader will link P-5000 to LP-2300 and unlink P-2300 from LP-2300. This assumes that P-5000 is not currently linked to another location. The same is true for a relationship that is defined as Zero or One to Zero or Many, or Zero or Many to Zero or One.</p>
Allow Change of Family?	OPTION_ALLOW_CHANGE_OF_FAMILY	Boolean	<p>Allows the data loader to move an entity from one family to another.</p> <p>For example, this would allow an entity that is currently assigned to the Centrifugal Pump family to be moved to the Reciprocating Pump family.</p> <p>All relationships will be maintained as long as the family to which the entity is being moved allows the same relationships.</p> <p>Note: Because of the extra processing required, by selecting this option, the interface performance will decrease.</p>

Equipment Worksheet

On the Equipment worksheet, you will specify Equipment that you want to load into APM.

Note: Each row in this worksheet represents a unique asset. You should not include the same asset more than once.

Field Caption	Field Column Name	Data Type (Length)	Comment
Maintenance Plant	MI_EQUIP000_MAINT_PLANT_C	Character (50)	This field is required, and is used to group or batch the equipment records.
Equipment ID	MI_EQUIP000_EQUIP_ID_C	Character (225)	This is a key field.
Equipment Technical Number	MI_EQUIP000_EQUIP_TECH_NBR_C	Character (255)	None
CMMS System	MI_EQUIP000_SAP_SYSTEM_C	Character (255)	This is a key field.
Site Reference Name	MI_SITE_NAME	Character (255)	<p>Important: Site Reference records must preexist in APM. The data loader does not create Site Reference records, but simply provides foreign key data in the asset records, as determined in the source workbook. If the site reference record does not preexist, then you will receive an error.</p> <p>1. Enter the site name to designate which site the Equipment record, once loaded into APM, will be filtered by.</p> <p>-or-</p> <p>1. Enter *Global* to indicate a that the site reference should be left global. Meaning that it will not be filtered by site in APM.</p> <p>Note: Only super users are permitted to update Site Reference records.</p>
Equipment Short Description	MI_EQUIP000_EQUIP_SHORT_DESC_C	Character (255)	None
Equipment Long Description	MI_EQUIP000_EQUIP_LONG_DESC_T	Text	None
Object Type (Taxonomy Mapping Value)	MI_EQUIP000_OBJ_TYP_C	Character (50)	None
Equipment System Status	MI_EQUIP000_SYS_ST_C	Character (255)	None

Field Caption	Field Column Name	Data Type (Length)	Comment
Manufacturer	MI_EQUIP000_MFR_C	Character (255)	None
Model Number	MI_EQUIP000_MOD_NO_C	Character (255)	None
Equipment Serial Number	MI_EQUIP000_SN_C	Character (255)	None
Active	'MI_EQUIP000_ACTIVE_F	Logical	None
Equipment uniquely identified by SAP System - Equipment ID	MI_EQUIP000_UNIQUE_ID_C	Character (550)	<p>This field uniquely identifies the equipment using the format <CMMS System> - <Functional Location ID>. This value allows the Data Loader to associate records between the Meridium database and the Predix database.</p> <p>Note: You should not use this field if you have an on-premises implementation of APM.</p>

FunctionalLocations Worksheet

On the FunctionalLocations worksheet, you enter information for Functional Locations and the Functional Location hierarchy.

Note: Each row in this worksheet represents a unique asset. You should not include the same asset more than once.

Field Caption	Field ID	Data Type (Length)	Comments
Maintenance Plant	MI_FNCLOC00_MAINT_PLN_T_C	Character (50)	None
Functional Location Internal ID	MI_FNCLOC00_INTERNAL_ID_C	Character (30)	This is a key field.
Functional Location	MI_FNCLOC00_FNC_LOC_C	Character (50)	None
CMMS System	MI_FNCLOC00_SAP_SYSTEM_C	Character (255)	This is a key field.

Field Caption	Field ID	Data Type (Length)	Comments
Site Reference Name	MI_SITE_NAME	Character (255)	<p>Important: Site Reference records must preexist in APM. The data loader does not create Site Reference records, but simply provides foreign key data in the asset records, as determined in the source workbook. If the site reference record does not preexist, then you will receive an error.</p> <p>1. Enter the site name to designate the site by which the Functional Location record, once loaded into APM, will be filtered.</p> <p>-or-</p> <p>1. Enter *Global* to indicate a that the site reference should be left global. Meaning that it will not be filtered by site in APM.</p> <p>Note: Only Super Users are permitted to update Site Reference records.</p>
Functional Location Description	MI_FNCLOC00_FNC_LOC_DESC_C	Character (255)	None
Functional Location Long Description	MI_FNCLOC00_FNC_LOC_LONG_DESC_C	Text	None
Object Type (Taxonomy Mapping Value)	MI_FNCLOC00_OBJ_TYP_C	Character (50)	None
System Status	MI_FNCLOC00_SYS_STATU S_C	Character (255)	None

Field Caption	Field ID	Data Type (Length)	Comments
Is a Process Unit?	SC_FNCLOC00_IS_A_PROC E_UNIT_L	Logical	None
Functional Location uniquely identified by SAP System - Functional Location Internal ID	MI_FNCLOC00_UNIQUE_ID _C	Character (550)	This field uniquely identifies the functional location using the format <CMMS System> - <Functional Location ID>. This value allows the Data Loader to associate records between the Meridium database and the Predix database. Note: You should not use this field if you have an on-premises implementation of APM.

FuncLocsToEquipment

Field Caption	Field ID	Data Type (Length)	Comments
Maintenance Plant	MI_FNCLOC00_MAINT_PLN T_C	Character (50)	None
Functional Location Internal ID	MI_FNCLOC00_INTERNAL_ ID_C	Character (30)	This is a key field.
Functional Location	MI_FNCLOC00 MI_FNCLOC00_FNC_LOC_ C	Character (50)	None
CMMS System	MI_FNCLOC00_SAP_SYSTE M_C	Character (255)	This is a key field. Functional Location CMMS System.
Functional Location uniquely identified by System - Functional Location ID	MI_FNCLOC00 MI_FNCLOC00_UNIQUE_ID _C	Character (550)	This field uniquely identifies the functional location using the format <CMMS System> - <Functional Location ID>. This value allows the Data Loader to associate records between the Meridium database and the Predix database. Note: You should not use this field if you have an on-premises implementation of APM.

Field Caption	Field ID	Data Type (Length)	Comments
Equipment ID	MI_EQUIP000_EQUIP_ID_C	Character (225)	This is a key field.
CMMS System	MI_EQUIP000_SAP_SYSTE M_C	Character (255)	This is a key field. Equipment CMMS System.
Equipment uniquely identified by System - Equipment ID	MI_EQUIP000 MI_EQUIP000_UNIQUE_ID_ C	Character (550)	This field uniquely identifies the equipment using the format <CMMS System> - <Equipment ID>. This value allows the Data Loader to associate records between the Meridium database and the Predix database. Note: You should not use this field if you have an on- premises implementation of APM.

FuncLocsToSuperiorFuncLocs

Field Caption	Field ID	Data Type (Length)	Comments
Maintenance Plant	<PRED_FAMILY_ID> MI_FNCLOC00_MAINT_PLN T_C	Character (50)	None
Functional Location Internal ID	<PRED_FAMILY_ID> MI_FNCLOC00_INTERNAL_ ID_C	Character (30)	This is a key field.
Functional Location	<PRED_FAMILY_ID> MI_FNCLOC00_FNC_LOC_ C	Character (50)	None
CMMS System	<PRED_FAMILY_ID> MI_FNCLOC00_SAP_SYSTE M_C	Character (255)	This is a key field. Functional Location CMMS System.

Field Caption	Field ID	Data Type (Length)	Comments
Functional Location uniquely identified by System - Functional Location ID	<PRED_FAMILY_ID> MI_FNCLOC00_UNIQUE_ID_C	Character (550)	This field uniquely identifies the functional location using the format <CMMS System> - <Functional Location ID>. This value allows the Data Loader to associate records between the Meridium database and the Predix database. Note: You should not use this field if you have an on-premises implementation of APM.
Predecessor Family ID	PRED_FAMILY_ID	Character (255)	None
Functional Location Internal ID	<SUCC_FAMILY_ID> MI_FNCLOC00_INTERNAL_ID_C	Character (30)	This is a key field.
Functional Location	<SUCC_FAMILY_ID> MI_FNCLOC00_FNC_LOC_C	Character (50)	None
CMMS System	MI_EQUIP000_SAP_SYSTEM_C	Character (255)	This is a key field. Equipment CMMS System.
Functional Location uniquely identified by System - Functional Location ID	<SUCC_FAMILY_ID> MI_FNCLOC00_UNIQUE_ID_C	Character (550)	This field uniquely identifies the functional location using the format <CMMS System> - <Functional Location ID>. This value allows the Data Loader to associate records between the Meridium database and the Predix database. Note: You should not use this field if you have an on-premises implementation of APM.
Successor Family ID	SUCC_FAMILY_ID	Character (255)	This is a key field.

EquipmentToSuperiorEquipment Worksheet

On the EquipmentToSuperiorEquipment worksheet, you specify the hierarchy between an Equipment and its Superior Equipment. This generates the relationships between the entities in the database.

Field Caption	Field ID	Data Type (Length)	Comments
Maintenance Plant	<PRED_FAMILY_ID> MI_EQUIP000_MAINT_PLA NT_C	Character (50)	This value identifies the plant responsible for maintenance. This field is not required to contain a value, but entering a value is recommended as it could be useful for searches or data analysis.
CMMS System	<PRED_FAMILY_ID> MI_EQUIP000_SAP_SYSTE M_C	Character (255)	This value identifies the parent family and EAM system as defined in APM.
Equipment ID	<PRED_FAMILY_ID> MI_EQUIP000_EQUIP_ID_C	Character (255)	This value identifies the parent family and equipment ID as defined in APM.
Predecessor Equipment Unique ID	<PRED_FAMILY_ID> MI_EQUIP000_UNIQUE_ID_ C	Character (550)	This field uniquely identifies the equipment using the format <CMMS System> - <Equipment ID>.
Predecessor Family ID	PRED_FAMILY_ID	Character (255)	This value identifies the parent family as defined in APM.
CMMS System	<SUCC_FAMILY_ID> MI_EQUIP000_SAP_SYSTE M_C	Character (255)	This value identifies the child family and EAM system as defined in APM.
Equipment ID	<SUCC_FAMILY_ID> MI_EQUIP000_EQUIP_ID_C	Character (255)	This value identifies the child family and equipment ID as defined in APM.
Successor Equipment Unique ID	<SUCC_FAMILY_ID> MI_EQUIP000_UNIQUE_ID_ C	Character (550)	This field uniquely identifies the equipment using the format <CMMS System> - <Equipment ID>.
Successor Family ID	SUCC_FAMILY_ID	Character (255)	This value identifies the child family as defined in APM. This is a key field.

The value of this field has the format YYYY-MO-DDTHH:MN:SS.ttt+OOOO, where:

- YYYY is the 4-digit year.
- MO is the 2-digit month.
- DD is the 2-digit day.
- HH is the 2-digit hour in 24-hour time.
- MN is the 2-digit minute.
- SS is the 2-digit second.

- ttt is the 3 digit thousandths of a second.
- OOOO is the 4-digit offset from UTC.

The Configuration worksheet is needed to describe the type of data that you will be loading and how that data should be handled during the data load.

Field Caption	Field ID	Data Type (Length)	Comments
Load Data From Worksheet	LOAD_DATA_WORKSHEET	Boolean	<p>Identifies if data from the corresponding worksheet identified in the Data Worksheet ID column will be loaded or not.</p> <ul style="list-style-type: none"> • True: the corresponding worksheet will be processed. • False: The corresponding worksheet will not be loaded into the Meridium database.
Data Worksheet ID	DATA_WORKSHEET_ID	Character	<p>This column contains the name of the <data> worksheet where the actual data is located. It needs to have the same name as the <data> worksheet in the data loader workbook.</p>
Batch Size	BATCH_SIZE	Character	<p>Modifying this field is required to determine the number of records processed in each batch. Enter the batch size you want, and the Data Loader will process that many records per batch.</p> <p>For example, if you want to use a batch size of 100, enter 100, and the data loader will process 100 records per batch.</p> <p>Note: The recommended batch size is 100. If the Batch Size column is removed from the source workbook, the data loader will default to a batch size of 100.</p> <p>In addition to processing the data in batches, the log file reports progress by batch.</p>

Taxonomy Data Loader

About the Taxonomy Data Loader

The Taxonomy Data Loader loads data from a standard Excel workbook into the Taxonomy data model. The data loader will create or update Taxonomy Categories, Classes, and Types based on the data in the Excel workbook.

About the Taxonomy Data Loader Data Model

The data for a Taxonomy location is loaded from a single Excel workbook containing a single worksheet.

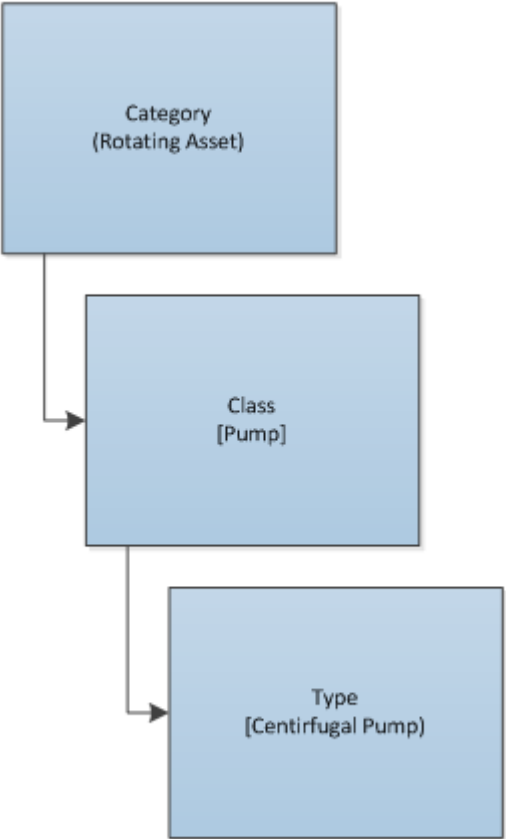

The Taxonomy Data Loader General Loading Strategy

This section describes any prerequisites to loading the data and the order in which the data will be loaded.

Before You Begin

As the taxonomy structure is a foundation for analysis and reporting, users should clearly understand the usage and data model for Taxonomy related records prior to implementing the Taxonomy structure.

About This Task

Note: Before reading this section, refer to the Data Model section.

The Taxonomy data load must be performed in a specific sequence to successfully populate fields, create records, and link them to the predecessor and/or successor records.

Procedure

1. Load Taxonomy Category.
2. Load Taxonomy Class.
3. Load Taxonomy Type.
4. Load Taxonomy Mapping Values.

About the Taxonomy Data Loader Workbook Layout and Use

This section provides a high-level overview and explanation of how the data loader workbook is constructed.

In order to import data using the Taxonomy Data Loader, GE Vernova provides an Excel workbook, *Taxonomy.xlsx*, which supports baseline data loading of Taxonomy in APM. This workbook must be used to perform the data load. On the Taxonomy worksheets, you will enter the information to load a taxonomy structure that will be assigned to assets within APM.

The baseline file is organized such that each row is capable of creating one node in the data model when all columns contain the appropriate values.

The following table lists the worksheets that are included in the Taxonomy Data Loader workbook.

Note: Worksheets in the workbook not being used may be left blank, but should not be deleted from the workbook.

Worksheet	Description
Configuration	The Configuration worksheet is needed to describe the type of data that you will be loading and how that data should be handled during the data load.
TaxonomyCategory	This worksheet is used to link Taxonomy Category data and Taxonomy Class data.
TaxonomyClass	This worksheet is used to link Taxonomy Class data and Taxonomy Type data.
TaxonomyMapping	This worksheet is used to link Taxonomy Type data and Taxonomy Mapping data.

Configuration Worksheet

The **Configuration** worksheet tells the data loader what types of data are being loaded and how the data is to be loaded, and is standard for all data loads regardless of the type of data that you are loading. The following table outlines the options that are valid or the values that are expected in each of the columns on the **Configuration** worksheet.

Field Caption	Field ID	Data Type (Length)	Comments
Load Data From Worksheet	LOAD_DATA_WORKSHEET	Boolean	<p>Identifies if data from the corresponding worksheet identified in the Data Worksheet ID column will be loaded or not.</p> <ul style="list-style-type: none"> • True: The corresponding worksheet will be processed. • False: The corresponding worksheet will not be processed.
Data Worksheet ID	DATA_WORKSHEET_ID	Character	<p>This column contains the name of the <data> worksheet where the actual data is located. It needs to have the same name as the <data> worksheet in the data loader workbook.</p>
Batch Size	BATCH_SIZE	Character	<p>Modifying this field is required to determine the number of records processed in each batch. Enter the batch size you want, and the Data Loader will process that many records per batch.</p> <p>For example, if you want to use a batch size of 100, enter 100, and the data loader will process 100 records per batch.</p> <p>Note: The recommended batch size is 100. If the Batch Size column is removed from the source workbook, the data loader will default to a batch size of 100.</p> <p>In addition to processing the data in batches, the log file reports progress by batch.</p>
Primary Family ID	PRIMARY_FAMILY_ID	Character	<p>Depending on the type of data that you are working with, this will contain the Relationship Family ID or the Entity Family ID. You can also allow the data in source file to determine the Family ID by encapsulating the Field ID that contains the Family ID data in brackets (<>).</p> <p>For example if in the <data> worksheet there is a column with an ID of PRIMARY_FAMILY_ID, where each row contains the corresponding Family ID, then in this column you should put the value of <PRIMARY_FAMILY_ID>.</p> <p>If the Family ID in the Meridium, Inc. metadata contains spaces, then you have to use this feature.</p>

Field Caption	Field ID	Data Type (Length)	Comments
Primary Family Key Fields	PRIMARY_FAMILY_KEY_FIELDS	Character	<p>This column contains the Field IDs associated with the Primary Family that are used to uniquely identify a record. If more than one field is to be used, then each Field ID needs to be separated by a (Pipe) character. In the case where you are loading data into a relationship, if no keys fields exist or are used, use the <none> constant.</p> <p>If the Primary Action is ACTION_INSERTONLY, then no key fields need to be specified, so you can use the <none> constant.</p>
Family Type	FAMILY_TYPE		The value in this column should be Entity or Relationship depending on the type of data that is being loaded.
Predecessor Family ID	PRED_FAMILY_ID	Character	When the Family Type is Relationship, this column will contain the value of the Entity Family ID that is the predecessor in the relationship. Otherwise, it should contain the <none> constant. You can also use the data in each of the rows to determine the Predecessor Family ID.
Predecessor Family Key Fields	PRED_FAMILY_KEY_FIELDS	Character	<p>This column contains the Field ID or IDs associated with the Predecessor Family that are used to uniquely identify the predecessor record. If more than one field is to be used, then each Field ID needs to be separated by a (Pipe) character.</p> <p>If the Predecessor Action is ACTION_INSERTONLY, then no key fields need to be specified, so you can use the <none> constant.</p>
Successor Family ID	SUCC_FAMILY_ID	Character	When the Family Type is Relationship, this column will contain the value of the Entity Family ID that is the successor in the relationship. Otherwise, it should contain the <none> constant. You can also use the data in each of the rows to determine the Successor Family ID.

Field Caption	Field ID	Data Type (Length)	Comments
Successor Family Key Fields	SUCC_FAMILY_KEY_FIELDS	Character	<p>This column contains the Field ID or IDs associated with the Successor Family that are used to uniquely identify the successor record. If more than one field is to be used, then each Field ID needs to be separated by a (Pipe) character.</p> <p>If the Successor Action is ACTION_INSERTONLY, then no key fields need to be specified, so you can use the <none> constant.</p>
Primary Action	PRIMARY_ACTION	Character	<p>The value in this column will determine the action that will be applied to the Primary Family records. If the Family Type is Entity, then the possible values are:</p> <ul style="list-style-type: none"> • ACTION_INSERTONLY • ACTION_INSERTUPDATE • ACTION_UPDATEONLY • ACTION_DELETE • ACTION_PURGE <p>Deleting a record and purging a record will both delete the current record, the difference being that the purge action will delete the record and all of the links or relationships tied to that record. The delete action will simple attempt to delete the record, and if it is related to another record, the delete will fail. If The Family Type is <i>Relationship</i>, then the possible values are:</p> <ul style="list-style-type: none"> • ACTION_INSERTONLY • ACTION_INSERTUPDATE • ACTION_UPDATEONLY • ACTION_DELETE

Field Caption	Field ID	Data Type (Length)	Comments
Predecessor Action	PRED_ACTION	Character	<p>The value in this column will determine the action that will be applied to the Predecessor Family records. The possible values are:</p> <ul style="list-style-type: none"> • ACTION_INSERTONLY • ACTION_INSERTUPDATE • ACTION_UPDATEONLY • ACTION_DELETE • ACTION_PURGE • ACTION_LOCATE <p>If The Family Type is Entity then the value needs to be ACTION_NONE</p> <p>.</p>
Successor Action	SUCC_ACTION	Character	<p>The value in this column will determine the action that will be applied to the Successor Family records. The possible values are:</p> <ul style="list-style-type: none"> • ACTION_INSERTONLY • ACTION_INSERTUPDATE • ACTION_UPDATEONLY • ACTION_DELETE • ACTION_PURGE • ACTION_LOCATE <p>If The Family Type is <i>Entity</i> then the value needs to be ACTION_NONE.</p>
Insert with Null Values?	OPTION_INSERT_ON_NULL	Boolean	When setting field values on a new record, if a value coming across is NULL, the field values will be set to NULL if this option is set to True.
Update with Null Values?	OPTION_UPDATE_ON_NULL	Boolean	When setting field values on an existing record, if a value coming across is NULL, the field values will be set to NULL if this option is set to True.

Field Caption	Field ID	Data Type (Length)	Comments
Replace an Existing Link?	OPTION_REPLACE_EXISTING_LINK	Boolean	<p>The Replace Existing Relationship option is used to determine how a relationship is to be maintained by its cardinality definition.</p> <p>For example, the relationship Location Contains Asset that is defined in the Configuration Manager. It has a cardinality defined as Zero or One to Zero or One, has a Location LP-2300, and contains the Asset P-2300. If, in the data load, you assign the Asset P-5000 to be contained in the Location LP-2300, and you have set the Replace Existing Link property to True, then the data loader will link P-5000 to LP-2300 and unlink P-2300 from LP-2300. This assumes that P-5000 is not currently linked to another location. The same is true for a relationship that is defined as Zero or One to Zero or Many, or Zero or Many to Zero or One.</p>
Allow Change of Family?	OPTION_ALLOW_CHANGE_OF_FAMILY	Boolean	<p>Allows the data loader to move an entity from one family to another.</p> <p>For example this would allow an entity that is currently assigned to the Centrifugal Pump family to be moved to the Reciprocating Pump family.</p> <p>All relationships will be maintained as long as the family to which the entity is being moved allows the same relationships.</p> <p>Note: Because of the extra processing required, by selecting this option, the interface performance will decrease.</p>

TaxonomyCategory

Note: Each row in this worksheet represents a single asset. You should not include the same asset more than once.

Field Caption	Field ID	Data Type (Length)	Comments
Taxonomy Category	SC_TAXOCATG_TAX_CATEG_C	Character (50)	This column is used for batching.
Taxonomy Category Description	SC_TAXOCATG_TAX_CATEG_DESC_C	Character (255)	None

TaxonomyClass

Note: Each row in this worksheet represents a single asset. You should not include the same asset more than once.

Field Caption	Field ID	Data Type (Length)	Comments
Taxonomy Category	SC_TAXOCATG_TAX_CATEG_C	Character (50)	This column is used for batching.
Taxonomy Class	SC_TAXOCLAS_TAX_CLASS_C	Character (50)	This is a key field.
Taxonomy Class Description	SC_TAXOCLAS_TAX_CLASS_DESC_C	Character (255)	None

TaxonomyType

Field Caption	Field ID	Data Type (Length)	Comments
Taxonomy Category	SC_TAXOCATG_TAX_CATEG_C	Character (50)	This column is used for batching.
Taxonomy Class	SC_TAXOCLAS_TAX_CLASS_C	Character (50)	This is a key field.
Taxonomy Type	SC_TAXOTYPE_TAX_TYPE_C	Character (50)	This is a key field.
Taxonomy Type Description	SC_TAXOTYPE_TAX_TYPE_DESC_C	Character (255)	None

TaxonomyMapping Worksheet

Field Caption	Field ID	Data Type (Length)	Comments
Taxonomy Mapping Category	SC_TAXOMAPP_TAX_CATEG_C	Character (50)	This column is used for batching.
Taxonomy Mapping Class	SC_TAXOMAPP_TAX_CLASSES_C	Character (50)	This is a key field.
Taxonomy Mapping Type	SC_TAXOMAPP_TAX_TYPE_C	Character (50)	This is a key field.
Taxonomy Mapping Value	SC_TAXOMAPP_TAX_MAPPING_VALUE_C	Character (255)	This is a key field.

Work History Data Loader

About the Work History Data Loader

The Work History Data Loader allows a user to load historical work order data from an Excel workbook. The loader will create the necessary work history and work history detail records

and link them to the corresponding equipment or functional location records as defined in the Excel workbook.

About the Work History Data Loader Data Model

The data for Work History and Work History detail families is loaded from a single Excel workbook containing a single worksheet. This includes Work History and Work History Detail.

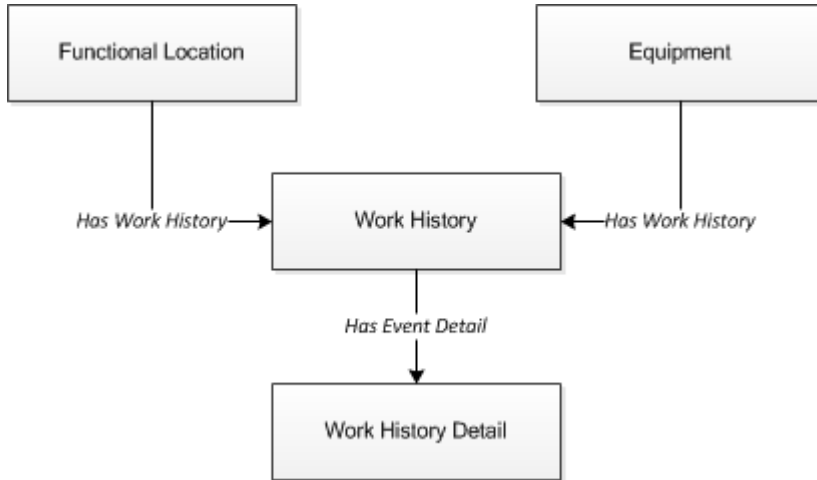

Relationships:

- The Work History records are linked to Equipment and/or Functional Location records via the relationship Has Work History [MIR_HSWKHST].
- The Work History Detail records will be related to the appropriate Work History records via the relationship family Has Event Detail [MIR_EVNTDET].

The Work History Data Loader General Loading Strategy

This section describes any prerequisites to loading the data and the order in which the data will be loaded.

About This Task

Note: Before reading this section, refer to the Data Model section.

The Work History and Work History Detail data load must be performed in a specific sequence to successfully populate fields, create records, and link them to the predecessor and/or successor records.

Procedure

1. Create or Update the Work History record.
2. Link the Work History record to the Asset ID (Equipment or Functional Location).
3. Create or Update the Work History Detail record.
4. Link the Work History Detail record to the associated Work History record.

Note: There can be multiple Work History Detail records for each Work History record.

Work History Data Loader Load Verification

Use this query in any APM database to populate an Excel format with the required data fields.

Work History Data Query

```
SELECT 'Customer Event Id' "Customer Event Id",
[MI_EVWKHIST].[MI_EVENT_ID]
"Event ID", [MI_EQUIP000].[MI_EQUIP000_EQUIP_ID_C]
"Equipment ID",
[MI_EQUIP000].[MI_EQUIP000_EQUIP_TECH_NBR_C] "Equipment
Technical Number",
[MI_FNCLOC00].[MI_FNCLOC00_FNC_LOC_C] "Functional
Location",
[MI_EVWKHIST].[MI_EVWKHIST_SAP_SYSTEM_C] "CMMS System",
[MI_EVWKHIST].[MI_EVWKHIST_ACTIV_CAUSE_C] "Activity
Cause",
[MI_EVWKHIST].[MI_EVWKHIST_ORDR_PM_ACT_DESC_C] "Activity
Type Description",
[MI_EVWKHIST].[MI_EVWKHIST_ORDR_PM_ACT_C] "Activity Type",
[MI_EVWKHIST].[MI_EVWKHIST_BRKDN_IND_F] "Breakdown
Indicator",
[MI_EVWKHIST].[MI_EVWKHIST_DETCT_MTHD_CD_C] "Detection
Method Code",
[MI_EVWKHIST].[MI_EVWKHIST_DETCT_MTHD_DESC_C] "Detection
Method Description",
[MI_EVWKHIST].[MI_EVWKHIST_EFFCT_CD_C] "Effect Code",
[MI_EVWKHIST].[MI_EVWKHIST_EFFCT_DESC_C] "Effect
Description",
[MI_EVWKHIST].[MI_EVWKHIST_EVENT_DATE_DESC_C] "Event Date
Description",
[MI_EVWKHIST].[MI_EVENT_LNG_DSC_TX] "Event Long
Description",
[MI_EVWKHIST].[MI_EVENT_SHRT_DSC_CHR] "Event Short
Description",
[MI_EVWKHIST].[MI_EVENT_STRT_DT] "Event Start Date",
[MI_EVWKHIST].[MI_EVWKHIST_STATUS_C] "Event Status",
[MI_EVWKHIST].[MI_EVENT_TYP_CHR] "Event Type",
[MI_EVWKHIST].[MI_EVWKHIST_FAILR_MODE_CD_C] "Failure Mode
Code",
[MI_EVWKHIST].[MI_EVWKHIST_FAILR_MODE_DESC_C] "Failure
Mode Description",
[MI_EVWKHIST].[MI_EVWKHIST_FAILURE_REM_T] "Failure
Remarks",
[MI_EVWKHIST].[MI_EVWKHIST_FNCTNL_LOSS_CD_C] "Functional
Loss Code",
[MI_EVWKHIST].[MI_EVWKHIST_FNCTNL_LOSS_DESC_C] "Functional
Loss Description",
[MI_EVWKHIST].[MI_EVWKHIST_MAINT_COMPL_D] "Maintenance
Completion Date",
[MI_EVWKHIST].[MI_EVWKHIST_MAINT_CST_UOM_C] "Maintenance
Cost UOM",
[MI_EVWKHIST].[MI_EVWKHIST_MAINT_CST_N] "Maintenance
Cost",
[MI_EVWKHIST].[MI_EVWKHIST_MAINT_START_D] "Maintenance
Start Date",
[MI_EVWKHIST].[MI_EVWKHIST_MECH_DWN_TIME_N] "Mechanical
Down Time",
```

Available Date", [MI_EVWKHIST].[MI_EVWKHIST_MECH_AVAIL_D] "Mechanically
 Unavailable Date", [MI_EVWKHIST].[MI_EVWKHIST_MECH_UNAVL_D] "Mechanically
 Date", [MI_EVWKHIST].[MI_EVWKHIST_ORDR_CRT_DT_D] "Order Creation
 Description", [MI_EVWKHIST].[MI_EVWKHIST_ORDR_DESC_C] "Order
 Maintenance Plan", [MI_EVWKHIST].[MI_EVWKHIST_ORDR_ID_C] "Order ID",
 Priority Description", [MI_EVWKHIST].[MI_EVWKHIST_ORDR_MAINT_PLAN_C] "Order
 Priority Description", [MI_EVWKHIST].[MI_EVWKHIST_ORDR_PRTY_DESC_C] "Order
 Date", [MI_EVWKHIST].[MI_EVWKHIST_ORDR_PRTY_C] "Order Priority",
 System Condition Desc", [MI_EVWKHIST].[MI_EVWKHIST_ORDR_REF_DT_D] "Order Reference
 Condition", [MI_EVWKHIST].[MI_EVWKHIST_ORDR_SYS_CND_DESC_C] "Order
 Status", [MI_EVWKHIST].[MI_EVWKHIST_ORDR_SYS_COND_C] "Order System
 Code", [MI_EVWKHIST].[MI_EVWKHIST_ORDR_SYS_STAT_C] "Order System
 Description", [MI_EVWKHIST].[MI_EVWKHIST_ORDR_TYP_CD_C] "Order Type
 Status", [MI_EVWKHIST].[MI_EVWKHIST_ORDR_TYP_DESC_C] "Order Type
 Description", [MI_EVWKHIST].[MI_EVWKHIST_ORDR_USER_STAT_C] "Order User
 Status", [MI_EVWKHIST].[MI_EVWKHIST_PM_NBR_C] "PM Number",
 Creation Date", [MI_EVWKHIST].[MI_EVWKHIST_PRDN_CST_N] "Production Cost",
 Description", [MI_EVWKHIST].[MI_EVWKHIST_RQST_ID_C] "Request ID",
 Priority Description", [MI_EVWKHIST].[MI_EVWKHIST_RQST_CRT_DT_D] "Request
 Priority", [MI_EVWKHIST].[MI_EVWKHIST_RQST_DESC_C] "Request
 System Status", [MI_EVWKHIST].[MI_EVWKHIST_RQST_PRTY_DESC_C] "Request
 Code", [MI_EVWKHIST].[MI_EVWKHIST_RQST_PRTY_C] "Request
 Description", [MI_EVWKHIST].[MI_EVWKHIST_RQST_SYS_STAT_C] "Request
 Status", [MI_EVWKHIST].[MI_EVWKHIST_RQST_TYP_CD_C] "Request Type
 Completion Date", [MI_EVWKHIST].[MI_EVWKHIST_RQST_TYP_DESC_C] "Request Type
 Date", [MI_EVWKHIST].[MI_EVWKHIST_RQST_USER_STAT_C] "Request User
 Completion Date", [MI_EVWKHIST].[MI_EVWKHIST_SCHED_COMPL_D] "Scheduled
 Date", [MI_EVWKHIST].[MI_EVWKHIST_SCHED_START_D] "Scheduled Start
 Completion Date", [MI_EVWKHIST].[MI_EVWKHIST_TARGET_COMPL_D] "Target
 Date", [MI_EVWKHIST].[MI_EVWKHIST_TARGET_START_D] "Target Start
 (TTR)", [MI_EVWKHIST].[MI_EVWKHIST_TIME_TO_REPR_N] "Time To Repair
 Type", [MI_EVWKHIST].[MI_EVWKHIST_TOTL_CST_N] "Total Cost",
 [MI_EVWKHIST].[MI_EVWKHIST_WORK_HIST_TYPE_C] "Work History
 [MI_EVWKHIST].[MI_EVWKHIST_WO_PRIORITY_N] "Work Order

```

Priority",
      'WHD_Customer WHD ID' "WHD_Customer WHD ID", [MI_DTWKHIST].
[MI_DTWKHIST_EVNT_DTL_ID_C]
      "WHD_Work History Detail ID", [MI_DTWKHIST].
[MI_DTWKHIST_EVNT_DTL_DESC_C]
      "WHD_Work Hist Detail Desc", [MI_DTWKHIST].
[MI_DTWKHIST_ORDR_ID_C]
      "WHD_Order ID", [MI_DTWKHIST].[MI_DTWKHIST_RQST_ID_C]
"WHD_Request ID",
      [MI_DTWKHIST].[MI_DTWKHIST_CAUSE_CD_C] "WHD_Cause Code",
      [MI_DTWKHIST].[MI_DTWKHIST_CAUSE_DESC_C] "WHD_Cause
Description",
      [MI_DTWKHIST].[MI_DTWKHIST_CNDDTN_CD_C] "WHD_Condition
Code",
      [MI_DTWKHIST].[MI_DTWKHIST_CNDDTN_DESC_C] "WHD_Condition
Description",
      [MI_DTWKHIST].[MI_DTWKHIST_DTL_NARTV_T] "WHD_Detail
Narrative",
      [MI_DTWKHIST].[MI_DTWKHIST_MAINT_ITEM_CD_C]
"WHD_Maintainable Item Code",
      [MI_DTWKHIST].[MI_DTWKHIST_MAINT_ITEM_DESC_C]
"WHD_Maintainable Item Desc",
      [MI_DTWKHIST].[MI_DTWKHIST_MAINT_ACTN_CD_C]
"WHD_Maintenance Action Code",
      [MI_DTWKHIST].[MI_DTWKHIST_MAINT_ACTN_DESC_C]
"WHD_Maintenance Action Desc"
      FROM [MI_EVWKHIST] JOIN_PRED [MI_EQUIP000] JOIN_PRED
[MI_FNCLOC00]
      ON {MIR_FLHSEQ} ON {MIR_HSWKHST} JOIN_SUCC [MI_DTWKHIST]
ON {MIR_EVNTDET}

```

About the Work History Data Loader Workbook Layout and Use

This section provides a high-level overview and explanation of how the data loader workbook is constructed.

To import data using the Work History Data Loader, APM provides an Excel workbook, `Work History.xlsx`, which supports baseline data loading of work history and work history detail records in APM. This workbook must be used to perform the data load.

Note: Worksheets in the workbook not being used may be left blank, but should not be deleted from the workbook.

The following table lists the worksheets that are included in the Foundation Work History Data Loader workbook.

Worksheet	Description
Configuration	The Configuration worksheet is needed to describe the type of data that you will be loading and how that data should be handled during the data load.
WorkHistory	This worksheet is used to specify data for import to the Work History family.
WorkHistoryToWHDDetails	This worksheet is used to specify data for import to the Work History Detail family.

Worksheet	Description
WorkHistoryToEquipment	This worksheet is used to link Work History to Equipment records.
WorkHistoryToFLOCs	This worksheet is used to link Work History to Functional Location records.

Configuration Worksheet

The **Configuration** worksheet tells the Data Loader what types of data are being loaded and how the data is to be loaded, and is standard for all data loads regardless of the type of data that you are loading. The following table outlines the options that are valid or the values that are expected in each of the columns on the **Configuration** worksheet

Field Caption	Field ID	Data Type (Length)	Comments
Number of Rows to Chunk	OPTION_NUMBER_ROWS_TO_CHUNK	Character	Option to break-up or chunk data.
Load Data From Worksheet	LOAD_DATA_WORKSHEET	Boolean	Identifies if data from the corresponding worksheet identified in the Data Worksheet ID column will be loaded or not. <ul style="list-style-type: none"> • True: The corresponding worksheet will be processed. • False: The corresponding worksheet will not be processed.
Data Worksheet ID	DATA_WORKSHEET_ID	Character	This column contains the name of the <data> worksheet where the actual data is located. It needs to have the same name as the <data> worksheet in the data loader workbook.

Field Caption	Field ID	Data Type (Length)	Comments
Batch Size	BATCH_SIZE	Character	<p>Modifying this field is required to determine the number of records processed in each batch. Enter the batch size you want, and the Data Loader will process that many records per batch.</p> <p>For example, if you want to use a batch size of 100, enter 100, and the data loader will process 100 records per batch.</p> <p>Note: The recommended batch size is 100. If the Batch Size column is removed from the source workbook, the data loader will default to a batch size of 100.</p> <p>In addition to processing the data in batches, the log file reports progress by batch.</p>
Primary Family ID	PRIMARY_FAMILY_ID	Character	<p>Depending on the type of data that you are working with, this will contain the Relationship Family ID or the Entity Family ID. You can also allow the data in source file to determine the Family ID by encapsulating the Field ID that contains the Family ID data in brackets (<>).</p> <p>For example, if in the <data> worksheet there is a column with an ID of PRIMARY_FAMILY_ID, where each row contains the corresponding Family ID, then in this column you should put the value of <PRIMARY_FAMILY_ID>.</p> <p>If the Family ID in the Meridium, Inc. metadata contains spaces, then you have to use this feature.</p>

Field Caption	Field ID	Data Type (Length)	Comments
Primary Family Key Fields	PRIMARY_FAMILY_KEY_FIELDS	Character	<p>This column contains the Field IDs associated with the Primary Family that are used to uniquely identify a record. If more than one field is to be used, then each Field ID needs to be separated by a (Pipe) character. In the case where you are loading data into a relationship, if no keys fields exist or are used, use the <none> constant.</p> <p>If the Primary Action is ACTION_INSERTONLY, then no key fields need to be specified, so you can use the <none> constant.</p>
Family Type	FAMILY_TYPE	Character	The value in this column should be Entity or Relationship depending on the type of data that is being loaded.
Predecessor Family ID	PRED_FAMILY_ID	Character	When the Family Type is Relationship, this column will contain the value of the Entity Family ID that is the predecessor in the relationship. Otherwise, it should contain the <none> constant. You can also use the data in each of the rows to determine the Predecessor Family ID.
Predecessor Family Key Fields	PRED_FAMILY_KEY_FIELDS	Character	<p>This column contains the Field ID or IDs associated with the Predecessor Family that are used to uniquely identify the predecessor record. If more than one field is to be used, then each Field ID needs to be separated by a (Pipe) character.</p> <p>If the Predecessor Action is ACTION_INSERTONLY, then no key fields need to be specified, so you can use the <none> constant.</p>
Successor Family ID	SUCC_FAMILY_ID	Character	When the Family Type is Relationship, this column will contain the value of the Entity Family ID that is the successor in the relationship. Otherwise, it should contain the <none> constant. You can also use the data in each of the rows to determine the Successor Family ID.

Field Caption	Field ID	Data Type (Length)	Comments
Successor Family Key Fields	SUCC_FAMILY_KEY_FIELDS	Character	<p>This column contains the Field ID or IDs associated with the Successor Family that are used to uniquely identify the successor record. If more than one field is to be used, then each Field ID needs to be separated by a (Pipe) character.</p> <p>If the Successor Action is ACTION_INSERTONLY, then no key fields need to be specified, so you can use the <none> constant.</p>
Primary Action	PRIMARY_ACTION	Character	<p>The value in this column will determine the action that will be applied to the Primary Family records. If the Family Type is Entity, then the possible values are:</p> <ul style="list-style-type: none"> • ACTION_INSERTONLY • ACTION_INSERTUPDATE • ACTION_UPDATEONLY • ACTION_DELETE • ACTION_PURGE <p>Deleting a record and purging a record will both delete the current record, the difference being that the purge action will delete the record and all of the links or relationships tied to that record. The delete action will simply attempt to delete the record, and if it is related to another record, the delete will fail. If The Family Type is Relationship, then the possible values are:</p> <ul style="list-style-type: none"> • ACTION_INSERTONLY • ACTION_INSERTUPDATE • ACTION_UPDATEONLY • ACTION_DELETE

Field Caption	Field ID	Data Type (Length)	Comments
Predecessor Action	PRED_ACTION	Character	<p>The value in this column will determine the action that will be applied to the Predecessor Family records. The possible values are:</p> <ul style="list-style-type: none"> • ACTION_INSERTONLY • ACTION_INSERTUPDATE • ACTION_UPDATEONLY • ACTION_DELETE • ACTION_PURGE • ACTION_LOCATE <p>If The Family Type is Entity, then the values need to be</p> <ul style="list-style-type: none"> • ACTION_NONE
Successor Action	SUCC_ACTION	Character	<p>The value in this column will determine the action that will be applied to the Successor Family records. The possible values are:</p> <ul style="list-style-type: none"> • ACTION_INSERTONLY • ACTION_INSERTUPDATE • ACTION_UPDATEONLY • ACTION_DELETE • ACTION_PURGE • ACTION_LOCATE <p>If The Family Type is Entity, then the values need to be</p> <ul style="list-style-type: none"> • ACTION_NONE
Insert with Null Values?	OPTION_INSERT_ON_NULL	Boolean	When setting field values on a new record, if a value coming across is NULL, the field values will be set to NULL if this option is set to True.
Update with Null Values?	OPTION_UPDATE_ON_NULL	Boolean	When setting field values on an existing record, if a value coming across is NULL, the field values will be set to NULL if this option is set to True.

Field Caption	Field ID	Data Type (Length)	Comments
Replace an Existing Link?	OPTION_REPLACE_EXISTING_LINK	Boolean	<p>The Replace Existing Relationship option is used to determine how a relationship is to be maintained by its cardinality definition.</p> <p>For example, the relationship Location Contains Asset that is defined in the Configuration Manager. It has a cardinality defined as Zero or One to Zero or One, has a Location LP-2300, and contains the Asset P-2300. If, in the data load, you assign the Asset P-5000 to be contained in the Location LP-2300, and you have set the Replace Existing Link property to True, then the data loader will link P-5000 to LP-2300 and unlink P-2300 from LP-2300. This assumes that P-5000 is not currently linked to another location. The same is true for a relationship that is defined as Zero or One to Zero or Many, or Zero or Many to Zero or One.</p>
Allow Change of Family?	OPTION_ALLOW_CHANGE_OF_FAMILY	Boolean	<p>Allows the data loader to move an entity from one family to another.</p> <p>For example, this would allow an entity that is currently assigned to the Centrifugal Pump family to be moved to the Reciprocating Pump family.</p> <p>All relationships will be maintained as long as the family to which the entity is being moved allows the same relationships.</p> <p>Note: Because of the extra processing required, by selecting this option, the interface performance will decrease.</p>

WorkHistory

Field ID	Filed Caption	Data Type (Length)	Comments
Event ID	MI_EVENT_ID	Character (255)	Generated by the system, and is not loaded.
CMMS System	MI_EVWKHIST_SAP_SYSTEM_C	Character (50)	None
Equipment ID	MI_EVENT_ASST_ID_CHR	Character (255)	Used as unique key to find equipment.
Asset Tech ID	MI_EVWKHIST_ASST_TECH_ID_C	Character (255)	None
Location ID	MI_EVENT_LOC_ID_CHR	Character (255)	Is a key field, and is used to find Functional Location.
Activity Cause	MI_EVWKHIST_ACTIV_CAUSE_C	Character (255)	None
Activity Cause Description	MI_EVWKHIST_ACTIV_CAUSE_DESC_C	Character (255)	None
Activity Type	MI_EVWKHIST_ORDR_PM_ACT_C	Character (50)	None
Activity Type Description	MI_EVWKHIST_ORDR_PM_ACT_DESC_C	Character (255)	None
Breakdown Indicator	MI_EVWKHIST_BRKDN_IND_F	Boolean	None
Detection Method Code	MI_EVWKHIST_DETCT_MTHD_CD_C	Character (50)	None
Detection Method Description	MI_EVWKHIST_DETCT_MTHD_DESC_C	Character (255)	None
Effect Code	MI_EVWKHIST_EFFCT_CD_C	Character (50)	None
Effect Description	MI_EVWKHIST_EFFCT_DESC_C	Character (50)	None
Event Date Description	MI_EVWKHIST_EVENT_DATE_DESC_C	Character (255)	None
Event Long Description	MI_EVENT_LNG_DSC_TX	Text	None
Event Short Description	MI_EVENT_SHRT_DSC_CHR	Character (255)	None
Event Start Date	MI_EVENT_STRT_DT	Date	None
Event Status	MI_EVWKHIST_STATUS_C	Character (50)	None
Event Type	MI_EVENT_TYP_CHR	Character (255)	None
Failure Mode Code	MI_EVWKHIST_FAILR_MODE_CD_C	Character (50)	None

Field ID	Filed Caption	Data Type (Length)	Comments
Failure Mode Description	MI_EVWKHIST_FAILR_MODE_DESC_C	Character (255)	None
Failure Remarks	MI_EVWKHIST_FAILURE_REM_T	Text	None
Functional Loss Code	MI_EVWKHIST_FNCTNL_LOSS_CD_C	Character (50)	None
Functional Loss Description	MI_EVWKHIST_FNCTNL_LOSS_DESC_C	Character (50)	None
Maintenance Completion Date	MI_EVWKHIST_MAINT_COMPL_D	Date	None
Maintenance Cost UOM	MI_EVWKHIST_MAINT_CST_UOM_C	Character (10)	None
Maintenance Cost	MI_EVWKHIST_MAINT_CST_N	Numeric	None
Maintenance Start Date	MI_EVWKHIST_MAINT_START_D	Date	None
Mechanical Down Time	MI_EVWKHIST_MECH_DWN_TIME_N	Numeric	Calculated by system.
Mechanically Available Date	MI_EVWKHIST_MECH_AVAIL_D	Date	None
Mechanically Unavailable Date	MI_EVWKHIST_MECH_UNAVL_D	Date	None
Order Creation Date	MI_EVWKHIST_ORDR_CRT_DT_D	Date	None
Order Description	MI_EVWKHIST_ORDR_DESC_C	Character (255)	None
Order ID	MI_EVWKHIST_ORDR_ID_C	Character (50)	None
Order Maintenance Plan	MI_EVWKHIST_ORDR_MAINT_PLAN_C	Character (50)	None
Order Priority	MI_EVWKHIST_ORDR_PRTY_C	Character (50)	None
Order Priority Description	MI_EVWKHIST_ORDR_PRTY_DESC_C	Character (255)	None
Order Reference Date	MI_EVWKHIST_ORDR_REF_DT_D	Date	None
Order System Condition	MI_EVWKHIST_ORDR_SYS_COND_C	Character (50)	None
Order System Condition Description	MI_EVWKHIST_ORDR_SYS_CND_DESC_C	Character (255)	None
Order System Status	MI_EVWKHIST_ORDR_SYS_STAT_C	Character (255)	None
Order Type Code	MI_EVWKHIST_ORDR_TYP_CD_C	Character (50)	None
Order Type Description	MI_EVWKHIST_ORDR_TYP_DESC_C	Character (50)	None

Field ID	Filed Caption	Data Type (Length)	Comments
Order User Status	MI_EVWKHIST_ORDR_USER_STAT_C	Character (255)	None
PM Number	MI_EVWKHIST_PM_NBR_C	Character (255)	None
Production Cost	MI_EVWKHIST_PRDN_CST_N	Numeric	None
Request ID	MI_EVWKHIST_RQST_ID_C	Character (50)	None
Request Creation Date	MI_EVWKHIST_RQST_CRT_DT_D	Date	None
Request Description	MI_EVWKHIST_RQST_DESC_C	Character (255)	None
Request Priority	MI_EVWKHIST_RQST_PRTY_C	Character (50)	None
Request Priority Description	MI_EVWKHIST_RQST_PRTY_DESC_C	Character (255)	None
Request System Status	MI_EVWKHIST_RQST_SYS_STAT_C	Character (255)	None
Request Type Code	MI_EVWKHIST_RQST_TYP_CD_C	Character (50)	None
Request Type Description	MI_EVWKHIST_RQST_TYP_DESC_C	Character (255)	None
Request User Status	MI_EVWKHIST_RQST_USER_STAT_C	Character (255)	None
Scheduled Completion Date	MI_EVWKHIST_SCHED_COMPL_D	Date	None
Scheduled Start Date	MI_EVWKHIST_SCHED_START_D	Date	None
Target Completion Date	MI_EVWKHIST_TARGET_COMPL_D	Date	None
Target Start Date	MI_EVWKHIST_TARGET_START_D	Date	None
Work History Type	MI_EVWKHIST_WORK_HIST_TYPE_C	Character (50)	None
Work Order Priority	MI_EVWKHIST_WO_PRIORITY_N	Numeric	None
Site Reference Name	MI_SITE_NAME	Character (50)	None

WorkHistoryToWHDDetails Worksheet

On the WorkHistoryToWHDDetails worksheet, you will find work history and work history detail fields.

Note: Each row in this worksheet represents a unique record. You should not include the same asset more than once.

Field ID	Field Caption	Data Type (Length)	Comments
Event ID	MI_EVWKHIST MI_EVENT_ID	Character (255)	Generated by the system, and is not loaded.
CMMS System	MI_EVWKHIST MI_EVWKHIST_SAP_SYSTEM_C	Character (50)	None
Work Detail History ID	MI_DTWKHIST MI_DTWKHIST_EVNT_DTL_ID_C	Character (50)	None
CMMS System	'MI_DTWKHIST MI_DTWKHIST_SAP_SYSTEM_C	Character (50)	None
Work History ID	MI_DTWKHIST MI_DTWKHIST_WRK_HISTRY_ID_C	Character (50)	None
Work History Detail Description	MI_DTWKHIST MI_DTWKHIST_EVNT_DTL_DESC_C	Character (255)	None
Order ID	MI_DTWKHIST MI_DTWKHIST_ORDR_ID_C	Character (50)	None
Request ID	MI_DTWKHIST MI_DTWKHIST_RQST_ID_C	Character (50)	Request ID from the associated order ID on the WH record, if not work order.
Cause Code	MI_DTWKHIST MI_DTWKHIST_CAUSE_CD_C	Character (50)	None
Cause Description	'MI_DTWKHIST MI_DTWKHIST_CAUSE_DESC_C	Character (255)	None
Condition Code	MI_DTWKHIST MI_DTWKHIST_CNDTN_CD_C	Character (20)	None
Condition Description	MI_DTWKHIST MI_DTWKHIST_CNDTN_DESC_C	Character (255)	None
Detail Narrative	MI_DTWKHIST MI_DTWKHIST_DTL_NARTV_T	Text	None
Maintainable Item Code	MI_DTWKHIST MI_DTWKHIST_MAINT_ITEM_CD_C	Character (50)	None
Maintainable Item Description	MI_DTWKHIST MI_DTWKHIST_MAINT_ITEM_DESC_C	Character (255)	None
Maintenance Action Code	MI_DTWKHIST MI_DTWKHIST_MAINT_ACTN_CD_C	Character (50)	None
Maintenance Action Description	MI_DTWKHIST MI_DTWKHIST_MAINT_ACTN_DESC_C	Character (255)	None

Field ID	Field Caption	Data Type (Length)	Comments
Equipment ID	MI_DTWKHIST MI_DTWKHIST_ASST_ID_C	Character (50)	None
Functional Location ID	MI_DTWKHIST MI_DTWKHIST_LOC_ID_C	Character (50)	None
Site Reference Name	MI_DTWKHIST MI_SITE_NAME	Character (50)	None
Sub Object Number	MI_DTWKHIST MI_DTWKHIST_SUB_OBJECT_NUM_C	Character (50)	None.

WorkHistoryToEquipment Worksheet

Field ID	Filed Caption	Data Type (Length)	Comments
Event ID	MI_EVWKHIST MI_EVENT_ID	Character (255)	None
CMMS System	'MI_EVWKHIST MI_EVWKHIST_SAP_SYSTEM_C	Character (50)	None
Equipment ID	'MI_EQUIP000 MI_EQUIP000_EQUIP_ID_C	Character (50)	None
CMMS System	'MI_EQUIP000 MI_EQUIP000_SAP_SYSTEM_C	Character (50)	None

WorkHistoryToFLOCs Worksheet

Field ID	Filed Caption	Data Type (Length)	Comments
Event ID	MI_EVWKHIST MI_EVENT_ID	Character (255)	None
CMMS System	'MI_EVWKHIST MI_EVWKHIST_SAP_SYSTEM_C	Character (50)	None
Functional Location Internal	'MI_FNCLOC00 MI_FNCLOC00_INTERNAL_ID_C	Character (50)	None
CMMS System	'MI_FNCLOC00 MI_FNCLOC00_SAP_SYSTEM_C	Character (50)	None

APM Connect Data Loader Logs

About APM Connect Data Loader Logs

The APM Connect Data Loader log contains detailed information about the data loader jobs, such as error messages, warnings, and general information on the records that were loaded. The log files for the data loader jobs are available for download in the **Data Loaders** page. This page also provides information about the status of the Data Loader jobs that have been run by the APM Connect Data Loader feature.

Access the Data Loaders Page

Procedure

In the module navigation menu, select **Tools > Data Loaders**.

The **Data Loaders** page appears, displaying the list of the Data Load jobs that are running or complete. You can use this page to download the Data Loader Templates and import data through the Data Loader user Interface. For more information on the columns available in this page, refer to the [Field Descriptions of the Data Loaders Page](#) on page 110 topic.

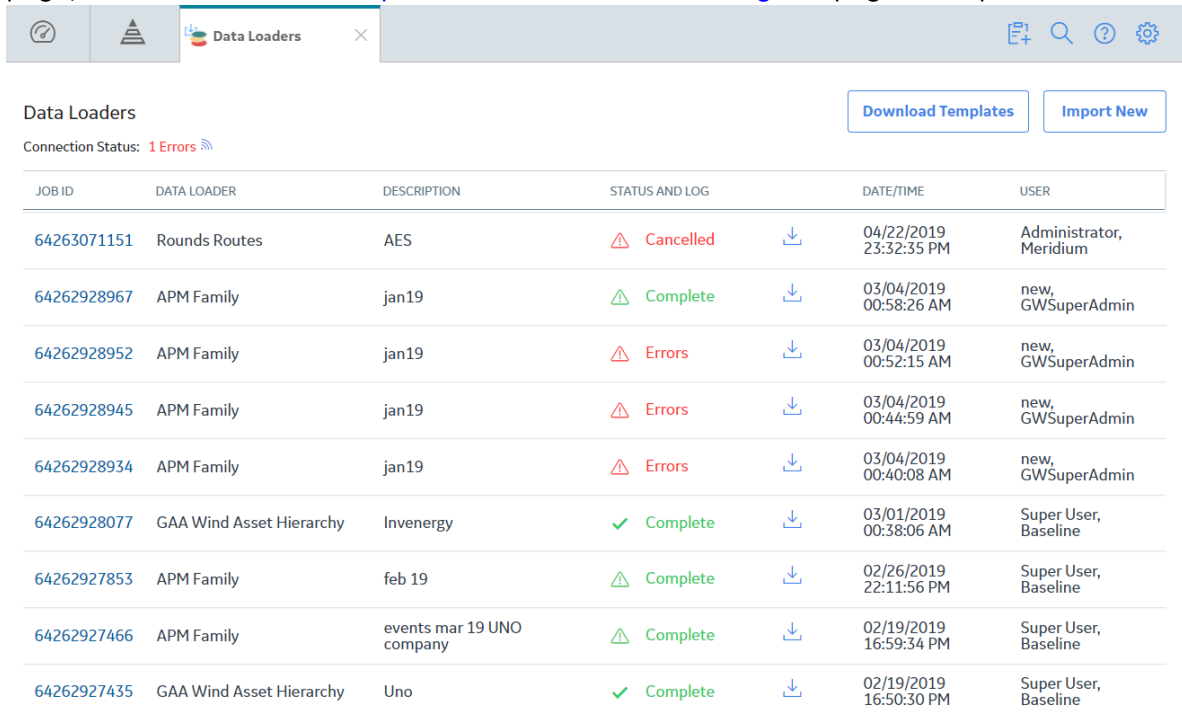

JOB ID	DATA LOADER	DESCRIPTION	STATUS AND LOG	DATE/TIME	USER
64263071151	Rounds Routes	AES	Cancelled	04/22/2019 23:32:35 PM	Administrator, Meridium
64262928967	APM Family	jan19	Complete	03/04/2019 00:58:26 AM	new, GWSuperAdmin
64262928952	APM Family	jan19	Errors	03/04/2019 00:52:15 AM	new, GWSuperAdmin
64262928945	APM Family	jan19	Errors	03/04/2019 00:44:59 AM	new, GWSuperAdmin
64262928934	APM Family	jan19	Errors	03/04/2019 00:40:08 AM	new, GWSuperAdmin
64262928077	GAA Wind Asset Hierarchy	Invenergy	Complete	03/01/2019 00:38:06 AM	Super User, Baseline
64262927853	APM Family	feb 19	Complete	02/26/2019 22:11:56 PM	Super User, Baseline
64262927466	APM Family	events mar 19 UNO company	Complete	02/19/2019 16:59:34 PM	Super User, Baseline
64262927435	GAA Wind Asset Hierarchy	Uno	Complete	02/19/2019 16:50:30 PM	Super User, Baseline

Cancel a Data Load Job

About This Task

There are occasions when you may want to stop a data load job. For example, if you inadvertently selected an incorrect template to run, you need to stop the data load job. You can cancel the import jobs from the **Data Loaders** page in APM.



Procedure

1. In the module navigation menu, select **Tools > Data Loaders**.
The **Data Loaders** page appears, displaying the list of the data load jobs that are running or complete.
2. Identify the job record that is an active status that you want to cancel.
3. In the **Status and Log** column of the job record that you want to cancel, select .
The job is cancelled and the status of the job is changed to **Cancelled by User**.

Note: If you cancel a job, any changes that are already done are not removed. Therefore, you may need to manually modify records to update or remove unnecessary data.

Log Statuses

The **Status and Log** column in the **Data Loaders** page displays the status of the various Data Loader jobs that have run in the APM system. The following table contains the list of available statuses with description.

Status	Description
Cancelled by User	The data import job was cancelled successfully. Note: When a job is cancelled, the data imported prior to cancelling is not removed.
Complete	The data has been imported successfully into APM. Note: if the  icon appears with the Complete status, the data was imported with warnings. You can download the log file to view the detailed warning messages.
Configuring Dataloader	The data import job is configuring the user roles and arranging the data processing for most efficient execution flow.
Data Synchronization in Progress	The data import job is synchronizing the loaded data and relationships across the Data Source.
Dataloader Enqueued	The maximum number of data load jobs, as defined in the APM Connect Connection Records , has been exceeded, or there is a job of the same type running. The data import will begin after the other jobs are complete.
Errors	The data import is complete but encountered one or more errors. You can download the log file to view detailed error messages.
In Progress	The data import job is loading data into the APM Data Source.
Job Cancelling	The data import job is in the process of being canceled. This occurs after you select  .
Staging Complete	The data import job was prepared successfully.
Staging Failure	The data import job failed during preparation.
Staging In Progress	The data import job is being prepared on the APM Connect Server.
Waiting	Initial state when a job is created. The data import job is queued for pre-processing on the APM Connect Server.

Field Descriptions of the Data Loaders Page

The following table provides you list of fields that are available in the **Data Loaders** page.

Field	Data Type	Description	Behavior and Usage
Job ID	Hyperlink	The Job ID of the Integration Log Record.	You can select the hyperlink to view the details of the specific Interface Log Record in a new tab.
Data Loader	Text	The Description of the APM Connect Job related to the record.	Populated automatically based on the type of Data Loader that was selected.
Description	Text	The text that was entered in the Job Description box by the user.	Populated automatically with the text that was entered in the Job Description box when importing the data.
Status and Log	N/A	Provides status of the Interface job and a link to download the Integration Log File.	<p>The status is a Red or Green icon indicating the status, success or failure of the job.</p> <p>You can select the Download () button to download the Integration Log file for the scheduled tasks that are completed and are in Successful or Failed state.</p> <p>Note: This log contains detailed information about the job such as error messages, warnings concerning the data load, and general information about the records that were loaded.</p>
Date/Time	Date	The time at which the Integration job was completed.	Populated automatically based on the time when the job was completed.
User	Text	The user name of the person or System User who initiated the job in APM.	Populated automatically indicating the name of user who ran the job.

Note: The log screen is set to refresh at an interval. If you want to view the log records from older records, it is recommended to query the Interface log family [MI_INFCLOG].

Chapter 6

Automatic Data Loader

Topics:

- [About the Automatic Data Loader Job](#)

About the Automatic Data Loader Job

The Automatic Data Loader can load `.xlsx` files created with Microsoft Excel version 2007 and above or `.zip` files into the system from an on-premises installation of APM Connect.

Note: To be able to load data successfully using Automatic Data Loader, make sure that:

- The file name length is not more than 100 characters.
- The file path of the scan directory is not more than 150 characters from root.
- The file name does not contain any special characters.
- Data loader templates are followed for loading the data in excel files.

APM provides a method to automatically load data into the system from correctly formatted `.xlsx` or a `.zip` file containing correctly formatted `.csv` files. You must place your data loader workbook in the correct directory for a successful data load.

The job monitors a configured load directory for the presence of a file in a subdirectory and stages the contents of the file into the system. Multiple files moved into the directory are processed in descending order according to the last modified time stamp on each file.

The system logs the staging progress and archives the files in an archive directory. If data fails to stage or upload, a message is written to the log indicating the reason for failure, and the source files are moved to the FAILED FILES directory.

A service then retrieves the staged workbooks, and, using an administrative account, the service invokes the appropriate data loader to load the data contained in the workbooks.

Chapter 7

EAM Adapter

Topics:

- [EAM Adapters](#)
- [System Architecture for EAM Adapter](#)

EAM Adapters

You can use EAM Adapters to ingest data into APM using one of the following EAM Adapters:

- [Maximo Adapters](#)
- [SAP Adapters](#)

System Architecture for EAM Adapter

Single Server Configuration (Recommended)

The single server configuration is the simplest way to configure APM Connect. However, it does include an embedded database. The following image depicts this configuration.

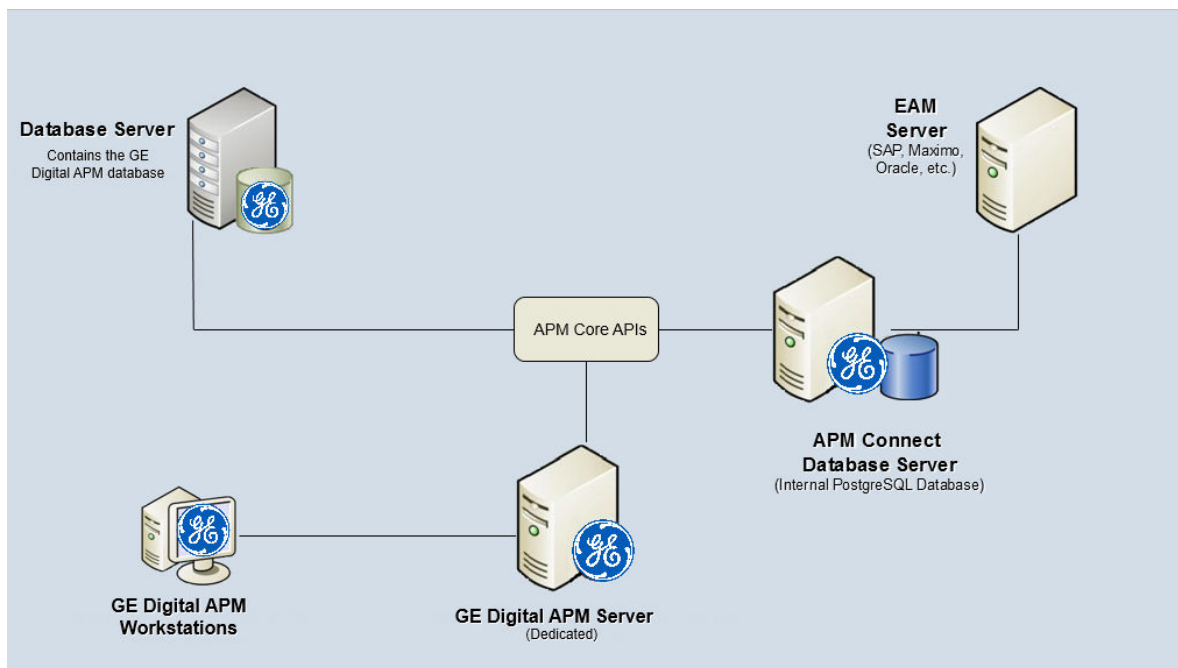

External Database Configuration

Many organizations choose to separate their databases. It is possible to install the intermediate repository database on an external server, and to keep the APM Connect Systems database on a different server. The following image depicts this configuration.

Note: The external configuration will affect performance. The single server configuration results in faster performance.

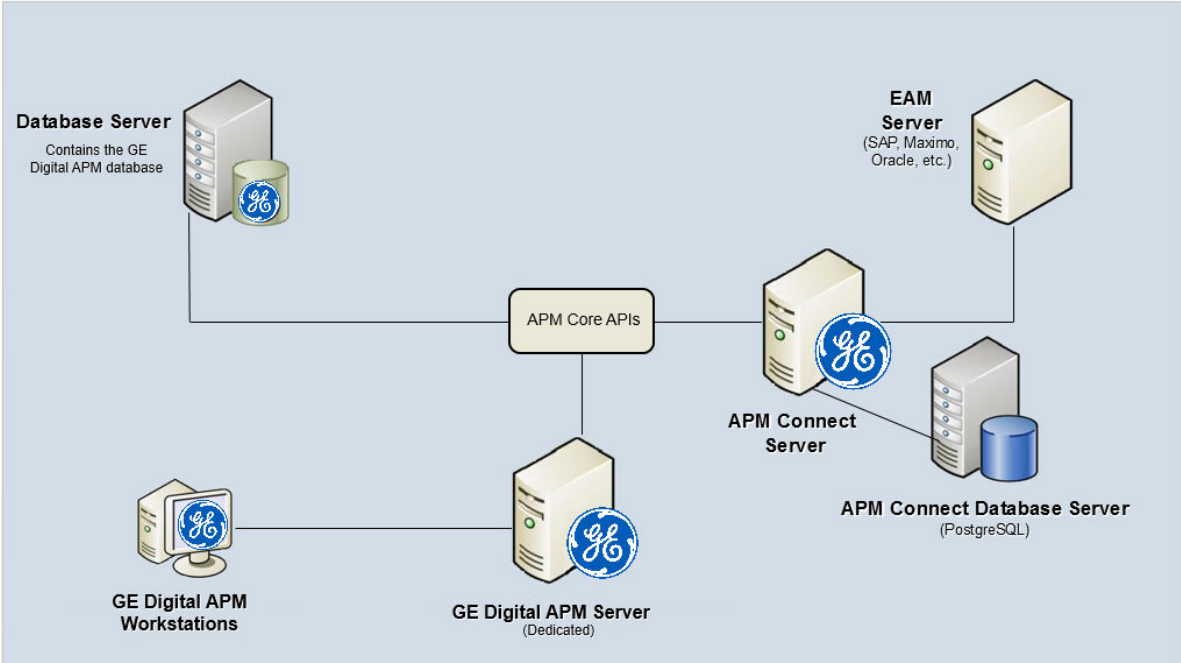

Chapter 8

General Reference

Topics:

- [APM Connect Version Compatibility Table](#)
- [The Automatic Data Loader Directories](#)
- [About Time Zone Data](#)
- [Support for Multiple Source Systems](#)
- [Support for Multiple Culture Settings from a Single Source System](#)

APM Connect Version Compatibility Table

This topic provides the installation files that are required for an APM Connect installation, and the version structure for APM Connect.

Version Structure

Example:	EAM	SAP	V1	5	2
Description:	Area of APM Connect (that is, Data Loaders, EAM, M2M)	EAM System released against (that is, SAP, SAP PI, Maximo)	Architecture Release	Major Release	Maintenance or Patch Release

The following are examples of how to interpret the versions.

- EAM SAP V1.5.0 is the fifth major release on the APM Connect V1.x architecture; it can be applied to the EAM system SAP.
- EAM SAP V1.5.1 is a maintenance release that can be applied to EAM SAP V1.5.0.
- DL V1.4.0 is the fourth major release on the APM Connect V1.x architecture.

APM Compatibility Table

This table includes only the APM versions for which a corresponding APM Connect version was released.

Table 3: APM Compatibility Matrix

APM Framework Version	APM Connect Base	Integrated Pack Version	SAP ABAP Version
V4.6.x	APM Connect Services V5.1.2.0.0	Integration Pack (IP-Release_5_1_2)	V7.X
V4.5.0.0.0	APM Connect Base V2.0.0	UDLP Version: UDLP V2.9.0 or V2.8.0 or v2.9.0.1 (with ABAP V7.X)	V4.X

Table 4: SAP ABAP Package Certification Matrix

SAP Certificate Number	Certificate Issue Date	Certificate Expiration Date	SAP Version	ABAP Interface Version (as displayed on the certificate)	APM Versions
16649	June 26, 2020	June 25, 2023	S4/HANA 1909	V4.X	4.4.x, 4.5.x, 4.6.x, (UDLP 3.3.0)
13857	October 6, 2020	October 5, 2023	ERP (ECC) 6 EHP8	V7.X	4.6.x, 5.x

SAP Certificate Number	Certificate Issue Date	Certificate Expiration Date	SAP Version	ABAP Interface Version (as displayed on the certificate)	APM Versions
16864	January 21, 2021	January 20, 2024	S4/HANA Cloud Extended Edition 1909	V7.X	4.5.x*, 4.6.x, 5.x
17051	January 21, 2021	January 20, 2024	S4/HANA 1909	V7.X	4.5.x*, 4.6.x, 5.x
17336	January 21, 2021	January 20, 2024	S4/HANA Cloud Extended Edition 2020	V7.X	4.5.x*, 4.6.x, 5.x
17337	January 21, 2021	January 20, 2024	S4/HANA 2020	V7.X	4.5.x*, 4.6.x, 5.x
20873	October 12, 2022	October 11, 2025	S4/HANA Cloud Extended Edition 2021	V7.X	4.5.x*, 4.6.x, 5.x
20874	October 12, 2022	October 11, 2025	S4/HANA 2021	V7.X	4.5.x*, 4.6.x, 5.x
21395	July 20, 2023	July 20, 2026	S4/HANA 2022	V7.X	4.5.x*, 4.6.x, 5.x
24053, 24054	Nov 05, 2024	Nov 05, 2027	S4/HANA 2023	V7.X	4.6.x, 5.x

Note: *You must have UDLP 2.9.0.1 or later to use APM V4.5.0.0.0 with SAP ABAP packages of certificate numbers 16864, 17051, 17336, 17337, 20873, 20874, and 21395.

The Automatic Data Loader Directories

The automatic data loader job uses directories within the directory identified in the SCAN_DIR parameter to identify the data loader to use for a particular workbook.

Data Loaders and Directories

The following table lists the directories that are created when the job starts that correspond to the various data loaders.

Data Loader Name	Directory Name
APM Family	ManageAPM
Asset Criticality Analysis (ACA)	ACADataloader
Asset Criticality Analysis (ACA Checklist)	ACAcheckListDataLoader
Asset Ingestion Loader	AssetIngestionLoader
Asset Strategy Management (ASM)	ManageASM
Asset Strategy Management (ASM) Templates	ManageAssetStrategyTemplate
Calibration	Calibration Loader

Data Loader Name	Directory Name
Custom Asset Hierarchy	Custom Asset Hierarchy Loader
Equipment and Functional Location	ManageEquipmentAndFunctional Location
Failure Modes and Effects Analysis (FMEA)	ManageRCMFMEA
Failure Modes and Effects Analysis (FMEA) Analysis Templates	ManageFMEAAnalysisTemplate
Failure Modes and Effects Analysis (FMEA) Asset Templates	ManageFMEAAssetTemplate
Generation Availability Analysis (GAA) Amplification Codes	GAA GADS Amplification Code
Generation Availability Analysis (GAA) Cause Code	GAA GADS Cause Code
Generation Availability Analysis (GAA) Events	GAA Events
GAA Wind Asset Hierarchy	GAA Wind Asset Hierarchy
GAA Wind Events	GAA Wind Events
GAA Wind Sub Group Capacity	GAA Wind Sub Group Capacity
Geographic Information System (GIS)	GISDataLoader
Hazards	Hazards Loader
Inspection Management (IM) Assets	ManageInspections
Inspection Management (IM) Functional Location	ManageInspectionsFL
Production Loss Analysis (PLA) Admin	PLA Admin Data
Production Loss Analysis (PLA) Plan	PLA Plan Data
Production Loss Analysis (PLA) Production Event	Production Event Data
Reliability Centered Maintenance (RCM)	ManageRCM
RCM Analysis Template	ManageRCMAnalysisTemplate
Risk Based Inspection (RBI) 580	ManageRBI580
Risk Based Inspection (RBI) 581	ManageRBI581
Risk Based Inspection (RBI) Corrosion Loop	Load RBI Corrosion Loop
Risk Matrix	RiskMatrixDataLoader
Role	RoleDataLoader
Root Cause Analysis (RCA)	Manage RCA
Rounds Allowable Values	Rounds Allowable Value
Rounds Readings	Rounds Readings

Data Loader Name	Directory Name
Rounds Routes	Rounds Route
Rounds Templates	Rounds MLTG
Tags to Assets Relationship	ManageTagLinks
Taxonomy	ManageTaxonomy
Thickness Monitoring (TM) Equipment	ManageTMLGroup
Thickness Monitoring (TM) Functional Location	ManageTMLGroupFL
Work History	ManageWorkHistory

About Time Zone Data

APM stores the dates and times of transactions in Universal Coordinated Time (UTC) format. This enables the data to flow through the system in a single time zone format. APM Connect supports the time zones defined in [https://docs.microsoft.com/en-us/previous-versions/windows/embedded/gg154758\(v=winembedded.80\)](https://docs.microsoft.com/en-us/previous-versions/windows/embedded/gg154758(v=winembedded.80)).

To provide information with the time stamp relevant to your operations, the system converts UTC to your time zone by using the time zone information configured in your user definition.

Important: If you change the time zone information configured in your user definition, all the records will reflect the new time zone.

The following sections contain the time zone considerations relevant to specific systems.

Maximo

APM stores the time stamp associated with the data extracted from Maximo in UTC and displays the time stamp based on your configured time zone.

SAP

SAP provides a set of baseline time zone codes, which contain most of the standard time zones across the world. SAP also provides the ability for administrators to define their own custom time zone, as needed. Before you use a customized time zone, you must configure the `timezone_control` table in APM Connect to include the customized time zone.

SAP defines two types of time zones:

- **System:** This time zone is based on SAP Application Server Operating System and is derived from the context file. You cannot modify this type of time zone.
- **User:** This time zone is based on the user who created the SAP record. You can modify and store this type of time zone in the SAP user interface.

APM stores the time stamp associated with the data extracted from SAP in UTC and displays the time stamp based on the time zone configured for the user who created the SAP record.

Note: If the data extracted from SAP contains only the date, then APM will assign the time 00:00:00 and adjust the assigned time with the SAP system or user time zone. This may lead to a date mismatch when you choose to display the data in APM. To prevent this, APM stores the assigned reference time stamp as a string within the data, which is hidden by default. If you need this information, you can configure APM to display the data.

Support for Multiple Source Systems

Whether in a cloud environment or an on-premise installation, APM Connect enables you to connect multiple source systems to a single APM system.

There are occasions when you need to connect multiple source systems to a single APM system. For example, when your company acquires another company, rather than immediately attempting to merge two systems together, you need to keep the systems running separately but want to implement strategies centrally. The two systems might be the same type or of different types. You can configure APM Connect to handle either scenario.

The steps to configure these scenarios is similar to configuring a single system; you repeat the steps that define the EAM system records and, after creating the intermediate repository for the first system, run a job that adds the other systems to the intermediate repository with any required extraction filters.

Multiple Source Systems of the Same Type

This scenario is most useful when you all systems you need to support are the same type. The context file configuration for each source system will look the same for the target APM and APM Connect system for all the source systems. The unique parts of the context file are those that describe the particulars of the source system, for example, the system ID and filters used.

Multiple Source Systems of Different Types

Use this scenario if you need to support multiple disparate systems, for example, an SAP and a Maximo system. In this case, you will need to configure context files for each different type of source system, each pointing to the same target APM and APM Connect system. This does not preclude having multiple systems of a specific type (for example, one SAP, one ServiceMax, and two Maximo).

Considerations

There are some things to consider when connecting multiple source systems to a single APM with APM Connect:

- You must make sure that each source system has a unique system ID.
- The logs will contain the messages from all of the source systems. Each message will identify the source system using the system ID.
- Some source system types have unique requirements that must be performed for each source system. For example, you must run the Static Data job for all SAP systems.
- Each source system in a cloud environment will need an intermediate repository, even though they are communicating with a single tenant.
- Do not schedule running the same adapter job types (for example, functional location extractions) simultaneously from different source systems.

Support for Multiple Culture Settings from a Single Source System

APM Connect enables you to send data to APM from a single source system that supports plants using different language or extraction requirements.

Important: This feature is not supported for Technical Characteristics, Work Management, Asset Criticality Analysis, Asset Strategy Management, or Asset Strategy Implementation.

Globalization has increased the need to improve management of assets in different culture settings. Your solution may involve including these new plants in a single source system that communicates with APM but requires the data to be presented to the user in their native language. You can accomplish this by configuring APM Connect so that the plants that require specific languages or extractions appear to be different source systems, one for each language or extraction requirement. This capability provides a better user experience for all users of APM regardless of their location.

A key advantage of this support is that you can combine your source systems and then configure APM Connect to extract the data correctly.

Considerations

- The user defined in the source system that communicates with APM must use the same decimal notation.
- You must have unique system IDs and the correct language parameter value or extraction requirements for each plant.
- You must configure filters to make sure that the data is routed correctly to the specific location.