

DIRECT FEED SOLUTION FOR AC OR DC ELECTRICAL ARC FURNACE

We're helping the steel industry meet the double challenge of decarbonization and grid stability.

DIRECT FEED - OUR SOLUTION DIRECTLY CONNECTED TO THE GRID.

Building on decades of expertise in the Metals industry, GE Vernova's Power Conversion & Storage business has developed an advanced solution to help steel producers optimize their OPEX, while delivering ultimate grid power quality.

Our power supply solution is directly connected to the grid and allows to precisely manage the furnace electrode current. The digital control system enables a qualitative monitoring of the electrical arc and prevent disturbances.



With our Direct Feed converter system, we offer a turnkey solution including:

- Multi-level converter system
- EAF transformer
- EAF control & regulation systems

We can also provide the full high voltage grid connection and distribution system, including HV/MV grid step-down transformer and GIS/AIS.

GE Vernova's Direct Feed system is based on proven press-pack IEGT technology offering high availability thanks to redundancy.

Steel production is a CO₂ and energy-intensive activity, which represents 7% of the global energy sector CO₂ emissions ⁽¹⁾. While global demand for steel is projected to increase by more than a third through to 2050 ⁽¹⁾, steel producers are committed to reducing the impact of their operations to comply with global energy and climate goals. There are several ways, relying on new technologies, to decarbonize the steel industry and more and more producers are considering transitioning from conventional steelmaking to Direct Reduced Iron (DRI) associated with arc furnace process, which generates 35–40% lower GHG emissions ⁽²⁾. Looking at the future, many of the world's biggest steelmakers plan to transition DRI facilities to use more hydrogen* in the mix or build new DRI plants that run almost entirely on green hydrogen*.

The global installed base of Electrical Arc Furnaces (EAF) is then expected to expand by three in the coming decades to meet the steel production processes shift. More plants, higher power –this results in increased stress on the grid, which stability is already at risk with the rising use of renewable energies. Consequently, grid operators are imposing higher power quality constraints to industrial companies, which must drastically reduce the electrical pollution like flicker or harmonics rejection.

Traditional compensation solutions like SVC or DSVC which used to be selected to match required power quality performance will not be sufficient in the future, even less for jumbo furnaces.



GE VERNOVA

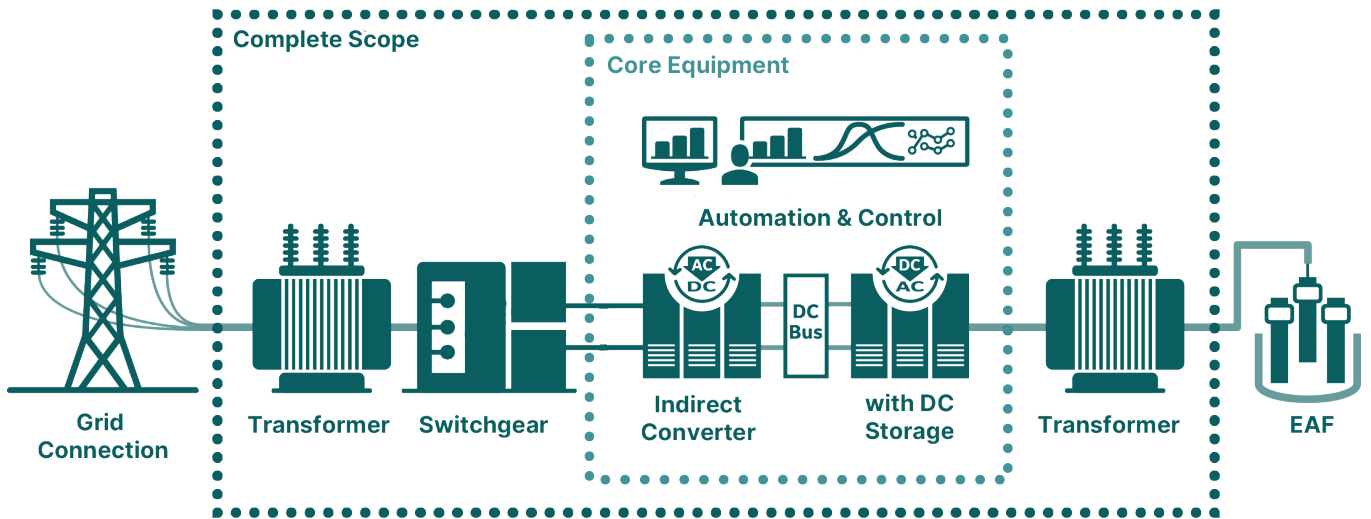

Compatible for both greenfield and brownfield as it can be located anywhere on site, usually close to the electrical substation,

Simplified EAF transformer,

No specific harmonic filters required,

Applicable for both AC and DC furnaces,

Easy to configure,

Scalable up to 400 MW,

Ladle Furnace compensation included.



BENEFITS

Compared with STATCOM system



Process performance

- Reduced electrical power consumption –stable operation,
- Improved power-on time,
- Significant reduction of electrodes consumption.



Life cycle/Reduced maintenance

- Limited usage of transformer tap changer,
- No reactor tap changer,
- Circuit breakers only switched at no-load.



Grid performance

- AF reactive power and harmonic current not propagated to the grid,
- Improved EAF flicker,
- Enhanced harmonic performance.

A comprehensive portfolio of solutions to ensure power quality

The Direct Feed system completes our portfolio of solutions to help steel companies operate efficiently while maintaining power quality and reliability, whatever the plant's size and the grid requirements.

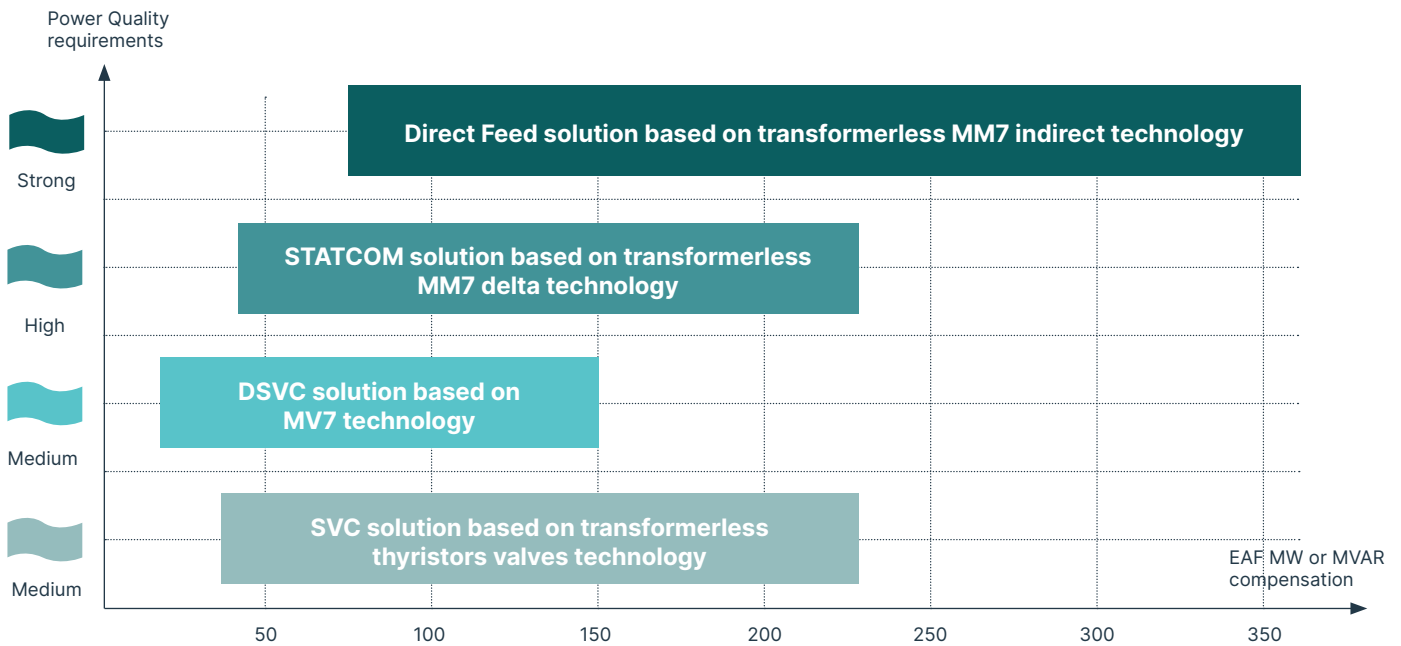

About Power Conversion & Storage, a GE Vernova business

GE Vernova's Power Conversion & Storage business combines advanced energy conversion and storage systems to meet the electrification needs of utilities and industries. With a focus on industrial electrification, power stability, and energy storage solutions, Power Conversion & Storage empowers customers by addressing their most complex electrification challenges and accelerating their transition to a sustainable, decarbonized future.

*Contact us to know more about our hydrogen solutions

www.gevernova.com/power-conversion

Glossary

AIS	Air Insulated Substation
DRI	Direct Reduced Iron
DSVC	Static Var Compensator based on IEGT technology
EAF	Electrical Arc Furnace
GIS	Gas Insulated Substation
IEGT	Injection Enhanced Gate Transistor
MMC	Modular Multilevel Converter
STATCOM	STATIC synchronous COMPensator
SVC	Static Var Compensator

Sources

- ⁽¹⁾ IEA - Iron and Steel Technology Roadmap
- ⁽²⁾ Berg- Huettenmaenn. Monatsh. 2020, DOI: 10.1007/s00501-020-00975-2