



# Products and Solutions for Research & Test Systems

# Research, development and test systems solutions

Robust product testing of critical equipment is the foundation for quality and reliability. It means manufacturers of critical equipment and research centers for industries such as renewables, automotive, DC- and microgrids, marine or aerospace need to stay ahead of the game. For example, simulating years of wear and exposure in months can lead to shorter development times.

GE provides adaptable, robust and dynamic test systems for efficient and reliable equipment operations across these industries. Our customized and turnkey solutions, combined with engineering and consulting expertise and project life cycle services, help to improve the performance of your products.

## Power Electronics

Offering high power density, reliability, availability and scalability.

### Models

- LV8 Series
- MV5 Series
- MV7 Series

### Technical Capabilities

- Output power: 0.25 to 120MW
- Output voltage: up to 13.8kV
- Output frequency: up to 1,500Hz
- Input frequency: 50 or 60Hz  $\pm$ 5%
- Variable-speed systems for main, major and auxiliary drives for IM, PMM
- HV/LV power supply

### Software

- Modular test bench software
- Standart interfaces

## Electric Motors & Generators

Reliable and efficient rotating machine technology.

### Models

- Induction motors
- Synchronous motors
- High-speed motors
- PM motors

### Technical Capabilities

- Speed: 40 to 30,000rpm
- Power: 1 to 100MW
- Voltage: Up to 13.8kV

## Automation & Control

**Maximize system availability and process uptime**

The controls executing across our automation and drive

systems platform are built using a mature suite of reliable and secure automation components assembled into modular, flexible and scalable automation solutions. Our solutions use modern interfaces like OPC-UA, IEC 61850 and web technologies to facilitate integration with customers' existing OT/IT infrastructures.

### Key Components

- HPCi: High-performance system controller for process control and automation
- PECe/PECeLite: Drive controllers with associated power interfaces (PIBs) and specialist control libraries
- Visor: Remote monitoring and diagnostics system to provide safe and secure remote service capability and connection to Predix for remote analytics

# LV8: Low voltage platform for module testing solutions

GE Power Conversion’s LV8 platform addresses R&D and technical development challenges in the most flexible way. Thanks to its modular design, the LV8 can be very easily adjusted to customer demands such as specific power ratings and dimension.

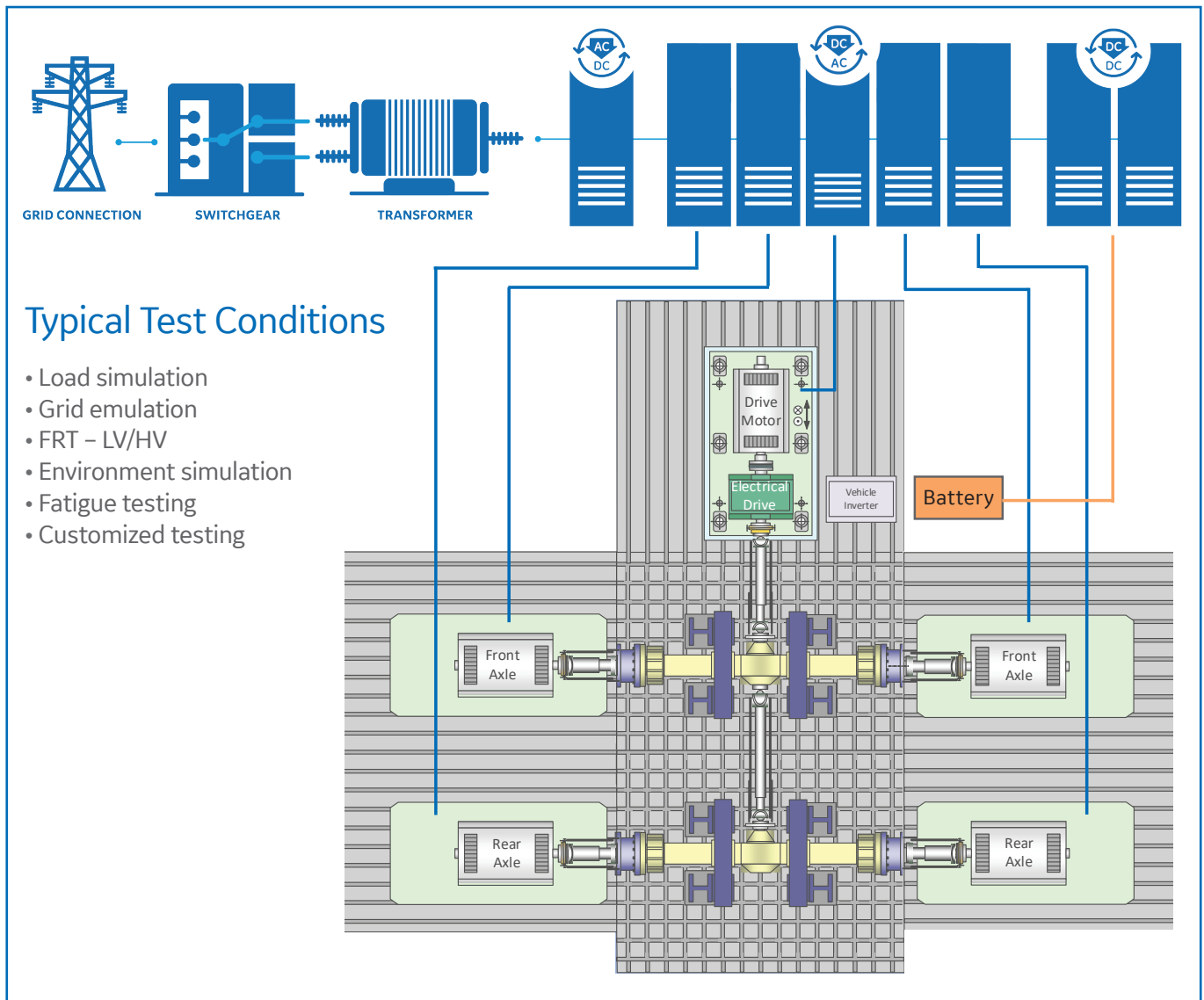

For more than 40 years GE Power Conversion is delivering equipment being used for testing automobiles and automobile components. The newly modified LV8 drive has been widely used for test bench applications. The successful testing of future E-drive technologies with LV8 test bench systems provides

comprehensive, reliable and relevant measuring results for alternative drives. This also encompasses simulation & testing of battery systems.

**Key benefits:**

- Modular design
- Adaptable to the most varied special requirements

- High efficiency of power electronics
- Advanced control structures for line converter, induction motors and permanent magnet synchronous motors
- Flexible overload cycles
- Real time ethernet control topology



# Critical Equipment Testing Solutions



## Automotive Test Systems

The automotive testing industry requires high performance, with highly innovative software features as a key to success. GE provides automotive testing solutions for combustion, drive line, electric & hybrid vehicles. The automotive industry is changing rapidly and forcing us to constantly deal with new challenges. The demand for electric vehicles is increasing worldwide while at the same time new testing capabilities are needed and customers are asking for cars with more custom design options – while for the coming years conventional drive trains will be in demand.

Advances in battery storage technology are constant. However, battery testing is inconsistent across all markets. Manufacturers are using different chemistries, formats, and processes. System integrators are developing systems that may be useful for one application, but inefficient for another. Flexible test benches are necessary to accommodate high testing accuracy of prototypes, pre-series and constantly changing products or partial systems to ensure long-term investment protection.

Based on our experience and know-how, and given the hardware and software available, we have developed systems, which can be easily combined with GE drives to provide high performance testing in the automotive industry for electric or hybrid vehicles and battery emulation. GE provides innovative software modules, e.g. the patented 300Hz ETPS engine torque pulsation simulation system which is an embedded feature of the drive software specifically for this industry segment.



## Wind Tunnel Testing Solutions

Wind tunnel testing plays a major role in the development of high-speed vehicles – not just around their aerodynamic form but also to ensure cooling air is effectively directed into the vehicle. GE's services cover all electrical equipment including drives, automation and visualization solutions. We have supplied systems to a variety of institutes and universities.

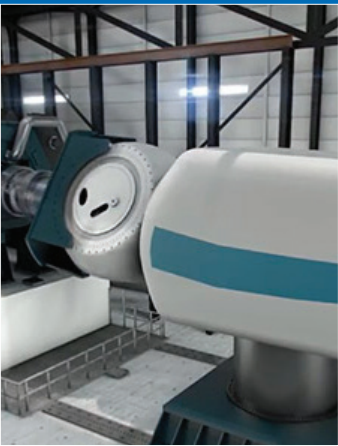

## Renewables Testing Solutions

Wind turbines and solar farms are increasingly contributing to meeting the world's energy demand. Such systems work often under extreme conditions and in remote places. Yet they're expected to provide maximum reliability and minimum lifetime costs without compromising performance – sustainably delivering power to the grid under varying environmental influences. Product life cycle testing and grid emulation are key for testing renewable power generation systems. GE offers consulting expertise, test systems and services that meet these requirements using a range of drives, electrical machines, test and simulation software.



## Test Benches for Compressors, Turbines, Generators and Gearboxes

GE delivers turnkey solutions, on-demand adaptable drive technology and energy-efficient solutions with high accuracy and speed. To help ensure the highest reliability, we develop and test units under worst-case conditions. Our offering covers the complete drive system from medium voltage down to the motor shaft.

Our mechanical construction expertise, combined with design and engineering, results in the manufacture of powerful testing solutions, from turbines and combustion engines to power trains and vibration simulation.

## DC- and Microgrid applications

In GE Power Conversion we think of microgrids as systems – configurable, flexible, and scalable. Identifying and developing microgrid solutions will allow us to enter new markets and regions, but the technology will also be a valuable addition to our portfolio for existing customers.

Some existing Power Conversion technology can be applied to microgrids, including converters, capacitor energy storage, battery energy storage, energy management system, power quality, DC breakers, and overall systems integration. GE Power Conversion’s biggest opportunity for microgrids though is our systems integration capabilities.

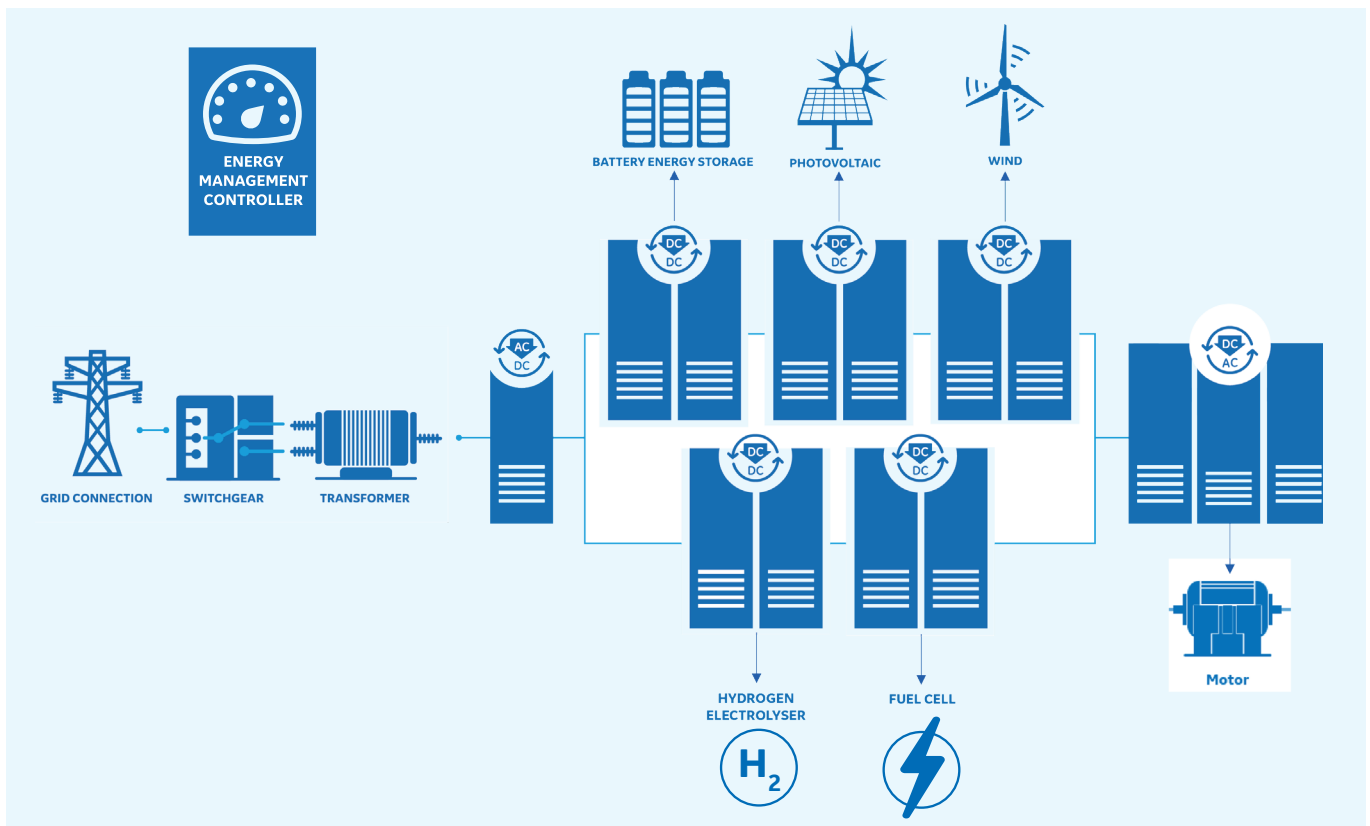

## Why do Microgrids matter?

- **They are reliable and flexible:** microgrids are designed to provide uninterrupted, 24/7 power and to balance load demands for an organization with changing power needs.
- **They are resilient:** microgrids aren't dependent on the traditional grid, their stability in bad weather is important for mission-critical structures such as hospitals and military bases.
- **They are more secure:** the microgrid's distributed generation (power is generated locally rather than transmitted from one central source) and smaller size make them easier to keep safe – both physically and, with the right control system, from cyber threats.
- **They can save money:** using sophisticated software, operators can optimize power usage based on demand, utility prices, and other factors.
- **They store and incorporate renewable energy:** this can save money and reduce carbon-dioxide emissions, as often required by government regulations.





For more information on  
GE Power Conversion's Research & Test  
System Solutions, please contact  
your local sales representative.