



GE Energy Connections | Power Conversion
In collaboration with GE Renewable Energy | Hydro



Connecting Water to Wire

GE's Hydro Pumped Storage Power Solutions:
**Having the right partner is as vital
as having the right technology**

Having the right partner is as vital
as having the right technology

www.gepowerconversion.com
renewables.powerconversion@ge.com

©2016 General Electric Company

© 2016, General Electric Company and/or its affiliates. GE Proprietary Information. All Rights Reserved. No part of this document may be reproduced, transmitted, stored in a retrieval system nor translated into any human or computer language, in any form or by any means, electronic, mechanical, magnetic, optical, chemical, manual, or otherwise, without the prior written permission of the General Electric Company or its concerned affiliate.

GEA32394 GEPC Hydro Booklet: Connecting Water to Wire

ge.com

Hydro Pumped Storage Solutions.

Facts & Figures

INDUSTRY

GE

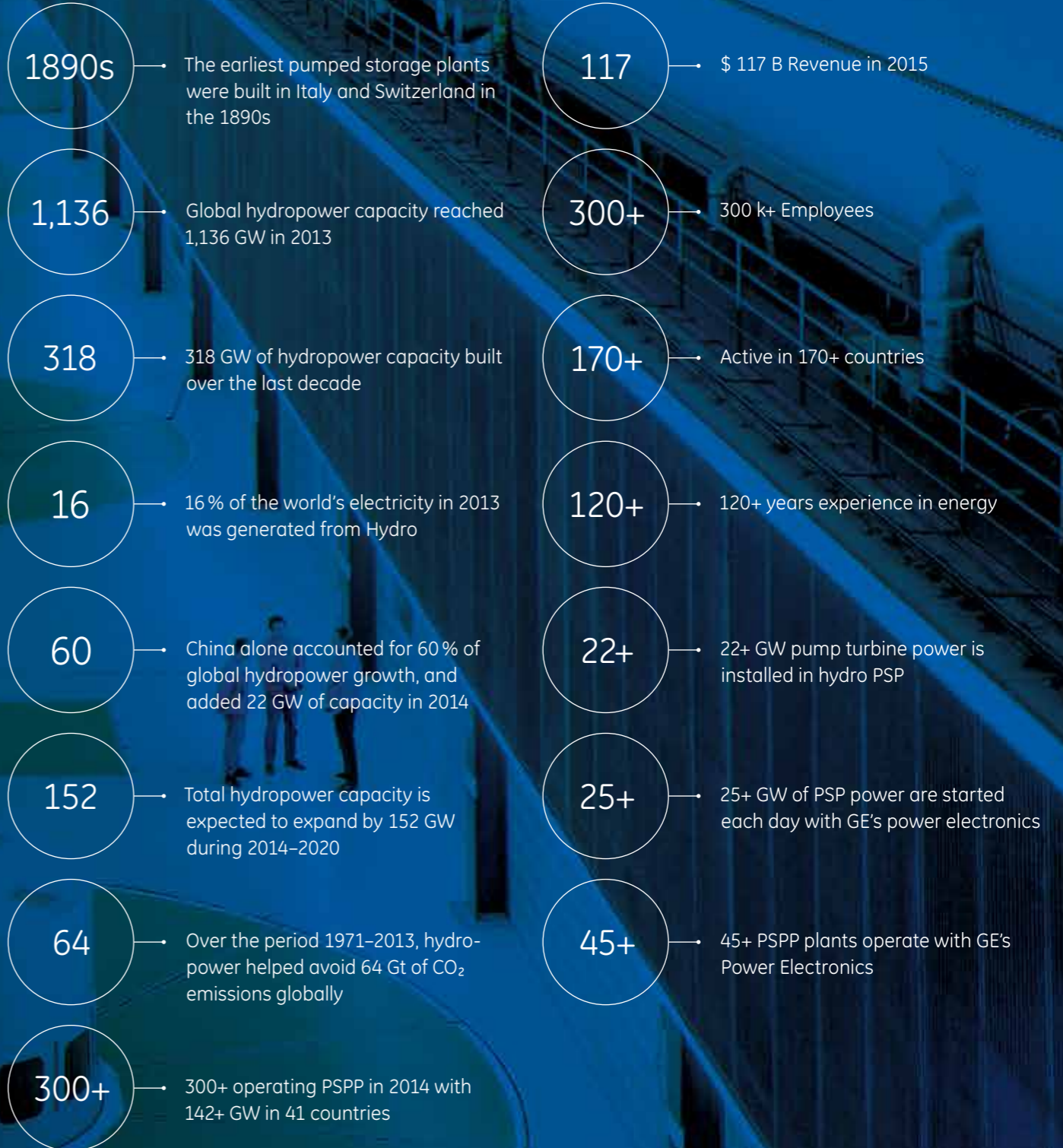

Contents

We don't just create power, we deliver it.
We don't just make electricity, we make progress.
We are at the heart of efficiently connecting electricity to industry.

- Industry Overview**
 - Energy Transition 7
 - Developments in Hydro 8
 - Hydro Technologies 9
 - Challenge for Pumped Storage Power 10

- GE Value**
 - The GE differentiator 13
 - From Water to Wire 14
 - Leading Technology for Your PSPP 16

- Integrated Solutions**
 - Our Key Building Blocks 18
 - PT Pump-Turbines 20
 - MG Motor-Generators 22
 - Power Electronics 24
 - SFC Start Up Frequency Converter 26
 - AC Excitation Systems 28
 - VSI Voltage Source Inverter Fully Fed 30
 - Control and Protection 32
 - Electrical Balance of Plant (eBOP) 33

- Systems Expertise**
 - Grid Integration & Consulting Services 34
 - Ancillary Services 35
 - Modelling and Simulation Capability 36
 - Hydro-Mechanical Equipment 37

- Premium Services**
 - Project Management 38
 - Global Partner with Local Footprint 39
 - Servicing over the Life-Cycle of PSPP 40

- Our Success** 44
- Contact Us** 45
- The GE Store** 46

Energy Transition

Renewables as a mainstream fuel

When it comes to how we generate electricity, a lot has changed in the last 20 years. Electricity generation from renewable energy has more than doubled and now contributes to 22 % of the global production of electricity with estimates predicting that, by 2040, it will account for 34 %. Moreover, this shift over the last 20 years is even more significant since it occurred over a period during which global demand for power has grown by more than 50 %. As markets grow, and the population increases, the world will continue to need increasingly abundant, clean and flexible power.

Attention continues to grow for the use of power generation resources that also have a limited environmental impact, and nations have been developing and implementing stringent national targets to support the future development of renewable energy sources. The installed capacity of renewables has grown by more than 100 GW per year over the past 4 years, with a record-high of 130 GW of new capacity installed in 2014. The result is that in 2014 renewables generated more than 5,400 TWh, accounting for approximately 40 % more than the total annual consumption of electricity in the United States.

As a result of continuous attention to the environment and the decreasing cost of technology, it is easy to predict that renewables will become a mainstream fuel in the future.

POWER GENERATION BY SOURCE

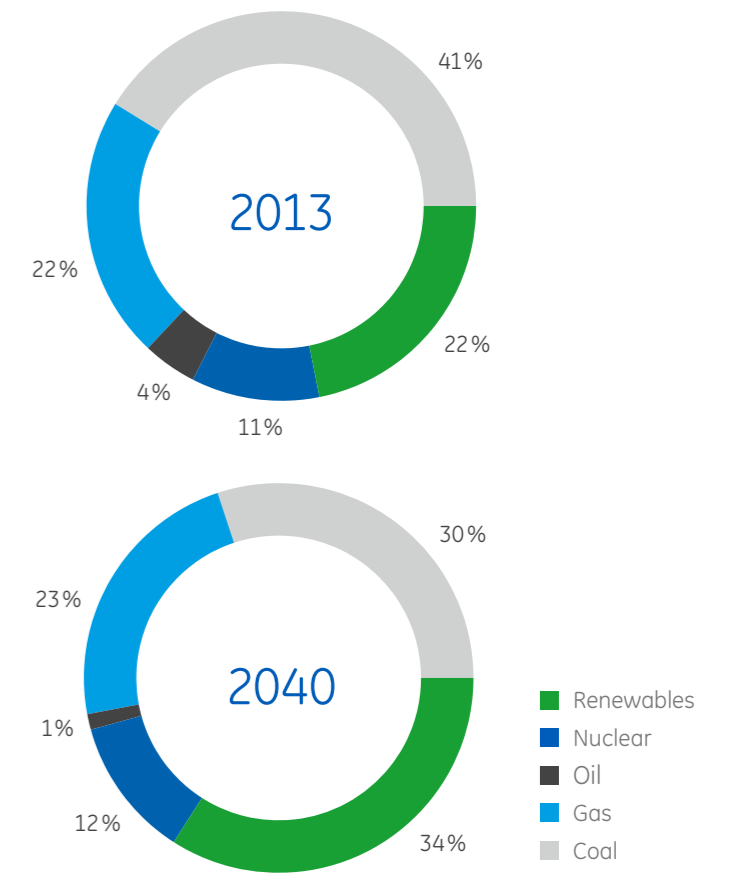

CAPACITY ADDITION (GW) 2014-2020

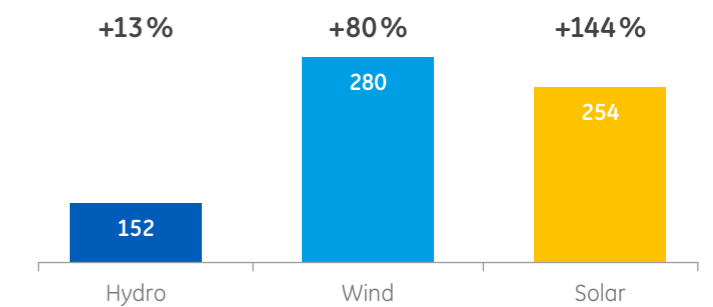

Data is based on IEA data from the World Energy Outlook 2015 and IEA Renewable Energy Market Report 2015 © OECD/IEA, IEA Publishing; modified by GE Power Conversion. Licence: <https://www.iea.org/t&c/termsandconditions>. BP Statistical Review.

Developments in Hydro

The primary producer of low carbon electricity

Hydro Technologies

MOST EFFICIENT

With most of today's media attention on solar and wind when it comes to renewable energy, it is easy to forget that hydro is not only the main source of renewable electricity but also the most efficient to date.

Moreover, hydropower is estimated to remain the leading source of renewables feeding into global power grids as projected growth is estimated at more than 25 % over the coming 25 years. Hydro's role as the key source of power is incontestable especially since it meets government agendas for sustainable greener energy sources providing substantial savings in CO₂.

MOST COMPETITIVE

Finally, when it comes to cost, nothing compares to the cost of electricity coming from a hydropower plant. It is by far the most competitive form of renewable energy. Considering the life-time of the plant, hydro has the lowest overall LCOE (levelized cost of electricity).

Today, only 30 % of global hydropower resources have been developed and the remaining 70 % located in regions where demand is slated to grow the fastest. This is especially true of China where policies aim at developing 350 GW of hydro and an additional 70 GW of pumped storage by 2020. Latin America is another region where the promise of hydropower is coming into its own as the continent plans an additional 110 GW by 2040. There is also significant untapped hydropower potential left to be seized upon in Africa.

HIGHEST CONTRIBUTION TO LOWER CARBON LEVELS

Hydropower has been at the heart of clean renewable energy for decades. It already contributed considerably by producing power that would have otherwise produced 64 Gt of CO₂ emissions between 1971 and 2013. Hydro-power has done more than any other low carbon technology, including nuclear, to limit CO₂ and will remain the primary producer of low carbon electricity until past 2040.

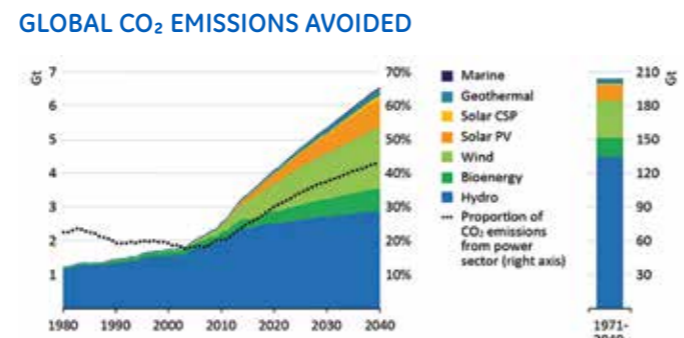
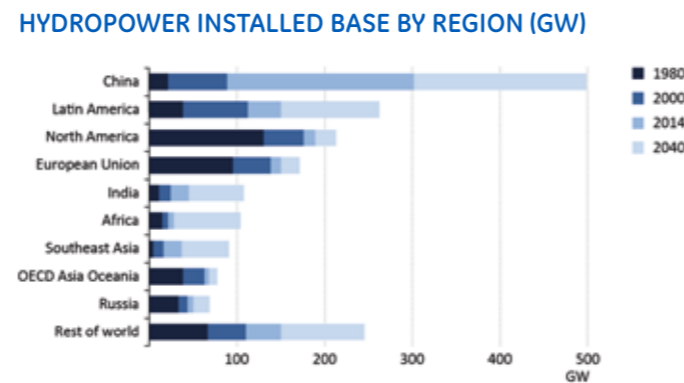
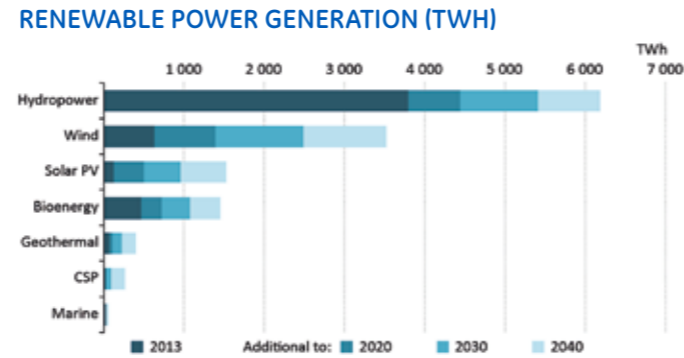

RUN OF RIVER
Up to 200 MW per turbine unit



TIDAL
~ 1 to 50 MW per turbine unit



RESERVOIR
Up to 1000 MW per turbine unit

PUMPED STORAGE
~ up to 500 MW per pump-turbine unit

Data is based on IEA data from the World Energy Outlook 2015 and IEA Renewable Energy MT Market report 2015 © OECD/IEA, IEA Publishing; modified by GE Power Conversion. Licence: <https://www.iea.org/t&sc/termsandconditions>.

Challenge for Pumped Storage Power

Years to build. Seconds to respond

LARGEST COMMERCIAL SCALE ENERGY STORAGE SYSTEM

Pump Storage Power Plants (PSPP) nowadays perform as the largest commercial scale energy storage systems. Their main functions are power generation from renewable hydro power, and supporting the local or national power grid during fluctuations.

The potential energy of water is stored by pumping water from a lower reservoir to a higher elevated reservoir during

low demand periods or overcapacity in the grid from wind and solar power. The water is being released quickly from upper to lower reservoir through turbines and generators to produce electric power when the electricity demand is high.

PSP plants have to be available on demand, to quickly balance load fluctuations, i.e. inject fast power to the grid in peak load times, or extract power from the grid in times of overcapacity e.g. when high amounts of solar or wind power feed the grid.

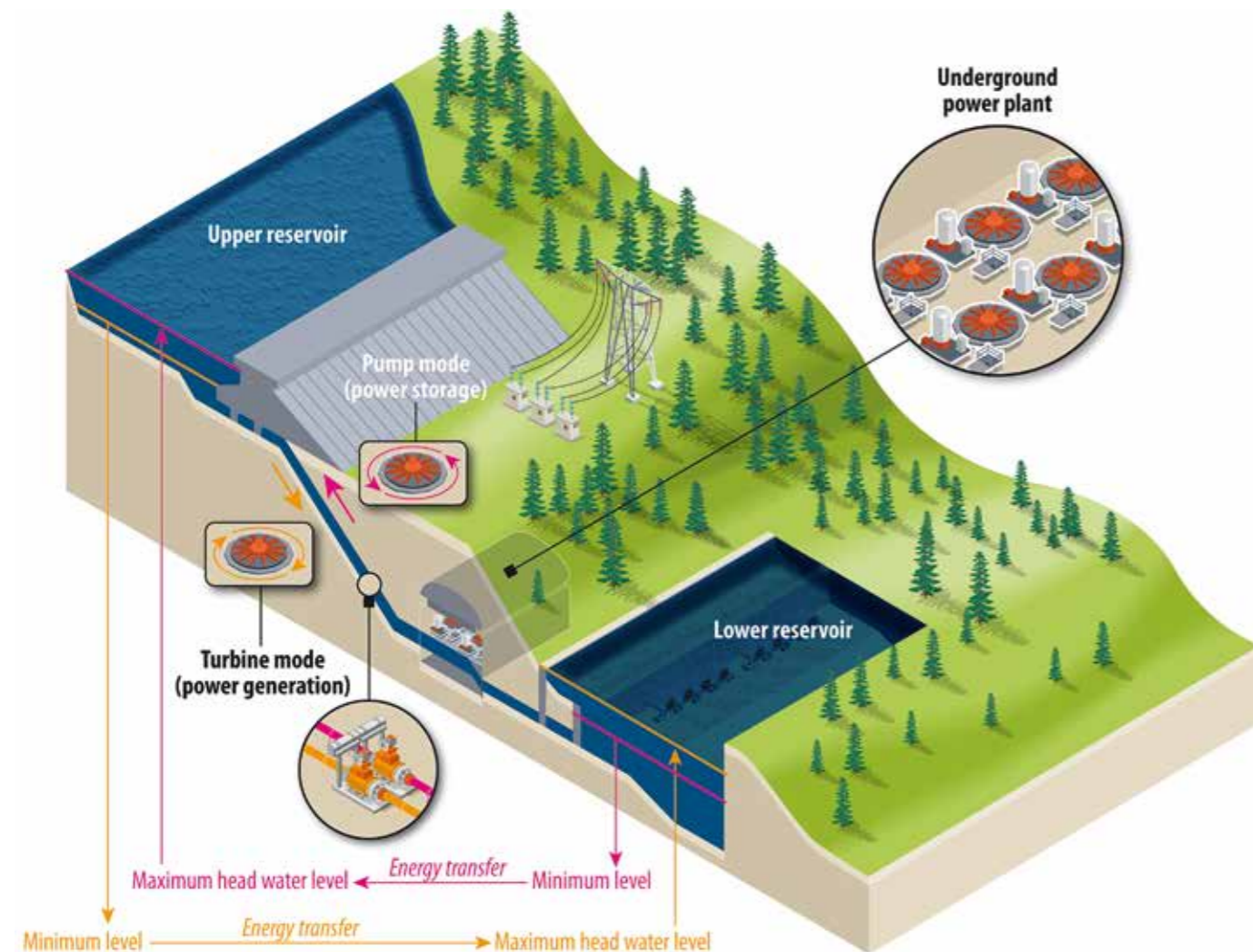

SECURE POWER SUPPLY, BLACK START IN A FEW SECONDS

With the large growth of intermittent renewable power feeding the grid, the complexity of managing grid fluctuations increases dramatically while grid modernization and expansion itself remains slow.

From fast response to small network fluctuations up to securing a stable power to avoid larger blackouts, pumped

storage plants are designed to dynamically react within a short time by generating the required electricity or by absorbing any excess, helping to keep the local or national grid stable.

Modern systems have capability to start the pumps or turbines up from a standstill rapidly. Even in the event of a power failure, with its black start capability, PSPP can re-establish the power supply to the network without an external energy supply.

POWER PLANT TYPE:	NUCLEAR	HARD COAL	LIGNITE	CC GAS	PSPP
START-UP TIME COLD (~ HOURS)	40	6	10	<2	0.1
START-UP TIME WARM (~ % PER MIN.)	40	3	6	<1.5	0.1
LOAD GRADIENT INCREASE NOMINAL OUTPUT	5%	2%	2%	4%	>40%
LOAD GRADIENT DECREASE NOMINAL OUTPUT	5%	2%	2%	4%	>40%

Source: VGB/Eurelectric

LONG PROJECT CYCLE FROM CONCEPT TO OPERATION

PSPPs plants are being built as large scale energy storage solutions in regions with relatively high contribution of intermittent wind and solar energy as well as nuclear based power generation.

Investments in PSPP are focused on a long-term basis, with a return of investment after several years of operation.

- Key drivers for investment decisions are
- Earnings on energy sales and grid services
 - Investment costs and time
 - Regional electrical grid requirements
 - Environmental conditions and public policies

The approval and planning process of PSPPs plants involves several private and public stakeholder i.e. environmental and country specific authorities, landscape architects, transmission grid operators, dam and civil work companies as well as design, engineering and equipment suppliers.

Until the first power feeds into the grid, the PSPP project realization time usually takes 5 or 10 years. The successful completion of such a large and complex project requires a strong collaboration between all involved project members and a high level of expertise.

Grid support.
 Energy output.
 Cost. Whatever
 matters most, we
 build customized
 solutions to meet
 your specific
 needs.

The GE Differentiator

Energy output | Grid support | System expertise

Whatever matters most, we build customized solutions to meet your specific needs

INDUSTRY-LEADING TECHNOLOGIES AND INTEGRATED SOLUTIONS

As one of the world leaders in hydropower, GE has been providing industry-leading technologies for over 50 years.

EACH PUMP STORAGE PROJECT IS UNIQUE

With our full range of water to wire solutions, we help you to optimize grid performance, reduce system and operating cost, enhance energy output and lower overall project risk by benefiting from our enterprise synergies.

WE ADDRESS, WHAT MATTERS MOST TO YOU:

Meet storage and grid support needs

Higher power output enabling better returns

Customized solutions: best value for cost

Smooth execution during project phase

WATER TO WIRE SOLUTIONS

- Leading technology based on standardized components as building blocks for power generation, conversion and grid connection
- Extension to your design institutes and engineering teams
- GE's enterprise synergies for your benefit

HOLISTIC SYSTEM APPROACH

- Modelling and Simulation capability
- Grid integration and energy consulting
- Ancillary services
- Control & Protection, Asset Performance Management

SERVICES – GLOBAL AND LOCAL

- Full line portfolio from day 1 to end of lifetime
- Service agreements from frame agreement to full O&M package
- Retrofit with latest technologies

INTEGRATED SOLUTIONS

SYSTEMS EXPERTISE

PREMIUM SERVICES

Connecting Water to Wire

Our offering for up to 500 MW per unit in large hydro pumped storage

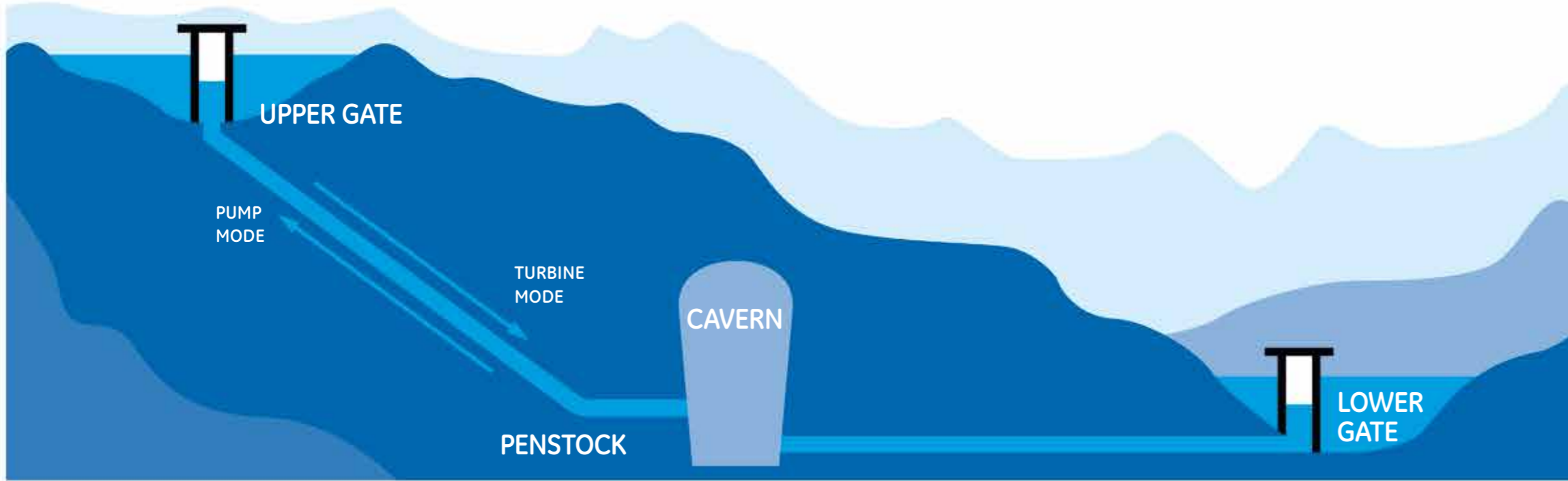

- PPT Pump-Turbinespage 20
- MG Motor-Generatorspage 22
- Power Electronicspage 24
- Control and Protectionpage 32
- Grid Integration & Consulting Servicespage 34
- Hydro-Mechanical Equipmentpage 37

HYDRO-MECHANICAL EQUIPMENT

- Penstock
- Valves
- Gates
- Pipes

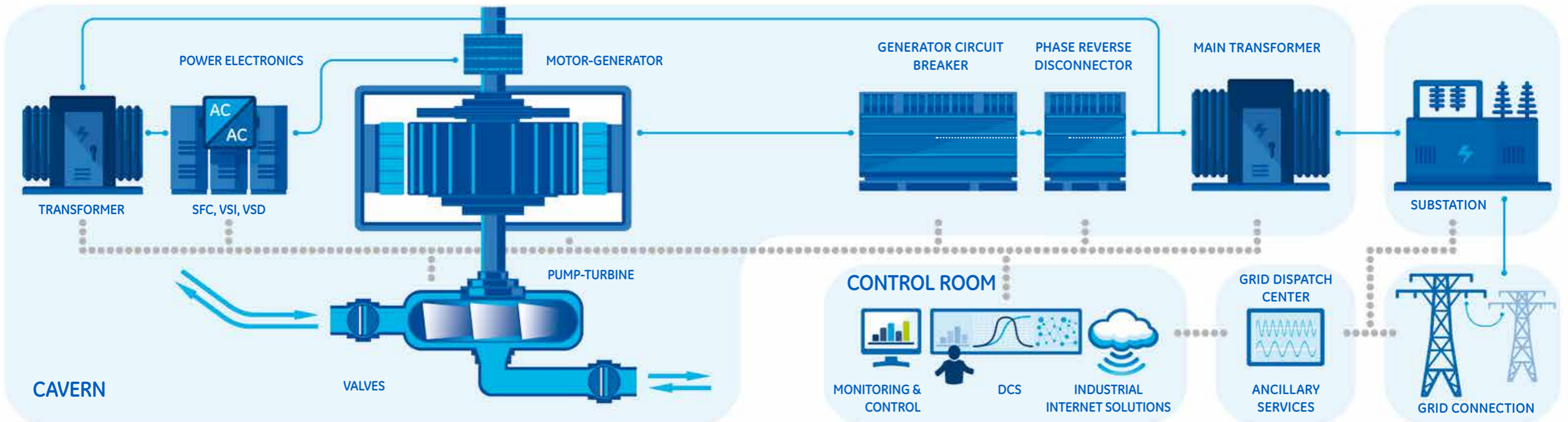
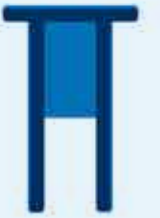

Leading Technology for Your PSPP

Typical pumped storage power plant configurations

MULTIPLE REASONS FOR INVESTING IN A PSPP

When investing in a PSPP, the decision consortium identifies and defines the main requirements that the PSPP has to fulfill.

Reasons may vary, e.g. the main drivers may be to produce power from water as renewable energy source, or to balance the grid, or to build a large scale energy storage system to help manage the national power grid and security of supply. Investors and decision makers need to identify the best technology suitable to meet the specific purpose that matters most.

GE TECHNOLOGY TO HELP OPTIMIZE BY COST, OUTPUT AND/OR GRID SUPPORT

GE offers integrated solutions for conventional fixed speed, as well as variable speed doubly or fully fed systems helping to minimize cost, maximize energy output and provide optimal grid support.

Overview of different PSPP systems

		FIXED SPEED	VARIABLE SPEED		TERNARY
			DOUBLY FED	FULLY FED	
COSTS	INTEGRATION & EQUIPMENT	\$	\$\$	\$\$\$	\$\$\$
SPACE	ELECTRICAL & HYDRAULICS	LOW	MEDIUM	MEDIUM-LARGE	LARGE
OVERALL EFFICIENCY	TURBINE MODE	MEDIUM	MEDIUM-HIGH	HIGH	MEDIUM
	PUMP MODE	HIGH	MEDIUM	MEDIUM	LOW*
REGULATION FLEXIBILITY	TURBINE POWER	MEDIUM	MEDIUM-HIGH	MEDIUM-HIGH	HIGH
	PUMP POWER	LOW	MEDIUM	MEDIUM-HIGH	HIGH
TRANSFER TIME	PUMP → TURBINE	MEDIUM	MEDIUM	MEDIUM	FAST
	TURBINE → PUMP	SLOW	SLOW	MEDIUM	FAST
REACTION	50 % POWER SWING	MEDIUM	FAST	FAST	MEDIUM
REFERENCES	GLOBAL (ALL SUPPLIERS)	HIGH	MEDIUM	LOW	LOW

*Considering hydraulic short circuit

SOFT STARTER

Conventional fixed speed systems, SFC

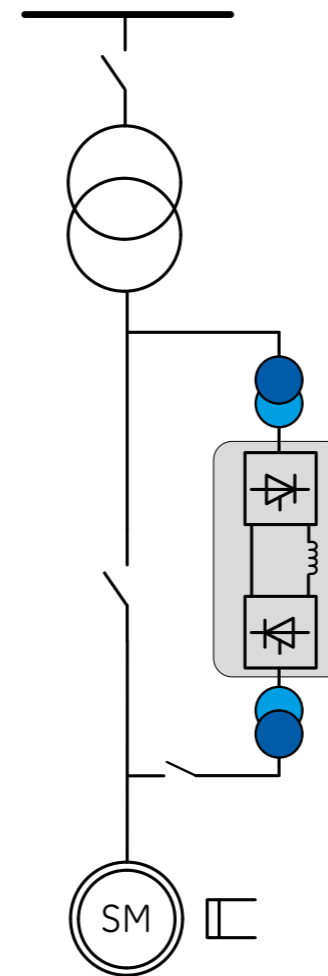

AC EXCITATION

Variable speed driven systems, doubly fed VSI

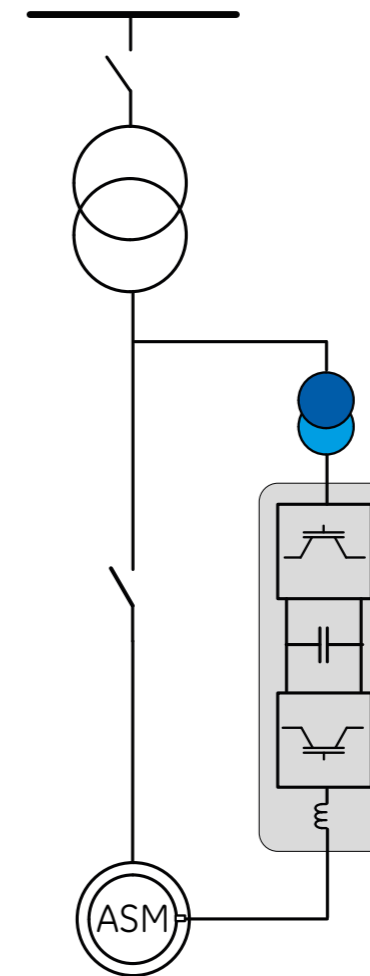

CONVERTER

Variable speed driven systems, fully fed VSI

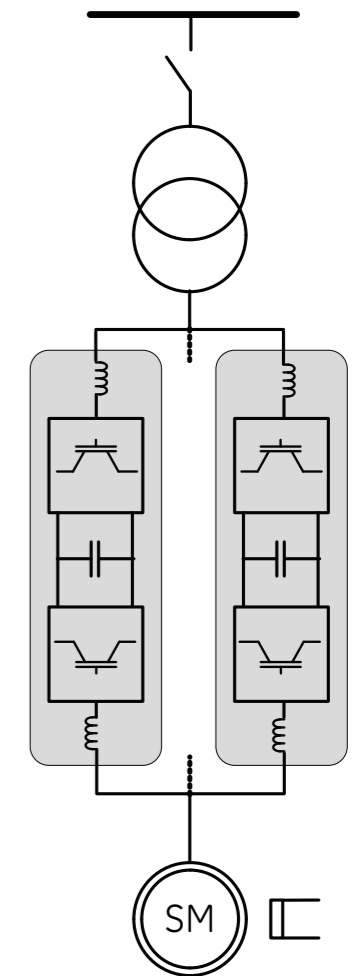

Blue: Converter transformer
 Grey: Power electronic modules
 SM: Synchronous Machine
 ASM: Asynchronous Machine
 SFC: Start up frequency converter
 VSI: Voltage Source Inverter

Our Key Building Blocks

For customized system solutions to meet your specific needs

POWER ELECTRONICS

- Dynamic grid support
- Increased plant efficiency
- Soft starting of pump turbine
- Flexibility across the full operating range of the turbine

MOTOR-GENERATORS

- Largest hydro generator reference base
- 135+ PSPP units delivered over 50 years globally
- 56+ GW of pump-turbines and motor-generators installed

PUMP-TURBINE

- Turbine design for higher efficiency area
- Pump design for low cavitation, stable operation at high head, unit setting
- Low vibration for both operation modes

PT Pump-Turbines

High efficiency design

SETTING THE STANDARD FOR HYDROPOWER EFFICIENCY

GE provides a full range of hydro turbines with market-leading technology. Our dedicated Global Technology Centers use sophisticated tools and testing facilities to ensure our turbines are among the leaders in the market in terms of efficiency. Our decades of knowledge and experience in hydropower make GE the right provider to configure a solution to meet our customers' specific needs.

CONTINUOUS IMPROVEMENTS FOR OUTSTANDING RECOGNITION

Main pump-turbine key indicators:

- Large product portfolio contains single, double and multi-stage pump-turbines
- Pump design for low cavitation, stable operation at high head, unit setting
- Turbine design for highest efficiency area
- Low vibration for both operation modes
- Large development and test lab facilities

TURBINE DESIGN ENABLING HIGHEST EFFICIENCY AREA



CFD calculation of pump-turbine runner
CFD: computational fluid dynamics

OUR OFFERING FOR HYDRO PUMP-TURBINES

With our extensive hydraulic design portfolio, GE is able to provide a solution adapted to our customers' specific needs in a variety of environments.

GE's complete line of pump-turbine offerings are suited for heads from 5 m to 1,200 m and have production potential ranging from 50 MW to 500 MW. Our pump turbines are adapted to the specific characteristics of each PSPP.

Each PSPP plant is unique, therefore we offer

- Each turbine runner is custom designed to meet specific conditions of each project
- Simulation of hydraulic transients
- Advanced CFD software used to determine size and shape of runner
- Full line Service portfolio to support all your operational needs
- Integration studies for smooth mechanical and electrical equipment and grid integration
- Scale models tested in GE's hydraulic labs
- Each runner is custom manufactured and precisely machined

KEY BENEFITS

- High efficiency levels up to >80% of plant energy output for full turbine pump cycle
- High reliability

OUR SUCCESS

- More than 135 PSPP units delivered over 50 years globally
- More than 56 GW of pump-turbines and motor-generators installed

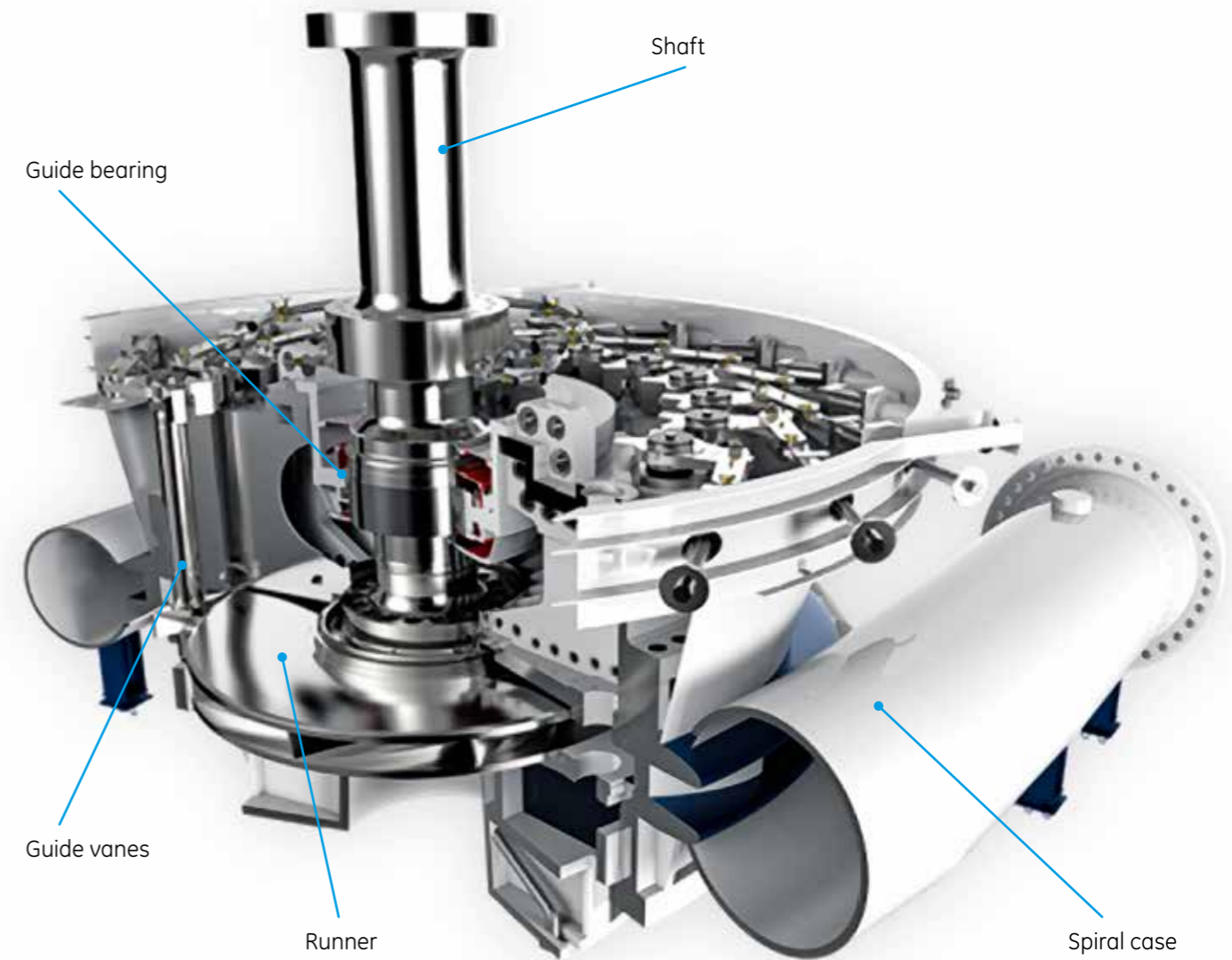

FEATURES

- Plant configurations that allow turbine dismantling from above, below, or in the middle of the pit
- Self-pumping bearings, PEEK polymer coated bearings, and traditional oil-lubricated metal coated bearings
- A variety of governing control system configurations
- A wide selection of inlet valves
- Double and multi-stage centrifugal units for heads over 700 m

TECHNICAL DATA

- Power: up to 500 MW
- Speed: up to 500 rpm
- Runner diameter: up to 5 m

MG Motor-Generators

Proven machine technology



CONTINUOUS IMPROVEMENTS FOR OUTSTANDING RECOGNITION

Over the past 50 years, GE has supplied more than 260 motor-generators for pumped storage plants world-wide. Main generator references comprise:

- More than 135 PSP units globally
- More than 56 GW installed references
- Rated voltage up to 21 kV

OUR OFFERING IN HYDRO APPLICATIONS

Our range of hydro motor-generators is designed for

- PSP conventional fixed speed
- PSP variable speed
- Small to large power
- Low to high speed
- Water and air cooled machines

Each PSPP is unique, therefore we offer

- Customized engineered solutions
- Full line Service portfolio to support all your operational needs
- Integration studies for smooth mechanical and electrical equipment and grid integration

LARGEST HYDRO GENERATOR REFERENCE

GE has the largest hydro generator reference for all kinds of hydro plant applications: Run of river, large hydro, pumped storage power (PSP) in both conventional fixed speed and variable speed PSPPs.

This outstanding market recognition is the result of sustained R&D efforts that have led to continuous technological improvements. These are the cornerstones that have contributed to the high availability and stability of our generators and motor-generators over several decades.

KEY BENEFITS

- High efficiency levels up to >98.5 %
- High reliability
- Low maintenance due to proven designs based on 260+ MG units for PSP installed globally
- Long lasting performance
- Electrical insulation system with more than 50 years in operation

ASYNCHRONOUS MACHINE FOR DOUBLY FED VARIABLE SPEED

SYNCHRONOUS MACHINE FOR FULLY FED VARIABLE SPEED AND CONVENTIONAL FIXED SPEED

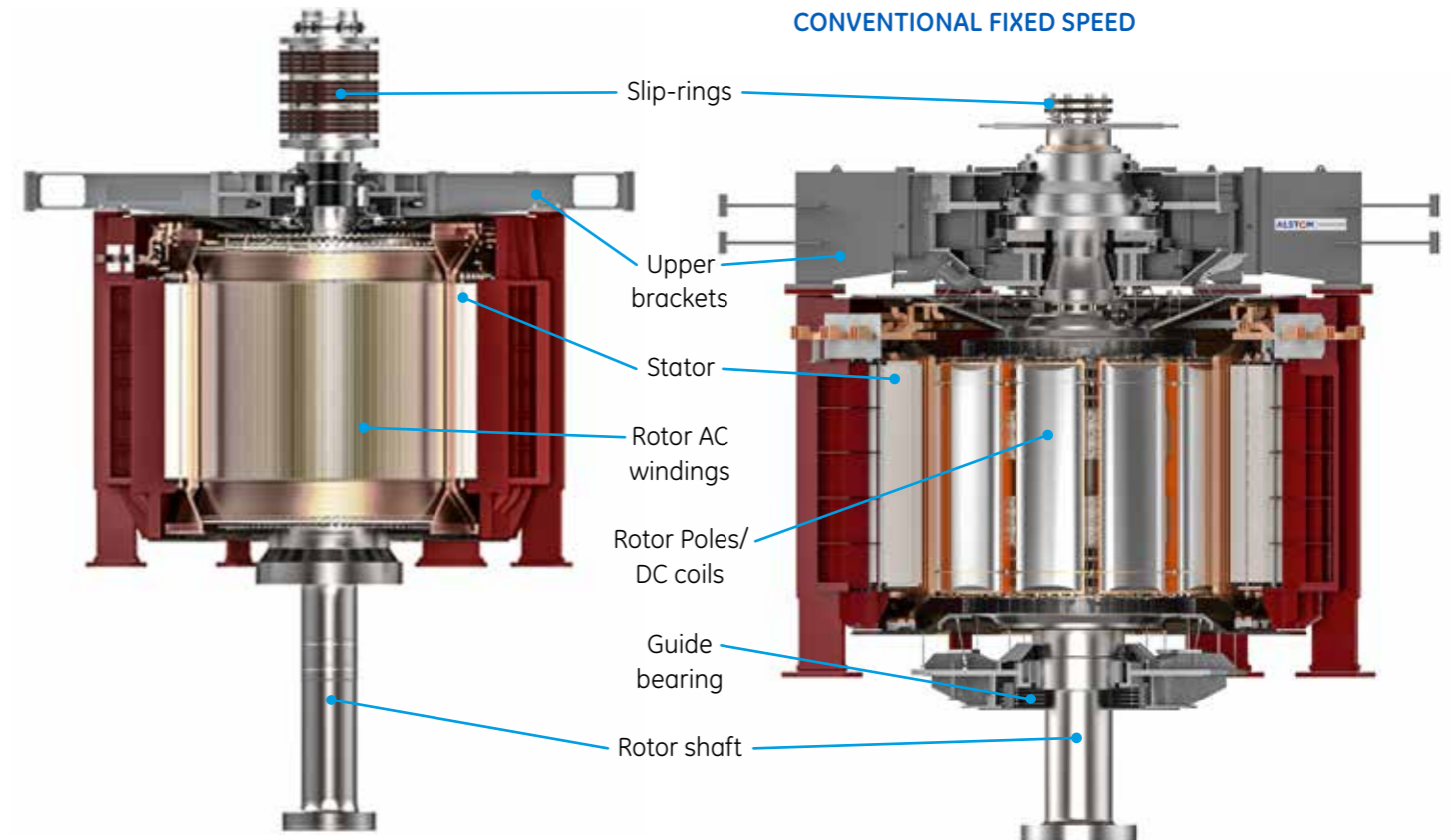

FEATURES

Motor-generator units are subject to numerous thermal cycles and high centrifugal forces and need to withstand potential fault disturbances such as short circuits. Taking into account these requirements which are particularly important for peak-load units, we incorporate the following features in our design of motor-generators:

- Structural design with oblique elements
- State-of-the-art thrust bearings
- Permanent pre-stressed stator core
- VPI insulation system and slot ripple spring (reliable even under extreme operating conditions)
- Self ventilated rotor rim (standard or high speed design)
- Bent pole coils (for easier assembly and better surface cooling)

TECHNICAL DATA

- Active Power up to 500 MW*
- Stator Voltage: up to 21 kV*
- Speed: up to 750 rpm*
- Rotor diameter: up to 10 m*

*Design criteria based on pump-turbines parameters and interaction of project specific of parameters.

Power Electronics

Adjustable pumping power and fast response time

UNIQUE EFFICIENCY AND FAST RESPONSE TIME

Power electronics enable an efficient and flexible conversion and conditioning of electrical energy. They usually involve a controlled change of voltage/current level and/or frequency, controlling power levels from milli-watts such as in portable appliances through gigawatts as in HVDC transmission lines. Power electronics help to connect renewable energy sources to the grid or maintain security of supply in future power networks due to their unmatched fast response time to network fluctuations. In the industrialized countries, up to 50–60% of electrical energy is consumed by motor drives. The use of highly efficient power electronics enables the operator to capitalize on energy savings as a new “source of fuel”.

APPLICATIONS

PSP historically operate the motor-generators and pump-turbines with electromechanical fixed speed drive solutions, whereas newer systems adopting more modern variable speed drive systems, covering the range from only a few % up to 100% speed variation.

OUR POWER ELECTRONICS OFFERING

Our highly reliable power electronics offering comprises proven thyristor and IGBT-based technology with demonstrated capability and longevity across all industries in harshest environments while meeting most stringent grid codes.

Since each PSP is unique in its location and requirements, our power electronics building blocks enable us to design customized solutions to meet your individual customized needs.

SFC – START-UP FREQUENCY CONVERTERS

Smooth start-up reduces mechanical stress and extends time life of rotating parts.

- Thyristor based
- For fixed speed motor-generators

AC EXCITATION/VSD VARIABLE SPEED DRIVE

Key functions are: excitation, speed control, start in pump mode, black start capability.

- IGBT based
- For doubly fed induction motor-generators

VSI – VOLTAGE SOURCE INVERTERS

Speed control for the pump turbine and allow to operate at optimal efficiency across different load conditions.

- IGBT based
- For fully fed motor-generators

The GE Value

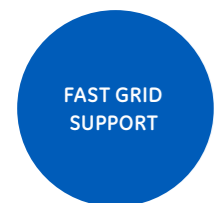

ENHANCED STABILITY AND RELIABILITY OF DOMESTIC GRID

- Lower stress on equipment
- Fast dynamic response, thus ability to balance wind/solar units
- Higher efficiency and output reduces need for thermal plant cycling
- Quick ramp up/down of PSP supporting intermittent renewables feed-in
- Frequency regulation in pumping mode to accommodate grid fluctuations

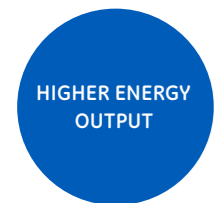

UP TO 10% HIGHER ENERGY OUTPUT

- Adjustable pumping power allows turbine to operate at optimal efficiency across different load conditions
- Higher efficiency due to low losses thanks to power semiconductor devices

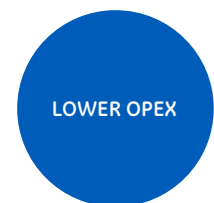

EXTENDED EQUIPMENT LIFESPAN AND LOWER MAINTENANCE COST

- Better power quality and smoothed transients help to reduce stress on mechanical and hydraulic equipment
- Operation at peak efficiency
- Store energy when electricity cost is low: take advantage of shifts in grid dynamics to effectively manage variable energy supply and store lower cost energy

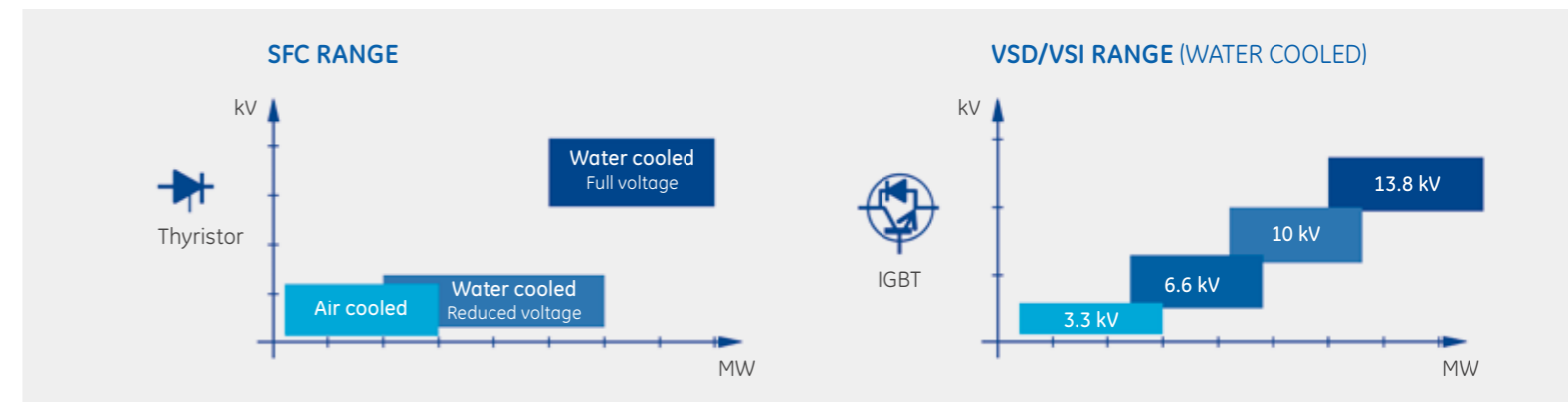

OUR SUCCESS IN POWER ELECTRONICS

- 40+ years of experience across all industry sectors
- 3+ GW installed capacity in SFC, thereof 730 MW in PSP
- 12+ GW installed capacity in VSI, thereof 810 MW in PSP

POWER ELECTRONICS VS. PSP POWER

- To drive 1 GW PSP power, you need approx.
- 20 MW SFC for fixed speed MG
 - 200 MW of AC Excitation for doubly fed MG
 - 1 GW of VSI for fully fed MG

SFC Start Up Frequency Converter

Smooth start-up and extended equipment life for fixed speed PSPP



THYRISTOR BRIDGE FOR SFC CUBICLES



FAST POWER TO THE GRID AND NETWORK SYNCHRONIZATION

Every day, more than 25 GW installed capacities in PSPPs are successfully started by GE's SFCs around the world. SFCs start the turbine in pump mode and smoothly synchronize with the network frequency. A SFC also serves as a dynamic brake to coast down the unit in both pump and turbine modes. To start the unit in pump mode, the SFC is operating the generator as a motor, under variable frequency and variable voltage.

SMOOTH START UP FOR EXTENDED EQUIPMENT LIFE

- Reduced mechanical stress and extend life time of rotating parts
- No tear and wear in the fully static Static Frequency Converter
- Lower system cost due to one common equipment for up to 4 units
- Lower maintenance cost due to higher reliability
- Flexibility to be used for rotor balancing to facilitate maintenance e.g. for bearing inspection and shaft maintenance
- Avoids network disturbance in pump mode, resulting in lower stress on the motor-generator

KEY APPLICATIONS

Pumped Storage Plants, Synchronous Condenser Plants, Gas Turbine Starters.

FEATURES

- Deionized water cooling allowing higher power density, thus smaller space requirement
- Full or reduced voltage SFC with step-down and step-up transformers, depending on G/M rating and required starting time

TECHNICAL DATA

- Power up to 40 MW
- Voltage: up to 21 kV

TYPICAL CONFIGURATIONS OF SFC CUBICLES

20 MW SFC

- reduced voltage, using step-down and step-up transformers
- 12 pulses on network side
- 2 x 3 thyristors in series
- Dimensions (mm): L = 9,000; W = 2,000; H = 2,400

40 MW SFC

- rated voltage, 15.75 kV
- 12 pulses on network side
- 2 x 5 thyristors in series,
- Dimensions (mm): L = 13,000; W = 2,400; H = 2,700

28.8 MW SFC

- at rated voltage, 21 kV
- 18 pulses on network side
- 3 x 4 thyristors in series
- Dimensions (mm): L = 6,000; W = 5,000; H = 6,000 (open skid inside a building)

AC Excitation Systems

Partial variable speed control for doubly fed motor-generators

HIGHER ENERGY OUTPUT AND BLACK START CAPABILITY

Variable Speed Drives (VSD) on excitation are being used to increase the turbine efficiency allowing "the plant" to produce more electricity in turbine mode, or consume less electricity in pump mode.

Main functions of the AC excitation system:

- Excitation/AVR (Automatic Voltage Regulator) function of the DFIM Generator-Motor including output power control of the unit
- Speed variation, typical $\pm 10\%$ around synchronous speed
- Starting in pump mode by using the AC excitation as Variable Speed Drive (VSD) and launching the unit within a few minutes to the grid, having the runner dewatered
- In addition, black start and line charging are inherent functions the AC excitation could provide

EXTENDED TURBINE OPERATING RANGE AND DYNAMIC GRID SUPPORT

GE offers fully integrated systems bringing consistent technology through all the controllers, plant DCS, Pump-Turbine governor, AC excitation controller, speed-power optimizer. The full controller topology is tested in house on real time simulator, reducing time spent on the field, and providing remote support.

GE's VSD/AC excitation systems enable:

- Higher flexibility: power in pump mode can be varied by 30%, providing grid frequency control in this mode as well
- Higher efficiency: speed variation is keeping the Pump-Turbine operating on top of its hill chart even for large head variations
- Higher output: Pump-Turbine cavitation and vibration zones are pulled back, extending the operating range, reducing wear, increasing reliability
- Contribution to grid stabilization thanks to higher dynamic power control, increasing flywheel effect

AC EXCITATION ENABLES HIGHER TURBINE EFFICIENCY

i.e. more electricity output during turbine mode, and lower electricity consumption while in pump mode.

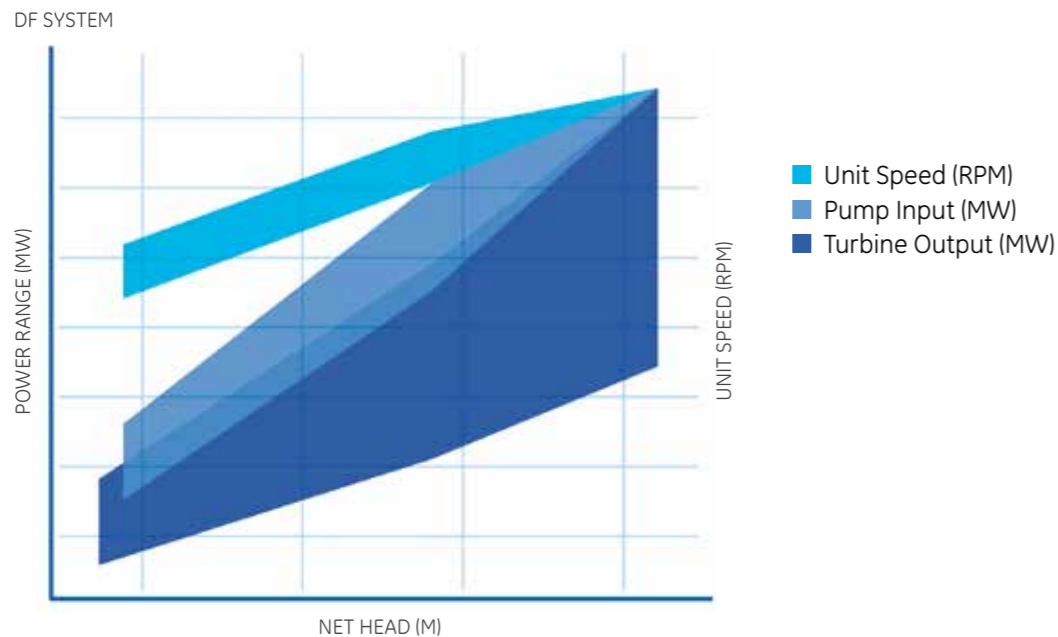

FEATURES

- Deionized water cooled
- Modular concept
- Compliance with grid codes
- Digital integrated protections
- Dedicated PWM (Pulse Width Modulation) patterns

TECHNICAL DATA

- Power up to 60 MW for DFIG turbine systems
- Power up to 300 MW for FF turbine systems

POWER

- For DFIM systems: up to 60 MW
- For FF turbine systems: up to 300 MW

DIMENSIONS

Depending on customized solution.
Typical configuration consisting of 4 modules in parallel:
4 x (L = 7,000 mm; W = 1,000 mm; H = 2,450 mm)

VSI Voltage Source Inverter Fully Fed

Full variable speed control for synchronous motor-generators

Full flexibility across the complete operating range

GE offers high power topologies meeting the motor-generator rated voltage without the need for a interposing transformer. Several identical 5 levels PWM VSI modules used in all industry sectors are assembled together through interlacing reactors, on both AC ends. It results a multi-level output voltage waveform suitable to operate even existing generators.

Complementing the benefits as described for the doubly fed system, our VSI additionally enables:

- Full flexibility across the complete operating range of the turbine
- Faster availability i.e. no need to dewater the runner any more, the pump is in service within a few seconds, and no need to synchronize the motor-generator to the grid.
- Smoother transient, less hammer effect on hydraulic and penstock

HIGHER PLANT PERFORMANCE DUE TO FULL FLEXIBILITY ACROSS THE OPERATING RANGE

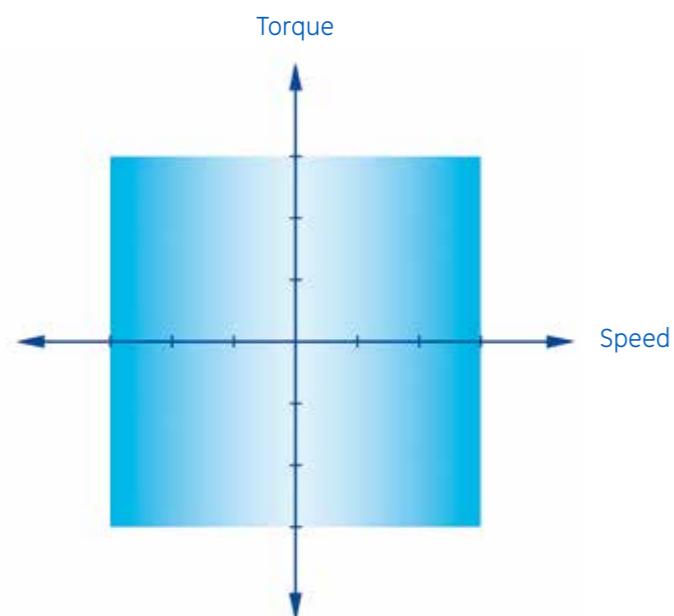

Improve your plant performance

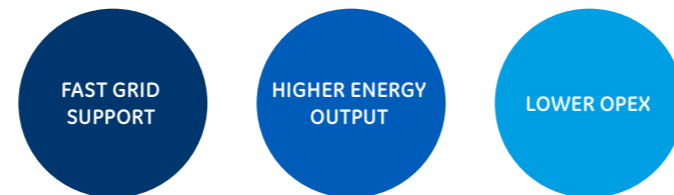

GE's VSI provides ancillary services for improved grid support, such as reactive power control or primary frequency response, even in pump mode.

VSI is suitable for upgrading existing plants to help increasing energy output. The converter could be designed for 70 to 80% of the rating which enables an extension of the turbines operating range, when it is too far from its rating e.g. caused by low water levels stored in the reservoir, leading to lower head and lower flow.

VSI enables optimization of the motor-generator. When it is no longer coupled to the grid, the synchronous machine could be operated at power factor 1. The size of machine could be reduced, or the existing one could deliver higher active power, or for the same output, reduces its temperature rise and increases time life.

The VSI brings high virtual inertia to the unit, decoupling the machine from the grid, the pump-turbine could naturally operate on a stable manner, and the generator-motor rotor diameter and weight could be reduced.

FEATURES

- Deionized water cooled
- Modular concept
- Multi-levels output waveform
- Compliance with Grid Code
- Digital integrated protections
- Dedicated PWM patterns
- Each component is added with its associated gate driver
- A single Distribution Interface Board (DIB) fires all the IGBT and collects their return status

MV7 SERIES PULSE WIDTH MODULATION VOLTAGE SOURCE INVERTER

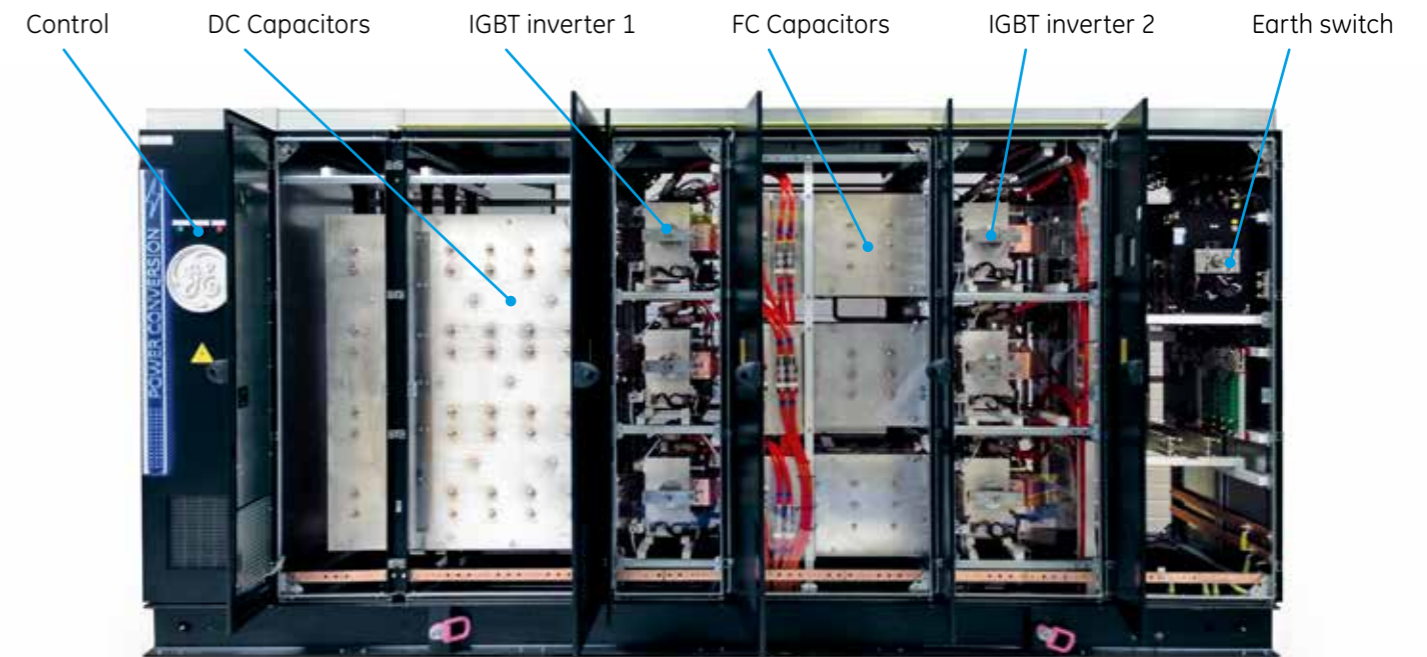

TECHNICAL DATA

- Power range: from 2 IGBT (3.3 kV–15 MW) to 8 IGBT (13.8 kV–37 MW)
- IGBT based voltage and current of each IGBT remaining the same

MV7000 RANGE OF MODULES ALLOWING TO BUILD UP CONVERTER TOPOLOGY UP TO 300 MW

VOLTAGE	FRAME	OUTPUT POWER		CURRENT	WIDTH	DEPTH	WEIGHT
3.3 KV	MV7306	6.4 MW	7.7 MVA	1,400 A	4,400 MM	1,000 MM	4.4 T
	MV7310	9.8 MW	12 MVA	2,100 A	4,800 MM	1,000 MM	4.6 T
	MV7312	12 MW	13.3 MVA	2,400 A	5,200 MM	1,000 MM	5 T
	MV7315	15 MW	16.7 MVA	2,600 A	6,000 MM	1,000 MM	6 T
6.6 KV	MV7616	16 MW	19 MVA	1,800 A	9,600 MM	1,200 MM	9 T
	U-W7618	18 MW	22.8 MVA	2,000 A	8,600 MM	1,400 MM	9 T
10 KV	MV7927	22 MW	27 MVA	1,800 A	10,200 MM	1,400 MM	10 T
	U-W7927	27 MW	33.7 MVA	2,000 A	11,000 MM	1,400 MM	11.5 T
13.8 KV	U-W7D40	37 MW	44 MVA	2,000 A	16,000 MM	1,600 MM	18 T

Control and Protection

For reliable variable speed operation

GE is transforming itself to become the world's premier digital industrial company, executing critical outcomes for our customers. Based on decades of experience in the energy and asset management sector, GE can help you to drive greater asset reliability, lower operating costs, reduce risk and accelerate operational performance with our platform and software solutions.

SPEED/POWER CONTROLLER SPMAX

SPMAX is a superimposed speed/power controller which helps to define set points for turbine and converter controllers for different operation modes.

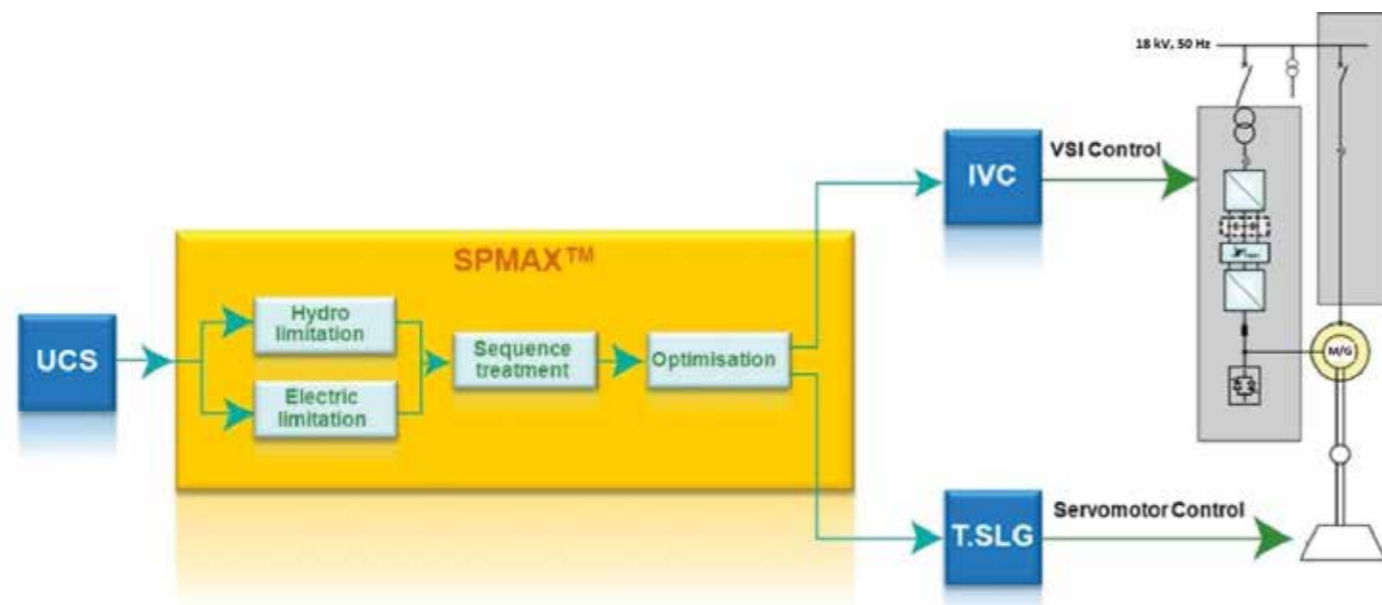

ROTOR GROUND FAULT PROTECTION SYSTEM

As a result of GE's network of researchers, scientists and engineers, GE is offering Rotor Ground Fault Protection System operating independently from the converter. It is an electrical protection relay designed and dedicated to operate with DFIM (doubly fed induction machine). It is suitable to operate at low frequencies.



Electrical Balance of Plant (eBOP)

Solutions for pumped storage power plants



MAJOR COMPONENTS OF THE EBOP FOR PSPP

- May include
- Control building with protection, control, metering and communications panels
 - Medium and High Voltage Switchgears
 - Statcom (DSVC)
 - Transformers
 - Generator Circuit Breaker Unit
 - MV Switchgears
 - Bus-ducts
 - LV Switchgears
 - Motor Control Center
 - Batteries
 - UPS Systems
 - Integrated SCADA system
 - Optional monitoring and diagnostic systems for transformers and breakers

MODULAR AND SCALABLE

Our solutions range from high voltage switchyard equipment to systems hardware and design and engineering services.

GE's engineering services capabilities include system studies, electrical, protection and control engineering, panel assembly and on-site installation and testing.

GE utilizes proprietary engineering tools to optimize the design and configuration of the collection circuits and provides turnkey SCADA solutions required for the plant operation and integration of the power plant into the grid, including the HMI for operation process supervision and controls with the option of remote control and diagnostics.

Our eBOP offering for PSPP applications is modular and scalable, meeting the specific requirements of developers, design institutes and energy utilities, ranging from power collection to grid interconnection consisting of substations and the transmission line connection to the utilities electrical network.

BENEFITS OF GE'S EBOP EQUIPMENT INTEGRATION

- Efficient and reliable equipment solutions, easy to operate and to maintain, which are designed to meet cavern ambient conditions
- One GE interface for efficient system planning, design and documentation
- Optimized configurations of reliable products, utilizing industry leading design tools for ease-of-integration in design, procurement and installation

Grid Integration & Consulting Services

Energy Consulting, grid analysis and power systems operation & planning

For over a century, the electrical grid has served its purpose, delivering power when and where it is needed. In recent years, several factors have converged that have heightened attention on the reliability and functionality of electric grids. Utilizing the power of software, power systems, machine learning, and other advanced analytics and next generation design and visualization techniques, GE is using its extensive knowledge of the grid to develop new solutions that will help utilities predict and prevent potential failures before they happen. GE's portfolio of power-grid-based technologies enables the use of real-time information to improve the operation of the grid. GE intermittency management and renewables integration technology also allow the grid to handle more renewable power without increasing wear and tear on utility equipment, while also enabling the efficient transfer of renewable power over long distances, helping to move power from sunny, windy areas to the places where people live

and work. Our dedicated expert group of engineers and business experts is specialized in complete power system analysis and simulation. Cross-business teams work to analyze and ensure the compliance of wind, solar and thermal power plant integration to the grid, keeping GE and its customers ahead of grid interconnection challenges.

The Global Power Projects team is made up of a core group of leading technical and business experts from GE who use cross-company resources to help you solve your most difficult challenges. Our team can help you with your renewables application issues, and we also can perform grid code testing of power generation equipment and sub-synchronous torsional interaction analysis and risk mitigation. Additionally, we have expertise in power system stabilizer application issues as well as utility IT and grid modernization projects.



Ancillary Services

Grid dispatch center

Ancillary services are specialty services and functions provided by the electric grid that facilitate and support the continuous flow of electricity so that supply will continually meet demand.

The term ancillary services is used to refer to a variety of operations beyond generation and transmission that are required to maintain grid stability and security, generally including frequency control, spinning reserves and operating reserves.

United States Federal Energy Regulatory Commission (FERC) FERC identifies six different kinds of ancillary services, i.e.

- Scheduling and dispatch
- Reactive power and voltage control
- Loss compensation
- Load following
- System protection
- Energy imbalance

Traditionally ancillary services have been provided by generators, however, the integration of intermittent generation and the development of smart grid technologies have initiated a change in the equipment that can be used to provide ancillary services.

OUR OFFERING

- Reactive power control
- High dynamic of frequency regulation in turbine and pump mode
- Compensate non predicted power variation thanks to fast power adaptability
- Grid stabilization in case of short-term grid power interruptions by machine inertia
- Black-start capability
- Adjustable power consumption in pumping mode

P/Q DIAGRAM

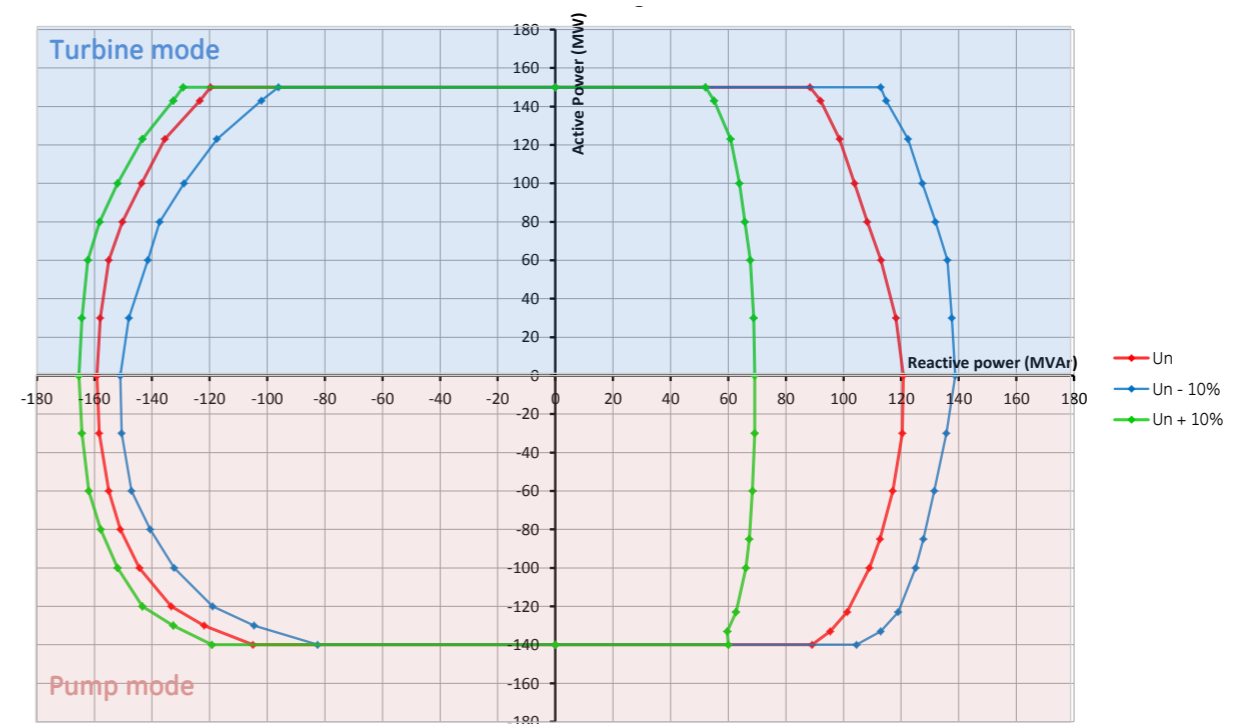

Modelling and Simulation Capability

For hydraulic, mechanical, electrical equipment and grid interaction

GE's engineering service capabilities include design and system studies, modelling and simulation of equipment and process life-cycle conditions, power and hydraulic flows, as well as grid interaction.

GE utilizes proprietary engineering tools to optimize the design and configuration of systems required for the plant operation and integration of the power plant into the grid.

OUR OFFERING (ELECTRICAL SIMULATION) GRID CODE COMPLIANCE

- Demonstrate Fault Ride Through (FRT) capability
- Compute voltage and current harmonic distortion levels
- Simulate frequency and voltage regulation capability

DYNAMIC RESPONSE OF COMPLETE UNIT SIMULATION

- Modelling of whole water to wire system, from penstock to high voltage switchyard
- Demonstrating dynamic power injection while respecting pressure limits in hydraulic circuit
- Simulation of fault currents for protection coordination

FULLY INTEGRATED SIMULATION

- Integration optimization of all hydraulic and electrical machines as well as converters, electrical balance of plant, electrical grid connection

COMPUTATION OF OPERATION MODE TRANSFER TIME

- Computation and optimization of transfer time between operation modes
- Early indication of transfer times between operation modes supports planning of grid service capabilities



Grid Initialization Controllers

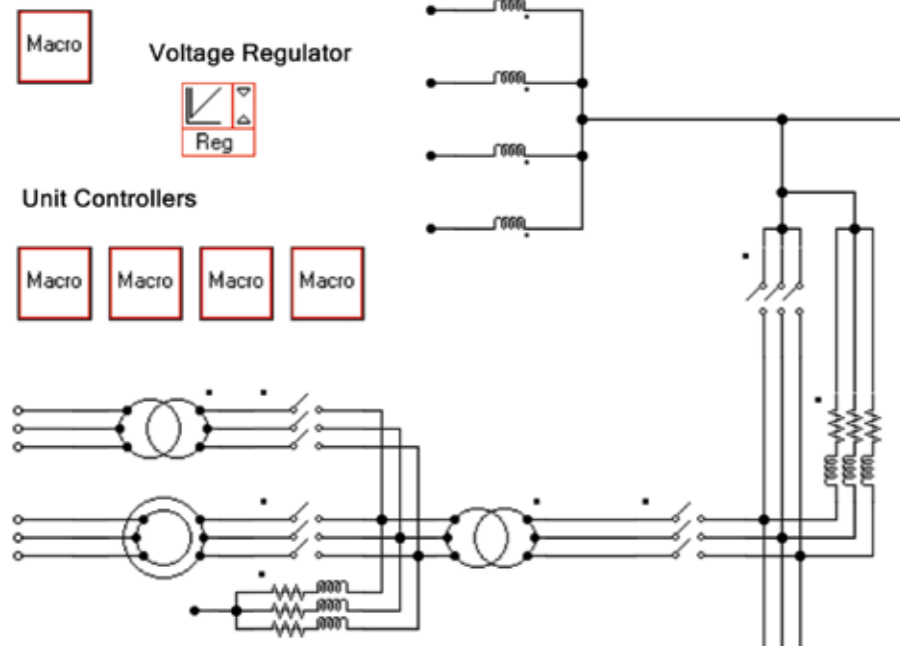

Hydro-Mechanical Equipment



Our R&D teams are continuously improving our products with research on high strength steels, head loss reduction, and fatigue and corrosion phenomena. In addition to our turbine and generator products, our scope for hydro-mechanical equipment includes:

- Onsite manufacturing
- Welding
- Steel grade determination and fatigue analysis
- Construction

WE OFFER:

- Radial gates, bulkhead gates, flap gates, fixed wheel gates, sliding gates, mitre gates, bottom outlet gates
- Penstocks
- Hollow jet valves
- Trash racks and trash rack cleaner machines
- Overhead travelling cranes and gantry cranes

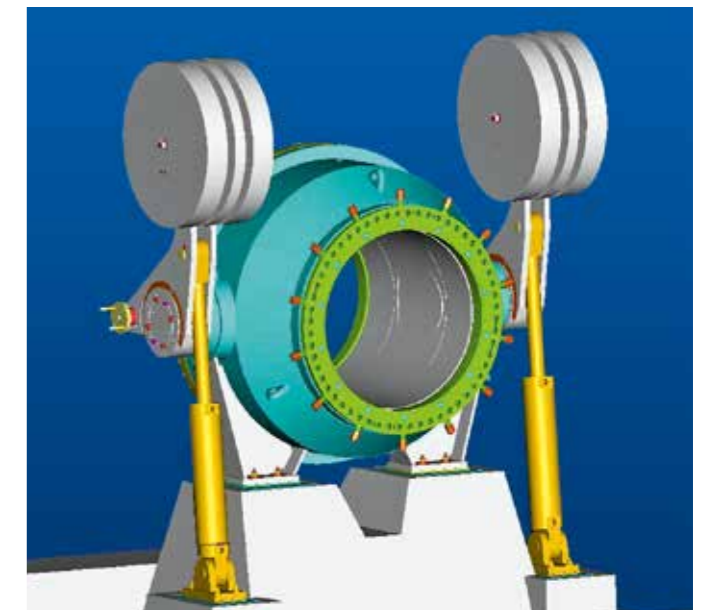

Spherical valve for PSP

Project Management

for One GE supply scope

GE's offers cover each step of your project, namely conceptual design, engineering, manufacturing of equipment, transportation and commissioning of the plant. We can accompany you from the very beginning of the project opportunity up to the handover of the commissioned plant. GE can look back on a rich experience in energy that allows a straight forward design and construction of your plant. From our perspective, experienced project managers are key to success – they coordinate the individual

contractors, perceive uprising challenges and manage them in a structured and well-organized manner. GE offers training sessions for your employees, either on-site or at its manufacturing facility. They are held by experts to comprehensively convey the service and maintenance concepts. GE is passionate about customer satisfaction in each and every product and service offered. Long term relationships are built with our customers by contributing to their success.

PHASES OF PROJECT MANAGEMENT

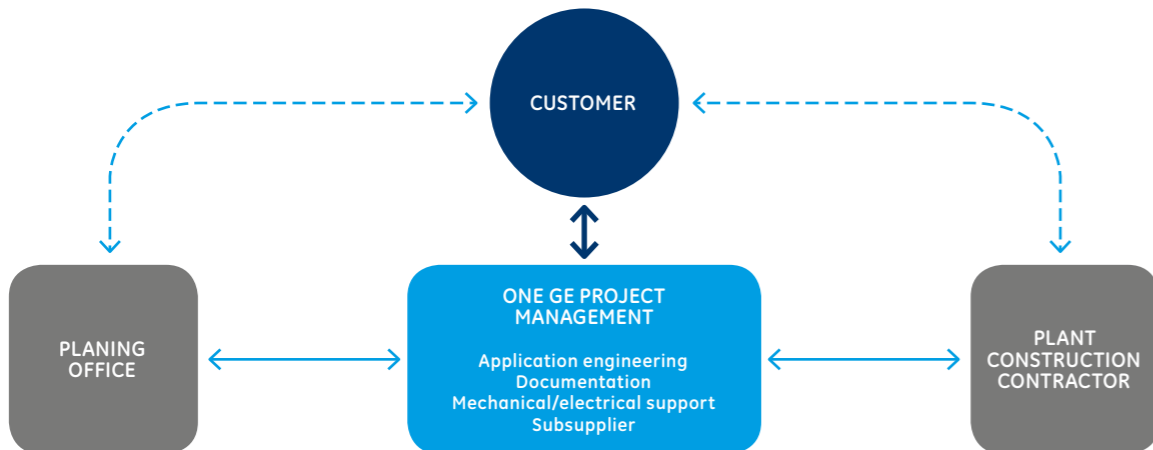
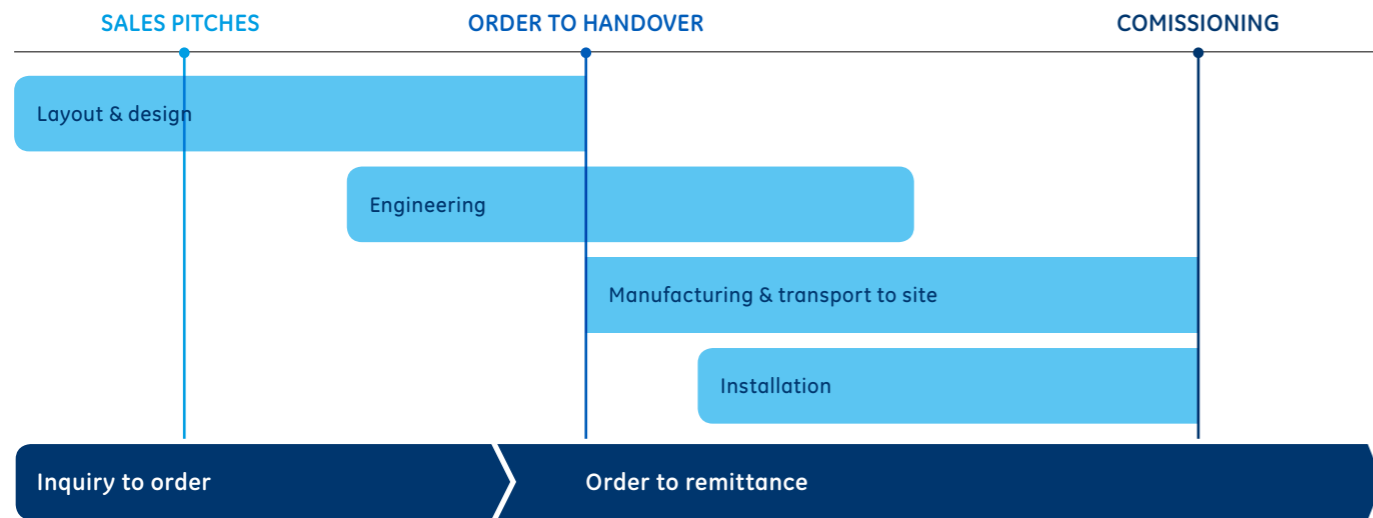

Project managers are key to a successful project by coordinating the individual stakeholders.

Global Partner with Local Footprint

Full line portfolio from day 1 to end of lifetime

GLOBAL FOOTPRINT TO OPTIMIZE LOGISTICS AND SERVICES COST

With the growing size of power generation equipment, logistic costs also become a larger piece of total cost. Therefore large power generation equipment is preferably manufactured close to the installation sites. GE has manufacturing locations around the globe and offers global and local service support to operate the equipment reliably and efficiently on the long-term. Our offering comprises the full line portfolio from day 1 to end of lifetime, service agreements from frame agreement to full O&M package, as well as retrofit with latest technologies.

SCALABLE MANUFACTURING CAPACITY AND LOCAL CONTENT

To support customers during the planning, design and execution of large hydro projects, GE has global manufacturing footprint. GE has capacity to meet the increasing need for power generating equipment in large dimensions as well as in large quantities.

Certain countries require local content manufacturing to satisfy regulations and support mechanisms. GE has capability to meet local content requirements, where needed.

WORLDWIDE MANUFACTURING LOCATIONS

- 8 GEPC Power electronics sites
- 5 GEPC Rotating Machines sites
- 9 GE Alstom Hydro sites

COMPLEMENTED BY A GLOBAL NETWORK

Our worldwide footprint is complemented by a global network of engineers, scientists, and researchers, energy consulting and financing services.

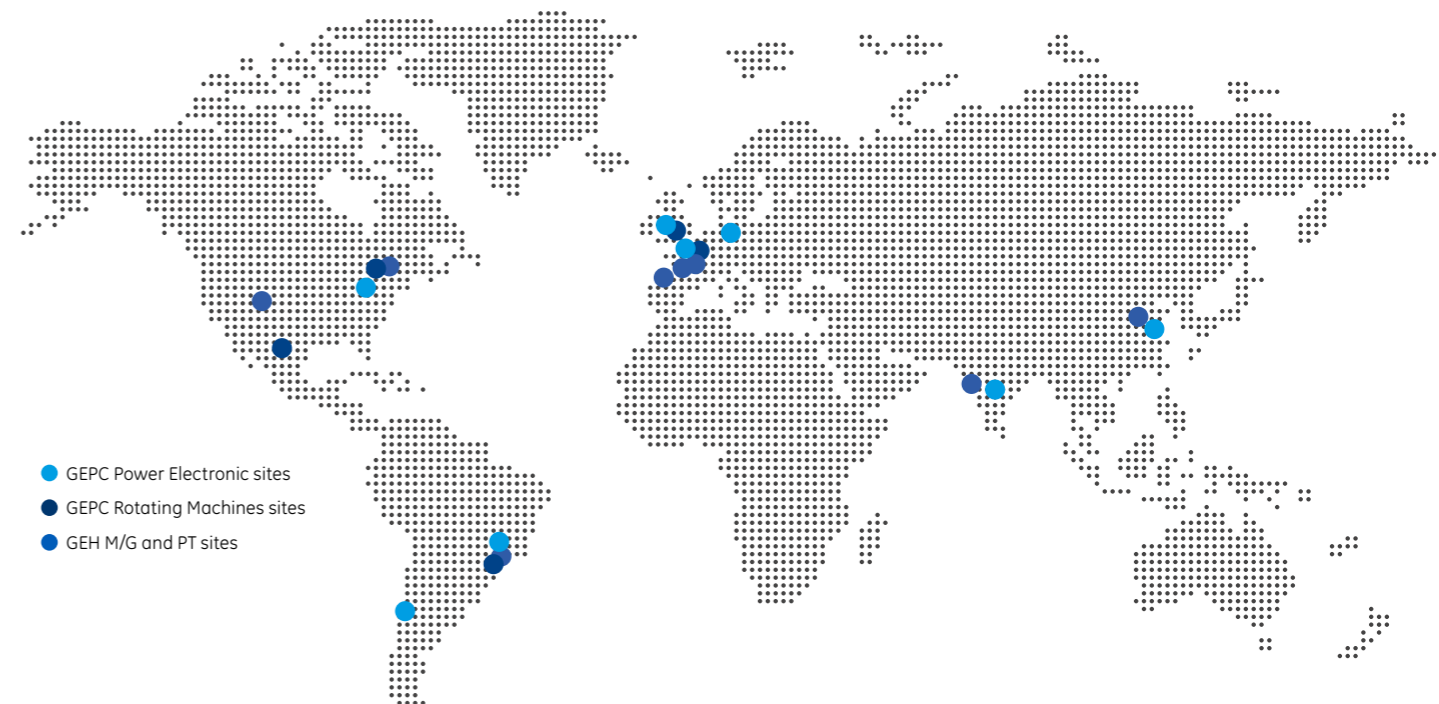

Servicing over the Life-Cycle of PSPP

100+ years of experience in servicing and modernizing power plants

Based on its comprehensive knowledge of all type of equipment and global fleet experience, component integration and interfacing, GE provides standardized and tailored solutions to maximize PSP availability & reliability, meeting business goals in flexibility and performance improvement.

GLOBAL TECHNOLOGY, LOCAL PRESENCE

GE's broad service portfolio in hydro operator's efforts in making their plants more competitive: meeting all Installed

Base challenging requirements, it covers all equipment, from commissioning to end of lifetime: Training, Parts, Diagnosis & Monitoring, Maintenance & Repairs, Service agreements, and Retrofit.

With over 1,000 Field Service Engineers operating in more than 170 countries and a range of Global Excellence Centers, GE supports customers with strong technology and engineering capabilities with quick access to experts.

SERVICES FOR HYDRO SYSTEMS

DIAGNOSIS & MONITORING

1 Day Outage Assessment

Evaluate components with high risks of failure to anticipate forced outage

Power plant performance depends on very complex interactions between all components and systems. Backed by an in-depth knowledge, GE's advanced monitoring and diagnosis methods provide evaluation and analysis with accurate data to better operate, maintain equipment and identify action plans.

UPGRADE KIT FOR PLANNED MAINTENANCE

Why wait for retrofit to get upgraded performances?

Upgraded solutions executed with a 'short implementation approach'

GE offers an extensive set of upgrade solutions with fast lead-time implementation: improvements matching major planned maintenance period, requiring no additional downtime, thus allowing operators to faster adapt their units to the changing market.

SERVICE AGREEMENTS

Get peace of mind

A flexible and secure way to provide high quality plant support and maintenance

From a frame agreement to a full O&M package, GE proposes tailor-made service agreements for the whole fleet, plant or any other type of equipment, meeting all customers' operational, maintenance and support requirements: flexible in scope of services – from training and technical support to emergency repairs, parts and assessment – equipment covered, as well as contract duration and risk sharing.

RETROFIT

Give your plant a second life

- Up to 30 % additional turbine output improvement thanks to upgrades
- Up to 5 % increase in runner efficiency (with same discharge) by using the latest design

Tailor-made solutions adapted to each plant specific needs, GE either replaces or reconditions major components in order to restore original performance levels, respond to new operating patterns, extend plant life and optimize plant layout, or to increase performances. GE customized solutions cover either single component or entire systems/plants (integrated, turnkey solutions) whatever the origin of their equipment.

Servicing over the Life-Cycle of PSPP

100+ years of experience in servicing and modernizing power plants



SERVICES FOR POWER ELECTRONIC SYSTEMS

ENHANCING ENERGY HARVEST ACROSS PROJECT LIFE-CYCLE

GE's services support continuous plant operation, enabling higher energy yield and therefore high return on investment across life-cycle. GE Services provide a broad range of activities that are necessary for utilities and power plant operators to protect assets, keep critical processes running, to help decreasing risk and enhancing productivity while the owner/operator concentrates on their core business.

FLEET DATA ANALYTICS AND PREDICTIVE MAINTENANCE

Through advanced digital platforms, we deliver expert onsite and remote 24/7 support, emergency interventions and all customized to meet unique customer requirements.

FROM "HELP ME FAST" TO "PARTNERSHIP"

We offer both on demand services and long term service contracts with a range of options from "Help Me Fast" to "Partnership" which creates a fully inclusive contract offering. Key elements of our customizable services offering for our power electronic systems in PSPP comprise:

- Remote monitoring & diagnostics
- Maintenance
- Spare parts & obsolescence management
- Factory repairs and overhauls
- Warranty extensions
- Response time guarantees
- Modernization and Upgrades
- Operation and Maintenance Trainings

Higher Output

Reduce Downtime

Lower Losses

Extend Lifetime

Our Success

50+ years of experience in PSCP across the globe

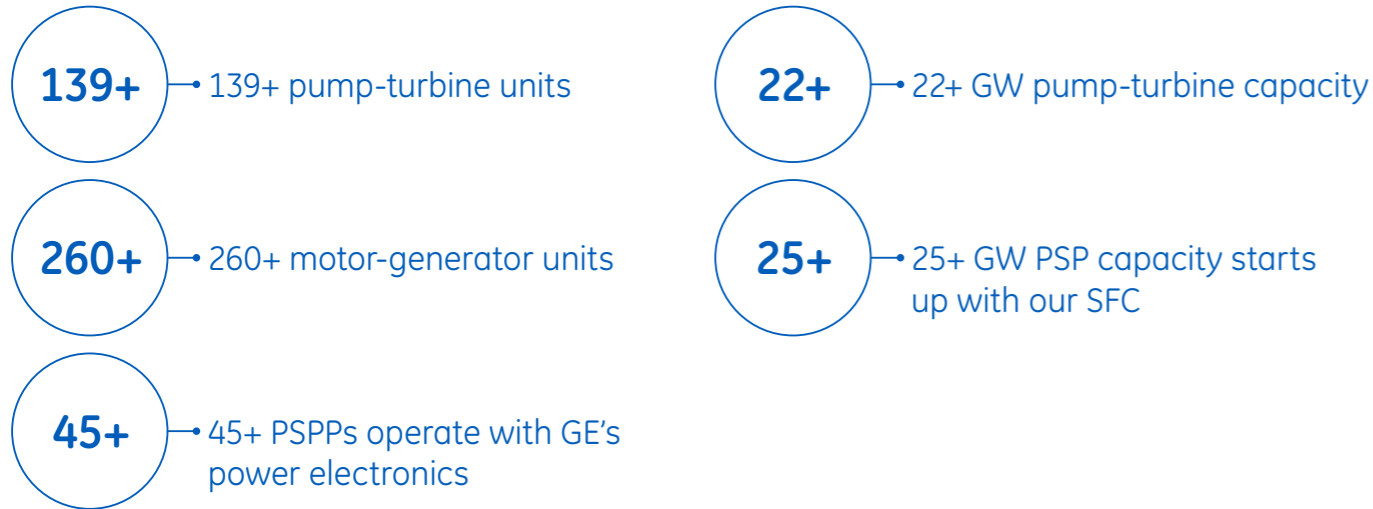

Contact Us

GE ENERGY CONNECTIONS | POWER CONVERSION

POWER CONVERSION HEADQUARTERS:
GE Energy Power Conversion France SAS
18, Avenue du Québec – ZA de Courtaboeuf
F-91140 Villebon-sur-Yvette
France

POWER CONVERSION Renewables CoE
GE Power Conversion GmbH
Culemeyerstrasse 1
D-12277 Berlin
Germany

GE Power Conversion Technology (Shanghai) Co., Ltd.
3468, Yuanjiang Road,
Minhang District,
Shanghai 201109,
P.R. China

www.gepowerconversion.com
renewables.powerconversion@ge.com

GE RENEWABLE ENERGY | HYDRO

GE Renewable Energy
No.237, Jinsan Road
Airport Economic Area
Tianjin 300300
P. R. China

GE Renewable Energy
3 Avenue André Malraux
92300 Levallois-Perrett
France

GE Renewable Energy
82, Avenue Léon Blum
38041 Grenoble
France

GE Renewable Energy
Hydro
Zentralstrasse 40
5242 Birr
Switzerland

 For more information about reference projects, please contact us for your specific request

The GE Store

DRIVING COMPETITIVE ADVANTAGE ACROSS OUR BUSINESSES

We drive enterprise advantages that benefit the entire company, through what we call the "GE Store". It means that every business in GE can share and access the same technology, markets, structure and intellect. No other company has the ability to transfer intellect and technology as we can through the GE Store.

