

Innovative Distribution Feeder Protection and Control Schemes Using New Capabilities of Microprocessor Relays

Mohammad Vaziri
PG&E

Farshid Vahedian Brojeni
PG&E

Eugene Shulman
GE Multilin

Manish Thakur
AEP

1. Abstract

Currently distribution feeder protection and control (P&C) schemes are designed using previous generation of the microprocessor relays, electromechanical switches, and separate annunciation and metering panels. The traditional design involves significant wiring and associated costs. Recent advancements in microprocessor relaying technology provide new features, which can replicate functionalities of conventional switches and annunciation & metering interfaces. Utilization of these new features in the modern relays can result in development of cost effective P&C schemes with significantly less wiring requirements.

This paper describes development of an innovative redundant protection and control schemes utilizing the state of the art features offered by the new microprocessor relays for distribution feeder application for one of the major utilities in the United States.

In the process of designing and implementing this new distribution P&C schemes, there were numerous challenges. Special consideration and efforts were extended to comply with the utility's philosophies in relay redundancy, reclosing practices, underfrequency load shedding, overfrequency restoration and protection against "single phasing" conditions in the fused bank applications.

The paper also discusses the operational experiences gained from the feeder installations employing this scheme, which validates the merits in the engineering approach as well as design and implementation.

2. Introduction

Modern economics are becoming increasingly dependent on reliable and secure electricity services and enforcing utilities to upgrade their distribution installations. The growing need for enhanced substation automation and integration system demands from utilities to renovate their distribution protection, control and automation schemes. Over the last decade, utility engineers have understood the benefits of digital multifunctional protective relays and extensively utilized those relays along with traditional switches, annunciation panels and panel board meters in new installations and in retrofits.

The technology advancement and better understanding of utility's growing requirements by relay manufactures led to development of the new generation microprocessor relays offering new elements and functionalities in the relay box.

These new elements/functions provide additional options to a P&C engineer in developing a fully integrated protection and control scheme.

The modern relay technology advancement and new reality of the deregulated energy market have set the stages for a step forward in substation integration and automation at PG&E. In line with this, the decision to develop a new universal Integrated Protection And Control (IPAC) standard for distribution feeders has become an important part of the distribution system renovation plan. The main business and technological goals of the IPAC standard for distribution feeders are summarized below:

- the reduction of the capital, maintenance and operating expenditures
- the need to improve system reliability and at the same time to decrease the service downtime for greater customer's satisfaction
- the need for breaker and protection & control systems monitoring. Use of the information stored in the relay for abnormal situations detection, systems troubleshooting and preventive maintenance
- the operating requirements for local and remote (via SCADA or EMS systems) monitoring, and trending of the steady state conditions such as system loads and voltages
- the engineering requirement for capturing the system currents, voltages and frequency waveforms during power system transient events. Non-volatile storage of this information in the convenient format for further analysis
- the requirement to increase the number of the digital and analog SCADA points collected from the IPAC system in order to decrease the field personnel workload
- the requirement to decrease the cost and at the same time to improve reliability of the SCADA system, which is associated with the reduction of the number of protective relays used, elimination of RTU's analogue transducers & digital I/Os, and elimination of the vendor specific protocol conversion equipment

3. System and Operations Requirements of IPAC Standard Scheme

The new IPAC scheme must comply with many requirements

established by the various utility services and departments. These requirements are based on various operational practices, engineering solutions and field experience. The summary of these requirements is listed below:

3.1 Set-A and Set-B Protection Relays

PG&E policy in regards to feeder protection requires the use of two multifunctional relays namely Set-A and Set-B, manufactured by two different relay vendors. The main reason for this requirement is to maintain the high level of the reliability and to reduce dependence of the overall IPAC scheme to a single manufacturer.

3.2 Redundant Protection

Both relays must include the basic protection functions in order to provide the sufficient redundancy in protective functions and reliable fault clearing of the most common types of the faults. These basic protection functions are as follows:

- a. phase instantaneous (50P) and time overcurrent elements (51P) with optional directional supervision (67P)
- b. residual ground instantaneous (50G) and time overcurrent elements (51G) with optional directional supervision
- c. phase overvoltage (59) and undervoltage elements (27)

The directional supervision of the above mentioned elements is required for fault direction discrimination and it is normally applicable for the feeders connected to generation facilities.

3.3 Enhanced Protection in Set-A Relay

As per utility regulations and system stability requirements, SET-A is equipped with additional protection and automatic restoration functions. These functions are listed below:

- a. automatic reclosing with variable number of shots, "reclose stall", and "stall removal" capabilities replicates the functionality of the existing utility standard recloser
- b. underfrequency Protection and Automatic Frequency System Restoration. These features are aimed to comply with Under Frequency Load Shedding (UFLS) and automatic service restoration schemes. The typical PG&E UFLS scheme is implemented inside the dedicated stand-alone frequency relay and presents the limited capability of setting the specific frequency levels operation and restoration time delays for the different feeders. Another disadvantage of the single frequency relay is a loss of function availability during maintenance and relay testing. The new distributed UFLS design is implemented independently in each feeder relay of the substation and allows for individual setting of the scheme parameters for each feeder. At the same time no separate frequency relay is required and the operation of UFLS is independent of the single relay failure
- c. Breaker Failure Protection (BFP). According to PG&E

protection requirements for distribution breakers, BFP is applied in a switchgear configuration only. The primary reason is that faults inside the switchgear where the space is very limited can cause substantial damage under breaker failure conditions. The switchgears are usually installed in "indoor" stations, where faults coupled with failed breakers can cause severe damage to the whole station. Switchgears are also being proposed and tested for "outdoor" stations. In some instances BFP may also be recommended and installed for open switchyard breakers depending on the breaker failure consequences

- d. Negative Sequence Overvoltage: PG&E standardizes the use of this function in the substations equipped with the fused distribution transformers. The blown fuse of the power transformer can cause the supply of the high level of the negative sequence voltage to the distribution system. The voltage unbalance can cause the severe overheating to the motor loads and tertiary windings of the power transformers. Thus the feeders exposed to the relatively high level of the negative sequence voltage of more than 14% are disconnected within 7 seconds per PG&E criteria. Traditionally each fused transformer is equipped with a single voltage unbalance relay. The new voltage unbalance scheme design allows to either integrate the existing voltage unbalance relay or to use the negative sequence overvoltage function of SET-A relay for each feeder, depending on the station configuration and availability of an existing voltage unbalance relay
- e. Direct Transfer Tripping: Interconnection of a distributed generation (DG) to the distribution feeder may require a transfer trip scheme. The IPAC scheme for distribution feeder should be capable to send a direct transfer trip command to a DG facility in case of the feeder protection tripping. This function should be supervised by the dedicated cut in/cut out virtual switch for enabling/disabling of this function locally and remotely in response to DG operational condition
- f. "Live Line" Blocking of Close & Reclose: The automatic reclosing and manual closing of the feeder with connected DG on it must be supervised by the line voltage while the feeder breaker is open. The feeder breaker closing will be blocked as long as line side potential is present

3.4 Enhanced Control in Set-A Relay

As per IPAC scheme requirements, the SET-A relay should provide local control capabilities and status indications for the following elements and features;

- a. Breaker manual trip and close commands
- b. Local/Remote control selector switch
- c. Ground Relay and Sensitive Ground Relay (if applicable). Cut in/Cut out. According to PG&E's switching practice the Ground Relay must be cut out during the switching operation of a normally "radial" feeder when the

switching results in a “paralleling” of different sources (or different transformers). This is to avoid ground relays maloperation due to excessive loading unbalances that can occur during the parallel operation. Once the parallel feeder is opened at one end, all ground relays are cut in

- d. Recloser Cut in /Cut out. Reclosing functions must be disabled during breaker maintenance
- e. SET-A and SET-B Cut in/Cut out. Relay is always cut out for relay maintenance and testing. The relay in cut-out mode maintains the complete functionality, but isolates the tripping and other important output circuits from the scheme. This arrangement allows conducting the relay checks while feeder is in service. The operation of these switches can be done only locally by operators or technicians
- f. setting group selector switch. In many instances, a breaker may be used as a substitute for other breakers. In such cases, alternate relay settings are often required. Instead of having to adjust the relay settings manually, it is possible to switch the new setting group with predetermined setpoints suitable for the new application. This operation helps to save considerable time and efforts in setting the relay and consequent new setpoints verification
- g. front panel alarms and status indications. Local alarms, status indicators, and targets have always existed inside the stations. In the new implementation of the switches, the switch position is indicated by the dedicated front panel LED versus the physical orientation of the switch handle in the mechanical switches applications. Local alarms and indicators are checked and recorded by the operators as soon as the operator enters the station. In many cases, remotely can be provided only per-group alarm indication, or sometimes single station alarm. For detailed alarm information the operator will have to visit the station and check the local annunciation. The new IPAC scheme provides very comprehensive system status information helping to promptly locate the problem and restore the service

3.5 Communication Interface Requirement

- a. SET- B provides the communication interface for the remote controls via SCADA. PG&E primary reason for having one set for local control and another set for remote control via SCADA is “demarcation”. This demarcation arrangement is required in order to simplify system troubleshooting, maintenance and operations
- b. Remote control of Set-A functions is executed via SCADA-Set-B communication link and Set-A - Set-B hardwired binary inputs-outputs links

3.6 SET-A and SET-B Relays Synchronous Separation

The status of the switches and setting group selectors inside

SET-A and SET-B relays must operate synchronously and must be properly coordinated in case of the relay failure, testing, or cycling of the relay DC control power. The consistency of the SET-A and SET-B virtual switches must be supervised by the appropriate alarm.

3.7 Equipment Integrity and Maintenance

Set-A provides equipment integrity detection and maintenance alarms such as:

- a. slow breaker operation
- b. trip circuitry failure alarm
- c. breaker contact wearing monitoring
- d. VT Fuse Failure detection

This information presents a reliable indication for equipment problems and provides the valuable information for optimum maintenance scheduling.

3.8 Multi-level Set Point Templates

The development of the multi-level setpoints schedules templates. The amount of the relay setpoint entries required for the standard application must be limited to the number, which utility planners are normally dealt with. So the basic level template is required to be developed to address the needs of the planners. For non-standard applications the comprehensive template is required. The comprehensive template must have provision for the simple activation of the optional functions and elements such as breaker failure protection, directional overcurrent protection, direct transfer trip option, etc.

3.9 Metering and Recording Requirements

Metering and recording requirements. PG&E requires to have the following data available locally and remotely via SCADA:

- a. per phase Load Currents and Bus Voltages. Momentary values and time trend records
- b. 3 Phase Real and Reactive Power. The momentary values of these parameters are used for operating purposes
- c. one Phase Line Voltage and live line indication while breaker is open. This parameter is required in the application with the generation facility
- d. per phase Maximum Demand Current
- e. breaker maintenance information such as operations counter, contacts wear estimate data
- f. time stamped events recorder
- g. fault events oscillography capable of capturing waveforms of the multiple events and storing the records of these events in the non-volatile memory

This information can address the needs of the various utility subdivisions such as operations, system planning, protection engineering, maintenance department, billing department and

so on. In the following section of the paper, capabilities of new generation microprocessor relays, which will be used in the development of IPAC standard in align with the above mentioned system and operations requirements, are described.

4. Capabilities of The New Generation of Microprocessor Relays

The previous generation of distribution feeder protection and control package provided a reasonable level of the protection and control integration. However almost all of the supplementary functions such as metering, cut-in/cut-outs, switches, breaker controls, indication lights and SCADA interface were implemented using the traditional devices and conventional selector switches. The example of the previous generation feeder panel is presented in Figure 1.

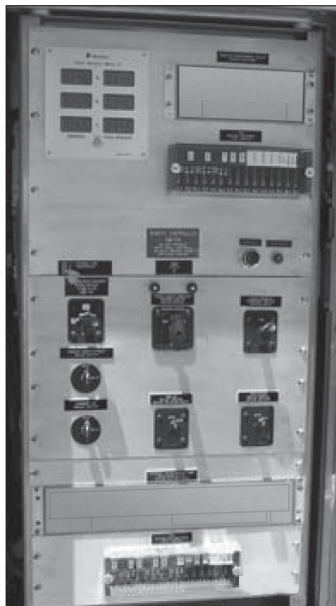

Fig 1.
Existing Standard Feeder Protection and Control Panel.

The technological progress and better understanding of customer's growing requirements by relay vendors led to the development of the innovative relay functionality integrated into one box. These new elements can contribute to the high level of the scheme customization and assist in developing a universal protection and control schemes.

The functionality review of the new elements is presented in this section.

Flexible Programming

The relay is equipped with the universal PLC-style programming tool, which can create the logical sequences required by any application. The logical operators, programmable timers, counters, latches, binary I/O and all the operands internally generated by the relay functions can be used as logic equation entries. A system of sequential operations allows any combination of specified operands to be assigned as inputs to specified operators to create an output. The specially designed logic editor presents a convenient way to compose the logic equations and to inspect the accuracy and the compliance to logic equation rules.

Flexible Protection Elements

These elements present universal comparators that can be used to monitor any analog actual value measured or calculated by the relay or a net difference of any two analog actual values of the same type. The effective operating signal could be treated as a signed number or its absolute value could be used as per user's choice. The element can be programmed to respond either to a signal level or to a rate-of-change (delta) over a pre-defined period of time. The output operand is asserted when the operating signal is higher than a threshold or lower than a threshold as defined per user's choice. Applications could include: positive/negative sequence overcurrent, negative sequence overvoltage, overpower, power factor, temperature differential, frequency rate-of-change etc.

User Programmable Push Buttons (UPPB)

Relay's Faceplate offers user programmable pushbuttons, which are intended to replace the traditional electromechanical switches and can be configured to replicate different types of switches. Each pushbutton can be configured as latched or self-reset.

It can provide the functionality allowing configuring the UPPB in the breaker control application required 2-step breaker control (Select-Before-Operate). In addition the configurable pushbutton LED and front panel display "smart" messaging accomplish the replication of the SCADA based secure breaker control. UPPB also provides the capability of the remote pushbutton control. Separate blocking of the UPPB remote and local controls supports the local/remote control selection.

Another UPPB application utilized in IPAC scheme provides the local and remote single pushbutton execution of the pulse-set/pulse-reset command; for example CUT-IN/CUT-OUT virtual switch. The detailed description of the UPPB can be found in the next section. The UPPB can be easily labeled for added clarity of functionality.

IPAC scheme pushbutton designation is presented in Figure 2

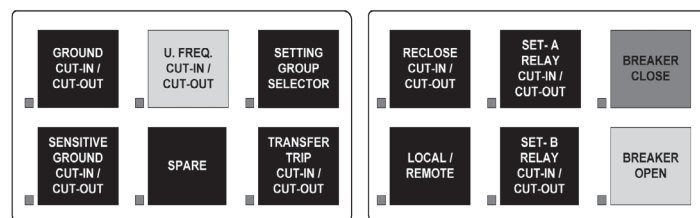

Fig 2.
User Programmable Pushbuttons Designation.

User Programmable LEDs

Relay's front panel is equipped with multiple LEDs which are typically used to provide the annunciation and indications of the functions included in the relay. Any LED can be freely assigned to any one of the operands generated by the relay internal functions or binary I/O's. These LED can conveniently replace the traditional panel stand-alone indication lights and annunciation devices. The LED can be configured as latched or self-reset. Additionally the LED blinking can be implemented using simple logic. These features compliment the complete replication of the typical annunciation panel functionality. The user programmable LED's can be easily labeled for clear

indication of the assigned function.

IPAC scheme user programmable LED's designation is presented in Figure 3.

User Programmable Non Volatile Latches

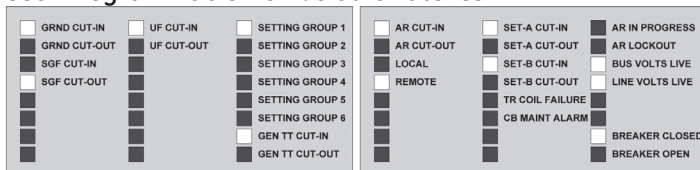

Fig 3.
User Programmable LED's Designation.

Virtual non-volatile latches provide two maintained logical states; set (1) and reset (0) and can be driven to these states by applying any of the operands generated in the relay. The maintained state of the latch is stored in the non-volatile memory and will be restored upon relay rebooting during control power cycling events. In order to sustain the state of the virtual latch even during no control power situations the latch can be assigned to drive the special bi-stable relay outputs. This concept is typically used for the logical implementation of the cut-in/cut-out switches, lockout relays or some other situations when the status of the latching function must be maintained even when the relay control power is down.

Because of the virtual nature of the latch it might be a case when both, the "set" and the "reset" commands are active at the same time. Hence the latch has an option to be configured as a "set" or "reset" dominant depending on the application requirements.

Configurable Selector Switch

Seven-position virtual selector switch is intended to replicate the mechanical counterpart.

The digital technology allows for enhancements in functionality and makes it universal.

The element provides for two control inputs. The step-up control allows stepping through selector position one step at a time with each pulse of the control input, such as user-programmable pushbutton or any other relay operand. The 3-bit control input allows setting the selector to the position defined by a 3-bit word.

The element allows pre-selecting a new position without applying it. The pre-selected position gets applied either after timeout or upon acknowledgement via separate inputs (user setting). The selector position is stored in non-volatile memory. There are 3 different restoration modes "upon relay reboot" available as settable options;

- restoration of the switch position stored in the non-volatile memory.
- synchronization of the switch position to the current 3-bit word.
- first try to synchronize the switch position to the current 3-bit word, but if this attempt is unsuccessful restore the switch position to the value stored in the non-volatile memory.

The SYNCH/RESTORE mode can be useful in some applications

where selector switch is employed to change the setting group in the redundant (2 relays) protection schemes.

Digital Counters

The universal bidirectional digital counters are capable of incrementing and decrementing the number of the stored pulses, starting to count from the preset value. The additional functional inputs can reset the counter to the preset value, block the counter operation, freeze the element at the current count and also provide the freeze removal command. The typical applications of this element are a breaker operations counter and a watt-hour meter.

Digital Timers

The universal digital timers provide the additional capabilities to the relay programmable logic. The wide setting range and possibility to integrate the pickup and drop-out time delays in the same timer provides the multiple applications options to this element.

Configurable contact inputs and contact outputs

The modular design of the relay allows for the selection of the number of the relay physical inputs and outputs per application requirements. Each input can be configured as a logical input to any internal relay function. The wide range of the input operational thresholds provides additional universality to this element.

Contact outputs can be assigned to respond to any generated inside the relay operand.

Various types of the contact outputs address the requirements of the different applications such as fast operation, high interrupting capability, use of the normally open or normally closed contacts, bi-stable relays, integrity supervision of the control circuits and trip current monitoring.



Fig 4.
New Feeder Protection and Control Panel Layout.

The local control of CI-CO switch is executed in a similar manner. In this case the command is initiated by SET-A user-programmable pushbutton. This command will be communicated to SET-B and will control the SET-A relay internal function. Status of CI-CO switch is indicated on the relay front plate user-programmable LED's panel. The feedback status of the function received from SET-B relay will be compared with CO-CI status in SET-A. In case of mismatch the discrepancy alarm will illuminate the designated front panel LED.

The functionality of this scheme during abnormal protection system conditions, such as relay failure, relay testing, relay power cycling, and relay restoration, have also been taken into consideration.

The following requirements were implemented in the logic in order to handle the abnormal situations:

1. If a relay fails or intentionally taken out of service, the out of service relay status must be communicated to the in-service relay in order to block commands issued by the abnormal relay and prevent accidental operation of the CI-CO function of the in-service relay.
2. If a relay cycles the control power, all the virtual CO-CI switches must be restored to the pre-fault states. All the commands issued by the rebooting relay must be ignored by the in-service relay.
3. Prior to restoration of a relay previously taken out of service for maintenance it is required to match manually all the states of the virtual switches to the states of the corresponding switches of "in-service" relay.
4. The duration of the switching command must be at least 50 milliseconds in order to prevent false operation of the function due to the contacts bouncing. This operation time delay is also utilized in the logic to block the incoming command issued by the partner relay during power loss event.

For example, let us consider the situation when the SET-B relay loses control power for 2 hours. During these 2 hours CI-CO switch of SET-A relay has been switched locally from the "cut-in" to the "cut-out" position.

The pre-failure status of the switch is "cut-in"; virtual non-volatile latches in both SET-A and SET-B relays are in "set" position. Contact output in SET-B, which is wired to SET-A digital input is energized, latching output in SET-A relay is in "set" position and hence the corresponding digital input of SET-B is "hot". When SET-B power drops down it removes relay control power and de-energizes all the relay output contacts, providing the "switch cut-out" command to the corresponding input of SET-A relay, but at the same time it provides the SET-B failure indication to SET-A relay. According to the special requirements execution of the CI-CO command is delayed, so that the "SET-B-failure" signal comes first and blocks execution of the CI-CO command. When power to SET-B has been restored, the relay starts to reboot and will restore all the memorized in the non volatile memory states of the logic parameters and contact outputs. Upon rebooting SET-B relay issues the cut-in command and communicates "SET-B OK" status to SET-A relay. But at the same time "SET-B OK" logic inside SET-A relay declares "SET-B OK" status with 0.5 seconds time delay, thus ignoring the false "CUT IN" command coming from SET-B relay. During these 500 milliseconds SET-B relay will acknowledge the new state of the CI-CO output as "cut-out" and will synchronize SET-B switch status to SET-A.

SET-B Failure is declared in SET-A relay based on the status of 3 SET-A digital inputs directly wired to SET-B outputs. If all 3 inputs are not energized SET-A relay logic assumes that setting group of SET-B relay is undefined or control power is down, hence SET-B relay is declared non operational. The diagram of SET-B FAIL/OK is presented in Figure 6.

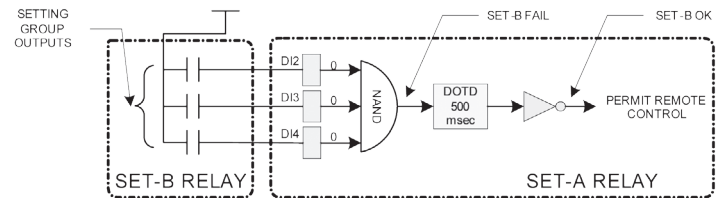

Fig 6. SET-B FAIL/OK Logic Diagram.

Setting Groups Synchronization

This application requires the use of the multiple setting groups and it is obvious that the setting groups in both relays must be synchronized as long as both relays are in service.

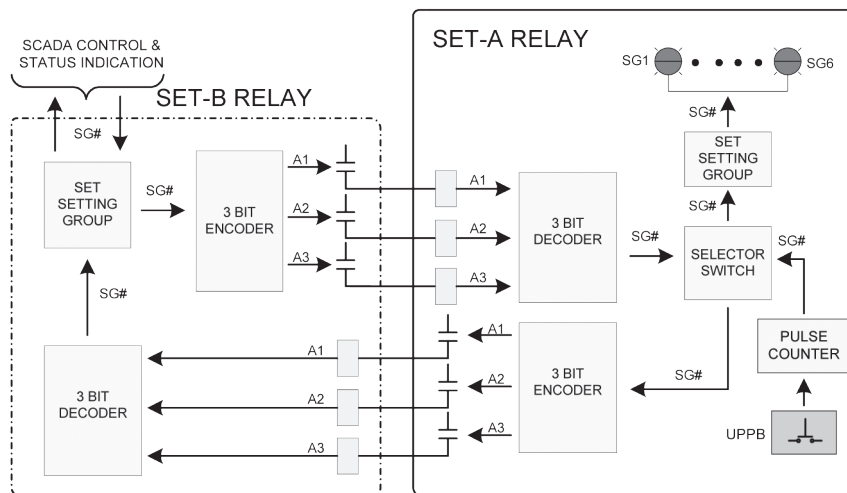

Fig 7. Setting Group Block Diagram.

Inputs / Outputs Status			Setting Group (SG#)
A1	A2	A3	
ON	OFF	OFF	Setting Group 1
OFF	ON	OFF	Setting Group 2
ON	ON	OFF	Setting Group 3
OFF	OFF	ON	Setting Group 4
ON	OFF	ON	Setting Group 5
OFF	ON	ON	Setting Group 6
OFF	OF	OF	No Change

Fig 8.
Setting Group Encoding Table.

The setting group change can be executed remotely, from SCADA or locally, from front panel pushbutton. The simplified setting group block diagram and the encoding table are presented in Figures 7 and 8 respectively.

Actually the setting group change logic is developed based on the virtual selector switch control element. Let us review the implementation of the setting group control in SET-A relay.

Selector switch element is configured in SET-A relay as a “6 maintained position switch”, where each position is used to activate the corresponding setting group in SET-A relay, and also used to transfer the setting group information via 3-bit decoder and a hardwired “output/input” interface to SET-B relay. This 3-bit information is encoded inside SET-B relay and activates the matching setting group in SET-B. Active setting group of SET-A relay is also indicated by front panel user programmable LED’s.

There are 2 methods available in IPAC scheme to select the new position of the virtual selector switch and consecutive setting group activation.

- the first method (Local Control) is to press the assigned user programmable pushbutton (UPPB). Number of times that UPPB was pressed with less than 5 second intervals between pulses is interpreted as number of Switch position operations and when 5 seconds of inactivity is expired SELECTOR SWITCH asserts the pre-selected position. In other words if the initial active Setting Group is # 1 and you press UPPB three times with 2 second intervals between operations the Setting Group 4 will become active 9 seconds after the first UPPB operation. All the interim SELECTOR SWITCH positions and the corresponding setting groups will be skipped
- the second method (Remote Control) is to apply a 3 bit external signal from the SET-B relay to SET-A relay. The selector switch position will be changed according to the decoded position number supported by the acknowledgment signal. The acknowledgment must come shortly (10-15 milliseconds) after any 3-bit activity coming out of SET-B relay. In this manner the almost simultaneous setting group change is insured in both relays during the remote setting group control. The acknowledgement signal is formed as any rising or falling edge of any of 3 inputs (3-bit signal). The exception is when all of the signals become “zeros”. In this case the setting group in SET-A relay will remain unchanged. The 3-bit control is supervised by status of SET-B relay and will be available only if SET-B relay is operational

The special logic is required to address the selector switch (setting group) behavior during relay power up or power down cycles. When power to the relay is applied or restored after control power loss the relay attempts to synchronize the setting group position to SET-B active group. But if all inputs coming from SET-B’s 3-bit outputs are 0, or SET-B relay is not in service, then SET-A will restore the last active setting group memorized in the non-volatile memory of the relay.

Autoreclose and Autorestitution.

Implementation of the application requirements of the autoreclose and frequency restoration logic presented some challenges. Even the comprehensive standard autoreclose function available in the relay couldn’t cover all the special features and details, required by the utility’s criteria. Use of the internal relay programmable logic elements helped to provide the high level of the autoreclose scheme customization and implement all mandatory and optional scheme requirements.

According to the system requirements automatic breaker closure may be performed due to any of the following system conditions:

- feeder restoration after the transient fault
- restoration after recovery of the system voltage to an acceptable level of balance and magnitude
- restoration after recovery of the system frequency to an acceptable level

The first two conditions are related to the multi-shot autoreclose (AR) function configured and customized in SET-A relay. The third condition is related to the frequency restoration logic, which is custom developed per utility specification and also placed in SET-A relay.

The initiation logic of the AR function is presented in Figure 9. The recloser is initiated each time breaker makes transition from closed to open state (52-B status). There are of course some exceptions (NOT AR TRIPS) for example; when breaker is tripped manually or in response to the underfrequency condition. The utility’s approach to declare the AR initiation (breaker open status, except some special conditions) differs from the concept offered by the relay’s standard autoreclose scheme. The standard autoreclose initiation is declared when breaker is closed (must condition) and initiation signal has been received.

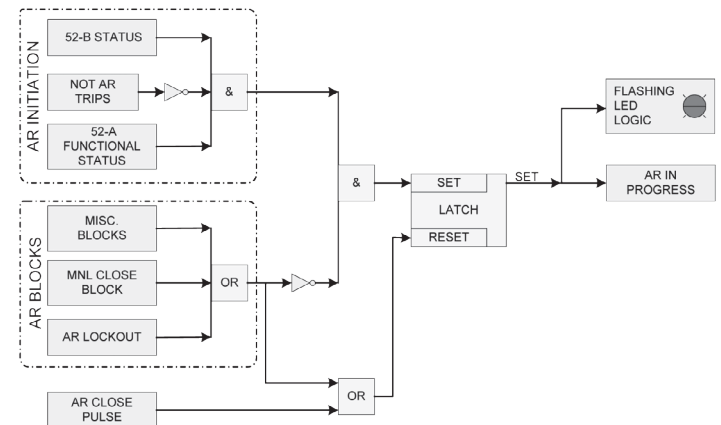

Fig 9.
Reclose Initiation Logic Diagram.

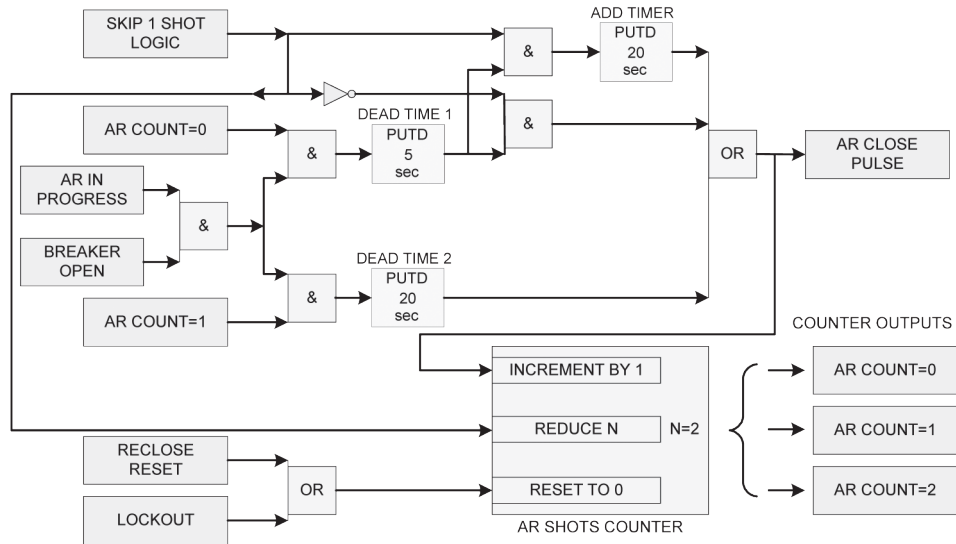

Fig 10.
Reclose Closing Logic Diagram

Thus autoreclose logic requires the functional “breaker closed” state to be defined. This state is implemented in programmable logic. For autoreclose logic, the breaker is declared closed when it is actually closed and 50 milliseconds after 52-a contact changes its state from closed to open.

Breaker is also declared closed (for autoreclose logic only) whenever breaker is open and previously applied AR stall condition has been removed.

AR initiation will be blocked if the reclose function is locked out, upon a “manual close” command or due to the other miscellaneous blocking functions such external blocking, abnormal voltage, operational cut-out of AR function and a few other conditions.

While reclose is initiated it will seal itself in the “in progress” mode. The flashing front panel LED provides a visual indication of the “AR in progress” status.

“AR in progress” will be reset whenever the AR issues the closing command or the reclose blocking of any kind becomes active. The simplified logic diagram of the AR closing logic is presented in Figure 10.

According to the utility’s criteria the recloser should have 2 closing shots with settable (usually 5 and 20 seconds) dead times respectively. For feeders with excessive fault duties the first reclosing shot may be omitted and only one reclose with

25 seconds time delay be executed.

The AR dead time timers will start to count down when the AR function is declared in progress and breaker is open. The active timer is selected based on the AR counter accumulation status.

If the counter accumulation status is equal to 0 then the “DEAD TIME 1” timer which is responsible for the first shot will start counting down. If the counter accumulation is equal to 1, indicating an unsuccessful first reclosing shot then the “DEAD TIME 2” timer which is responsible for the second shot will start counting down.

If the counter accumulation is equal to 2, or in other words counter reaches its maximum accumulation, then AR logic applies the “lockout” and prevents any further AR operation. Maximum accumulation of the counter can be also reached at AR COUNT equal to 1 in the situation with high fault duty, where the first AR shot is skipped. The same signal also reduces the maximum level of the “number of the shots” counter in order to accomplish the adequate functionality of the whole standard reclosing scheme.

If the reclose cycle is successful and the feeder is back in service, the reclose function will “reset” and become available for the new cycle, 65 seconds after the successful breaker closure.

If the reclose cycle is not successful and the breaker remains tripped after the last available shot the reclose function will

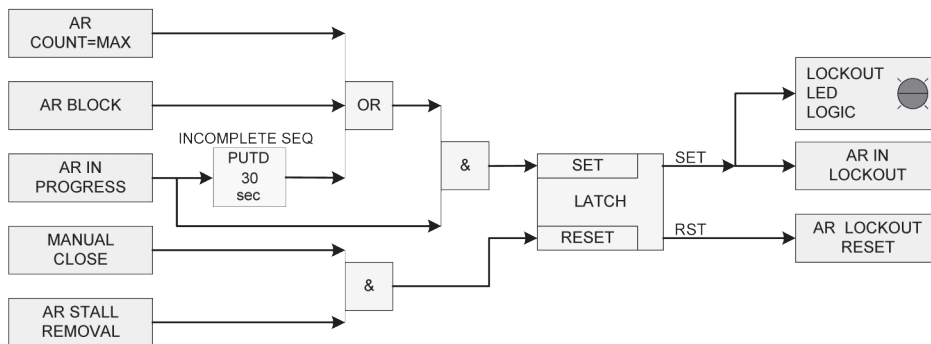

Fig 11.
Reclose Lockout Logic Diagram.

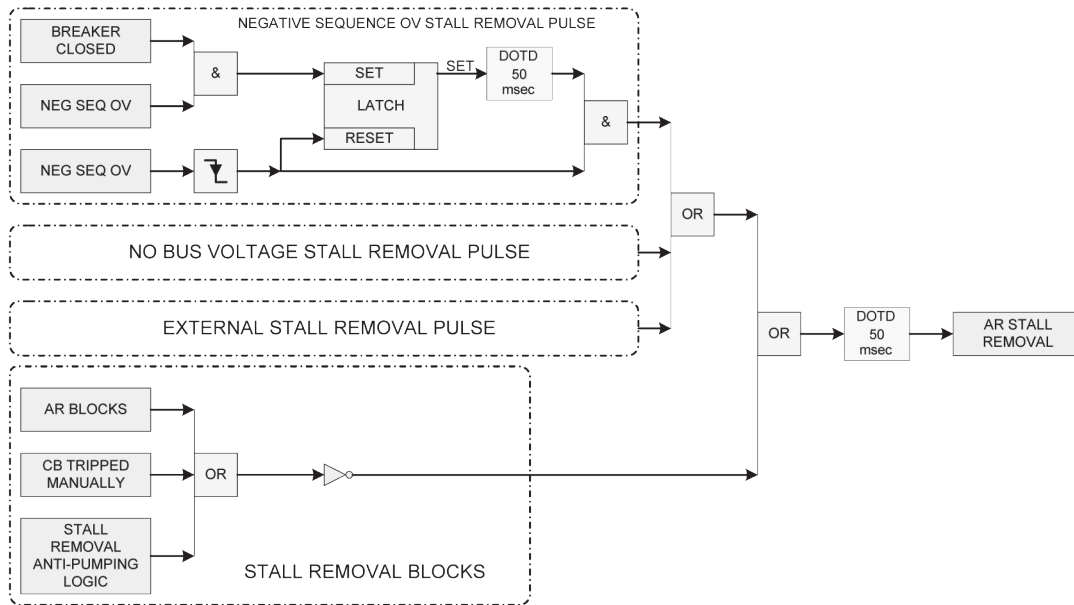

Fig 12.
Reclose Stall Removal Logic Diagram.

go into “lockout” and will remain locked out until the feeder is closed manually. The simplified AR lockout logic is presented in Figure 11.

According to this diagram the AR “lockout” can be applied only during the reclose cycle (Reclose in progress status). It can also be applied when the “reclose” function attempts to proceed to the next shot, due to an unsuccessful “reclose” attempt, where the maximum number of shots has been reached. The AR “lockout” will be applied if the blocking signal of any kind becomes active while reclose is in progress. Another cause for AR “lockout” is the incomplete sequence, when the AR “in progress” status remains active longer than the “DEAD TIME” setting. In our application the incomplete sequence is set to 30 seconds.

There are two methods available to reset an AR “lockout” condition:

- manual close (see Fig 11.)
- lockout reset upon stall removal

According to the utility requirements the developed AR scheme must support the reclose stall feature. This feature must temporarily disable the “reclose” function due to some abnormal system conditions such as:

- “no bus voltage” condition, presumably because of the upstream reclosing operation
- negative sequence overvoltage condition, presumably because of the power system loss of any phase situation

When the condition causing the reclose stall has been restored to normal due to successful upstream reclose in case of “no bus voltage” stall or due to high voltage side transformer fuse replacement in case of negative sequence overvoltage stall, then the reclose full cycle will be resumed

Figure 12 demonstrates the simplified logic of the stall removal mechanism. It is very important to ensure that the reclose stall is removed only from the same system condition that it was

applied. The same “apply-remove” logic blocks are presented for all system conditions configured to stall the recloser. The stall removal is inhibited if AR function is blocked or the feeder breaker has been opened manually. The stall removal “anti-pumping” feature provides one time operation in order to prevent multiple “apply-remove” actions due to some unstable system conditions or sensing device failure. The designated logical timer determines the minimum time between 2 consecutive “stall removal” operations.

Overfrequency Automatic Closing

The described feeder protection and control scheme provides an automatic restoration capability after underfrequency tripping events. There are two different overfrequency restoration levels are implemented in the scheme:

- frequency overshoot; this level is developed to address the situations when the frequency is restored to the level well above the rated system frequency of 60Hz. In this case in order to maintain the system load-generation balance a high speed breaker closing is required
- overfrequency restoration; this level is developed to address the situations when the frequency is partially restored

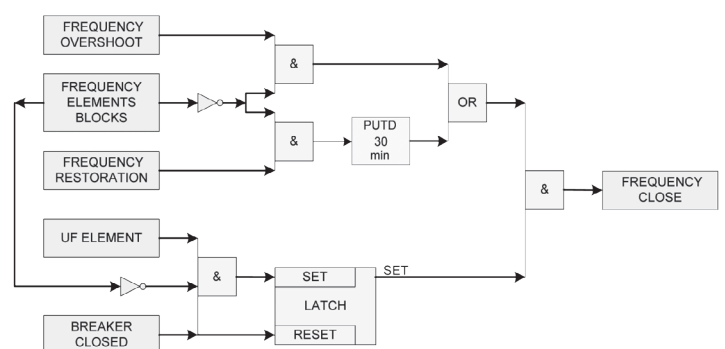

Fig 13.
Overfrequency Automatic Closing Logic Diagram.

to the level slightly below the rated system frequency of 60Hz. In such case, the restoration time delay is in the order of minutes and it is determined by the power system frequency event recovery plan

The simplified logic diagram of the Overfrequency Automatic Closing is presented in Figure 13.

The frequency restoration scheme becomes operational only if it was previously armed by the underfrequency event. The underfrequency arming is supervised by the closed status of the breaker in order to prevent an inadvertent automatic closing of the feeder breaker, which was intentionally left open. All the frequency elements are supervised by the relevant blocks such as relay cut-out status, frequency cut-out status, low voltage condition, etc.

Slow Breaker Maintenance Tool

Based on the utility's request, a "Slow Breaker" detection logic to be used as a breaker maintenance tool, was programmed in the relay and implemented in the scheme.

This tool is intended to verify the main breaker contacts travel time during the breaker "close" and "open" operations and to compare this time to the reference breaker operation times. If the actual operation time exceeds the reference time then the slow breaker condition will be declared and the corresponding alarm is communicated to the local and remote interfaces.

The breaker status is declared open if no current is detected in all 3 phases and the auxiliary breaker contact 52-B is closed.

The breaker status is declared closed if current is detected in all 3 phases and the auxiliary breaker contact 52-A is closed.

This scheme provides the correct results during on-load breaker operation but it is not always reliable for detection of a slow breaker during unloaded feeder breaker operations.

The self-explanatory simplified logic diagram of the slow breaker tool is presented in Figure 14.

6. Conclusions

The new state of the art Integrated Protection And Control (IPAC) design has been developed as a joint effort of the distribution engineers and P&C experts from relay vendors and the Pacific Gas and Electric (PG&E). The IPAC design offers universal and reliable distribution protection and control solution to PG&E with a potential for substantial future cost savings. Additionally, the IPAC design is convenient to operate, useful for preventive maintenance and easy to troubleshoot.

The IPAC design for distribution feeders considered all of PG&E's technical requirements. The successful implementation of IPAC design has established a new utility standard for multiple installations of the switchyard distribution feeders within PG&E.

The key benefits of the innovative IPAC design are listed below:

1. Improved reliability and security as two independent sets of microprocessor relays from two different manufacturers are used.
2. Cost effective solution as many traditional protection and control functions such as Breaker Failure Protection (BFP), and traditional switches, auxiliary relays, metering devices are integrated in the same relay box.
3. More flexibility in relay settings/programming and in selectivity of the feeders to be tripped. Examples:
 - a. Implementation of Under Frequency Load Shedding (UFLS) and the Automatic Frequency Recovery Restoration schemes on SET-A relay for each individual feeder as compared to centralized implementation of this scheme in one single relay in traditional design
 - b. Implementation of Negative Sequence Overvoltage scheme for detection of single phasing conditions of fused distribution transformers within each relay as compared to centralized implementation of this scheme in one single relay in traditional design

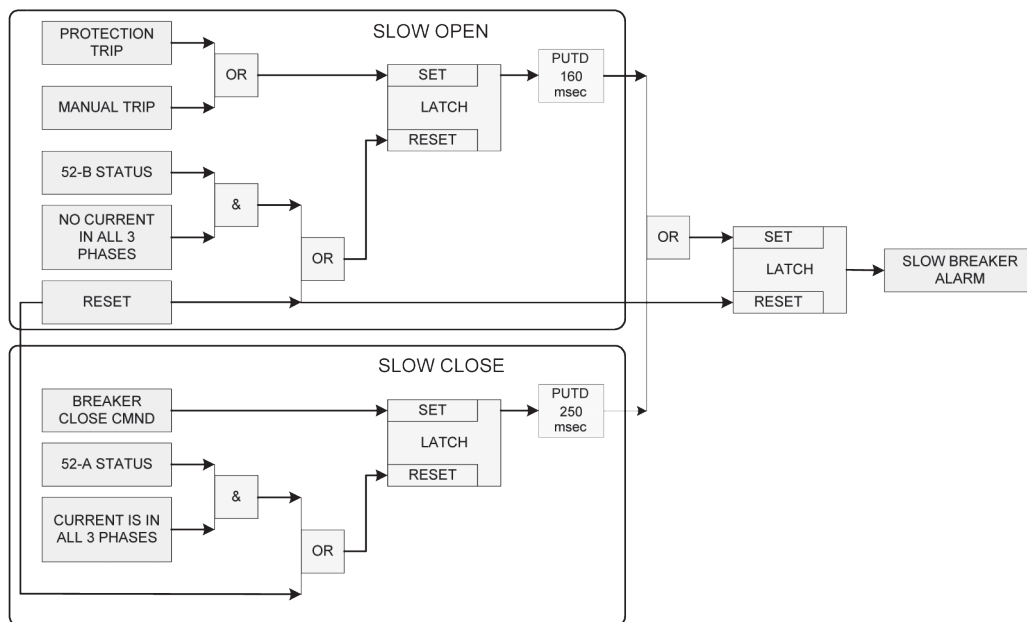

Fig 14. Slow Breaker Detection Logic Diagram.

- c. Provisions for Direct Transfer Trip and Reclose Blocking features. Reclose Blocking function will be installed on every feeder as a standard feature in anticipation of future Distributed Generation (DG) interconnections
 - d. Development of new monitoring features such as the "Slow Breaker" Maintenance Tool
4. Additional cost savings, as all required data recording, metering, and event information have been implanted within both microprocessor relays with local and remote retrieval capabilities.
 5. Standardized solutions such as universal multilevel relay templates to facilitate relay setting calculations and error checking.

Despite the fact that many of the challenges to accomplish harmonious functionality of all features between two independent sets of relays have been successfully resolved, new challenges and concerns are recognized as the field experience is gained with the new design. Scheme behavior concerns about issues such as; DC Voltage fluctuations, relay contacts de-bounce timing, and field personnel/operator intervention could be of interest for further investigation and monitoring by utilities and relay manufactures.

Since the successful introduction of this IPAC design, many of the new and retrofit feeder installations have been upgraded to the new standard, and they are successfully operating and providing a reliable and secure service to the thousands of PG&E customers.

7. References

- [1] IEEE guide for automatic reclosing of line circuit breakers for AC distribution and transmission lines. IEEE Std C37.104-2002
- [2] F60 Feeder Management Relay. Instruction Manual. Revision 4.9. GE Publication GEK-113206 (1601-0093-M1), 2006
- [3] SEL-351-5, -6, -7 Directional Overcurrent & Reclosing Relay. Instruction Manual. Publication # 20050518
- [4] M. P. Pozzuoli "The Universal Relay. The Engine For Substation Automation" GE Publication GER-3995, 1998
- [5] W.C New "Load Shedding, Load Restoration and Generator Protection Using Solid-state and Electromechanical Underfrequency Relays" GE Publication GET-6449