

# Fundamentals of Adaptive Protection of Large Capacitor Banks

Bogdan Kasztenny  
GE Multilin

Joe Schaefer  
Florida Power & Light Company

Ed Clark  
Florida Power & Light Company

---

## 1. Introduction

Shunt Capacitor Banks (SCB) are installed to provide capacitive reactive compensation and power factor correction. The use of SCBs has increased because they are relatively inexpensive, easy and quick to install, and can be deployed virtually anywhere in the grid. SCB installations have other beneficial effects on the system such as improvement of the voltage profile, better voltage regulation (if they were adequately designed), reduction of losses and reduction or postponement of investments in the transmission and generation capacity.

The role of SCBs increased recently in the light of blackout prevention activities, and increasing penetration of distributed generation, wind farms in particular, which add generation without addressing the problem of reactive power support. Moreover, capacitor banks are valuable assets that must be available for the daily demands of system operation and must provide reliable operation through abnormal power system scenarios.

From the protective relaying perspective, however, capacitor banks are historically considered a relatively low-volume market, and therefore, did not encourage development of advanced protective relays dedicated to capacitor banks. Quite often protection for SCBs is provided by general-purpose multi-function relays, with only a very few products on the market offering protection functions specifically tailored to capacitor bank protection. The utility relay engineer has generally needed to combine the functionality of multiple relays and customize their programming to provide the necessary protective system that will avoid false tripping for system disturbances and obtain the sensitivity for detecting capacitor CAN faults and minimizing damage.

The SCBs are assembled out of individual cans that are highly repairable. The need for advanced protection functions is particularly visible when SCBs are operated under conditions where one or more capacitor cans are temporarily removed but the bank is returned to service pending completion of repairs. However, continuous operation and repairs if needed can be done only if the bank is protected by a reliable and sensitive relay. This in turn, can be accomplished by deploying protection principles that are developed assuming an inherent unbalance in the protected bank.

Presently, in many custom applications or even dedicated capacitor bank protection products, compensation for inherent unbalance is based on subtracting historical values from the operating quantities, and thus making the relay respond to incremental, "delta" signals.

This paper will show that such simplified approaches are not optimal. Instead this paper derives technically accurate operating equations for capacitor bank protection that are derived assuming both inherent capacitor bank and system unbalance.

It is important that the relay is capable of dynamically compensating for unbalances between the power system phase voltages. These differences are constantly changing and may be on the order of 2 percent or more under normal conditions, and tens of percent during major system events such as close-in faults. The presented protection methods allow compensating simultaneously for the bank inherent unbalance and system unbalance increasing both sensitivity and security of protection.

The presented methods also facilitate auto-setting and self-tuning applications. Auto-setting is an operation of calculating new accurate relay constants to account for the inherent bank unbalances following the bank repair, and is performed in response to the user's request and under user supervision. Self-tuning is an operation of constantly self-adjusting the balancing constants in order to maintain optimum sensitivity of protection when the bank reactances change slowly in response to seasonal temperature variations and other conditions. The self-tuning applications require monitoring the total changes in the balancing constants in order to detect slow failure modes, and account for a series of small changes that do not trigger alarms on their own.

## 2. Capacitors

Protection engineering for shunt capacitor banks requires knowledge of the capabilities and limitations of the capacitor unit and associated electrical equipment including individual capacitor unit, bank switching devices, fuses, location and type of voltage and current instrument transformers.

A capacitor unit, Figure 1, is the building block of any SCB. The capacitor unit is made up of individual capacitor elements, arranged in parallel/series connected groups, within a steel enclosure. The internal discharge device is a resistor that reduces the unit residual voltage allowing switching the banks back after removing it from service. Capacitor units are available in a variety of voltage ratings (240V to 25kV) and sizes (2.5kVAR to about 1000kVAR).

The capacitor unit protection is based on the capacitor element failing in a shorted mode. A failure in the capacitor element dielectric causes the foils to weld together and short circuits the other capacitor elements connected in parallel in the same group, refer to Figure 1. The remaining series capacitor elements in the unit remain in service with a higher voltage across each of them and an increased capacitor can current. If a second element fails the process repeats itself resulting in an even higher voltage for the remaining elements.

There are generally four types of the capacitor unit designs to consider.

### 2.1 Externally Fused Capacitors

An individual fuse, externally mounted between the capacitor unit and the capacitor bank fuse bus, protects each capacitor unit. The capacitor unit can be designed for a relatively high voltage because the external fuse is capable of interrupting a high-voltage fault. However, the kilovar rating of the individual capacitor unit is usually smaller because a minimum number of parallel units are required to allow the bank to remain in service with a capacitor can out of service. A SCB using fused capacitors is configured using one or more series groups of parallel-connected capacitor units per phase, as shown in Figure 2.

### 2.2 Internally Fused Capacitors

Each capacitor element is fused inside the capacitor unit. A “simplified” fuse is a piece of wire sized to melt under the fault current, and encapsulated in a wrapper able to withstand the heat produced by the arc during the current interruption. Upon the capacitor failure, the fuse removes the affected element only. The other elements, connected in parallel in the same group, remain in service but with a slightly higher voltage across them.

Figure 3 illustrates a typical capacitor bank utilizing internally fused capacitor units. In general, banks employing internally

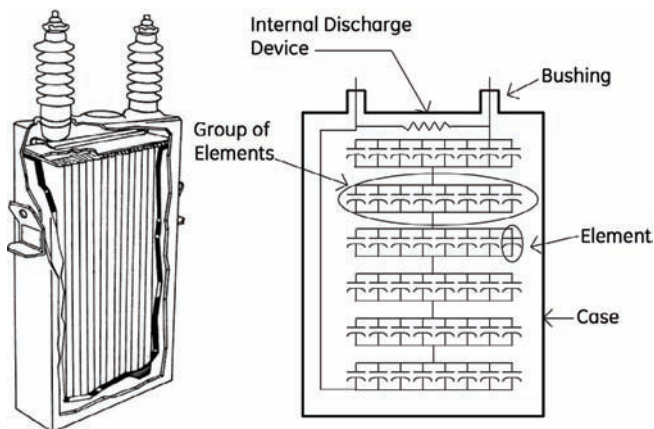

Figure 1.  
Capacitor unit.

fused capacitor units are configured with fewer capacitor units in parallel, and more series groups of units than are used in banks employing externally fused capacitor units. The capacitor units are built larger because the entire unit is not expected to fail.

### 2.3 Fuseless Capacitors

Fuseless Capacitor Bank designs are typically the most prevalent designs in modern day. The capacitor units for fuseless capacitor banks are connected in series strings between phase and neutral, as shown in Figure 4. The higher the voltage for the bank, the more capacitor elements in series.

The expected failure of the capacitor unit element is a short circuit, where the remaining capacitor elements will absorb the additional voltage. For example, if there are 6 capacitor units in series and each unit has 8 element groups in series there is a total of 48 element groups in the string. If one capacitor element fails, this element is shorted and the voltage across the remaining elements is 48/47 of the previous value, or about 2% higher. The capacitor bank remains in service; however, successive failures of elements would aggravate the problem and eventually lead to the removal of the bank.

The fuseless design is usually applied for applications at or above 34.5kV where each string has more than 10 elements in series to ensure the remaining elements do not exceed 110% rating if an element in the string shorts.

### 2.4 Unfused Capacitors

Contrary to the fuseless configuration, where the units are connected in series, the unfused shunt capacitor bank uses a series/parallel connection of the capacitor units. The unfused approach would normally be used on banks below 34.5kV, where series strings of capacitor units are not practical, or on higher voltage banks with modest parallel energy. This design does not require as many capacitor units in parallel as an externally fused bank.

## 3. Configurations of Shunt Capacitor Banks

Protection of shunt capacitor banks requires an understanding of the basics of capacitor bank design and capacitor unit

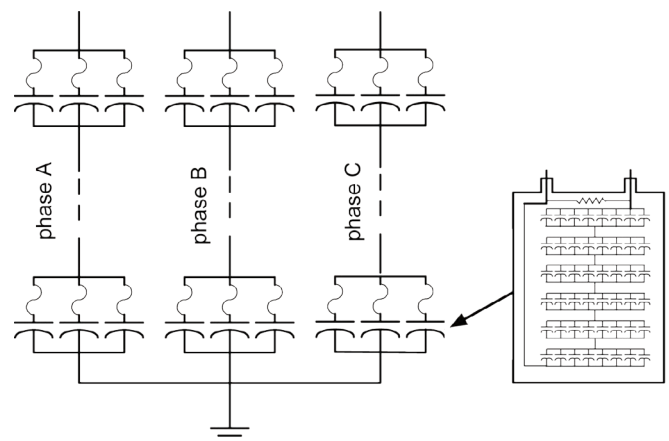

Figure 2.  
Externally fused shunt capacitor bank and capacitor unit.

connections. As a general rule, the minimum number of units connected in parallel is such that isolation of one capacitor unit in a group should not cause a voltage unbalance sufficient to place more than 110% of rated voltage on the remaining capacitors of the group. Equally, the minimum number of series connected groups is that in which the complete bypass of the group does not subject the other capacitors remaining in service to a permanent overvoltage of more than 110%. The value of 110% is the maximum continuous overvoltage capability of capacitor units as per IEEE Std 18-1992.

The maximum number of capacitor units that may be placed in parallel per group is governed by a different consideration. When a capacitor bank unit fails, other capacitors in the same parallel group contain some amount of charge. This charge will drain off as a high frequency transient current that flows through the failed capacitor unit. The capacitor can fuse holder, when used, and the failed capacitor unit must withstand this discharge transient.

The discharge transient from a large number of paralleled capacitors can be severe enough to rupture the failed capacitor unit or explode a fuse holder, which may damage adjacent units and even cause a major bus fault within the bank. To minimize the probability of failure of the explosion of the fuse holder, or rupture of the capacitor case, or both, the standards impose a limit to the total maximum energy stored in a parallel-connected group to 4650 kVAR. In order not to violate this limit, more capacitor groups of a lower voltage rating connected in series (with fewer units in parallel per group) may be a suitable solution. However, this may reduce sensitivity of applied unbalance detection schemes. Splitting the bank into two sections as a double wye may be the preferred solution, and may allow for better unbalance detection scheme.

Two prevalent designs of SCBs are the externally fused bank and the fuseless bank. There are advantages to each design.

Externally fused banks typically have a higher unbalance current when a unit fails which is used to operate a fused disconnect device. This design typically results in a simpler bank configuration and provides an easy method for field identification of a failed unit. A fused design also requires less sensitive unbalance protection since the fuse is the principal method used for isolating a can failure. However, this style of bank has a higher initial cost and usually higher maintenance costs. Since the fused element is exposed to the environment, the fuses become less reliable

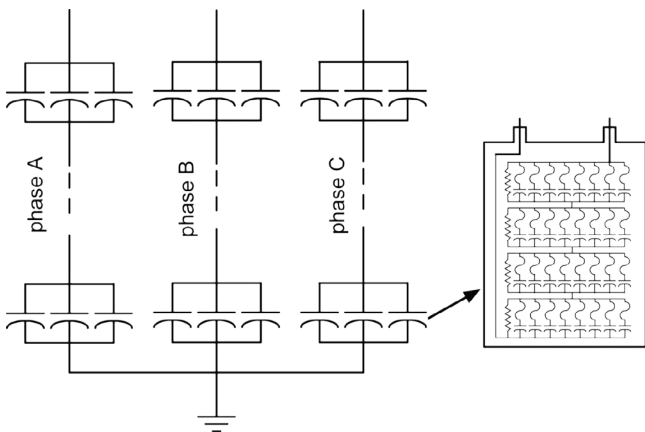

**Figure 3.**  
*Internally fused shunt capacitor bank and capacitor unit.*

and require more maintenance to ensure correct operation. As a result, fuseless capacitor banks have become increasingly popular. Elimination of the fused connection results in a lower initial cost, reduced maintenance costs, smaller bank footprint, and fewer losses. Also, this bank design typically makes catastrophic can rupture less likely since the discharge energy of a failed element will be small.

However, the fuseless bank design has two main disadvantages that increase the emphasis on requiring sensitive relaying protection. One, the elimination of the external fuse means that visual indication of the failed capacitor has been lost. In addition, an element failure results in an overvoltage condition of the remaining elements, stressing them. Without a fuse as a means of isolating the failed can, the protective relay must now be sensitive enough to detect a failed element and alarm before additional elements fail causing a higher overvoltage condition on the remaining units. Because of these two factors, it is especially important to utilize a sensitive protective relay which can correctly isolate a bank for a failed element. Also, the use of faulted phase identification assists field personnel in locating a failed capacitor can without having to test the entire bank.

The optimum connection for a SCB depends on the best utilization of the available voltage ratings of capacitor units, fusing, and protective relaying. Virtually all HV and EHV banks are connected in one of the two wye configurations listed below [1,2]. Distribution capacitor banks, however, may be connected in wye or delta. Some banks may use an H configuration on each of the phases with a current transformer in the connecting branch to detect the unbalance.

### 3.1 Grounded Wye-Connected Banks

Grounded wye capacitor banks are composed of series and parallel-connected capacitor units per phase and provide a low impedance path to ground. This offers some protection from surge overvoltages and transient overcurrent conditions.

When a capacitor bank becomes too large, making the parallel energy of a series group too high for the capacitor units or fuses (above 4650kVAR), the bank may be split into two wye sections. The characteristics of the grounded double wye are similar to a grounded single wye bank. The two neutrals should be directly connected with a single path to ground.

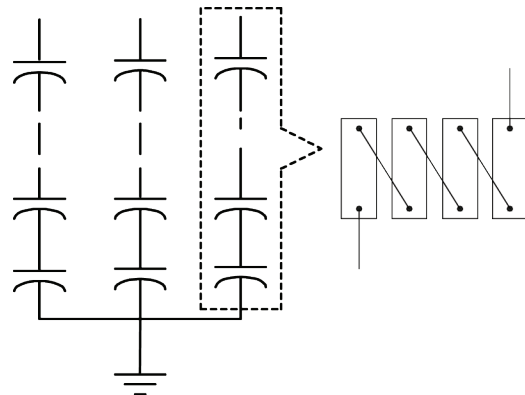

**Figure 4.**  
*Fuseless shunt capacitor bank and series string.*

The double wye design facilitates better protection methods. Even with inherent unbalances the two banks will respond similarly to system events, and therefore, methods based on comparing one split-phase versus the other are more sensitive and less prone to system events (phase current balance technique, for example).

### 3.2 Ungrounded Wye-Connected Banks

Ungrounded wye banks do not permit zero sequence currents, third harmonic currents, or large capacitor discharge currents during system ground faults (phase-to-phase faults may still occur and will result in large discharge currents). Another advantage is that overvoltages appearing at the CT secondaries are not as high as in the case of grounded banks. However, the neutral should be insulated for full line voltage because it is momentarily at phase potential when the bank is switched or when one capacitor unit fails in a bank configured with a single group of units.

### 3.3 Delta-Connected Banks

Delta-connected banks are generally used only at distribution voltages and are configured with a single series group of capacitors rated at line-to-line voltage. With only one series group of units no overvoltage occurs across the remaining capacitor units from the isolation of a faulted capacitor unit.

### 3.4 H-Configuration

Some larger banks use an H configuration in each phase with a current transformer connected between the two legs to compare the current down each leg. As long as all capacitors are balanced, no current will flow through the current transformer. If a capacitor fuse operates, some current will flow through the current transformer. This bridge connection facilitates very sensitive protection. The H arrangement is used on large banks with many capacitor units in parallel.

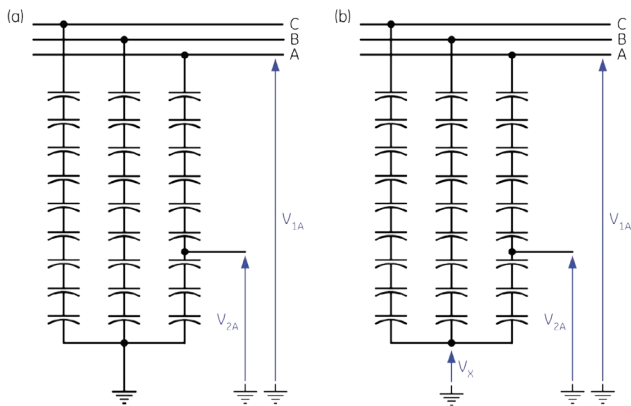

**Figure 5.**  
Voltage differential application to grounded (a) and ungrounded (b) banks.

## 4. Sensitive Capacitor Bank Protection Methods

### 4.1 Voltage Differential (87V)

With reference to Figure 5, this function is based on a voltage divider principle – a healthy capacitor string has a constant and known division ratio between its full tap (typically the bus voltage) and an auxiliary tap used by the protection. The principle could be used on both grounded (Figure 5a) and ungrounded (Figure 5b) banks. In the latter case the neutral point voltage ( $V_x$ ) must be measured by the relay, and used to derive the voltage across the string.

The function uses the following operating signal:

$$V_{OP(A)} = |V_{1A} - k_A \cdot V_{2A}| \quad \text{for grounded banks} \quad (1a)$$

$$V_{OP(A)} = |V_{1A} - k_A \cdot V_{2A} + V_x \cdot (k_A - 1)| \quad \text{for ungrounded banks} \quad (1b)$$

Where  $k_A$  is a division ratio for the A-phase of the bank.

Identical relations apply to phases B and C.

Note that equations (1) can be implemented using either phasors or magnitudes. During no-fault conditions and under small bank unbalances caused by internal bank failures, the two voltages will be almost in phase, suggesting the phasors and magnitude versions would yield similar results. However, the function is set very sensitive and given possible angular errors of the used VTs, there will be differences in performance between the two possible versions. The performance depends on the type of security measures used to deal with errors of instrument transformers. More information is provided in one of the following sections.

Typically, the method is used on grounded banks and equation (1a) is used. In theory, the algorithm could be applied on ungrounded banks using equation (1b), but it requires both the neutral voltage and the tap voltages to be measured. Such arrangements may not be practical (the tap voltages not measured on ungrounded banks). If the tap voltages are measured, one could apply multiple overlapping protection zones to the ungrounded bank as long as the applied relay(s) support the required number of inputs and associated protection functions. Specifically, equation (1b) can be used for voltage differential; and two neutral voltage unbalance protection elements can be used – one balancing the bus voltages with the neutral voltage, and another balancing the tap voltages against the neutral voltage.

Equations (1) apply to primary voltages, and as such they incorporate the voltage-dividing ratio of the capacitor, but ignore the ratios of applied instrument transformers. In secondary voltages, the operating voltage is:

$$V_{OP(A)} = |V_{1A} - k_A \cdot V_{2A}| \quad \text{for grounded banks} \quad (1c)$$

$$V_{OP(A)} = |V_{1A} - k_A \cdot V_{2A} + V_x \cdot (k_A - 1)| \quad \text{for ungrounded banks} \quad (1d)$$

Where the operating signal is in secondary volts of the bus VT, and the  $n_{VT}$ ,  $n_{VT2}$  and  $n_{VTX}$  stand for ratios of the bus, tap, and neutral voltage transformers, respectively.

Normally the VT ratios are selected so that the secondary voltages for the bus and tap voltages are similar under nominal system voltage. This leads to the effective matching factor for the secondary voltages being close to unity:

$$k_A \cdot \frac{n_{VT2}}{n_{VT1}} \approx 1 \quad (1e)$$

Voltage-based capacitor protection functions are set sensitive. Given the format of equations (1) both the bus and tap voltages shall be measured accurately in order to gain sensitivity of protection. As a result the VT ratios shall be selected so that the resultant secondary voltages fall in the region of maximum relay accuracy, and the two VTs work within their maximum class accuracy under nominal system voltage. The latter is ensured for the bus voltage; selection of the VT for the tap voltage shall be done carefully to minimize VT and relay errors for the tap voltage. Relay setting range for the ratio-matching factor is another condition that may limit selection of this VT ratio.

The following characteristics apply to the voltage differential function [3]:

- The element shall support individual per-phase settings to cope with different unbalances between the phases (repairs and shorted units).
- The element is capable of indicating the affected phase, and potentially the number of faulted capacitor elements, to aid troubleshooting and repairs of the bank.
- The function shall apply appropriate security measures for sensitive but secure operation: appropriate restraint signal could be developed to accompany the operating signal (1). Setting range shall allow disabling the restraint if desired so.
- Several independent pickup thresholds shall be provided for alarming and tripping.
- The voltage matching coefficients ( $k$ ) shall be individually settable per phase.
- Both auto-setting and self-tuning applications of this method are possible. Provision could be made to calculate the matching factors  $k$  automatically under manual supervision of the user, either locally or remotely (auto-setting), or calculate the factor constantly in a slow adjusting loop (self-tuning).

The process of finding the constant balancing a given phase of protection is based on the following simple equation:

$$\hat{k}_A = \frac{V_{1A}}{V_{2A}} \quad (\text{under no-fault conditions}) \quad (2)$$

The voltage differential method can be used in a number of configurations as long as the relay allows wide range of ratio matching for the compared voltages: tap voltage can be compared with the bus voltage; two taps can be compared on the same bank; two taps can be compared between two parallel banks, etc.

## 4.2 Compensated Bank Neutral Voltage Unbalance (59NU)

With reference to Figure 6 this function is applicable to ungrounded banks, and is based on the Kirchhoff's currents law for the neutral node of the bank:

$$\frac{V_A - V_X}{Z_A} + \frac{V_B - V_X}{Z_B} + \frac{V_C - V_X}{Z_C} = 0 \quad (3a)$$

The above expression can be rearranged as follows:

$$-V_X \cdot \left( \frac{1}{Z_A} + \frac{1}{Z_B} + \frac{1}{Z_C} \right) + \frac{V_A}{Z_A} + \frac{V_B}{Z_B} + \frac{V_C}{Z_C} = 0 \quad (3b)$$

and further to an equivalent form of:

$$-V_X \cdot \left( \frac{1}{Z_A} + \frac{1}{Z_B} + \frac{1}{Z_C} \right) + \frac{V_A}{Z_A} + \frac{V_B}{Z_A} + \frac{V_C}{Z_A} + \frac{V_B}{Z_B} - \frac{V_B}{Z_A} + \frac{V_C}{Z_C} - \frac{V_C}{Z_A} = 0 \quad (3c)$$

which is identical with:

$$-V_X \cdot \left( \frac{1}{Z_A} + \frac{1}{Z_B} + \frac{1}{Z_C} \right) + \frac{1}{Z_A} \cdot (V_A + V_B + V_C) + V_B \cdot \left( \frac{1}{Z_B} - \frac{1}{Z_A} \right) + V_C \cdot \left( \frac{1}{Z_C} - \frac{1}{Z_A} \right) = 0 \quad (3d)$$

Multiplying both sides by  $3 \cdot V_0$  and substituting the sum of the phase voltages by  $3 \cdot V_0$

yields:

$$V_X \cdot \left( 1 + \frac{Z_A}{Z_B} + \frac{Z_A}{Z_C} \right) - 3 \cdot V_0 + V_B \cdot \left( 1 - \frac{Z_A}{Z_B} \right) + V_C \cdot \left( 1 - \frac{Z_A}{Z_C} \right) = 0 \quad (3e)$$

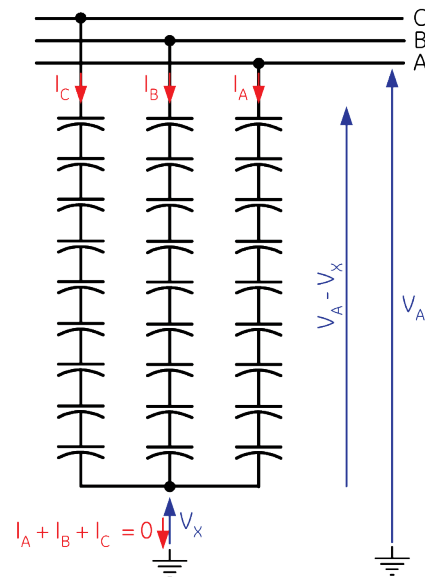

Figure 6. Compensated bank neutral overvoltage application.



Introducing the following matching  $k$ -values to reflect the inherent bank unbalance:

$$k_{AB} = \frac{Z_A}{Z_B} \approx \frac{X_A}{X_B}, \quad k_{AC} = \frac{Z_A}{Z_C} \approx \frac{X_A}{X_C} \quad (4)$$

allows re-writing the balance equation (3e) into the following operating signal:

$$V_{OP} = \frac{1}{3} \left| (1 + k_{AB} + k_{AC}) \cdot V_x - 3 \cdot V_0 + V_B \cdot (1 - k_{AB}) + V_C \cdot (1 - k_{AC}) \right| \quad (5)$$

Equation (5) involves phasors, not magnitudes, i.e. the vectorial sum of the voltages is created by the protection function implementing the method.

Note that the ratios of the capacitor impedances between phase A and the two other phases are close to unity, and therefore the correcting factors for the B and C-phase voltages are small numbers, while the coefficient in front of the  $V_x$  voltage is close to 3.

Equation (5) while following relations (4) is a proper neutral overvoltage function compensated for both the system unbalance ( $V_0$ ), and the bank unbalance ( $k_{AB}$ ,  $k_{AC}$ ). To understand it better assume the bank is perfectly balanced ( $k_{AB} = 1$ ,  $k_{AC} = 1$ ). If so, the precise operating equation takes a familiar simplified form [1]:

$$V_{OP} = \left| V_x - V_0 \right| \quad (6)$$

Equation (5) identifies the source of the inherent bank unbalance, and therefore allows for proper compensation. In addition, this key equation allows analyzing the impact of imperfect compensation and/or errors of instrument transformers on sensitivity of protection as explained later in this paper.

Equation (5) can be implemented using either derived neutral component in the bus voltages (vectorial sum of the phase voltages calculated by the relay), or directly measured neutral voltage component (open-delta VT voltage). Slightly different errors would occur in these two approaches.

When deriving the  $3 \cdot V_0$  internally the relay is presented with near-nominal voltages under internal failures that require high protection sensitivity, typically has maximum accuracy of voltage measurement under such conditions, and calculates the vectorial voltage sum with relatively high accuracy.

When measuring the  $3 \cdot V_0$  directly the relay is presented with a very small signal under internal failures that require high protection sensitivity. In order to keep high accuracy a high-sensitivity voltage relay input shall be used. At the same time, this voltage could reach as high as system nominal voltage during external faults. Therefore, the input range shall be high enough to measure this voltage correctly and balance it accurately against the  $V_x$  signal.

The  $V_x$  voltage, in turn, is relatively small under internal failures that require high protection sensitivity. Therefore either the relay shall be equipped with a high-sensitivity voltage input, or the VT ratio is selected to create this signal and improve measuring accuracy of this signal, or both. In any case, the ratio must be selected such as the input voltage does not exceed the conversion range of a given relay. Sometimes this requirement may be relaxed allowing

saturation of the relay input – the function shall be blocked in this case under external faults either by time delay or explicit logic in order to cope with the spurious unbalance caused by saturation of the  $V_x$  measurement. In any case, one shall observe the thermal withstand rating of the relay input when selecting relatively low-ratio VT for the measurement of the  $V_x$  signal.

When written for secondary voltages the key operating equation becomes:

- When measuring the  $3 \cdot V_0$  internally and expressing the operating signal in secondary volts of the bus voltage:

$$V_{OP} = \frac{1}{3} \left| \frac{n_{VTX}}{n_{VT}} (1 + k_{AB} + k_{AC}) \cdot V_x - 3 \cdot V_0 + V_B \cdot (1 - k_{AB}) + V_C \cdot (1 - k_{AC}) \right| \quad (7a)$$

- When measuring the  $3 \cdot V_0$  from an open-delta VT and expressing the operating signal in secondary volts of the bus voltage:

$$V_{OP} = \frac{1}{3} \left| \frac{n_{VTX}}{n_{VT}} (1 + k_{AB} + k_{AC}) \cdot V_x - 3 \cdot \frac{n_{VT0}}{n_{VT}} V_0 + V_B \cdot (1 - k_{AB}) + V_C \cdot (1 - k_{AC}) \right| \quad (7b)$$

The following characteristics apply to the compensated bank neutral voltage unbalance function [3]:

- The single element function does not indicate explicitly the effected phase. It could, however, aid troubleshooting and repairs by reporting the  $k$ -factors (pre-fault and fault values).
- The function shall apply appropriate security measures for sensitive but secure operation: appropriate restraint signal could be used with the operating signal (5). Disabling the restraint should be allowed if desired so.
- Several independent pickup thresholds shall be provided for alarming and tripping.
- The inherent bank unbalance constants ( $k$ -values) shall be settable.
- Both auto-setting and self-tuning applications are possible as long as the neutral point voltage is non-zero and is measured with adequate accuracy. Provision could be made to calculate factors  $k$  automatically under manual supervision of the user, either locally or remotely (auto-setting), or continuously in a slow adjusting loop (self-tuning).

$$\text{Re} \left\{ (1 + k_{AB} + k_{AC}) \cdot V_x - 3 \cdot V_0 + V_B \cdot (1 - k_{AB}) + V_C \cdot (1 - k_{AC}) \right\} = 0 \quad (8a)$$

$$\text{Im} \left\{ (1 + k_{AB} + k_{AC}) \cdot V_x - 3 \cdot V_0 + V_B \cdot (1 - k_{AB}) + V_C \cdot (1 - k_{AC}) \right\} = 0 \quad (8b)$$

The process of finding the two unknown constants is based on the following principle. When the bank is healthy, equation (5) is perfectly balanced, and therefore it can be zeroed out. Writing the real and imaginary parts of the equation separately one obtains two equations for two unknowns.

The above is now solved for the two unknowns  $k_{AB}$  and  $k_{AC}$  while treating the involved voltages as knowns (the  $k$ -values are treated as real numbers per equations (4)). The method works as long as the  $V_x$  voltage is above the measuring error level. The procedure does not call for the system to be unbalanced ( $V_0$  can be zero) as the unknowns ( $k$ ) do not appear as multipliers for the  $V_0$  value in equations (8).

### 4.3. Phase Current Balance (60P)

With reference to Figure 7, this function is based on the balance between phase currents of the two parallel banks, and is applicable to both grounded and ungrounded arrangements. Higher sensitivity can be achieved when using a window CT (compared with the two individual CTs summated electrically). With the two banks slightly different, a circulating current flows, and shall be compensated for in order to increase sensitivity of the function. This protection element is founded on the following theory.

Both parallel banks work under identical voltage, and therefore:

$$I_{DIF(A)} = V_{BANK(A)} \frac{Z_{1A} - Z_{2A}}{Z_{1A} \cdot Z_{2A}} \quad (9a)$$

$$I_A = V_{BANK(A)} \frac{Z_{1A} + Z_{2A}}{Z_{1A} \cdot Z_{2A}} \quad (9b)$$

Utilizing the fact the voltage is the same in expressions (9a) and (9b) one writes:

$$V_{BANK(A)} = I_{DIF(A)} \cdot \frac{Z_{1A} \cdot Z_{2A}}{Z_{1A} - Z_{2A}} = I_A \cdot \frac{Z_{1A} \cdot Z_{2A}}{Z_{1A} + Z_{2A}} \quad (9c)$$

creating the following balance equation:

$$I_{DIF(A)} \frac{Z_{1A} \cdot Z_{2A}}{Z_{1A} - Z_{2A}} - I_A \frac{Z_{1A} \cdot Z_{2A}}{Z_{1A} + Z_{2A}} = 0 \quad (9d)$$

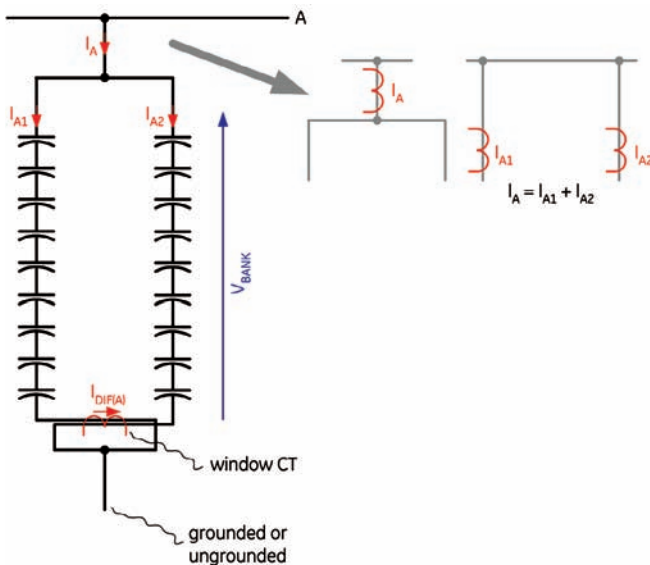

Figure 7. Phase current balance application.

Dividing both sides by the coefficient next to the differential current gives:

$$I_{DIF(A)} - I_A \frac{Z_{1A} - Z_{2A}}{Z_{1A} + Z_{2A}} = 0 \quad (9e)$$

Introducing the inherent unbalance compensating factor,  $k$ :

$$k_A = \frac{Z_{1A} - Z_{2A}}{Z_{1A} + Z_{2A}} \approx \frac{X_{1A} - X_{2A}}{X_{1A} + X_{2A}} \quad (10)$$

yields the following operating signal of the phase current balance protection:

$$I_{OP(A)} = \left| I_{DIF(A)} - k_A \cdot I_A \right| \quad (11)$$

Identical relations apply to phases B and C.

The operating signal (11) implements proper compensation for the inherent unbalance of the bank. The equation identifies that the error is proportional to the amount of the total phase current ( $I_A$ ) and the difference between the impedances of the two banks ( $k_A$ ). When not compensated, the straight differential current would display a non-zero value "leaking" from the phase current. Subtracting the historical value of such leakage current, often applied today, improves sensitivity but it is not a correct way of compensating this functions. More discussion follows in section 5 of this paper.

Note that equation (11) is a vectorial difference between the two signals. However, as the  $k$ -factor is a real number (very small or zero imaginary part), the two currents are in phase and their magnitudes, not phasors, could be used as well.

Typically CTs used to measure the total phase current and the differential current would have drastically different ratios. The differential CT might have much lower ratio in order to increase magnitude of the secondary current under internal bank failures requiring high sensitivity of protection. During external fault conditions, the differential current remains low further promoting the usage of low-ratio CT. On the relay side, a sensitive ground current input shall be used for better sensitivity and accuracy.

When written in secondary terms, the key equation (11) when expressed in secondary amperes of the differential CT becomes:

$$I_{OP(A)} = \left| I_{DIF(A)} - k_A \cdot \frac{n_{CT}}{n_{CT DIF}} \cdot I_A \right| \quad (12)$$

The following characteristics apply to the phase current balance function [3]:

- The element shall support individual per-phase settings.
- The function indicates the effected phase, as well as reports the change in the current division ratio,  $k$  (pre-fault and fault values) to aid troubleshooting and repairs of the bank.
- The element shall apply appropriate security measures for sensitive but secure operation: appropriate restraint signal could be provided to accompany the operating signal (11). Disabling the restraint shall be possible if desired so.

- Several independent thresholds shall be provided per phase for alarming and tripping.
- The current dividers ( $k$ ) are individually set per phase.
- Both auto-setting and self-tuning applications of this method are possible. Provision could be made to calculate factors  $k$  automatically under manual supervision of the user, either locally or remotely (auto-setting), or constantly in a slow adjusting loop (self-setting).

The process of finding the balancing constants for each phase of protection is based on the following simple equation:

$$\hat{k}_A = \frac{I_{DIF(A)}}{I_A} \quad (\text{under no-fault conditions}) \quad (13)$$

#### 4.4 Neutral Current Balance (60N)

With reference to Figure 8, this function is based on the balance between interconnected neutral currents of two parallel banks, and is applicable to both grounded and ungrounded installations. A window CT measuring the vectorial difference between the two neutral currents allows for better accuracy/sensitivity.

With the two banks possibly slightly different, a circulating zero-sequence current may be present and shall be compensated for in order to increase sensitivity of the function.

Proper inherent unbalance compensation is founded on the following theory.

Both parallel banks work under identical voltages, therefore their phase currents are driven by the individual admittances in each phase of each bank:

$$I_{A1} = (V_A - V_X) \cdot Y_{A1}; \quad I_{A2} = (V_A - V_X) \cdot Y_{A2} \quad (14a)$$

$$I_{B1} = (V_B - V_X) \cdot Y_{B1}; \quad I_{B2} = (V_B - V_X) \cdot Y_{B2} \quad (14b)$$

$$I_{C1} = (V_C - V_X) \cdot Y_{C1}; \quad I_{C2} = (V_C - V_X) \cdot Y_{C2} \quad (14c)$$

The sum of the two neutral currents can be derived from the above equations:

$$I_{N1} = I_{A1} + I_{B1} + I_{C1} = (V_A - V_X) \cdot Y_{A1} + (V_B - V_X) \cdot Y_{B1} + (V_C - V_X) \cdot Y_{C1} \quad (14d)$$

$$I_{N2} = I_{A2} + I_{B2} + I_{C2} = (V_A - V_X) \cdot Y_{A2} + (V_B - V_X) \cdot Y_{B2} + (V_C - V_X) \cdot Y_{C2} \quad (14e)$$

The differential current is a vectorial difference between the two currents. By subtracting (14e) from (14d) one obtains:

$$I_{DIF} = I_{N1} - I_{N2} = (V_A - V_X) \cdot (Y_{A1} - Y_{A2}) + (V_B - V_X) \cdot (Y_{B1} - Y_{B2}) + (V_C - V_X) \cdot (Y_{C1} - Y_{C2}) \quad (14f)$$

At the same time the total currents in each phase are driven by the total admittance of the two banks in each phase:

$$I_A = I_{A1} + I_{A2} = (V_A - V_X) \cdot (Y_{A1} + Y_{A2}) \quad (15a)$$

$$I_B = I_{B1} + I_{B2} = (V_B - V_X) \cdot (Y_{B1} + Y_{B2}) \quad (15b)$$

$$I_C = I_{C1} + I_{C2} = (V_C - V_X) \cdot (Y_{C1} + Y_{C2}) \quad (15c)$$

Inserting equations (15) into equations (14) allows eliminating the voltages and derive the all-current balance equation for the two banks:

$$I_{DIF} = I_A \cdot \frac{Y_{A1} - Y_{A2}}{Y_{A1} + Y_{A2}} + I_B \cdot \frac{Y_{B1} - Y_{B2}}{Y_{B1} + Y_{B2}} + I_C \cdot \frac{Y_{C1} - Y_{C2}}{Y_{C1} + Y_{C2}} \quad (16)$$

Labeling:

$$k_A = \frac{Y_{A1} - Y_{A2}}{Y_{A1} + Y_{A2}}; \quad k_B = \frac{Y_{B1} - Y_{B2}}{Y_{B1} + Y_{B2}}; \quad k_C = \frac{Y_{C1} - Y_{C2}}{Y_{C1} + Y_{C2}} \quad (17)$$

One gets the following operating equation balancing the protected bank:

$$I_{OP} = |I_{DIF} - (k_A \cdot I_A + k_B \cdot I_B + k_C \cdot I_C)| \quad (18)$$

When the banks are identical, i.e. phases A are equal, phases B are equal and phases C are equal, the operating equation (18) simplifies to a straight overcurrent condition for the measured neutral differential current.

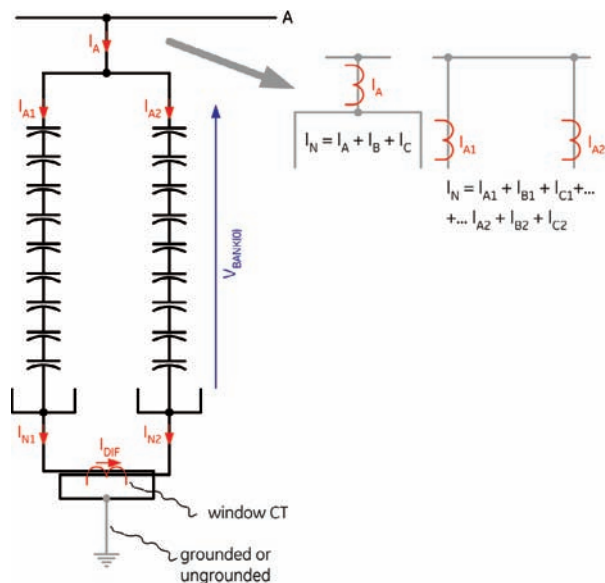

Figure 8. Neutral current balance application.



It is justified to assume the balancing constants,  $k$ , are real numbers. Still, this leaves the balance equation (18) with 3 unknowns. These unknowns can be calculated based on several measurements taken under unbalanced conditions.

Alternatively, equation (18) may be re-written from phase coordinates, into sequence components:

$$I_{OP} = \left| I_{DIF} - (k_0 \cdot I_0 + k_1 \cdot I_1 + k_2 \cdot I_2) \right| \quad (19)$$

It is justified to assume that the positive-sequence current would leak into the operating quantity more considerably compared with the zero and negative-sequence components. Therefore only the positive-sequence leakage can be eliminated to improve sensitivity. This approach yields a slightly simplified form of the mathematically accurate equations (18) and (19):

$$I_{OP} = \left| I_{DIF} - k_1 \cdot I_1 \right| \quad (20)$$

With one unknown balancing factor ( $k_1$ ) the auto-setting or self-tuning procedures can be implemented simply as:

$$I_{OP} = \left| I_{DIF} - k_1 \cdot I_1 \right| \quad (\text{under no-fault conditions}) \quad (21)$$

Unlike in previous methods, this compensating coefficient may be a complex number.

Operating signal (18) or (19) implements proper compensation for the inherent unbalance of the bank. Equation (20) is a good practical approximation.

Equation (18) holds for primary currents, when applied to secondary amperes, it takes the following form:

$$I_{OP} = \left| I_{DIF} - \frac{n_{CT}}{n_{CT DIF}} \cdot (k_A \cdot I_A + k_B \cdot I_B + k_C \cdot I_C) \right| \quad (22)$$

Typically the differential CT would be of lower ratio in order to increase the level of the secondary current for internal failures that call for increased sensitivity of protection. During external faults, the differential current will be increased but not dramatically.

The following characteristics apply to the neutral current balance function [3]:

- The single element function does not indicate explicitly the effected phase.
- The function shall apply appropriate security measures for sensitive but secure operation (provision for a restraint signal).
- Several independent thresholds shall be provided that can be freely used for alarming and tripping.
- The positive-sequence compensating factor  $k_1$  shall be a setting.
- Provision could be made to calculate the  $k$ -factor automatically under manual supervision of the user, either locally or remotely (auto-setting), or continuously in a slow adjusting loop (self-tuning).

## 5. Sensitivity to Internal Bank Failures

The key equations defining the outlined capacitor bank protection methods ((1), (5), (11) and (18)) allow not only proper compensation for the inherent bank unbalance, but also facilitate analysis of sensitivity of protection.

Each of the four methods as described in this paper is founded on a balance equation that assumes:

First, that the bank is intact in terms of experiencing a ground or phase fault.

Second, that the inherent unbalance between the capacitor phases does not change.

A ground or phase fault violating the first assumption results in severe unbalance in the operating equations, and leads to protection operation as expected. This aspect of operation is backed-up by overcurrent protection, and therefore is of secondary importance.

A short or open in a single or several cans violates the second assumption, causes a minor unbalance in the operating equations, and results in operation of protection set sensitive enough given the size of the internal failure.

This latter way of responding to internal failures is critical for analysis of protection sensitivity. For this purpose one could assume nominal system voltages and resulting currents, and use the operating equations to determine the amount of the operating signals in response to any given unbalance in the bank.

### 5.1 Sensitivity of the Voltage Differential Function

For simplicity let us focus on the application to grounded banks. Neglecting the phase index, the operating signal in this method is (equation (1a)):

$$V_{OP} = \left| V_1 - k_{SET} \cdot V_2 \right|$$

The actual voltage-dividing ratio during internal failures of the bank is:

$$k_{FAIL} = \frac{Z_{BUS-TAP} + Z_{TAP-GND}}{Z_{TAP-GND}} = 1 + \frac{Z_{BUS-TAP}}{Z_{TAP-GND}} = 1 + \frac{C_{TAP-GND}}{C_{BUS-TAP}} \quad (23a)$$

The tap voltage during the failure is:

$$V_2 = V_1 \cdot \frac{1}{k_{FAIL}} \quad (23b)$$

and the operating signal becomes:

$$V_{OP} = \left| V_1 \cdot \left| 1 - \frac{k_{SET}}{k_{FAIL}} \right| \right| \quad (23c)$$

As a percentage of the full bus voltage the operating signal is:

$$\frac{V_{OP}}{|V_1|} = \left| 1 - \frac{k_{SET}}{k_{FAIL}} \right| \cdot 100\% \quad (24d)$$

Equation (24d) yields a proportional relationship between  $k_{FAIL}$  and the operating voltage: a change by 1% in the  $k$ -value, yields an extra 1% of nominal in the operating signal.

What is more interesting, however, is the relation between changes in the bus-tap and tap-ground capacitances and the increase in the operating voltage. Given equation (23a) one can write:

$$\Delta V_{OP\%} = \Delta k_{FAIL\%} = \Delta C_{BUS-TAP\%} = \Delta C_{TAP-GND\%} \quad (25)$$

The above signifies that a 1% change in either of the bus-to-tap or tap-to-ground capacitances would yield 1% of bus nominal in the operating voltage.

Depending on the serial/parallel arrangement of the cans, it will take a certain amount of shorted/opened cans to cause a single percentage change in the capacitance and an equivalent increase in the operating voltage. The final assessment of sensitivity has to take into account the actual arrangement of the capacitor bank.

An interesting question is the optimum location of the tap. Regardless of the number of parallel cans, the longer the string, the higher the impedance. If so a single can failure would cause a smaller percentage change in the overall impedance/capacitance. For best sensitivity both the portions (bus-tap and tap-ground) shall be kept as short as possible as measured in the number of cans. In reality, the number of cans is not a variable. Within this restriction, half of the total length is the smallest possible length.

Therefore the exact middle position of the tap is optimum from the point of view of sensitivity. Under the mid-tap both the portions (bus-tap and tap-ground) are protected with the same sensitivity measured in the number of cans.

Often, the tap is installed below the mid-point in order to apply lower voltage VTs. This creates a classical trade-off between optimum performance and low cost of installation.

## 5.2 Sensitivity of the Compensated Bank Neutral Voltage Unbalance Function

The analysis shall start with the full operating equation (5):

$$V_{OP} = \frac{1}{3} \left| (1 + k_{AB} + k_{AC}) \cdot V_x - 3 \cdot V_0 + V_B \cdot (1 - k_{AB}) + V_C \cdot (1 - k_{AC}) \right|$$

in which the following assumptions can be made:

- The  $1-k$  terms can be neglected for simplicity.
- The system zero-sequence voltage can be considered zero (the system is practically always strong enough to maintain the balance at the bus despite few cans affected within the bank itself).

This leads to the following relationship:

$$V_{OP} = \frac{1}{3} \left| (1 + k_{AB} + k_{AC}) \cdot V_x \right| \quad (26a)$$

As both the  $k$ -values are close to unity, the above simplifies to:

$$V_{OP} \approx |V_x| \quad (26b)$$

Equation (3e) helps calculating the amount of the neutral point voltage. Assuming system zero-sequence voltage nil, the equation can be re-arranged to calculate the value of  $V_x$ :

$$|V_x| = \left| \frac{V_B(1 - k_{AB}) + V_C(1 - k_{AC})}{1 + k_{AB} + k_{AC}} \right| \quad (27a)$$

Assuming a balanced bus voltage:

$$V_B = a^2 \cdot V_A, \quad V_C = a \cdot V_A, \quad a = 1 \angle 120^\circ \quad (27b)$$

One simplifies further:

$$|V_x| = |V_A| \cdot \left| \frac{a^2 \cdot (1 - k_{AB}) + a \cdot (1 - k_{AC})}{1 + k_{AB} + k_{AC}} \right| \quad (27c)$$

Observing the  $k$ -values are real numbers close to unity and using properties of the  $a$ -operand yields the following:

$$\frac{|V_x|}{|V_A|} = \left| \frac{1 - \frac{1}{2}(k_{AB} + k_{AC}) + j \frac{\sqrt{3}}{2}(k_{AC} - k_{AB})}{1 + k_{AB} + k_{AC}} \right| \quad (27d)$$

Because the actual operating equation (5) compensates for the inherent bank unbalance, it is further justified to assume the ratios of the impedances to be a perfect unity (say  $k_{AB}$ ), and treat the other ratio as a variable ( $k_{AC}$  correspondingly):

$$\frac{|V_x|}{|V_A|} = \left| \frac{1 - j \frac{\sqrt{3}}{2} - \frac{1}{2}k + j \frac{\sqrt{3}}{2}k}{2 + k} \right| = \left| \frac{k - 1}{2 + k} \right| \quad (27e)$$

The above equations means that only 1/3rd of the percentage change in the ratio of impedances between any two phases will be seen as a percentage of nominal bus voltage:

$$\Delta V_{OP\%} = \frac{1}{3} \Delta k_{\%} = \frac{1}{3} \Delta C_{\%} \quad (28)$$

For example it will take 3% in the drop of the phase A impedance, to see 1% of bus nominal voltage as the  $V_x$  signal, and thus the operating signal of the function.

The operating signal has an arbitrary factor 1/3rd to comply with the common understanding of this method (equation (6)). Using microprocessor-based relay technology this scaling is not important as any scaling can be handled accurately. What is important is the 1:3 ratio between the measured neutral point voltage and changes in the capacitor impedance.

This reinforces using low-ratio VTs for measuring the neutral-point voltage.

Relation (28) can also be used to calculate the required ratio. For example, assuming target sensitivity for the function, one calculates the effective operating signal as percentage of the bus voltage. Using relay accuracy claim, one determines the minimum secondary voltage that is required for the proper operation of the relay. Combining the two requirements allows calculating the ratio for the VT:

$$n_{VTX} = \frac{\Delta C_{\%} \cdot V_{BUS}}{3 \cdot \sqrt{3} \cdot V_{SEC(MIN)}} \quad (29)$$

For example, with the target sensitivity of 1% of impedance change on a 345kV bus, and the minimum relay voltage of 0.5V secondary, the maximum VT ratio is:

$$n_{VTX} = \frac{0.01 \cdot 345kV}{3 \cdot \sqrt{3} \cdot 0.5V} = 1328$$

With this ratio, under SLG fault on the bus, the secondary voltage would be 150V. This is well within the range of modern relays. Assuming a relay conversion range of 260VRMS, the ratio can be lowered to  $1328 \cdot 150 / 260 = 766$ , yielding the operating signal of 0.87V secondary at 1% change in the capacitor impedance.

### 5.3 Sensitivity of the phase current balance function

Neglecting the phase index, the operating signal of this method is (equation (11)):

$$I_{OP} = |I_{DIF} - k_{SET} \cdot I|$$

It is justified to assume the total capacitor current does not change in response to the internal failure of limited size, therefore the operating current as a percentage of the total capacitor current equals the percentage change in the  $k$ -value:

$$\frac{\Delta I_{OP}}{I} = \frac{1}{100} \Delta k_{\%} \quad (30a)$$

For example, 1% of change in the  $k$ -factor yields 1% of the full current as measured by the split-phase CT.

Next step is to understand the impact of impedance/capacitance changes on the changes in the  $k$ -factor. From equation (10):

$$k = \frac{X_1 - X_2}{X_1 + X_2}$$

Observing that the two reactances are very similar, one obtains:

$$\Delta k_{\%} = \frac{1}{2} \Delta X_{\%} = \frac{1}{2} \Delta C_{\%} \quad (30b)$$

Equations (30) mean that for each % of change in the impedance/capacitance of one of the parallel banks, there will be increase in the differential current by 0.5% of the total bank current.

Again, the above observation may be used to select the ratio of the split-phase CT: the target accuracy allows calculating the minimum primary operating signal; the minimum relay sensitivity allows determining the minimum accurately measured secondary signal; the ratio dictates the maximum CT ratio that can be applied in this case:

$$n_{DIF} = \frac{\Delta C_{\%} \cdot I_{NOM}}{2 \cdot I_{SEC(MIN)}} \quad (31)$$

### 5.4 Sensitivity of the Neutral Current Balance

It is worth noticing that this method is a derivative of the phase current balance approach (60P), and as such it has identical sensitivity.

The balance equations for all three phases per the 60P protection principle are:

$$I_{DIF(A)} - I_A \frac{Z_{1A} - Z_{2A}}{Z_{1A} + Z_{2A}} = 0 \quad (32a)$$

$$I_{DIF(B)} - I_B \frac{Z_{1B} - Z_{2B}}{Z_{1B} + Z_{2B}} = 0 \quad (32b)$$

$$I_{DIF(C)} - I_C \frac{Z_{1C} - Z_{2C}}{Z_{1C} + Z_{2C}} = 0 \quad (32c)$$

Observing that in the 60P method:

$$I_{DIF(A)} = I_{A1} - I_{A2}, \quad I_{DIF(B)} = I_{B1} - I_{B2}, \quad I_{DIF(C)} = I_{C1} - I_{C2} \quad (33a)$$

While in the 60N method:

$$\begin{aligned} I_{DIF} &= I_{N1} - I_{N2} = (I_{A1} + I_{B1} + I_{C1}) - (I_{A2} + I_{B2} + I_{C2}) = \dots \\ &\dots = (I_{A1} - I_{A2}) + (I_{B1} - I_{B2}) + (I_{C1} - I_{C2}) \end{aligned} \quad (33b)$$

allows one to insert (33a) into (33b) and obtain:

$$I_{DIF} = I_{DIF(A)} + I_{DIF(B)} + I_{DIF(C)} \quad (33c)$$

Now inserting (32a-c) into (33c) yields:

$$I_{DIF} = I_A \frac{Z_{1A} - Z_{2A}}{Z_{1A} + Z_{2A}} + I_B \frac{Z_{1B} - Z_{2B}}{Z_{1B} + Z_{2B}} + I_C \frac{Z_{1C} - Z_{2C}}{Z_{1C} + Z_{2C}} \quad (34a)$$

Observing the relation between the impedance and admittance one can re-write the above into:

$$I_{DIF} - I_A \frac{Y_{1A} - Y_{2A}}{Y_{1A} + Y_{2A}} - I_B \frac{Y_{1B} - Y_{2B}}{Y_{1B} + Y_{2B}} - I_C \frac{Y_{1C} - Y_{2C}}{Y_{1C} + Y_{2C}} = 0 \quad (34b)$$

Which is precisely the 60N balance equation as derived in section 4.4 (equation (18)).

The above proves, that neglecting CT and relay accuracy the 60P and 60N functions have identical sensitivity. Specifically, per each percent of change in the impedance/capacitance of one of the banks, the differential CT would see an increase of 0.5% of the total bank current.

The phase variant of the method (60P) is easier to compensate for the inherent bank unbalance. The neutral variant of the method (60N) requires 1 CT and relay input, compared with 3 sets for the phase version (60P). If applied concurrently on one relay, the two functions may be treated as partially redundant using different CTs and relay inputs.

## 6. Sensitivity to Instrumentation Errors

This section analyses impact of finite accuracy of Instrument Transformers (ITs) and the relay on the four protection methods.

It is important to notice that errors of instrument transformers and the relay can be accounted for when tuning the coefficients. If the tuning coefficients ( $k$ ) are implemented as real numbers, the magnitude errors can be eliminated, and the impact of angular errors could be reduced. If the coefficients are implemented as complex numbers, both magnitude and angle errors can be accounted for.

However, the IT and relay errors will slightly change with the magnitude of the signal and /or other factors such as residual flux or temperature. Even if tuned at one particular operating point, the method will show some errors at different operating point due to the IT and relay inaccuracies. It is important to realize, though, that these errors occur regardless of the protection principle. By compensating for bank inherent unbalance, and partially for IT and relay errors, the methods presented in this paper are already less susceptible to instrumentation errors. Detailed analysis follows.

Magnitude and angle errors of ITs and the relay can be modeled as a complex multiplier applied for the analysis purposes to the ideal transformation ratio of a given signal. For example, a negative 0.5% magnitude error combined with a 0.3 deg angle error can be modeled as:

$$n_{ACTUAL} = n_{IDEAL} \cdot b, \quad b = (1 - 0.005) \angle 0.3^\circ$$

### 6.1 Impact of Instrumentation Errors on the Voltage Differential Function

For simplicity consider applications on grounded banks. The operating signal in secondary volts is (equation (1c)):

$$V_{OP(A)} = \left| V_{1A} - k_A \cdot \frac{n_{VT2}}{n_{VT1}} \cdot V_{2A} \right|$$

Now assume that the equation was perfectly balanced making the operating signal above a perfect zero, but one of the VTs, say the tap VT (#2), works with an error of  $b$ . If so, the operating signal becomes non-zero:

$$V_{OP(A)} = \left| V_{1A} - k_A \cdot b \cdot \frac{n_{VT2}}{n_{VT1}} \cdot V_{2A} \right| \quad (35a)$$

Assuming a perfect balance, equation (1c) can be solved for the tap voltage:

$$0 = \left| V_{1A} - k_A \cdot \frac{n_{VT2}}{n_{VT1}} \cdot V_{2A} \right| \rightarrow k_A \cdot \frac{n_{VT2}}{n_{VT1}} \cdot V_{2A} = V_{1A} \quad (35b)$$

Substituting (35b) into (35a) yields:

$$V_{OP(A)} = \left| V_{1A} - b \cdot V_{1A} \right| = \left| V_{1A} \right| \cdot \left| 1 - b \right| \quad (35c)$$

Or expressing the error as a proportion of the bus voltage:

$$\frac{V_{OP(A)}}{\left| V_{1A} \right|} = \left| 1 - b \right| \cdot 100\% \quad (35d)$$

For example, with negative 0.5% magnitude error and 0.3 deg angle error, the spurious operating voltage would read:

$$\frac{V_{OP(A)}}{\left| V_{1A} \right|} = \left| 1 - (1 - 0.005) \angle 0.3^\circ \right| \cdot 100\% = 0.72\%$$

The error is at the level that encroaches on the targeted sensitivity settings. Note, however, that this method would accommodate some of the error in the matching factor  $k$ , leaving only a small variable fraction of this error unaccounted for. Assuming 0.15% magnitude error for both the ITs and the relay, and 0.2deg angle error gives 0.38% of bus voltage read as a spurious operating signal.

It is important to understand that the method compares two voltages. Both errors will play a role. They may cancel mutually, or add up.

### 6.2 Impact of Instrumentation Errors on the Compensated Bank Neutral Voltage Unbalance Function

The approach illustrated in the previous subsection applies to this protection method as well. Examining the key operating equation for secondary voltages (7) leads to a conclusion that during normal system conditions four voltage components, each of a very small or zero magnitude, are added as vectors: neutral point bank voltage, system neutral voltage and two phase voltages – the latter two with very small multipliers.

These four voltages are delivered by four VTs: (A,B,C,X) in case of implementation (7a) with internally derived system zero-sequence voltage; and (0,X,B,C) in case of implementation (7b) with externally supplied system zero-sequence voltage. For the purpose of error analysis, each of the VTs shall be represented with its own ratio, potentially slightly different than the nominal value.

When deriving the system zero-sequence voltage internally the three phase voltages are added as vectors – small errors could yield a relatively significant spurious system zero-sequence voltage. The following derivative of equation (7a) is useful:

$$V_{OP} = \frac{1}{3 \cdot n_{VT}} |n_{VTX} \cdot (1 + k_{AB} + k_{AC}) \cdot V_x - n_{VT} \cdot V_A - k_{AB} \cdot n_{VT} \cdot V_B - k_{AC} \cdot n_{VT} \cdot V_C| \quad (36a)$$

For the purpose of error analysis, the  $k$ -factors can be assumed to be unity, and therefore:

$$V_{OP} = \frac{1}{3 \cdot n_{VT}} |n_{VTX} \cdot 3 \cdot V_x - n_{VT} \cdot V_A - n_{VT} \cdot V_B - n_{VT} \cdot V_C| \quad (36b)$$

Assume the above is perfectly balanced and an error in the measurement of the bank neutral voltage is added, represented by the complex number  $b$ :

$$V_{OP} = \frac{1}{3 \cdot n_{VT}} |n_{VTX} \cdot b \cdot 3 \cdot V_x - n_{VT} \cdot V_A - n_{VT} \cdot V_B - n_{VT} \cdot V_C| \quad (36b)$$

From equation (36b):

$$n_{VTX} \cdot 3 \cdot V_x = n_{VT} \cdot V_A + n_{VT} \cdot V_B + n_{VT} \cdot V_C \quad (36c)$$

Substituting (36c) into (36b) gives:

$$V_{OP} = \frac{1}{3} |(b-1) \cdot (V_A + V_B + V_C)| = |b-1| \cdot |V_0| \quad (36d)$$

In other words, the error in the operating signal is proportional to the system unbalance, with a small multiplier. As a result, errors in the measurement of the bank neutral voltage are of secondary importance. For example, assume a system unbalance ( $V_0$ ) of 3% of bus nominal voltage, and a 5% magnitude and 1 deg angle error for the neutral point transformer. Using equation (36d) one concludes that this error introduces about 0.16% of bus nominal voltage as a spurious operating signal.

Bus VTs must be much more accurate to facilitate sensitive protection. Assume, a phase A VT is now exposed to measurement errors:

$$V_{OP} = \frac{1}{3 \cdot n_{VT}} |n_{VTX} \cdot 3 \cdot V_x - n_{VT} \cdot b \cdot V_A - n_{VT} \cdot V_B - n_{VT} \cdot V_C| \quad (37a)$$

From equation (36b):

$$n_{VTX} \cdot 3 \cdot V_x - n_{VT} \cdot V_B - n_{VT} \cdot V_C = n_{VT} \cdot V_A \quad (37b)$$

Substituting (37b) into (37a) gives:

$$V_{OP} = \frac{1}{3} |b-1| \cdot |V_A| \quad (37c)$$

In other words, 1/3rd of the bus voltage “leaks” as a spurious operating signal due to errors in the measurement. For example, assume 0.3% magnitude error and 0.2 deg angle error. These errors in the A-phase voltage with all the other measurements intact, i.e. with errors not adding and not canceling, would yield according to equation (37c) 0.18% of bus voltage as an error in the operating signal of this protection method.

When using externally derived system zero-sequence voltage (equation (7b)), requirements for the bank and system neutral voltage measurements are relaxed, and the accuracy of measurement of the two phase voltages becomes secondary because of the low value of multipliers applied to the B and C voltages.

Generally speaking the method is most impacted by the accuracy of the measurement of the system neutral voltage. This quantity is derived regardless of the method applied (internally, externally to the relay) out of three vectors each having significant magnitude compared with the target sensitivity. Small magnitude and angle errors in sensing any of the three vectors would become significant for this sensitive protection function.

### 6.3 Impact of Instrumentation Errors of the Phase Current Balance Function

When using a window-type CT to measure the differential current, this method is quite immune to instrumentation errors. From equation (12) the method balances the differential current with a small fraction of the total bank current. Both signals are low: the former because of the near-zero circulating current; the latter because of the multiplier. As a result the errors are decimated when they “leak” into the operating signal.

Analysis of equation (12) yields the following expression the error analysis:

$$I_{OP} = |b-1| \cdot |I_{DIF}| = |b-1| \cdot |k| \cdot |I| \quad (38)$$

For example, assume 2% of full bank current circulating in the window CT ( $k = 0.02$ ), and 5% magnitude and 3 deg angle error in the phase CT. According to equation (38) the spurious operating signal will reach 0.14% of the total bank current.

### 6.4 Impact of Instrumentation Errors of the Neutral Current Balance Function

As explained in the previous section, the neutral and phase current balance methods are equivalent. The differential neutral current is compensated for inherent unbalance by all three currents (per equation (18)), but similarly to the phase current balance method the multipliers for the phase currents are small. Therefore, equation (38) applies to this method, and yields the same results as to the impact of measurement errors.

Overall the relative insensitivity of the current balance methods to instrumentation errors can be understood by realizing only small portions of the phase currents are used for compensation, while the differential currents – if measured via window CTs – are not exposed to any significant errors.



## 7. Comparison with Traditional Methods

Traditionally, either a given function is desensitized to account for inherent bank unbalances and instrumentation errors. Or, a historical value of the non-zero operating quantity is subtracted ( $\Delta$ -changes) before comparing with a pickup threshold ( $P$ ) resulting in the rate-of-change mode of operation:

$$\Delta|V_x - V_0| > P \quad (\text{neutral unbalance}) \quad (39a)$$

$$\Delta|I_{DIF}| > P \quad (\text{phase or neutral current unbalance}) \quad (39b)$$

The rate-of-change approach improves sensitivity to some extent but has limitations.

First, it is an approximation. As derived in section 4, the “leaking” values are proportional to present values of some other signals related to the bank (example: differential current in the phase balance method proportional to the total bank current). When the currents do not change, the delta method works satisfactory. But when the currents change, such as during close-in external faults, subtracting an old value will not compensate correctly. Time delay or other inhibit method may be needed to ride through such conditions.

Second, the rate-of-change approach will not provide for a sustained operating signal. When the delta-t window slides entirely into the fault, the operating signal will reset. This creates a problem when time-delayed operation is assumed.

Methods for inherent bank compensation presented in section 4 identify the true cause of the unbalance, and as such are accurate under system balanced conditions, minor unbalances, and major system events such as close-in faults. Their operating signals are sustainable allowing time delayed alarming and tripping with no restrictions.

Major system unbalance is an important condition to consider. For example, assume a close in ground fault elevating both the system zero-sequence voltage and the bank neutral point voltage. The compensated neutral unbalance method is based on equation (5):

$$V_{OP} = \frac{1}{3} |(1 + k_{AB} + k_{AC}) \cdot V_x - 3 \cdot V_0 + V_B \cdot (1 - k_{AB}) + V_C \cdot (1 - k_{AC})|$$

During the outlined ground fault event,  $V_x$  and  $V_0$  assume significant values and will balance perfectly as long as the relay uses proper settings for the inherent bank unbalance compensation ( $k$ -values) and the instrumentation errors are low enough compared with the applied setting. The other two voltage components are of secondary importance as they use small multipliers.

Simplifying one can write the following balance equation for this function:

$$V_{OP} = |V_x - V_0| \quad (40a)$$

In other words, the operating signal is a vectorial difference of two voltages. In order to better cope with errors and avoid penalizing sensitivity an optimized restraining signal can be created as follows:

$$V_{REST} = |V_x + V_0| \quad (40b)$$

Note that the above signal is not a classical restraint in the form of a sum or average of the magnitudes. This would affect sensitivity of the function. Instead the restraint is a vectorial sum of the two voltages.

To understand better how this approach works, consider external fault and internal bank failure.

Assume an external fault producing 20% of system zero-sequence voltage. Assume further, the bank neutral point voltage is measured as  $0.2 pu \angle 0^\circ$  while the system zero-sequence voltage is measured as  $0.17 pu \angle 5^\circ$  due to finite accuracy of instrument transformers and the relay, transients, etc. If so, the function even if perfectly compensated for the bank inherent unbalance would see an operating signal of:

$$V_{OP} = |0.2 pu \angle 0^\circ - 0.17 pu \angle 5^\circ| = 0.034 pu$$

If used to trip instantaneously without a restraint the function will have to be set above this level.

Calculate the proposed restraining signal:

$$V_{REST} = |0.2 pu \angle 0^\circ + 0.17 pu \angle 5^\circ| = 0.37 pu$$

Note that the applied definition of the restraint practically doubles the two involved signals. Assuming a slope is used for tripping, it will take  $0.034/0.37 = 9.2\%$  of slope to restrain the operation.

Consider an internal bank failure under 5% of system unbalance (system zero-sequence voltage). Assume further, the bank failure changes the neutral point voltage by 2% of bus voltage at the angle of 180 deg (worst case):

$$V_0 = 0.05 pu \angle 0^\circ, V_x = 0.05 pu \angle 0^\circ - 0.02 pu \angle 180^\circ = 0.07 pu \angle 0^\circ$$

The operating signal is:

$$V_{OP} = |0.07 pu \angle 0^\circ - 0.05 pu \angle 0^\circ| = 0.02 pu$$

The restraining signal is:

$$V_{REST} = |0.07 pu \angle 0^\circ + 0.05 pu \angle 0^\circ| = 0.12 pu$$

Assume a 10% slope setting is applied. The ratio between the operate and restraining signals is  $0.02/0.12 = 17\%$  allowing for sensitive operation given the slope of 10%.

Change in the voltage at 180 degrees is the worst case. Under the best case scenario one obtains 0.08pu of restraint, or  $0.02/0.08 = 25\%$  of the operate-to-restraint ratio.

Careful application of restraint allows further improvement of security while maintaining good sensitivity of the capacitor bank protection functions.

## 8. Summary

This paper derives correct balance equations for short circuit protection of shunt capacitor banks taking into account inherent unbalances in the protected bank. Four methods are derived: voltage differential, compensated neutral voltage unbalance, phase current balance, and neutral current balance.

As can be seen from key equations (1), (5), (11), and (18) the proper way of balancing the bank (or banks) involves instantaneous values of currents or voltages. Subtracting the residual unbalance as a time-delayed signal (a historical, or a constant value), and responding to the delta changes does not constitute a proper, sensitive and secure operating equation for protective relaying purposes.

The methods presented in this paper compensate for both bank and system unbalances. Therefore they are insensitive to major system events such as close-in faults. Presently used relaying techniques might misoperate on such system conditions, as they typically disregard system unbalances and compensate for the bank unbalance assuming no, or minor system unbalances.

The exact balance equations developed in this paper open a chance to perform manual, or automated adjusting of the operating logic in order to accommodate the inherent unbalance of the bank either due to un-repaired failures, temperature or seasonal changes, or changes due to removing, shorting, or repairing the cans. This can be done as auto-setting, i.e. one time adjustment after the repair and under user supervision, or as self-tuning, i.e. a continuous tracing of the slightly changing capacitor reactances in order to maintain optimum sensitivity to internal failures, and security during system unbalances.

The voltage differential, phase and current balance methods are subject to self-tuning under any conditions; the neutral voltage unbalance is subject to self-tuning as long as the neutral point voltage is above the measuring error level. When applied in the self-tuning mode the methods continuously compensate for temperature and seasonal changes, in a slow loop of modifying their balancing coefficients based on actual values. Note that the majority of the balancing coefficients developed in this paper are ratios of impedances. As such they are already greatly insensitive to temperature and seasonal changes.

If implemented in the self-tuning mode a given method shall still monitor the total drift in the operating signal even if very slow, and alarm if the amount of the drift signifies a danger of possible future failure, or a series of minor failures that went undetected or unattended to.

The involved balancing factors although in theory are complex numbers, could be very well represented by real numbers (uneven loss tangents of the capacitors in the bank, and errors of instrument transformers cause small imaginary parts of the matching factors). With the matching factors being real numbers, inherent unbalance of a capacitor bank can be easily zeroed out in the protection equations using only 1, 2 or a maximum of 3 coefficients. These coefficients can be tuned by measurements, and simple engineering calculations.

The paper analyses sensitivity of the developed methods and derives practical equations for the amount of the operating signals given the size of the bank failure. Also, impact of instrumentation errors (instrument transformers and relays) is analyzed quantitatively allowing one to optimize the secondary system design, and select settings based on data.

## 9. References

- [1] IEEE Std. C37.99-2000: "Guide for the Protection of Shunt Capacitor Banks", June 2000.
- [2] Kasztenny B., Brunello G., Wester C.: "Capacitor Bank Fundamentals and Protection", Proceedings of the 56th Annual Conference for Protective Relay Engineers, College Station, TX, April 8-11, 2003.
- [3] Capacitor Bank Protection and Control Relay, Instruction Manual, General Electric Publication, 2006.