

# Status on the First IEC61850 Based Protection and Control, Multi-Vendor Project in the United States

Craig Wester  
GE Multilin

Drew Baigent  
GE Multilin

Juergen Holbach  
Siemens

Julio Rodriguez  
Siemens

Lars Frisk  
ABB

Steven Kunsman  
ABB

Luc Hossenlopp  
AREVA

## 1. Abstract

The new IEC61850 substation communication standard is almost two years old. Worldwide, there are already over one hundred substations that have been commissioned and running with this new standard. Several projects in North America have been implemented with IEC61850 by using products from a single manufacturer. This paper will report on the status of a 500KV project, which is the first multi-vendor project in the United States to use this new standard. The goal of the project is to utilize the new IEC61850 standard to its fullest (as practically possible) therefore confirming that the standard is much more than just a communication protocol. Interoperability, one of the major advantages of IEC61850, will be demonstrated. The focus of the paper is not to describe or explain the theoretical background of the standard itself but rather to show and demonstrate the practical use of an actual multi-vendor project and how the standard applies to protection engineers. In addition, the paper will describe to the relay engineers that an IEC61850 based system must be considered an integral part of the protection and control system and not just another protocol integration for substation data/automation.

The paper will describe the process that was developed and used during this project to configure the IEDs, clients, and the communication infrastructure as defined by the customer. The exchange of IED configuration data between different vendors was achieved by using the IEC61850 defined Substation Configuration Language (SCL). We will demonstrate how each vendors private tools can export data into a standard format and be integrated into a common product using standard tools as well. The meaning and the purpose of the standard ICD files (IED Capability Description) and SCD files (Substation Configuration Description) will be explained.

One goal of this project is to eliminate or significantly reduce wiring between the relays and between the control house and the breakers. The wire reductions are replaced with the communication infrastructure fulfilling the protection and control applications by exchanging IEC61850 GOOSE messages over Ethernet (e.g. breaker position and protective trips).

The paper will also cover test tools and procedures that were used to find and eliminate problems during the integration of the protection & control system and the new IEC61850 standard. Lessons learned throughout the project will be discussed.

## 2. Introduction

Tennessee Valley Authority (TVA), a major transmission and generation utility in North America, designed a 500kV-to-161kV substation to integrate the IEC61850 communication standard across all protection & control IEDs within the substation, with the exception of one IED. This project brought together several manufacturers (Siemens, GE Multilin, ABB and AREVA) to accomplish this task. Protection, control and communication engineers from Siemens, GE Multilin, ABB and AREVA have worked on this project since late 2004/early 2005 and have been actively involved with the streamlined design using the IEC61850 standard. The project name is the "Bradley 500kV Substation" and its location (just outside Chattanooga, TN) is shown in Figure 1.

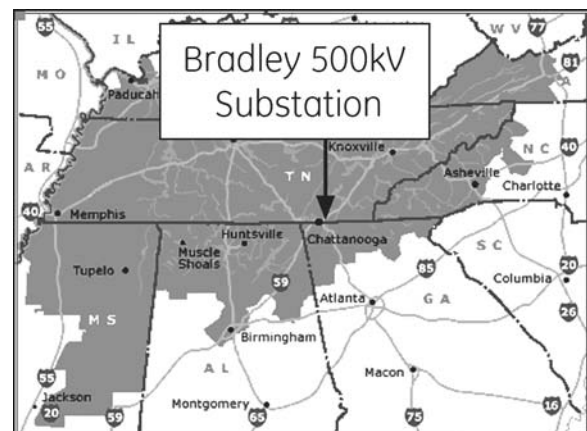

Figure 1.  
Substation Location

The Tennessee Valley Authority, set up by the U.S. Congress in 1933, is a federal corporation and the nation's largest public power company with 33,000 megawatts of dependable generating capacity. TVA's power system consists of a diverse mix of fuel sources, including fossil, nuclear, hydro, and renewables. TVA has eleven coal fired plants, three nuclear plants, 29 hydroelectric plants, six combustion turbine plants, one pumped storage plant, 17 solar power sites, one wind-power site, and one methane gas site. Coal plants typically provide about 60 percent of TVA's power. TVA supplies power through a network of 17,000 miles of transmission line, 117,000

transmission structures, and 1,025 interchange and connection points. TVA sells power to 158 local distributors that serve 8.6 million people and 650,000 businesses and industries in the seven-state TVA service area. TVA also sells power to 61 large industrial customers and federal installations. TVA covers almost all of Tennessee and parts of Alabama, Georgia, Kentucky, Mississippi, North Carolina, and Virginia.

An excellent group of TVA personnel made this Bradley project a success. Jim Kurtz, Manager of Protection & Control at Tennessee Valley Authority, had the following comments on the project:

*"I am very proud of the effort by all concerned on the project. I believe the industry is about to see a transformation that will improve operation, maintenance, and reliability while at the same time reducing the cost for design, construction, and maintenance."*

*I cannot stress how important collaboration like this is to the industry. For our suppliers to work together to resolve issues will help not only the suppliers provide a better product but also a product that will meet the long term needs of the industry.*

*While this effort has leaped TVA forward in technology, we still have work to complete. The process bus needs to be proven and the tools to provide interoperability need to be much easier to use to accelerate the application of the standard."*

In addition, Craig McClure, Senior Design Engineer at Tennessee Valley Authority, had the following comments on the project:

*"Teamwork was the most important factor to achieve success on the project. Engineering barriers did not exist. The team provided a complete Protection and Control system. With just a bit more product and programming tool maturity, we will be able to do more for less and save significant money on the life cycle cost of a substation."*

### 3. Substation Design & Layout

The Bradley substation incorporates the IEC61850 part 8-1 station bus standard utilizing Logical Nodes and the GOOSE messaging for all protection & control for 500kV & 161kV transmission lines and breakers, transformer "A" set protection, data acquisition of the transformer, transformer LTC control, breaker control, supervisory control & data acquisition (SCADA), operational interface panels (OIP), digital fault recorder interface and miscellaneous station data.

The IEC61850 IEDs used in the final design of the Bradley Substation are shown in Figure 2. Thirty-three (33) IEDs make up the IEC61850 implementation of this project.

- Line protection relays LA99A, LB99A, 9A99A, 9299A & 9B99A are GE-Multilin D60 relays (GE-D60).
- Line protection relays LA99B, LB99B, 9A99B, 9299B & 9B99B are ABB REL 670 relays (ABB-REL 670).
- Breaker control devices LA52BCA, LA52BCB, L252BCA, L252BCB, LB52BCA, LB52BCB, 9152BCA, 9152BCB, C1652BCA, C1652BCB, 9A52BCA, 9A52BCB, C2652BCA & C2652BCB are Siemens 7SJ64 relays (SIEMENS-7SJ64).
- Transformer protection relay 87A is GE-Multilin T60 relay (GE-T60).
- LTC control and transformer monitoring 30TA, 30TB, 30TC & 30TS are GE-Multilin C30 relays (GE-C30).
- 30SHA - Set "A" substation alarms and auxiliary control logic is GE-Multilin C30 relay (GE-C30).
- 30SHB - Set "B" substation alarms and auxiliary control logic & IEC61850 interface to set "B" transformer protection is ABB REC 670 relay (ABB-REC 670).

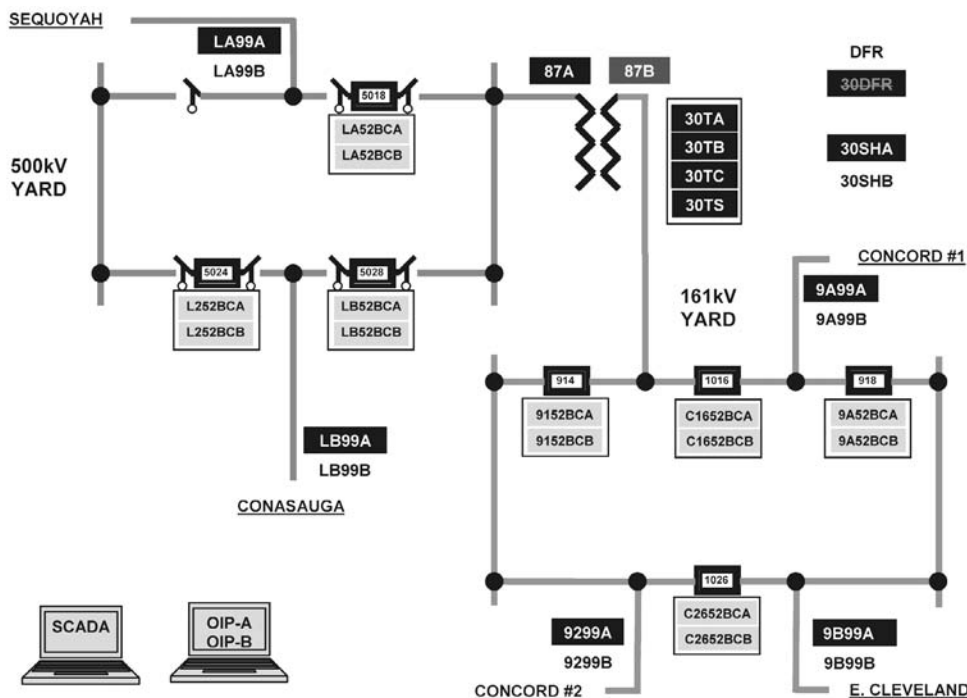

**Figure 2.**  
Bradley Single Line (initial configuration)

- Digital fault recorder IEC61850 interface 74FRX is GE-Multilin C30 relay (GE-C30)
- SCADA gateway IED with both the station HMIs (OIP-A & OIP-B) graphical interface software are Siemens PAS system (SICAM PAS).

## 4. Protection & Control Scheme

Redundant protection, a TVA core protection requirement, is applied on all 500kV & 161kV transmission lines & breakers and three single-phase 500/161/13kV power transformers within substation.

### 4.1 Transformer Protection

Two complete, comprehensive and independent transformer protection packages/schemes are implemented. The transformer bank is a wye-wye-delta (500/161/13kV) with a 1200 MVA capacity through the use of four single-phase transformers (one is a spare). Set "A" protection (GE-T60) provides transformer differential protection, over current protection, transformer sudden pressure protection, hot spot protection, LTC sudden pressure protection and restricted ground fault (RGF) protection for both neutral CT's. Every transformer status and alarms, such as fan status, liquid levels, etc. are collected by the 30TA, 30TB, 30TC & 30TS devices (GE-C30), which are located in cabinets mounted on each of the four single-phase 500/161/13kV transformers. Analog and digital data from 30TA, 30TB, 30TC & 30TS IEDs are available in IEC61850 format to OIP-A, OIP-B and SCADA. All trip cut-out switches and lockout relays (LORs) for "A" set transformer protection are considered virtual and resident within the 87A IED logic. These virtual switches can be manipulated from OIP-A, OIP-B, SCADA or 87A front panel pushbuttons. LEDs and virtual LEDs on the OIP provide various system conditions relating to a complete transformer bank protection scheme. The 87B device is a non-IEC61850 IED using a conventional LOR (lock out relay) and hard-wire trips.

### Typical transformer fault scenario

**Condition: An internal fault to the transformer has occurred. What happens?**

"A" set - The 87A IED determines a fault condition. Depending on the virtual 29DA trip cut-out switch (in the "ON" position), the 87A IED will issue a GOOSE message ("bank differential set "A" operated"). This GOOSE message will be used by each of the eight 52BC IEDs (SIEMENS-7SJ64) – LA52BCA, LA52BCB, LB52BCA, LB52BCB, 9152BCA, 9152BCB, C1652BCA, C1652BCB) to trip & lockout individual breakers & open corresponding isolating switches. The same GOOSE message will also initiate breaker failure protection within "A" set line/breaker IEDs (GE-D60) – LA99A, LB99A, 9299A, 9A99A. When a transformer fault condition is detected the 87A will also simultaneously close its output contacts (for risk management purposes), which are directly connected to trip the four breakers involved in the transformer differential zone of coverage.

"B" set - The 87B relay determines fault condition and closes its trip contact on the I/O board. This contact is in series with the 29DB trip cut-out switch (in the "ON" position) which energizes the 94B LOR. The 94B device has contacts wired directly to trip the four breakers involved in the transformer differential zone of coverage. The 94B also has a contact wired into the 30SHB device (ABB-REC 670) to indicate the transformer fault condition ("bank differential set "B" operated") to other IEC61850 IEDs, SCADA & local OIP-B. The 30SHB will then issue a GOOSE message to initiate breaker failure within "B" set line/breaker protection IEDs (ABB-REL 670) – LA99B, LB99B, 9299B, 9A99B for a transformer fault condition.

### 4.2 Line Protection

Line protection relays LA99A, LB99A, 9A99A, 9299A & 9B99A are GE-Multilin D60 relays and line protection relays LA99B, LB99B, 9A99B, 9299B & 9B99B are ABB-REL 670 relays (see Figure 3).

The ABB-REL 670 and the GE-D60 relays are used for all line protection requirements, which include distance/pilot protection, directional ground overcurrent, synchrocheck,



**Figure 3.**  
"A" Set and "B" Set Protection

breaker failure and reclosing. The additional pilot teleprotection IEDs include the Pulsar UPLC (block/unblock) and the RFL Gard8000 (POTT). The Sequoyah 500kV line has individual POTT schemes for both line protection relays. The Conasauga 500kV line has the GE-D60 IED using an unblocking scheme and the ABB-REL 670 IED using a blocking scheme. On each of the 161kV lines, both line protection systems will share a single RFL Gard8000 for its POTT scheme. Each line relay is operating in a breaker & ½ topology, such that two breakers are connected to each line relay with independent breaker currents and line & bus voltages wired.

Virtual selector switch logic for all line protection scheme and pilot enhancement packages (GE-D60 and ABB-REL 670 IEDs) has been implemented. The use of virtual selector switch logic within line relays streamlines the panel design and eliminates the need for external control switches. These virtual selector switches can be manipulated by the OIP, SCADA or IED pushbuttons/HMI. Each line relay is operating in a breaker & ½ topology and apparatus virtual switches are doubled providing a streamlined design.

### Selector switch for group control – impedance relay

- Position 1 – Group protection setting 1
- Position 2 – Group protection setting 2
- Position 3 – Group protection setting 3
- Position 4 – Group protection setting 4

### Selector switch for pilot scheme

- Position 1 – OFF
- Position 2 – ON
- Position 3 – TEST-SEND (test send a “permission to trip” or test send a “block trip” or test send “unblock trip” depending on scheme being used).
- Position 4 – TEST-SEND LRS (test send a low level signal of the same type commands listed under position 3 above. Even though all IEDs are equipped with this standard control scheme in its logic, it is only used for the Conasauga 500kV line only).

### Other front selection switches include:

- IED Remote/Local for OIP or SCADA control (From a relay logic perspective, this is the only virtual control switch that can not be controlled by SCADA).
- Transfer Trip Receiver (TT RCVR) to select different receiver options (OFF, ON, TEST)
- Transfer Trip Transmitter (TT XMTR) to select TT TEST-SEND or not.

- Breaker X Master Reclose (BKR X – RCLS MASTER IN/OUT) – enables/disables reclosing (IN, OUT).
- Breaker X Breaker Failure Trip-Cut-Out (BKR X FLR TCO IN/OUT) – disables breaker failure functions (IN, OUT)
- Breaker X Reclose Option (BKR X – RCLS OPTION) to select different reclose & synchrocheck options (3 position for a 500kV application and 7 position for a 161kV application)
- 161kV Breaker X Third Shot Reclose Option to select the third shot reclose options (IN/OUT).
- Breaker X Maintenance (BKR X – MAINTANANCE IN/OUT) – this feature sends “out of service” GOOSE message out to associated 52BC IEDs and block manual control of breaker via 52BC IED.
- LOR MASTER RESET is used in conjunction with GOOSE messaging from IED 30SHA or 30SHB which indicate the virtual LOR may be reset.
- Breaker Control
- Isolating MOD Control

Line relays exchange IEC61850 GOOSE messages for reclose cancel conditions and reclose enabled/disabled conditions.

Each line IED obtains status & alarm information from breaker control IEDs (SIEMENS-7JS64) within substation yard via IEC61850 GOOSE messages:

- Breaker position
- MOD ISO position
- Line ground switch position
- Breaker control position (CLOSE-NAC) – a virtual position from logic within 52BC device that aids in reclosing
- Low low gas – arm breaker failure (161kV breakers only) – used to by-pass the breaker failure timing circuit in 161kV applications.

For example:

- Line relay LB99A receives breaker 1 (5028) information from LB52BCA & LB52BCB and breaker 2 (5024) information from L252BCA & L252BCB.
- Line relay 9299B receives breaker 1 (914) information from 9152BCA & 9152BCB and breaker 2 (1026) information from C2652BCA & C2652BCB.

The line relays send the following IEC61850 GOOSE messages to associated 52BC IEDs (SIEMENS-7SJ64):

- Protective trip breaker
- Auto-reclose breaker



- Breaker failure trip & lockout
- Transfer trip & lockout
- Manual trip breaker
- Manual close breaker
- Manual trip motor operated disconnects (MOD)
- Manual close motor operated disconnects (MOD)

Breaker out-of service (disable control of breaker via 52BC IED)

The only hardwire status input to each line relay is the breaker position statuses and this is only used if a digital IEC61850 state from either 52BCA or 52BCB devices are not available. A hardwire trip output from the line IED is wired directly to the breaker 1 and breaker 2 trip coils (for risk management purposes). With experience, future designs may provide the substation engineer the option to eliminate these hardwire inputs and outputs and to strictly use the GOOSE functionality.

### Typical line fault scenario:

**Condition: A line fault condition is present.**

**What happens?**

Both the GE-D60 and ABB-REL 670 IEDs determine a fault is present. Both IEDs issue a GOOSE command for all associated 52BC IEDs (SIEMENS -7SJ64) to trip (trip both trip coils within a single breaker). Simultaneously, each line protective relay closes their own trip contact (for risk management purposes) that is parallel wired directly to the breaker trip coil [only TC1] serving that line. If auto-reclose is enabled, the GE-D60 will issue auto-reclose breaker GOOSE messages to the associated 52BC IEDs. If the GE-D60 is considered failed via its power supply failure contact, the ABB-REL 670 relay will assume command and issue the same type GOOSE message. Also, each GE-D60 & ABB-REL 670 will initiate its own breaker failure scheme internally. That is, the GE-D60 initiates the breaker failure logic within its own box and likewise for the ABB-REL 670 (in some situations dictated by station topology, this breaker failure initiate command may be sent out as a GOOSE message to a corresponding device). If breaker failure is declared, then a breaker failure GOOSE message will be issued by line relay to associated 52BC IEDs to trip and lockout until a reset condition is given (reset when affected breakers are green flagged via manual trip operation of line relay) – see breaker control section for more details.

### 4.3 Transformer LTC Control

The substation transformers have a Load Tap Changer (LTC) for each of the four single-phase 500/161/13kV transformers (A, B, C, spare). Each LTC has controls enabling SCADA or OIP (via 30TA, 30TB, 30TC & 30TS IEDs) to raise or lower its tap position. These controls are in addition to the individual transformer LTC controls provided by the manufacturer.

With the transformers all being single phase units, each phase must have controls providing group and individual capability. This dual requirement is met by incorporating a five position selector switch (A, B, C, S & Group) logic in each 30TA, 30TB, 30TC & 30TS IEDs (GE-C30). The position of the virtual switch supervises the raise & lower commands sent to various LTC control units. That is, the OIP or SCADA will have the option to select which tap changer is to accept the raise/lower singular command submitted by the OIP-A, OIP-B and SCADA.

### 4.4 Breaker Control

Breaker control devices LA52BCA, LA52BCB, L252BCA, L252BCB, LB52BCA, LB52BCB, 9152BCA, 9152BCB, C1652BCA, C1652BCB, 9A52BCA, 9A52BCB, C2652BCA & C2652BCB are Siemens 7SJ64 relays (see Figure 4).

The substation contains redundant breaker control devices. The idea behind dual breaker control IEDs is to meet the same redundancy requirement as for line protection. The IEDs as shown in Figure 2 have generic names 52BCA and 52BCB. This defines a breaker (52) IED providing breaker control (BC) and which set (A or B) it corresponds. These devices are mounted inside an enclosure located on the breaker mechanism leg. This enclosure will be referred to as an IED auxiliary cabinet. The individual breaker’s mechanism or control cabinet will be referred to as the main cabinet. Each breaker control 52BC IED will “listen” for a GOOSE message requesting their breaker or MOD to be operated.

Along with the breaker control IEDs, other components and devices will also be located in the IED auxiliary cabinet. They include a temperature thermostat, auxiliary cabinet heater, condensation monitor and an on-line breaker monitor.



**Figure 4.**  
*Breaker control IEDs*

The breaker control IED (SIEMENS-7JS64) within the substation yard sends the following information to the line relays using IEC61850 GOOSE messaging:

- Breaker position
- MOD ISO position
- Line ground switch position
- Breaker control position (CLOSE-NAC) – a virtual position from logic within 52BC device to aid in reclosing
- Low low gas – arm breaker failure (161kV breakers only) – used to by-pass the breaker failure timing circuit in 161kV applications.

The breaker control IED (SIEMENS-7JS64) located in the IED auxiliary cabinet in the substation yard receives the following control messages from each line relay (GE-D60 and ABB-REL 670) located in the control house using IEC61850 GOOSE messaging and operates the associated output contact:

- Protective trip breaker
- Auto-reclose breaker
- Breaker failure trip & lockout
- Transfer trip & lockout
- Manual trip breaker
- Manual close breaker
- Manual trip motor operated disconnects (MOD)
- Manual close motor operated disconnects (MOD)
- Breaker out-of service (disable control of breaker via 52BC IED)

In addition to providing functionality that will monitor & operate high voltage circuit breakers and motor operated disconnect switches (MOD), each 52BCA and 52BCB IED performs several additional tasks. These include energizing/de-energizing the cabinet (main and auxiliary) heaters based on temperature or condensation, cycling of the heaters based on run-time, providing the breaker interlocking/blocking IEC61850 feature, virtual breaker control position, virtual breaker MOD control position and breaker alarm (logic within 52BC device based on hardwire inputs from breaker).

Each 52BC device builds its own lockout bus based on all associated virtual LORs which prevents the breaker from being closed. The breaker may also be “blocked” from accepting manual commands should the “out of service” GOOSE message be received from either line relay.

If a transformer fault occurs, a latch is set within 87A and 30SHB (for 87B) that issue IEC61850 GOOSE messages to the 52BC IEDs of the four breakers involved in the transformer differential zone of coverage disabling the ability to close the breakers until reset GOOSE messages are sent by 30SHA and 30SHB IEDs. The reset bus logic resides within the 30SHA and 30SHB devices. For this particular fault condition, a reset will occur within 30SHA or 30SHB IEDs when the breaker (set “A” and “B”) virtual breaker control position (logic within 52BC IEDs) has been set to TRIP/NAT (normal after trip) by manually tripping each of the line relays via front HMI or OIP that were associated with the event. The reset condition will be sent by IEC61850 messaging by 30SHA and 30SHB IEDs.

If a line relay breaker failure or transfer trip lockout has occurred, a non-volatile latch is set within line relay and IEC61850 GOOSE messages are sent to the associated 52BC IEDs disabling the ability to close the breaker until reset GOOSE messages are sent by 30SHA and 30SHB IEDs. Similar to a transformer fault, a reset will occur within 30SHA or 30SHB IEDs when the breaker (set “A” and “B”) virtual breaker control position (logic within 52BC IEDs) has been set to TRIP/NAT (normal after trip) by manually tripping each of the line relays via front HMI or OIP that were associated with the event. The reset condition will be sent by IEC61850 messaging by 30SHA and 30SHB IEDs.

#### 4.5 Substation Alarms & Auxiliary Control

Individual relay trouble alarms and breaker alarms are collected by the 30SHA (GE-C30) and 30SHB (ABB-REC 670) IEDs. As described above, the reset logic for a transformer fault, line relay breaker failure and line relay transfer trip resides within the 30SHA and 30SHB devices. A reset will occur within 30SHA or 30SHB IEDs when the breaker (set “A” and “B”) virtual breaker control position (logic within 52BC IEDs) has been set to TRIP/NAT (normal after trip) by manually tripping each of the line relays via front HMI or OIP that were associated with the event. The 30SHA and 30SHB IEDs issue IEC61850 GOOSE messages to pertinent line and transformer relays. The reset condition will be sent by IEC61850 messaging by 30SHA and 30SHB IEDs.

#### 4.6 Substation DFR Interface

Device 74DFRX (GE-C30) is the interface between the digital fault recorder (DFR) and specific IEC61850 status and trip conditions of the IEC61850 IEDs within the substation. Contact outputs of the 74DFRX are wired to inputs of the DFR. Future substation designs will eliminate the DFR.

### 5. Network Connections

All IEC61850 IEDs are connected via 100Mbps multi-mode fiber cables to Ethernet switches located in the control house. VLANs are used within the IEC61850 GOOSE message configuration of each IEC61850 device to provide security within the network. Figure 5 shows a conceptual layout of the network and Figure 6 shows a detailed layout of the network.

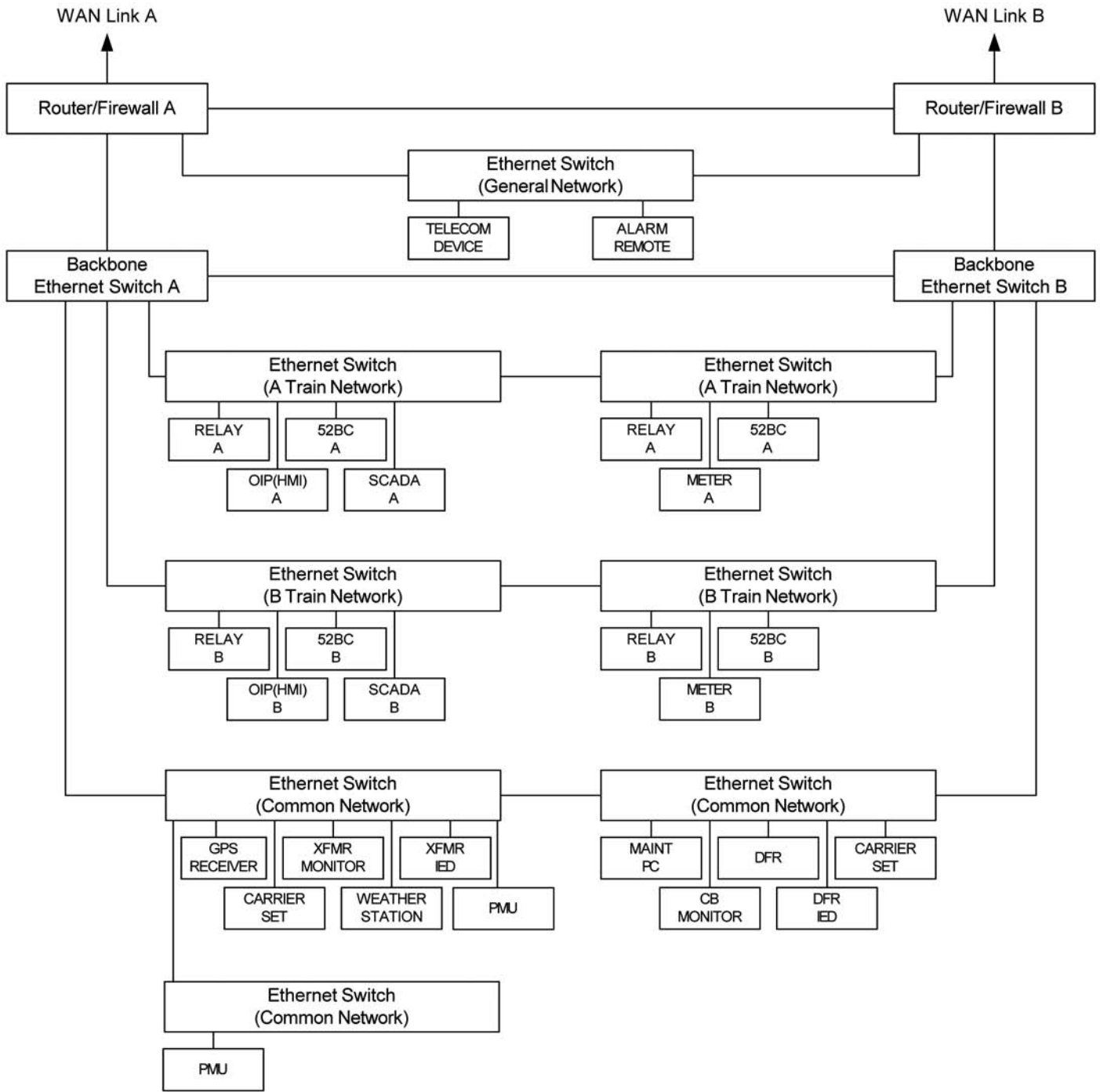

**Figure 5.**  
*Conceptual Network Layout*

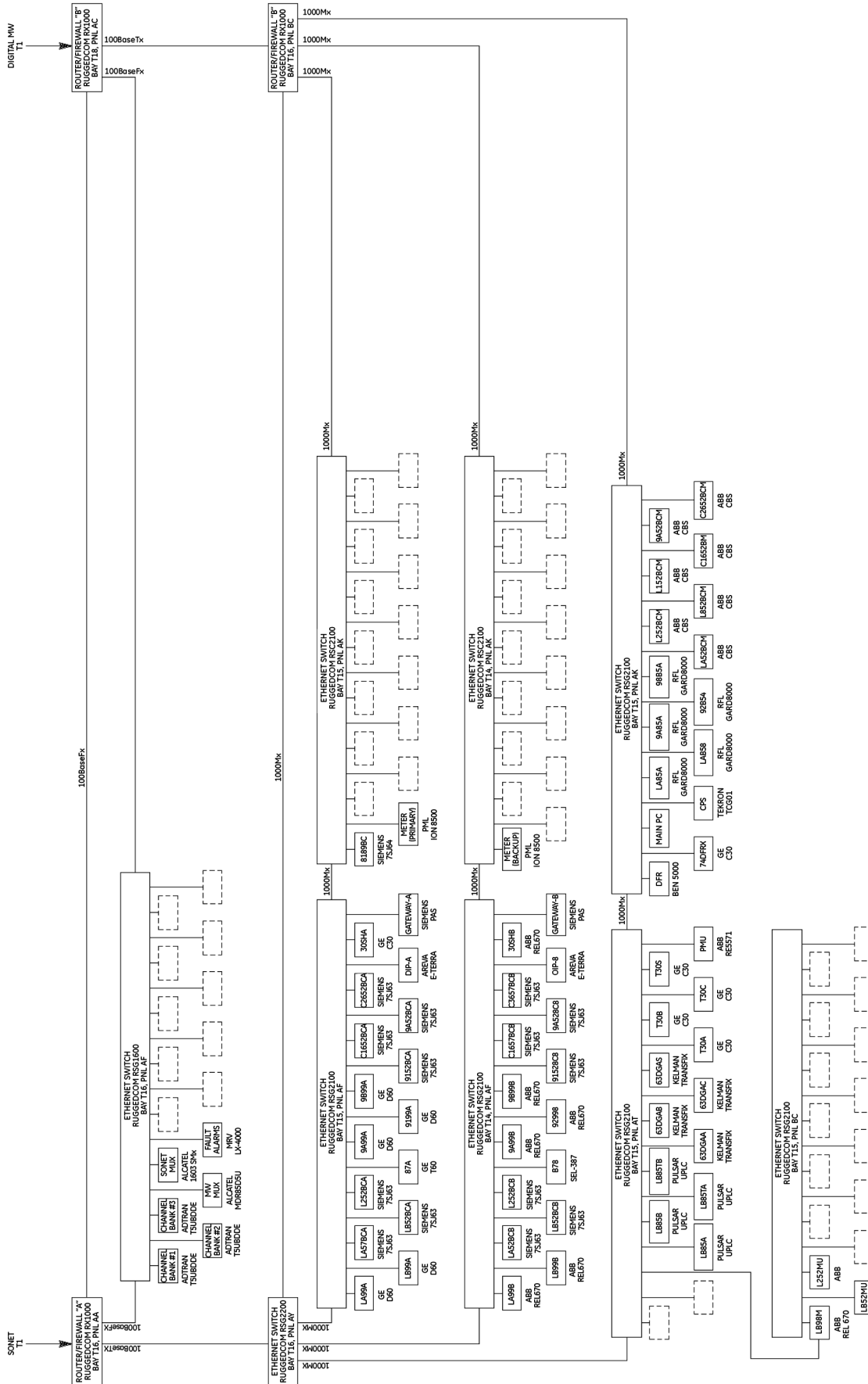

Figure 6.  
Detailed network layout



## 6. Customer/Project Expectations

A goal of this multi-vendor project was to utilize the new IEC61850 standard to its fullest, as far as possible. Some of the key customer/project expectations were/are:

- *Open system for protection, control and data collection from any IED.*
- *Interoperability between IEDs for protection & control functions.* Ability to configure IEC61850 system with available manufacturer tools without need for on-site manufacturer support.
- *Comparable functionality with streamlined design.* Eliminate panel control switches and lockout relays and incorporate functionality into IEC61850 IEDs. This dramatically reduces the panel layout design and allows for a smaller control house (about ½ the size vs. traditional design). For example, consider just one set of protection, up to 12 breakers can be protected and controlled using one single 19" wide panel versus older designs with 1 breaker per panel with both Set A and Set B protection systems. Standard panel designs for any application can be created.
- *Accommodate multiple vendor IEDs*
- *Comparable performance time*
- *Secure & dependable overall system.* Timely, secure flexible information transfers.
- *Flexible management/operation*
- *Economically viable solution*
- *Common technology infrastructure*
- *Reusable practices.* Project established foundation of new substation practices oriented around IEC61850 and new procedures. Business case can be made for wholesale refurbishment with these new practices.
- *Effective data management system*
- *Reduced wiring, installation costs.* Besides the CT & PT wiring from switchyard breakers and motor operated disconnects, only breaker status and breaker trip wiring has been implemented. No inter-wiring exists between any of the IEC61850 IEDs.
- *High-speed local and remote downloads to IEDs over network*
- *Improved Operations & Maintenance from remote and local monitoring & diagnostics via network to reduce service time*
- *System health/status monitoring*
- *Status communications between IEDs*

- *Testing methodology* New test plan and methodology needed to match systems new capabilities and plan to implement test cases. Ability to individually test any IED without the concern of operating other IEDs via network.

## 7. On-site Lab Workout Sessions & Configuration Tools Used

In August 2005, the TVA IEC61850 "project team" met for the first time to begin the process of designing the first US - IEC61850 high voltage substation. The team consisted of four major relay vendors and TVA representatives from their relay and communication engineering departments. Besides all interoperability demonstrations organized previously by the UCA International Users Group or by CIGRE, the team's objective for this project was to show that each relay vendor demonstrate interoperability of the protection and automation devices from design to implementation in real life.

During the IEC61850 integration process, there were three primary tests at the TVA "test lab" substation which the four relay vendors participated. The tests were defined with the purpose of demonstrating that TVA could take the primary lead of configuring their substation with the available IEC61850 configuration tools using the manufacturers in a support role. This would be the first IEC61850 project where the customer would do the system engineering and IED integration and not the relay manufacturer. The integration during previous interoperability tests on other projects throughout the world had been implemented by members of the relay vendors development department using tools and programming language that were not always accessible or available for use by the customer. All participating vendors had previous experience with commissioning several IEC61850 based substation worldwide, but in almost all cases one of the vendors was the integrator and mainly used their own products, engineering tools and integration procedure to configure a substation. The integration of these previous projects was simpler because interpretation of the IEC61850 standard was uniquely confined to that vendor's system architecture and product implementation. It is also important to note that trade show interoperability testing only covers a small portion of the functionality required for a complete substation solution. So, the TVA project in this respect was completely different from previous projects and the trade show interoperability tests. TVA was the system designer and system integrator and they would use the available and released IED tools from each vendor and they would rely on unique interpretations of the new IEC61850 standard by each vendor.

### 7.1 Configuration Tools, ICD and SCD Files

During the first test meeting (August 2005) the "project team" met, the primary goal was to configure all GOOSE links between the relays from the different manufacturers and to reach a minimal level of device interoperability. The procedure to

achieve this is shown in Figure 7. All manufacturers had to supply an ICD file (IED Capability Description) that described the ability of the relays in a standard IEC61850 format. This ICD file is the interface between the relay manufacturers IEC61850 tools and the IEC61850 world. With the ICD files available, the customer can use any independent IEC61850 System Configuration tool to import the ICD files from each relay vendor and configure the system. Once the IEC61850 station is configured, a SCD file (Substation Configuration Description) can be exported describing the station in a standard format defined in IEC61850.

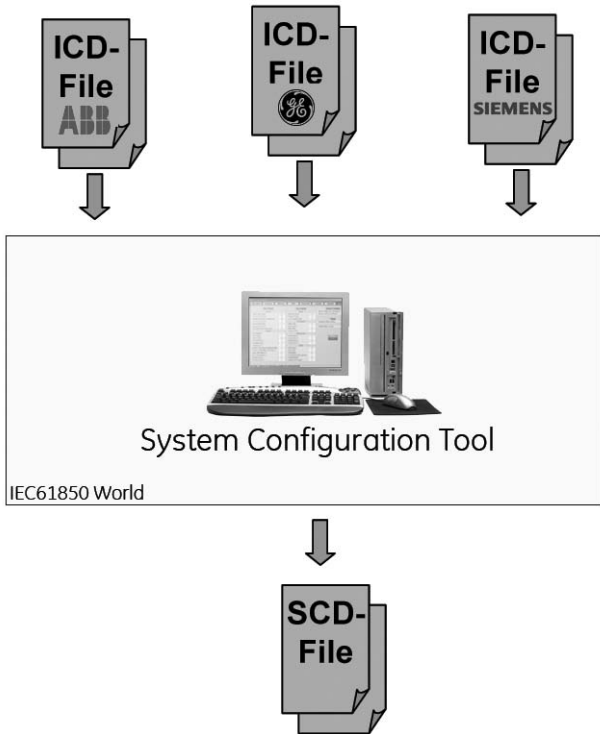

**Figure 7.**  
*IEC61850 File Standards*

The relay vendors must be able to use their proprietary tools to extract the information inside the SCD file which is needed to configure the individual relays of the different relay manufactures. TVA decided to use the DIGSI software from Siemens as the System Configuration tool. When the design process began on the TVA project, the Siemens – DIGSI tool was the only commercially available IEC61850 station configuration tool with all the required functionality.

## 7.2 Lessons Learned & Testing Tools Used

During the first test meeting (August 2005), there was a significant amount of discussion on the details of how the team wanted to achieve their goal. One discussion was centered around what type of GOOSE message should be used. The question of whether TVA wanted to use the GOOSE message implemented in UCA – called GSSE which is defined in IEC61850 to provide compatibility with UCA 2.0 implemented substations, or did they want to use the real IEC61850 GOOSE message – called GOOSE. After evaluation of all pros and cons, the decision was made to use the IEC61850 GOOSE message because of the advantages this new implementation has to offer.

There were also discussions that made it apparent that all relay vendors did not fully understand the power of the new standard. For example, it was thought that it was necessary to manually configure which information in a GOOSE message was to be sent first, the data information or the quality information. It was discovered that different manufacturers and sometimes, different relays from the same manufacturer did it differently, so there was a fear that the information may get misinterpreted. After a lot of discussions and phone calls, the team determined that the order of the information and quality data did not matter as long as it declared in the ICD file. The receiving relay will get the information because it is defined via the SCD file and it knows how to process the information correctly.

During this first test meeting (August 2005), most relay vendors did not have their tools ready to automatically export and import from their proprietary programming tools to the IEC61850 world via ICD and SCD files. This resulted in a significant amount of manual programming work. To validate the correctness of the ICD file, the team used the DIGSI System Configurator as well as the IEC61850 Validator tool. It was determined initially that some of the ICD files had some format errors and during the import of the files, an IEC61850 Validator tool produced error reports as shown below (see Figure 8). These errors were the first hurdle that had to be resolved.

Even though the validation of the ICD files could verify the correct syntax of the file, it could not check for the semantics. Once we were able to import the ICD files and use the System Configurator tool to configure the required system, in some cases, we were not able to receive the programmed GOOSE message because the GOOSE message description was different than what was actually described in the ICD file. To analyze problems where one relay vendor claimed that they

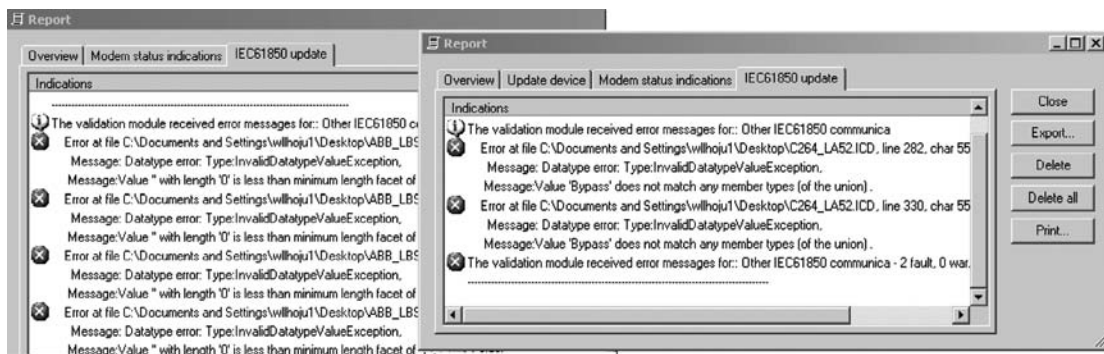

**Figure 8.**  
*IEC61850 Validator Tool*

were sending a GOOSE message and the receiving vendor did not receive, the team used the network protocol analyzer tool Ethereal® with the MMS decoder functionality. Ethereal® allowed for the entire GOOSE structure to be displayed, so that a view of the specific relay IED including the value of the data and quality information could be analyzed (see Figure 9).

By using Ethereal®, we were able to see where adjustments were necessary and finally all GOOSE messages were sent and received correctly between IEDs of the different relay manufacturers. The goal for the test week was achieved and the concept of IEC61850 was proven powerful. Even with this accomplished, configuration of the TVA system was not simple. However, the tools available would allow the customer to configure the system by themselves. During the design process, there were several firmware updates, patches and discussions between the development departments of each of the relay manufacturers. Without the great teamwork between all the manufacturers and the deep knowledge of the implementation details of IEC61850, the interoperability goal could not have been achieved. Initially, it was clear that this was not a practical procedure that a utility could use to configure their IEC61850 substations.

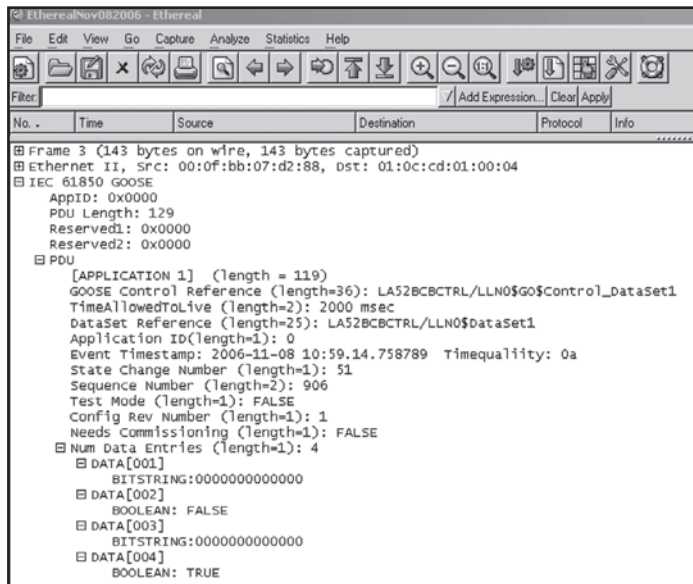

**Figure 9.**  
IEC61850 GOOSE message using Ethereal®  
(Ethereal is a registered trademark of Ethereal, Inc.)

The second test week was conducted in January 2006. The goal was to have TVA configure the system with as little as possible support from the relay manufacturers. The goal of TVA was to be the system designer and integrator. We have to admit that this goal was not achieved, because again some of the manufacturers tools were still not mature enough to allow the customer goal of system integration responsibility. A lot of manual work was still required and a special IEC61850 knowledge was also necessary in order for the correct ICD files to be generated and extracted out of the SCD file for configuring each IED. With support of the relay manufacturers, the system was successfully working and configured at the end of the week, but the actual goal was not achieved. At the end of the second

test meeting, TVA requested that each relay vendor finish their tools so that they can have the capability of configuring an IEC61850 system independent of the relay manufacturers. A third test week was scheduled for March 2006.

In the third test week (March 2006), all manufacturers met again in the TVA “test lab” substation. Focus was now on the tools of the manufacturers and if they were able to support TVA in configuring their IEC61850 substation without any major support from the relay vendors and a need to have deep knowledge about the IEC61850 implementation details. The tools from ABB, GE Multilin and Siemens were found mature enough to fulfill the customer requirements. However, a new problem was discovered regarding different tools supporting different optional features of the IEC61850 standard. For example, the ABB IEDs need to know some hierarchical data like “voltage level”, “feeder name” in each IED. This data can be submitted to the IEC61850 system configurator via the SSD files (System Specification Description). This file format is optional in IEC61850 and doesn’t have to be implemented. The DIGSI system configurator in this case did not support this feature at this time. This made it necessary that after the SCD file was created by the DIGSI system configurator that the file was edited by an ABB tool to add this hierarchical data and then re-imported in the DIGSI system configurator.

At the end, TVA was able to develop a procedure that allowed them to configure and design the system independently without on-site support from the different relay manufacturers. This was demonstrated by TVA during the preparation for the May 2006 IEEE T&D show in Dallas, TX where the Bradley project configuration proved interoperability in the UCA International Users Group IEC61850 demonstration. TVA built the demonstration panels and configured the system that was placed on display at the show using the IEC61850 tools provided by each vendor.

Overall, the process involved a number of hurdles, but demonstrated that by having a strong and determined team of relay manufacturers and excellent group of TVA engineers, future IEC61850 project implementation can be successful and economical advantageous.

## 8. Client/Server Interface

The first several on-site lab sessions between the different vendors were used mainly for getting the relays configured, IEC61850 tools working properly and testing GOOSE communication. Next, came the point in time to check the relays integration to the clients (AREVA and Siemens). Client-Server interfaces have been tested between three graphical user interfaces (clients from two different suppliers) and different relays (servers from four different suppliers). See Figure 5 and 6 for network connections of IEDs and HMIs.

The client-server services that have been tested include connection establishment, data model retrieval, reports, measurements and control. The following are some observations & lessons learned during communication tests and client/server configuration.



- Data model retrieval: This communication service enables a client to discover a server's communication capabilities. It can be compared to a traditional web access where initially an electronic address is first entered and lead to the site discovery. This service has been proved to be extremely useful to simplify the client configuration.
- Buffered and unbuffered reports: This communication service is used to retrieve binary and analog data. Events (binary) are retrieved when there is a change of value or a change in the quality status. This was applied to GGIO (Generic I/O data) and XCBR (Circuit Breaker data) logical nodes. Analog data is sent periodically or when their change exceeds a dead-band limit. This service is subdivided into unbuffered and buffered reports. The benefit of buffered reports is to avoid the loss of data in case of a communication failure - the principle is to store the data normally sent into the server and send this archive once the communication is resumed. Whether to use buffered or unbuffered reports was a point of discussion between the different vendors for the communication from the IEDs (servers) to the substation control system (client). Unbuffered reports were tested with all devices. One relay vendor supported just buffered reports and another relay vendor can do both buffered and unbuffered reports. The relay vendor with the buffered report enabled his application to convert the reports to unbuffered.
- Report ID name: The Report ID needs to be unique inside each device. The Report ID assigned from one vendor had the same name for all devices and all the reports could not be imported into the client. The vendor created different reports for the client, but all of them had the same Report ID, thus the first report could only be imported into the client. The relay vendor made the necessary changes to the Report ID naming and all individual reports were successfully retrieved by the client.
- Length of the GOOSE ID: One vendor had the limitation for the length of the GOOSE ID. This vendor was not able to accept GOOSE ID's with more than 15 characters, thus the length of the GOOSE ID had to be limited within the project.
- Controls: Control was tested using the Select Before Operate (SBO) service to control the circuit breaker (XCBR).
- Controls without feedback: The SPCSO (Single Point Controllable Status Objects) are not contained in any Dataset. Datasets are the DataObject lists which are sent in the reports. Manual configuration of missed points (feedback of controls) for each relay vendor was necessary to allow the client to accept the controls.
- Measurements: We encountered the problem that the reports for measured values are built from data attributes. For example, an issue was encountered such that single phase values (DataAttributes) were individual items in an IED and the client wanted grouped three phase values (DataObjects). The client could not compute such reports. The reason for this is that expected datasets for client / server reports are built from DataObjects only. The reason behind this is that the value, quality and time from a unit that should not be split. Dividing up the information could lead to reports where only the value "mag" (magnitude) is reported, but not the quality and not the timestamp. Technically, there is also another problem with this report. According to IEC61850-7-3 the timestamp does not have a trigger option. Therefore, this value will never be reported (except in General Interrogation and integrity reports). Creating datasets from DataAttributes is acceptable for GOOSE communication where the entire dataset is always transmitted. For example, PhsAB is not a DataObject. However, PPV is a DataObject. In real world applications the other voltages, PhsBC and PhsCA, can also change their complex values. In GOOSE, all information is transmitted; it does not matter whether they are Data-Objects or Data-Attributes.
- Trigger options: The pictures below show the parameter for the trigger options associated to each report coming to the client from two different vendor IEDs/servers. While almost all vendors are using the Data Change, Quality Change, Data Update and General Interrogation options (see Figure 10), one vendor just sets the General Interrogation (see Figure 11). With only this parameter, the communication between the client and the relay will allow just a data transmission requested as General Interrogation. Using SISCO's AXS4MMS, an external tool as recommended by the vendor, it was possible to change the settings in the relay. Manually the setting has to be enabled to trigger option Data Change in SICAM PAS to match the relay (see Figure 12).

Part 6 of the IEC61850 standard defines the configuration process and the associated XML syntax known as SCL (Substation Configuration Language). The mechanism is to first get generic ICD (IED Configuration Description) files for each IED, then generate an SCD (Substation Configuration Description) file containing the definition of the dataset effectively used in the project, then import this SCD into each IED to synchronize the configuration of the different servers. While the standard places a lot of emphasis on the server side (i.e. relay), there is no restriction on the way the clients (i.e. OIP, SCADA) should be configured.

The client configuration mechanism was to dynamically "learn" the IED's capability at the connection establishment, i.e. logical node and datasets available. The benefit was to avoid the import of the SCD files, thus eliminate the coupling of the client configuration with the availability of this file (subject to a specific job, coordination of the various IEDs, interpretation, etc) and to accelerate the tests. This approach is certainly optimal for interoperability testing and should be complemented by some additional mechanisms in a real project. In this situation, all the IEDs might not be present during the database preparation and the overall database versioning must be handled carefully.



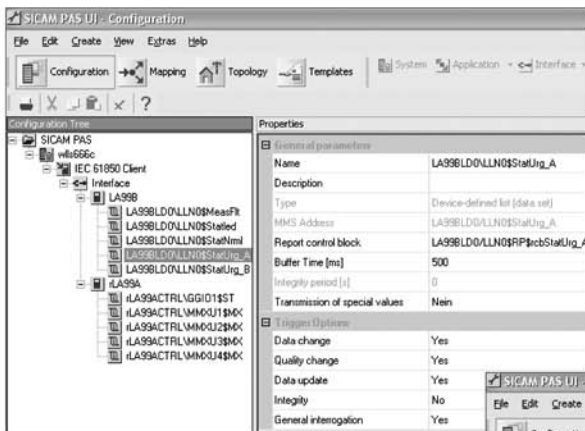

Figure 10.  
Trigger Options

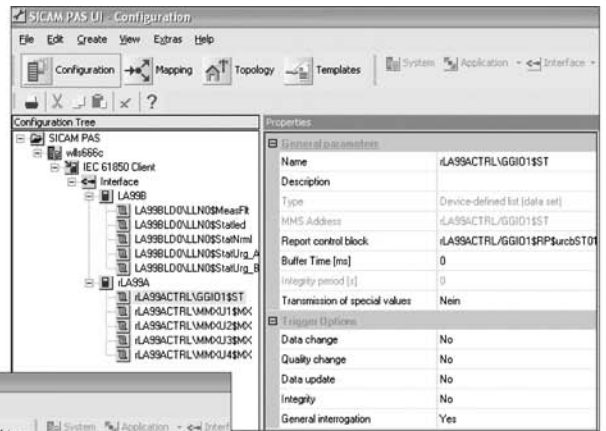

Figure 11.  
Trigger Options

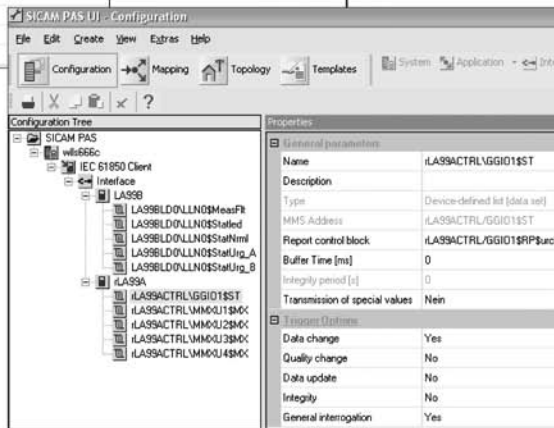

Figure 12.  
Trigger Options

The experience in this project has represented a big challenge not just for the customer but also for each one of the vendors participating. With the engagement of the customer, it has also been possible to get the vendors working as one team where everyone has given the best to achieve the project goals. An aspect that needs improvement is that until now, the work has focused 95% on the GOOSE configuration and communication forgetting the client/server implementation & expectations. We should not forget that in GOOSE, all information is transmitted, it does not matter whether they are Data-Objects or Data-Attributes but in a client-server relationship, the server sends only a small subset inside an information report for which a trigger condition is sent to the client. These trigger conditions like Quality change or Data change refer to DataObjects, which contain attributes like quality or magnitude. At the time of submission of this article, the last test for the integration of the ABB, GE and Siemens IEDs with the SCADA Gateway (Siemens SICAM PAS) has been successful. That means the final integration has been achieved and the interoperability is functional.

## 9. Lessons Learned Throughout Project

This project was a tremendous learning experience for the participating vendors and TVA. In addition to those described in the on-site lab workout and client/server interface sections, the following are some of the additional lessons learned throughout the project.

**VLAN issue with Ethernet switch** - The Virtual LAN (VLAN), an advanced layer 2 function defined in IEEE 802.1Q, high priority tagging of a message provides an efficient means for data exchange in applications using GOOSE on

IEC61850-8-1 station bus and IEC61850-9-2 process bus profiles. In the IEC61850 standard, a VLAN tag was defined as part of a valid GOOSE message. Some vendor's IED implementation required the VLAN tag in a received GOOSE messages to validate the information. The Ethernet switches used in the Bradley project initially did not pass the VLAN priority tag through the switch. This issue was identified early in the project and a firmware update was provided for the Ethernet switches.

**Logical device names** - Logical Device (LD) naming syntax is defined in IEC61850 part 7-2. The logical device names in this system were to be named according to the customer's standard practice for devices associated with breakers. The "99A" and "99B" breaker identification labels were preferred since this was TVA's standard for naming multifunction microprocessor based relays. The naming syntax restrictions defined in the IEC61850 standard does not allow these type of LD names (those starting with a number) due to constraints in MMS (Manufacturing Message Specification). The solution for this issue was to name the breaker IEDs (Logical Device names) "LA99A" and "LA99B" respectively.

**GOOSE ID naming** - GOOSE ID naming is an attribute that is contained in the GOOSE message. One IED vendor uses this GOOSE attribute to display status of received GOOSE messages. In the Bradley project's system engineering tool, the GOOSE ID was automatically assigned as a number although the standard is not restrictive to numbers and allows strings. The issue on utilization of IEC61850 data is that one vendor usage or extension of the data may not be possible with another vendor's implementation. The GOOSE ID strings in the SCD file were renamed using a separate tool capable of manually modification of GOOSE ID names.

**Status vs. quality order** - It was thought that it was necessary to specify which information in a GOOSE message was to be sent first, the data information or the quality information. It was discovered that different manufacturers and sometimes different relays from the same manufacturer did it differently, so there was a fear that the information may get misinterpreted. After a lot of discussions and phone calls, the team determined that the order of the information and quality data did not matter as long as it is declared in the ICD file. The receiving relay will get the information because it is defined via the SCD file and it knows how to process the information correctly.

**The effect of the quality state has on the status state** - Traditional/conventional hard wiring states are either on or off without an indication of signal quality. The IEC61850 standard does not provide rules for the interaction between quality and status bits. The question posed is should the loss of the quality state effect the state of the status value, thus a quality state of 0 results in a force of status state of 0 (even if the status is actually true or 1)? Or should a quality state of 0 result in staying at the last known status state (which is 1 in this example)?

**Both vendors meet standard, but do not interoperate** - Device (IED) conformance to the standard is accomplished by validating an IED at an accredited IEC61850 test facility in accordance to the IEC61850 part 10 and the UCA test procedures. It is important to note that the conformance testing does not validate conformity but only validates the IED testing has identified no "non-conformities". An IEC61850 device certificate is then issued by the accredited test facility providing the vendor a statement that no non-conformities were identified during the IED testing. The testing is limited to a single device in a test system and does not cover multi-device system level testing or interoperability in a multi-vendor system. To the point, the IEC61850 certificate does not guarantee that a certified device will interoperate with another device. Device level interoperability has been left to the vendors to validate device and client interoperability. In the Bradley project, all vendors had IEC61850 certified IEDs, but several issues as previously mentioned resulted from wrong interpretation or ambiguity in the IEC61850 standard. Other issues were also identified from wrong vendor implementations of the standard that were not identified during the certification process. Below are some examples of issues encountered during the Bradley project that impacted GOOSE interoperability between different vendor devices:

- **Supporting optional attributes in GOOSE** - One example of the interoperability issues encountered was that one vendor could include both mandatory and optional attributes in the IED using GOOSE messaging. Then in another vendor's IED (GOOSE receiver), this IED could only understand mandatory attributes and was not able to support the optional attributes; thus preventing interoperability. The resolution was to not use the vendor specific attributes in the GOOSE communication between these IEDs.
- **Adherence to name case sensitivity** - Another issue encountered was in the adherence lower and upper case sensitivity. One vendor was more liberal and did not strictly

adhere to the case sensitivity as defined in the standard. The other vendor's engineering tool was rejecting the names when the case was opposite to that as defined in the IEC61850 part 7. This was resolved by using a newer version of the SCL XML schema.

- **Quality in GOOSE versus no quality** - The support of data item quality flags in GOOSE datasets was a major obstacle in the beginning of the Bradley project. Different vendors provided different levels of support for quality flag data. In this case, one vendor required quality information in their application to confirm validity of the data for each value received via GOOSE. At the same time, another vendor was not able to send quality information in the GOOSE message. This resulted in the inability to exchange GOOSE message between IEDs and thus, a major interoperability issue. It was decided to use both status and quality within the Bradley project for consistency. Both quality and status are now available in each vendor's device and successful GOOSE interoperability between multiple vendors has been accomplished.
- **Length of names of GOOSE Control Blocks** - The length of GOOSE control block names supported in the different vendor IEDs was an issue. The Bradley project's system engineering tool automatically generates names for DataSets and GOOSE Control Blocks. The string length of these automatically generated names were too long for one vendor's IED. The GOOSE Control blocks in the SCD file were renamed using a separate tool capable of manually modifying the GOOSE control block names.
- **Substation section** - The substation section of SCL file contains information about the substation layout, logical node references and device configuration and association information. One vendor's IED tool required this substation section along with the Logical Node references to be imported from SCD file generated by the system engineering tool. The system engineering tool was not able to produce the needed information so manual manipulation of the SCD files was required to complete the IED engineering. The resolution was manual configuration of the SCD file adding the necessary information.

**What vendors have to improve to make it easier?** - Better preparation of the product and system technology is needed. IEC61850 is a very comprehensive and complex standard that has the potential to revolutionize substation automation systems if the necessary tools and product functionality is available. The vendors involved in this project needed to collaborate to assure that the substation automation system functionality and interoperability capabilities were validated prior to the execution of the customer engineering and system build up.

Some limitations in vendor implementations made some necessary design choices at the beginning of the project. The concept of using only GGIOs for all GOOSE communication was the right approach to start some testing, but for the real system a solution using correct Logical Nodes should be considered.

For example, circuit breaker position using GGIOs are sent as separate Boolean signals for open and closed breaker commands. In the standard, there are Logical Nodes and Data Objects defined for this purpose.

Another area that has not been explored prior to this project is the engineering process. It is very important for the necessary information exchange between system engineering and IED tools to really take advantage of the many benefits developed in the IEC61850 standard.

**What could have been done differently?** - Clearly, the lessons learned in the multi-vendor TVA Bradley IEC61850 substation project have been extremely valuable for the entire industry pushing for this new standard. From the industry side, the availability of an IEC61850 certified device only validates an IED to a small portion of the standard and does not address complete device level interoperability. The extent of the Bradley project provides complete functionality with a goal to move into the digital substation.

We can state that the Bradley project has explored all benefits made possible through the new standard that prior to this project has not been done in a multi-vendor environment. Most of executed IEC61850 projects have been turnkey homogenous vendor solutions where interoperability between one vendor's products is much easier. In the other projects where multi-vendor projects have been executed, the foreign device has typically been a main 2 or backup protection terminal where the system functionality only required limited exposure of the IED functionality via the IEC61850 system.

On the other hand, industry expositions demonstrating multi-vendor IEC61850 interoperability have set expectations that the complete IEC61850 benefits are readily available. This is not the case since these demonstrations focus on simplistic applications and minimal functionality to prove vendor A can interoperate with vendor B.

What could have been done in this project is to set up an interoperability project to validate product and system functionality before starting the Bradley project. In this case, the project was conducting the interoperability validation. System engineering is the critical step in the Bradley project where an open discussion regarding system engineering tool to know the limitation in the integration of other vendor's IEDs. The system engineering process is one area that multi-vendor exchange of IED and engineering data needs improvements. Today, a vendor's system engineering tool works perfectly with their own devices but creates limitation when exposed to other vendor's devices.

What needs to be done in the industry is a higher level of interoperability functionality and standard test cases that can assure a minimum level of interoperability. Today, the actual substation automation system projects are performing this function but at a significant expense when untested IEDs are used for this first time in a system. The result is unnecessary project delays and cost increases. Here the recommendation is that the UCA International Users Group on behalf of the utilities set up performance and functionality criteria for levels of interoperability. Device level conformance certification only validates a fraction of the overall substation automation capability.

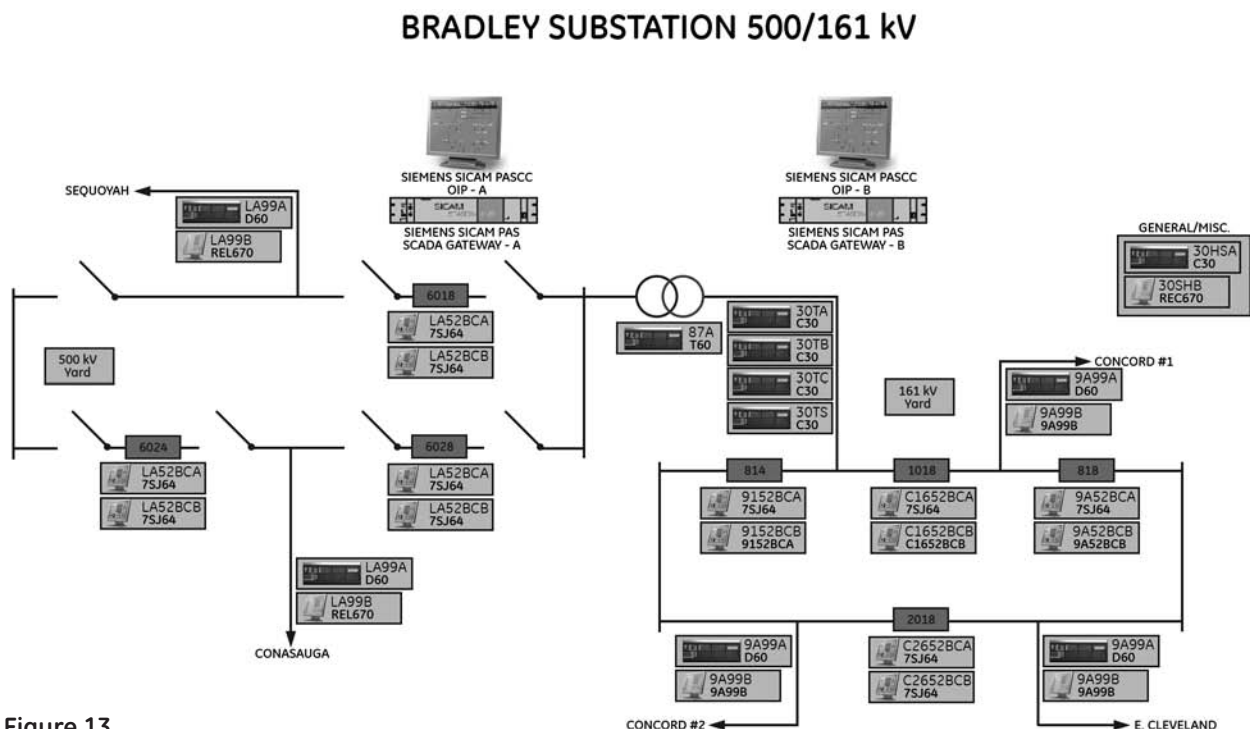

**Figure 13.**  
Final configuration of TVA Bradley substation

## 10. Conclusions

A strong and determined team of relay manufacturers and an excellent group of TVA engineers made this Bradley project a success in utilizing the IEC61850 standard as much as practically possible. Figure 13 shows the final design being deployed for the TVA Bradley Substation.

The experience in this project created a big challenge not just for the customer but also for each one of the vendors participating. With the engagement of the customer, it has also been possible to get the vendors working as a collective team where everyone has given their best effort to achieve the project goals. It is in the best interest to the industry to evolve the technology based on IEC61850 since the standard has been developed through a vendor-utility collaborative effort.

The lessons learned in the device interoperability and IEC61850 engineering processes from the IEDs and software tools used by the vendors and TVA were very valuable. Successful IEC61850 GOOSE interoperability has been implemented between different relay manufacturers on this project. In addition, successful integration of the ABB, GE and Siemens IEDs with the SCADA Gateway (Siemens SICAM PAS) has been implemented. These lessons learned have resulted in the vendor's maturity in IEC61850 technology allowing future IEC61850 project implementations to be configured by the customer easily and without on-site vendor support.

Integrated protection, control and monitoring projects, such as the Bradley Substation, need to focus on all areas including client/server interface, not just the GOOSE configuration and communication.

The industry needs to develop a higher level of interoperable functionality and standard test cases that can assure a minimum level of interoperability. The UCA International Users Group on behalf of the utilities needs to set up performance and functionality criteria defining various levels of interoperability. Device level conformance certification only validates a fraction of the overall substation automation capability.

The industry should consider Ethernet Switches as a "protective device" when it comes to implementations of critical protection schemes using IEC61850 standard and whether they are configured and maintained by protection/test engineers or the IT department.

To look back in time, the vision established in the mid-1990s by the EPRI and AEP LAN Initiative is now realizable. Projects like the TVA Bradley 500kV project is truly the first US based multi-vendor IEC61850 substation automation system. This project has set the industry benchmark on complexity and functionality achieved through the utilization of products based on the new IEC61850 standard. This project's experiences will be valuable to many other utilities as they also proceed to adopt the new products and systems creating the next generation of digital substations.