

# GE Grid Solutions

## Model GFM

### Ground Fault Current Detection Systems

#### Model GFM Relay (For Use with GFM sensors only)

##### Adjustable Operating Range

Trip currents from 2.0 to 65 Amperes  
Time delay from instantaneous to 36 cycles

##### Input Power

Self powered.

##### Frequency

50/60 Hz.

##### Ambient Temperature Range

-30 °C to +60 °C.

##### Operation

Positive condition indication  
Normal (Reset) - Green ("ON")  
Tripped - Red ("OFF")  
Manual Reset



Model GFM - 252  
& Model 262



Model GFM - 353, 363, 453,  
and 463

The class 1 model GFM Ground Fault protection systems are designed to minimize damage or loss to equipment caused by destructive arcing ground faults. This GFM systems is designed for all polyphase applications and is ideally suited for motor control, motor control centers, and medium voltage starters. System can be wye or delta, ground or resistance grounded. When the ground fault current exceeds a pre-selected condition (current and time setting) the relay trips.

The relay contacts can be connected in the control circuit of a motor starter, to the shunt trip of a circuit breaker or similar disconnecting or alarm devices. The system has an inverse time characteristic to prevent nuisance tripping. The relay tripping current value is field adjustable over the trip current range of the sensor. The adjustable trip time delay relay is field selectable up to 36 cycles.

#### REGULATORY AGENCY APPROVALS



110395



LR80793

#### How to Order Relays

GFM-	X	X	X	Part Number
Case Style	2			P.B. Style-Door Mount
	3			Panel Mount
	4			Door Mount
Time Delay		5		Instantaneous
		6		Adjustable Time Delay up to 36 Cycles
Output Contacts	2			10 A Form C Contacts (Case Style 2 only)
	3			10 A Form C Contacts plus 30A N.O. Contact (on case Styles 3 & 4 only)

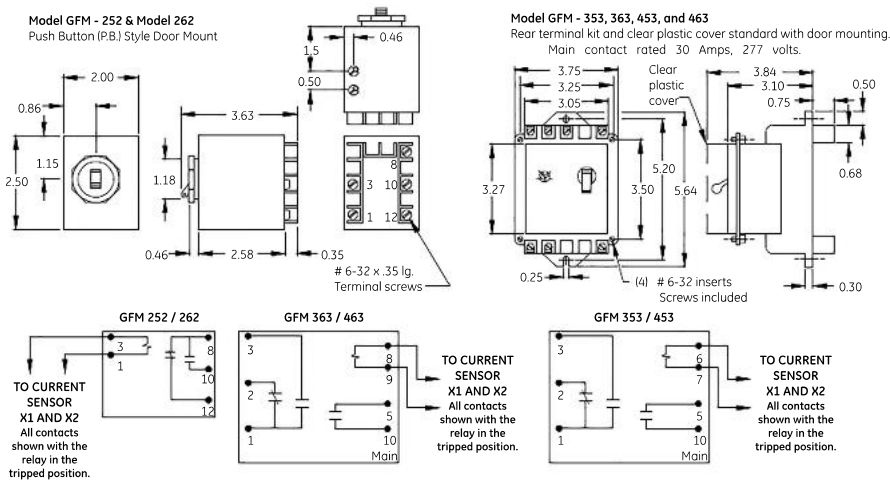

### Model GFM Sensors (For Use with GFM relays only)

**2.0 to 65 Amp Trip Currents**  
**Toroidal, Rectangular, & 3 Hole Sensors**

**Frequency**  
 50/60 Hz

**Insulation Level**  
 600 Volt, 10 kV BIL

**Terminals**  
 Terminals are brass studs No. 8-32.

Type GFM Ground Fault Current Sensors are available in three different case styles and a variety of sizes and trip current ranges to match the GFM Relay. The physical size of the sensor window should be carefully determined by the physical size and configuration of the power conductors. The Ground Fault Sensor will respond only to ground faults which occur between the position of the sensor and the load.

**CAUTION:**

*Proper safety precautions must be followed during installation by a trained electrician. It is recommended that the incoming power be de-energized before installation. The sensor must have its secondary terminals short circuited or the relay connected before energizing the primary circuit.*

### GFM Toroidal Sensors



Toroidal Sensors

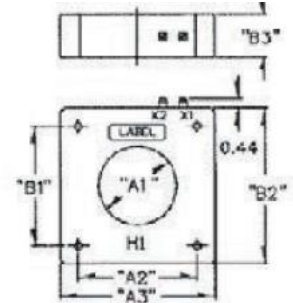

Trip Current	Model Number	"A1"	"A2"	"A3"	"B1"	"B2"	"B3"
2.0 to 8.5	** GFM 094	0.94	N/A	2.67	N/A	2.75	2.38
2.7 to 14	** GFM 125	1.25	N/A	2.67	N/A	2.75	2.38
4.5 to 18	** GFM 156	1.56	N/A	3.53	N/A	3.77	2.15
3.5 to 14.5	GFM 200	2.00	3.19	4.00	N/A	4.00	1.75
3.5 to 11	GFM 250	2.50	3.75	4.63	N/A	5.10	3.00
4 to 12	GFM 375	3.75	4.75	5.96	4.75	6.31	3.00
*	GFM 375D	3.75	4.75	5.96	4.75	6.31	3.00
5 to 18	GFM 425	4.25	5.44	6.73	5.43	6.73	1.28
4 to 12	GFM 462	4.62	5.75	7.00	5.75	7.12	4.00
4 to 12	GFM 813	8.13	8.50	11.10	8.50	11.47	3.00

\*Dual trip current ranges 3.5 to 11 and 10 to 36  
 \*\* Mounting bracket kits are available for all toroidal sensors except the Model GFM 094, GFM 125, and GFM 156, which have molded mounting feet

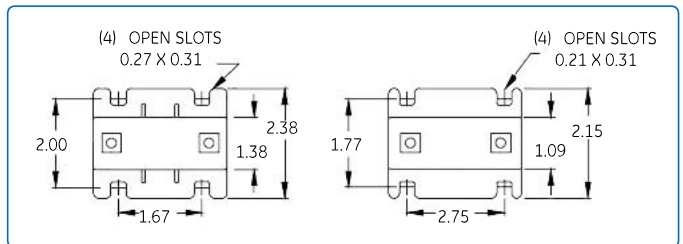

### GFM Sensor

Model Number	Bracket Kit
GFM 200	0221B01976
GFM 250	0221B00541
GFM 375	0221B00259
GFM 375D	0221B00259
GFM 425	0221B00187
GFM 462	0221B01525
GFM 813	0221B00259

### GFM Rectangular Sensors



Rectangular Sensors

Trip Current	Model Number	"A1"	"A2"	"A3"	"B1"	"B2"	"B3"
6 to 30	GFM 041 X 071	4.1	6.4	7.3	7.1	10.0	10.9
15 to 65	* GFM 080 X 117SC	8.0	9.5	11.1	11.7	14.5	15.4
9 to 39	GFM 080 X 141	8.0	9.5	11.1	14.1	17.0	17.9

\* Model GFM 080 X 117SC is split core (take-apart style) for assembly to existing electrical installations without the need for dismantling the primary bus or cables.

### GFM 3-Hole Sensors



3-Hole Sensors (1-Core)

Trip Current	Model Number	"A1"	"A2"	"A3"	"B1"	"B2"	"B3"
4.5 to 16	GFM 3P205 X 050	*	7.60	8.50	3.70	2.00	2.75
5 to 20	**GFM 3P208	2.08	8.24	9.00	3.94	2.00	2.75
7 to 25	GFM 3P212	2.12	11.72	12.80	4.87	2.63	4.00

\* The Model GFM 3P205 X 050 has a rectangle window 2.05" X 0.50".

\*\* UL Listed Only - No CSA Approval

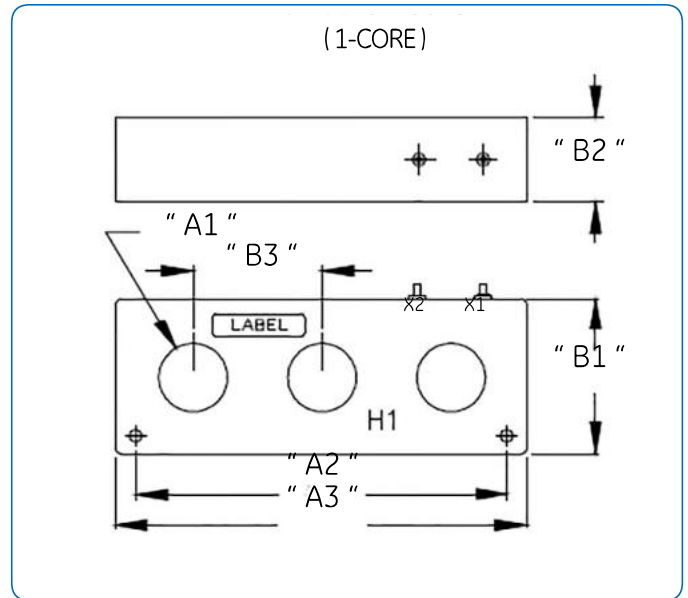
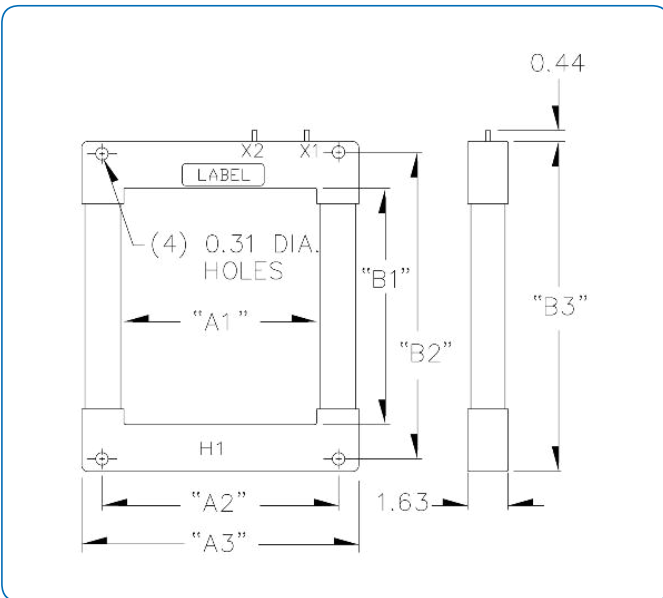

## Pick-Up and Time Delay Characteristics

GE GFM sensors are assigned a current range to indicate a pick-up current level.

The GFM relay has a range select from "A" to "D". "A" is the lowest current magnitude pick-up and "D" is the highest. The pick up level is dependent on the energy in a ground fault wave shape; therefore tripping initiation depends on the wave shape and regularity of the fault current.

In general, the relay will pick up before 150 % of the low end of the sensor current range on the "A" setting with a sinusoidal signal, and will pick up before 150 % of the high end of the sensor range on the "D" setting. The relay is adjustable continuously from "A" to "D" so that identical sensors can be coordinated.

GFM ground fault system has inverse time current trip characteristics. As the fault current increases, the trip time delay gets shorter. The GFM-252, GFM-353, GFM-453 relays do not have adjustable trip time delay, while the GFM-262, GFM-363, GFM-463 relays have adjustable trip time delay.

Trip time on Models with fixed time delay, may exceed a one second delay.

Trip time on Models with fixed time delay, may exceed a one second delay at the pick up threshold. Trip time on Models with adjustable time delay, may exceed a one second delay at the pick up threshold, however the inverse time curve can be modified to vary trip time at multiples of over current with an ordinal "1" to "4" is scale where "1" is faster and "4" is slower.

The pick up time delay on the fixed time delay relays can be as fast as 0.02 seconds on the "A" setting, and 0.1 seconds on the "D" setting at high fault currents.

For the adjustable time delay relays, a time delay of "1" in the "A" scale can produce a time delay of under 0.15 seconds at a 600% sinusoidal fault. A time delay setting of "4" will result in a time delay approximately 0.2 seconds slower than the "1" setting. Time delay will be greater for smaller fault current.

Similarly, a time delay setting of "1" in the "D" scale can produce a time delay of under 0.4 seconds at a 600% sinusoidal fault. A time delay setting of "4" will result in a time delay approximately 0.2 seconds slower than the "1" setting. Time delay will be greater for smaller fault current.

## Fixed Delay Types - GFM Test Procedure

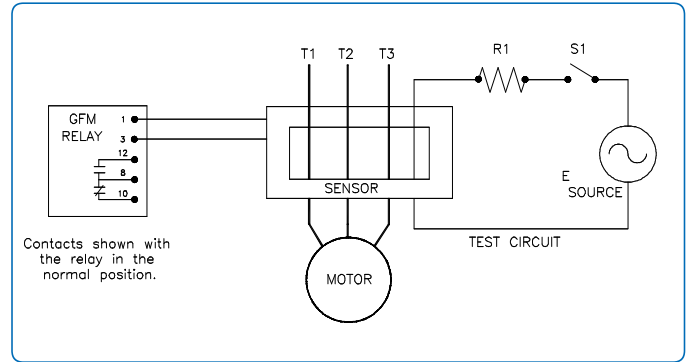

A Simulated fault current can be applied by the above test circuit. An appropriate value of R1 should be selected to apply a minimum of 1.5 times maximum trip rating of the sensor.

1. Assure that the GFM relay is in "NORMAL" (reset) position.
2. Close switch S1, and check for reset for response. Relay handle will move to the tripped position.
3. Open S1, reset the relay and remove the test circuit from the system. System is now back to normal.

*This PROCEDURE should be performed by Qualified Personnel only.*



### GEGridSolutions.com

ITI-Model-GFM-Spec-EN-2020-09-Grid-AIS-1134. © Copyright 2020. General Electric Company and Instrument Transformers LLC reserve the right to change specifications of described products at any time without notice and without obligation to notify any person of such changes.

#### Worldwide Contact Center

Web: [www.GEGridSolutions.com/contact](http://www.GEGridSolutions.com/contact)

Phone: +44 (0) 1785 250 070

USA and Canada: +1 (0) 800 547 8629

Europe, Middle East and Africa: +34 (0) 94 485 88 00