



GE VERNOVA

P50 Agile

P652

Technical Manual
Transformer Protection Relay

Hardware version: A
Software version: 01
Publication reference: P652/EN M/C



Conformity

This product complies with the directive of the Council of the European Communities relating to electromagnetic compatibility (EMC directive 2004/108/EC) and product safety (Low-voltage directive 2006/95/EC). This conformity is the result of a test conducted in accordance with the product standard EN 60255- 26 for the EMC directive, and with the product standard EN 60255-27 for the low voltage directive. The IED is designed in accordance with the international standards of the IEC 60255 series.

INTRODUCTION

CHAPTER 1

1 CHAPTER OVERVIEW

This chapter consists of the following sections:

- 1 Chapter Overview**
- 2 Introduction**
 - 2.1 Features
 - 2.1.1 Protection & Control
 - 2.1.2 Measurement, Recording & Post fault analysis
 - 2.1.3 Front panel interface
 - 2.1.4 Communications
 - 2.2 Functional overview
 - 2.3 Ordering information

2 INTRODUCTION

2.1 Features

The P652 is a dedicated differential protection relay intended for protection of two winding transformer installed in MV/LV industrial installations, public distribution networks and substations. The P652 is an economical choice, designed for deployment in volume, for system voltages upto 66/69 kV.

The P652's main protection is high-speed differential using a triple slope characteristic which incorporates high-set differential elements. This operates in combination with transformer inrush restraint, and through fault stabilisation. Amplitude and vector group matching is done just by entering the nominal values of transformer and associated CTs. The relay can compensate for all standard transformer vector connections and for different CT ratios across the transformer without the need for secondary interposing CTs. Restricted earth fault (REF) protection is provided per winding, delivering fast fault clearance even in the event of internal faults with moderate fault current flowing. REF protection may be applied in either high or low impedance modes.

The extensive set of protective functions also includes thermal overload protection, backup overcurrent/earth fault protection (HV and LV side) for uncleared external faults, negative sequence overcurrent (HV and LV), Trip circuit supervision and breaker failure detection (HV and LV breakers). Timed and instantaneous phase and earth fault protection are provided with up to 3 independent stages. IEC and IEEE curve types are provided for IDMT functions. Multiple setting groups are included. The hardware capability is broadened by a universal auxiliary power supply range to permit standardisation in procurement and inventories.

The user may assign any of the logical/physical statuses to binary inputs, binary outputs and programmable LEDs. This provides flexibility to program the relay as per the application requirements. All the output contacts are changeover type for ease of implementing the desired wiring schematic.

The P652 relay offers essential supervision like measurement, monitoring and recording functions. Communication protocols are available for transmitting relay data to a supervisory control system via communication networks. The user-friendly operator interface allows easy reading of measured values and simple configuration of the relay. The setting software allows for user easy configuration and access to all the stored information for monitoring, maintenance and troubleshooting purposes. The P652 relay is housed in a robust metal case suitable for panel mounting.

2.1.1 Protection & Control

- Biased differential current protection with Harmonic restraint
- Biased & Unbiased differential high-set
- Integral current amplitude and vector group compensation.
- Inrush blocking based on 2nd Harmonic
- 5th Harmonic Blocking against transient overfluxing condition
- Restricted earth fault (REF – high and low impedance mode selection)
- Through fault monitoring
- Thermal overload protection
- Timed and instantaneous phase and earth fault protection (3 independent stages)
- Wide range of IEC/IEEE curves
- Negative sequence overcurrent
- Circuit breaker fail
- Trip circuit supervision

- 6 Digital inputs
- 6 Digital output (changeover type, form-C)
- Latching of output contacts
- Universal auxiliary power supply range
- 2 Setting groups
- Password protection
- Self-supervision & internal diagnostics
- Watchdog function
- Commissioning/maintenance facilities

2.1.2 Measurement, recording & post fault analysis

- Metering of phase currents for each winding
- Metering of neutral currents for each winding
- Measurement of thermal state
- Positive, negative and zero sequence currents for each winding
- Metering of bias currents for each phase
- Metering of differential currents for each phase
- Metering of REF bias current for each winding
- Metering of REF differential current for each winding
- Metering of true RMS phase currents for each winding
- Breaker operation counter
- Breaker trip counter
- Breaker operating time
- Up to 512 time tagged event records
- Up to 5 Fault records
- Up to 5 disturbance records

2.1.3 Front panel interface

- 8 LEDs for status indication
- Backlit LCD display (16 x 2)
- 8 navigation keys for setting and interrogation

2.1.4 Communications

- Front USB port for real-time data viewing, device setting, and upload/download.
- Rear EIA (RS) 485 port for SCADA communication
- Multiple protocols - Modbus/ IEC60870-5-103 or DNP3.0 (ordering option)

2.2 Functional overview

ANSI	FUNCTION	P652
87	Transformer Differential (2 winding)	•
64	Restricted earthfault (low or high impedance)- HV and LV	•
50	Definite time overcurrent	•
50N	Neutral/Earth definite time overcurrent	•
51	IDMT overcurrent	•
51N	Neutral/Earth IDMT overcurrent	•
68	Inrush Blocking	•
49	Thermal Overload	•
46	Negative sequence overcurrent	•
50BF	Circuit breaker fail	•
86	Latching of output contacts (Lockout)	•
Control Functions		
74	Trip circuit supervision	•
	Watchdog function	•
	Self monitoring & diagnostics	•
	Test/Commissioning facilities	•
HMI		
	Back-Lit LCD display	•
	8 x Touch Keys	•
	8 x status LEDs	•
Communication		
	USB port	•
	Modbus/IEC 60870-5-103 (RS485) (or) DNP3.0	•
Binary Input/Output		
	Binary Input	6
	Binary Output	6 (c/o)
Analogue Input		
	Phase current input	6 CTs
	Earth current input	2 CTs
General		
	Setting Groups	2
	Self diagnostics	•
	Measurements	•
	Event records	•
	Fault records	•
	Disturbance records	•
	Configurable BI/BO/LEDs	•

ANSI	FUNCTION	P652
	Hardware	
	Auxiliary supply	24-230 V AC/DC
	Climatic conditions	Operating : - 25° C to + 55 °C Storage : - 25° C to + 70 °C
	Housing	Front IP 52 Rear IP 20

2.3 Ordering information

Variants	Order Number														
	1 - 4	5	6	7	8	9	10	11	12-13	14	15				
Model Type Basic Transformer Protection Relay (2 winding)	P652														
Auxiliary Voltage 24 – 230 V DC/AC	Binary Input Threshold Voltage 18V DC / 16V AC														
24 – 230 V DC/AC	35V DC / 33V AC														
24 – 230 V DC/AC	77V DC / 75V AC														
24 – 230 V DC/AC	154V DC / 152V AC														
Current Transformer															
<u>Phase CT</u>	<u>Neutral CT</u>														
HV / LV= 1A	1A / 5A														
HV / LV= 5A	1A / 5A														
HV=1A, LV= 5A	1A / 5A														
HV=5A, LV= 1A	1A / 5A														
Hardware Options EIA RS485 only	1														
I/O Options Standard (6 logic inputs + 6 relay outputs)	A														
Communication Protocol Modbus / IEC 60870-5-103 DNP3.0	1 2														
Case Non drawout	A														
Language English	0														
Software Reference Initial release (v1.xx)	01														
Customisation / Regionalisation Default Customer specific	0 A														
Hardware Design Suffix Initial release	A														

Figure 1: Ordering information

SAFETY INFORMATION

CHAPTER 2

1 HEALTH AND SAFETY

Personnel associated with the equipment must be familiar with the contents of this Safety Information.

When electrical equipment is in operation, dangerous voltages are present in certain parts of the equipment. Improper use of the equipment and failure to observe warning notices will endanger personnel.

Only qualified personnel may work on or operate the equipment. Qualified personnel are individuals who are:

- familiar with the installation, commissioning, and operation of the equipment and the system to which it is being connected.
- familiar with accepted safety engineering practises and are authorised to energise and de-energise equipment in the correct manner.
- trained in the care and use of safety apparatus in accordance with safety engineering practises
- trained in emergency procedures (first aid).

The documentation provides instructions for installing, commissioning and operating the equipment. It cannot, however cover all conceivable circumstances. In the event of questions or problems, do not take any action without proper authorisation. Please contact your local sales office and request the necessary information.

2 SYMBOLS

Throughout this manual you will come across the following symbols. You will also see these symbols on parts of the equipment.



Caution:
Refer to equipment documentation. Failure to do so could result in damage to the equipment



Warning:
Risk of electric shock



Earth terminal. *Note: This symbol may also be used for a protective conductor (earth) terminal if that terminal is part of a terminal block or sub-assembly.*



Protective conductor (earth) terminal



Instructions on disposal requirements

Note:

The term 'Earth' used in this manual is the direct equivalent of the North American term 'Ground'.

3 INSTALLATION, COMMISSIONING AND SERVICING

3.1 LIFTING HAZARDS

Many injuries are caused by:

- Lifting heavy objects
- Lifting things incorrectly
- Pushing or pulling heavy objects
- Using the same muscles repetitively

Plan carefully, identify any possible hazards and determine how best to move the product. Look at other ways of moving the load to avoid manual handling. Use the correct lifting techniques and Personal Protective Equipment (PPE) to reduce the risk of injury.

3.2 ELECTRICAL HAZARDS



Caution:
All personnel involved in installing, commissioning, or servicing this equipment must be familiar with the correct working procedures.



Caution:
Consult the equipment documentation before installing, commissioning, or servicing the equipment.



Caution:
Always use the equipment as specified. Failure to do so will jeopardise the protection provided by the equipment.



Warning:
Removal of equipment panels or covers may expose hazardous live parts. Do not touch until the electrical power is removed. Take care when there is unlocked access to the rear of the equipment.



Warning:
Isolate the equipment before working on the terminal strips.



Warning:
Use a suitable protective barrier for areas with restricted space, where there is a risk of electric shock due to exposed terminals.



Caution:
Disconnect power before disassembling. Disassembly of the equipment may expose sensitive electronic circuitry. Take suitable precautions against electrostatic voltage discharge (ESD) to avoid damage to the equipment.



Caution:
NEVER look into optical fibres or optical output connections. Always use optical power meters to determine operation or signal level.



Caution:
 Testing may leave capacitors charged to dangerous voltage levels. Discharge capacitors by reducing test voltages to zero before disconnecting test leads.



Caution:
 Operate the equipment within the specified electrical and environmental limits.



Caution:
 Before cleaning the equipment, ensure that no connections are energised. Use a lint free cloth dampened with clean water.

Note:
 Contact fingers of test plugs are normally protected by petroleum jelly, which should not be removed.

3.3 UL/CSA/CUL REQUIREMENTS

The information in this section is applicable only to equipment carrying UL/CSA/CUL markings.



Caution:
 Equipment intended for rack or panel mounting is for use on a flat surface of a Type 1 enclosure, as defined by Underwriters Laboratories (UL).



Caution:
 To maintain compliance with UL and CSA/CUL, install the equipment using UL/CSA-recognised parts for: cables, protective fuses, fuse holders and circuit breakers, insulation crimp terminals, and replacement internal batteries.

3.4 FUSING REQUIREMENTS



Caution:
 Where UL/CSA listing of the equipment is required for external fuse protection, a UL or CSA Listed fuse must be used for the auxiliary supply. The listed protective fuse type is: Class J time delay fuse, with a maximum current rating of 15 A and a minimum DC rating of 250 V dc (for example type AJT15).



Caution:
Where UL/CSA listing of the equipment is not required, a high rupture capacity (HRC) fuse type with a maximum current rating of 16 Amps and a minimum dc rating of 250 V dc may be used for the auxiliary supply (for example Red Spot type NIT or TIA).
For P50 models, use a 1A maximum T-type fuse.
For P60 models, use a 4A maximum T-type fuse.



Caution:
Digital input circuits should be protected by a high rupture capacity NIT or TIA fuse with maximum rating of 16 A. for safety reasons, current transformer circuits must never be fused. Other circuits should be appropriately fused to protect the wire used.



Caution:
CTs must NOT be fused since open circuiting them may produce lethal hazardous voltages

3.5 EQUIPMENT CONNECTIONS



Warning:
Terminals exposed during installation, commissioning and maintenance may present a hazardous voltage unless the equipment is electrically isolated.



Caution:
Tighten M4 clamping screws of heavy duty terminal block connectors to a nominal torque of 1.3 Nm.
Tighten captive screws of terminal blocks to 0.5 Nm minimum and 0.6 Nm maximum.



Caution:
Always use insulated crimp terminations for voltage and current connections.



Caution:
Always use the correct crimp terminal and tool according to the wire size.



Caution:
Watchdog (self-monitoring) contacts are provided to indicate the health of the device on some products. We strongly recommend that you hard wire these contacts into the substation's automation system, for alarm purposes.

3.6 PROTECTION CLASS 1 EQUIPMENT REQUIREMENTS



Caution:
Earth the equipment with the supplied PCT (Protective Conductor Terminal).



Caution:
Do not remove the PCT.



Caution:
The PCT is sometimes used to terminate cable screens. Always check the PCT's integrity after adding or removing such earth connections.



Caution:
Use a locknut or similar mechanism to ensure the integrity of stud-connected PCTs.



Caution:
The recommended minimum PCT wire size is 2.5 mm² for countries whose mains supply is 230 V (e.g. Europe) and 3.3 mm² for countries whose mains supply is 110 V (e.g. North America). This may be superseded by local or country wiring regulations.
For P60 products, the recommended minimum PCT wire size is 6 mm². See product documentation for details.



Caution:
The PCT connection must have low-inductance and be as short as possible.



Caution:
All connections to the equipment must have a defined potential. Connections that are pre-wired, but not used, should be earthed, or connected to a common grouped potential.

3.7 PRE-ENERGISATION CHECKLIST



Caution:
Check voltage rating/polarity (rating label/equipment documentation).



Caution:
Check CT circuit rating (rating label) and integrity of connections.



Caution:
Check protective fuse or miniature circuit breaker (MCB) rating.



Caution:
Check integrity of the PCT connection.



Caution:
Check voltage and current rating of external wiring, ensuring it is appropriate for the application.

3.8 PERIPHERAL CIRCUITRY



Warning:
Do not open the secondary circuit of a live CT since the high voltage produced may be lethal to personnel and could damage insulation. Short the secondary of the line CT before opening any connections to it.

Note:

For most GE Vernova equipment with ring-terminal connections, the threaded terminal block for current transformer termination is automatically shorted if the module is removed. Therefore, external shorting of the CTs may not be required. Check the equipment documentation and wiring diagrams first to see if this applies.



Caution:
Where external components such as resistors or voltage dependent resistors (VDRs) are used, these may present a risk of electric shock or burns if touched.



Warning:
Take extreme care when using external test blocks and test plugs such as the MMLG, MMLB and P990, as hazardous voltages may be exposed. Ensure that CT shorting links are in place before removing test plugs, to avoid potentially lethal voltages.

3.9 UPGRADING/SERVICING



Warning:
Do not insert or withdraw modules, PCBs or expansion boards from the equipment while energised, as this may result in damage to the equipment. Hazardous live voltages would also be exposed, endangering personnel.



Caution:
Internal modules and assemblies can be heavy and may have sharp edges. Take care when inserting or removing modules into or out of the IED.

4 DECOMMISSIONING AND DISPOSAL



Caution:

Before decommissioning, completely isolate the equipment power supplies (both poles of any dc supply). The auxiliary supply input may have capacitors in parallel, which may still be charged. To avoid electric shock, discharge the capacitors using the external terminals before decommissioning.



Caution:

Avoid incineration or disposal to water courses. Dispose of the equipment in a safe, responsible and environmentally friendly manner, and if applicable, in accordance with country-specific regulations.

5 STANDARDS COMPLIANCE

Compliance with the European Commission Directive on EMC and LVD is demonstrated using a Technical File.



5.1 EMC COMPLIANCE: 2004/108/EC

Compliance with EN60255-26:2009 was used to establish conformity.

5.2 PRODUCT SAFETY: 2006/95/EC

Compliance with EN60255-27:2005 was used to establish conformity.

Protective Class

IEC 60255-27: 2005 Class 1 (unless otherwise specified in equipment documentation). This equipment requires a protective conductor (earth) to ensure user safety.

Installation category

IEC 60255-27: 2005 Overvoltage Category 3. Equipment in this category is qualification tested at 5kV peak, 1.2/50 mS, 500 Ohms, 0.5 J, between all supply circuits and earth and also between independent circuits.

Environment

IEC 60255-27: 2005, IEC 60255-26:2009. The equipment is intended for indoor use only. If it is required for use in an outdoor environment, it must be mounted in a specific cabinet or housing which will enable it to meet the requirements of IEC 60529 with the classification of degree of protection IP54.

5.3 R&TTE COMPLIANCE

Radio and Telecommunications Terminal Equipment (R&TTE) directive 99/5/EC.

Conformity is demonstrated by compliance to both the EMC directive and the Low Voltage directive, to zero volts.

5.4 UL/CUL COMPLIANCE

If marked with this logo, the product is compliant with the requirements of the Canadian and USA Underwriters Laboratories.

The relevant UL file number and ID is shown on the equipment.



5.5 ATEX COMPLIANCE

If marked with the logo, the equipment is compliant with article 192 of European directive 94/9/EC. It is approved for operation outside an ATEX hazardous area. It is however approved for connection to Increased Safety, "Ex e", motors with rated ATEX protection, equipment category 2, to ensure their safe operation in gas zones 1 and 2 hazardous areas.



Equipment with this marking is not itself suitable for operation within a potentially explosive atmosphere.

Compliance demonstrated by Notified Body Type Examination Certificate.



II (2) G

ATEX Potentially Explosive Atmospheres directive 94/9/EC for equipment.

HARDWARE DESIGN

CHAPTER 3

1 CHAPTER OVERVIEW

This chapter consists of the following sections:

- 1 **Chapter Overview**
- 2 **Hardware Design**
 - 2.1 Overview of hardware design
 - 2.2 Microcontroller with DSP module
 - 2.2.1 Microcontroller module (Processor board) features
 - 2.3 Microcontroller and analog measurement
 - 2.4 Digital input /output module
 - 2.5 Power supply module
 - 2.6 Communication module
 - 2.7 Human machine interface module

2 HARDWARE DESIGN

The P652 hardware comprises of following main components:

- Housing, consisting of a front panel and connections at the rear
- Microcontroller module
- Analogue input module
- Digital input module
- Digital output module
- Communication module
- Power supply unit
- Human machine Interface (HMI) module

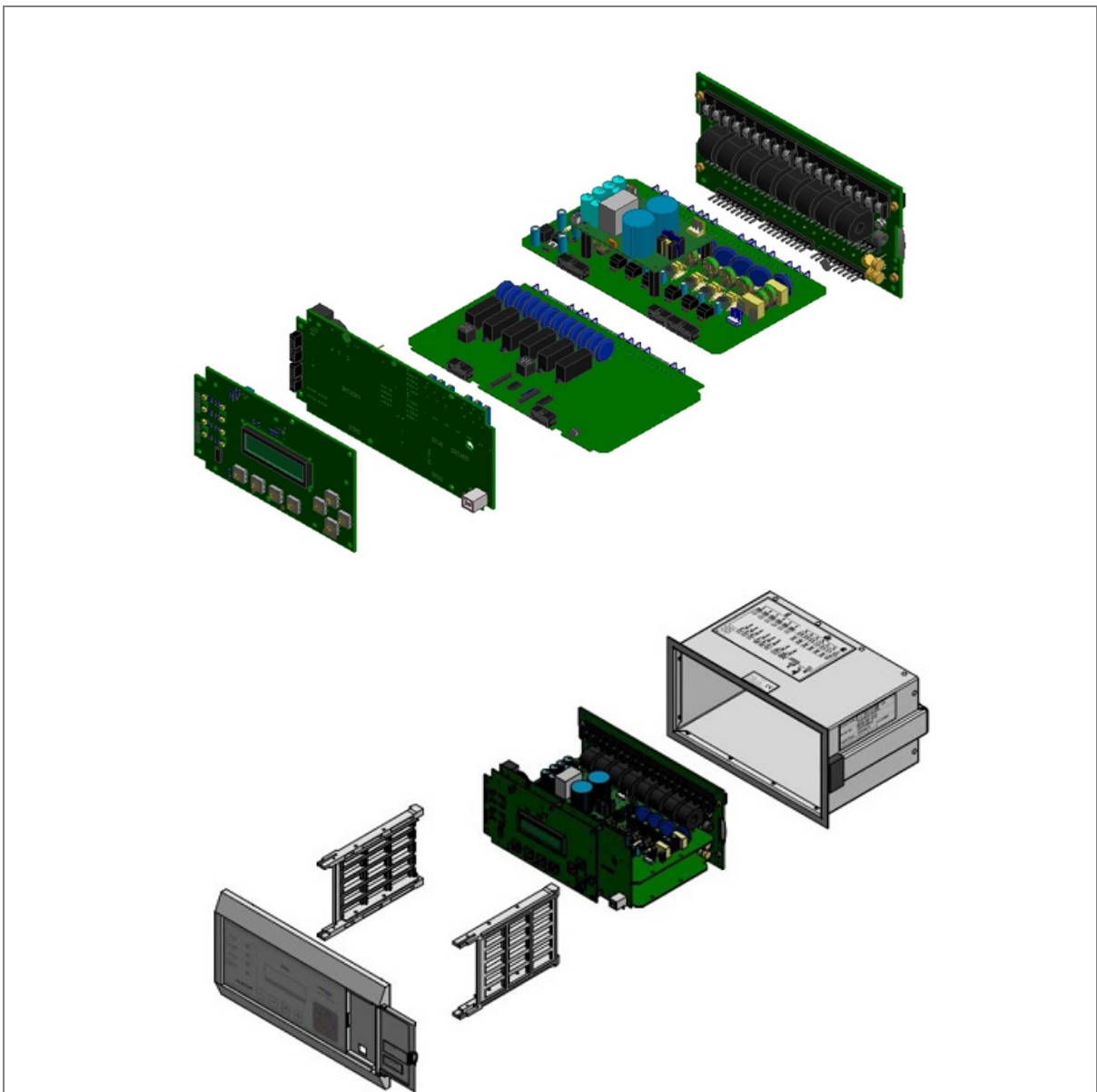

Figure 1: P652 general assembly

2.1 Overview of hardware design

The P652 hardware design overview is explained with the help of the schematic diagram. The P652 hardware consists of eight sets of internal Current Transformers (CTs). These internal CTs are basically designed to cater to Protection & metering requirements. Dedicated CTs are available for the earth fault protection requirements. The relay also has provision for the built-in SMPS unit which accepts power supply input of 24-230 V AC/DC from external source and outputs 12 V and 24 V DC for internal circuitry. The current signals acquired as analogue inputs get processed through operational amplifier, filter circuit, multiplexer, ADC (Analog to digital converter) and finally fed to CPU.

The CPU design is a hybrid of the digital signal processor (DSP) and high speed microcontroller which runs complex algorithm for deriving the fundamental & harmonic component from the input current signals. The digital inputs and outputs modules are designed to interface the monitoring, control and protection signals through optically isolated circuit as per the field requirements. The other peripherals modules like 16x2 LCD display, feather touch keys, USB and RS485 communication interfaces, battery backup for RTC and built in memory circuits are integrated as per the schematic diagram and enclosed in the IP-52 enclosure.

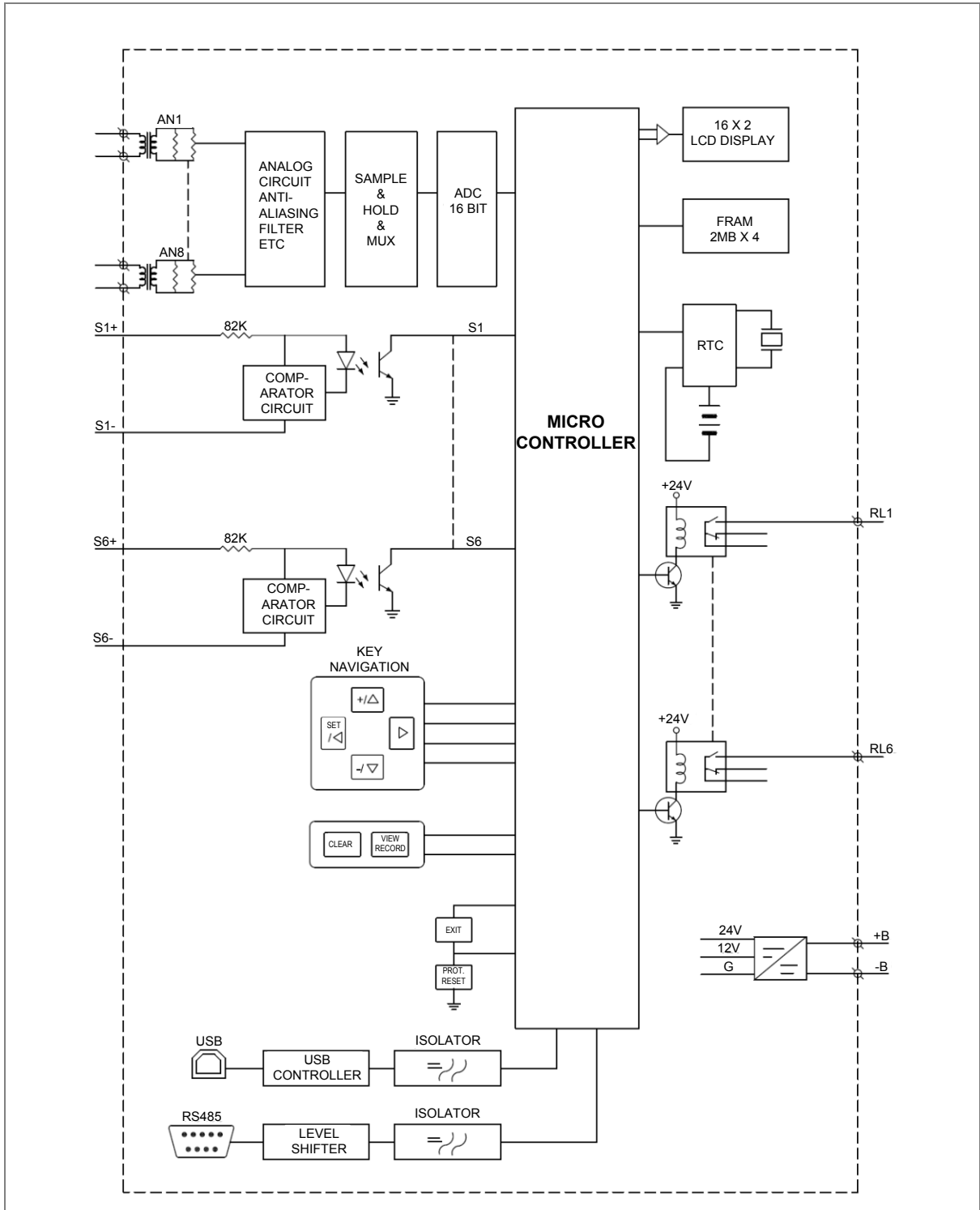

Figure 2: Hardware design overview

2.2 Microcontroller with DSP module

The hardware is designed around 32 bit controller housed in small 100 pin SMD package. It is a high speed fix point Controller having MIPS's M4K® 32-bit core with 5-stage pipeline capable of operating up to 200 MHz. This controller is referred as MCU (Microcontroller unit).

2.2.1 Microcontroller module (Processor board) features

- 2MB Flash memory (plus an additional 160 KB of Boot Flash)
- 512KB on chip SRAM memory
- Multiple interrupt vectors with individually programmable priority
- Fail-Safe Clock Monitor mode
- Configurable Watchdog Timer with on-chip Low-Power RC oscillator for reliable operation
- Internal 8 MHz and 32 kHz oscillators
- Six UART modules with RS-232, RS-485 , USB and LIN support
- Six SPI modules
- Five I2C™ modules
- Hardware Real-Time Clock and Calendar (RTCC)
- Nine 16-bit Timers/Counters

2.3 Microcontroller and analog measurement

P652 hardware supports 8 analog inputs. The relay hardware uses external 16 bit ADC converter with capability to sample all 8 signals simultaneously to avoid any phase angle error and achieve higher accuracy. This external ADC can measure input in a range of – 10 V to +10 V. The ADC is interfaced using SPI serial interface, to avoid any software delays. The MCU continuously monitors different analog signals like line and E/F currents through CTs, multiplexer and ADC.

The relay is designed for 5 amp and 1 amp CT secondary current signal (ordering option for Phase CTs). These inputs are further scaled down to low voltage signal by using internal current and transformer. The internal current transformer converts nominal current signal to 3.3mA. These analog signals are then passed through protection circuit, anti-aliasing filter and amplifier which scales analogue signal to required ADC range. This anti-aliasing filter blocks all high frequency components and surges to avoid measurement error. The sample and hold (S/H) circuit and multiplexer sample all analog signals at same instant to avoid and phase angle error and give maximum accuracy.

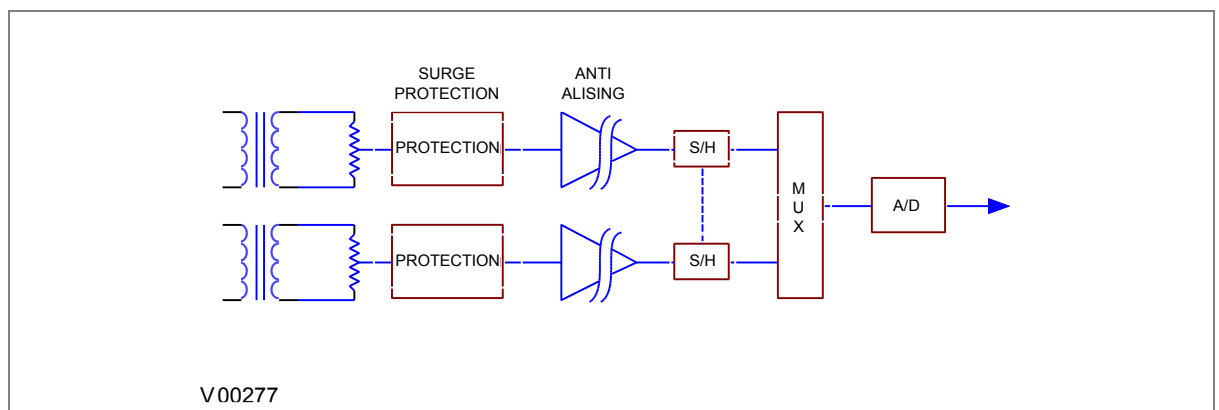

Figure 3: Analog signal processing

The MCU acquires analog values @ 16 samples per cycle. Digital signal processing (DSP) performs powerful numerical algorithms which convert this signal in to equivalent vectors. Once the signal is converted into vectors, number of parameters are derived from it such as phase currents (I_a, I_b, I_c), positive sequence current (I₁), negative sequence current (I₂) etc. The MCU also calculates 2nd and 5th harmonic content which is then utilised for inrush/transient overfluxing condition respectively. All measurements are tuned to fundamental frequency i.e. 50 Hz or 60 Hz, so that relay will remain stable during distorted waveform generated by modern electronics load.

The typical Frequency response of tuned filter for 50 Hz is as shown in figure 4.

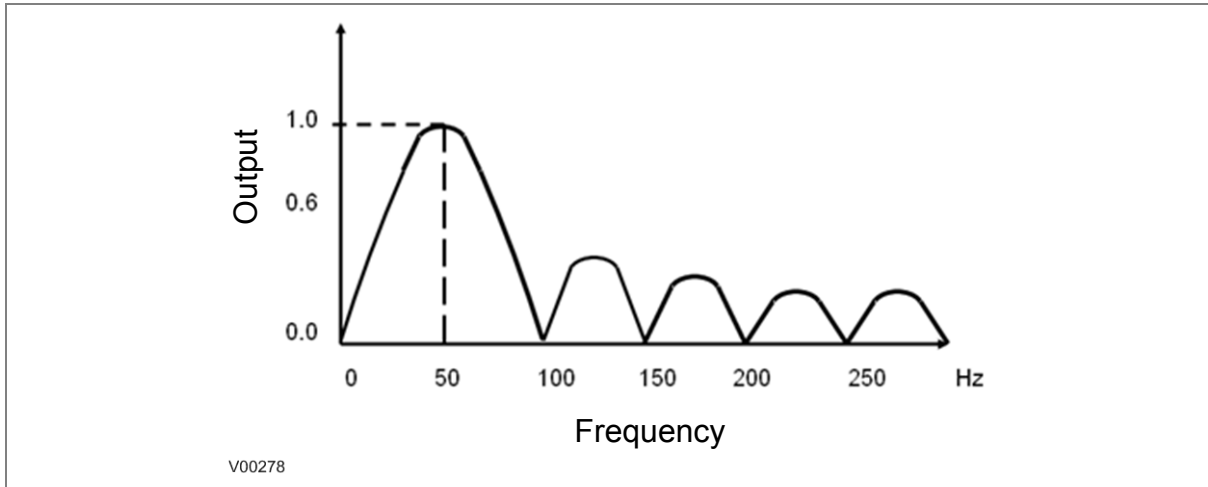

Figure 4: Frequency response of tuned filter for 50 Hz

The measurement is totally immune to all higher harmonics which makes relay operation absolute reliable. All these measured values are then used for different protection functions such as over current/Earth Fault and Negative phase sequences. The actual protection function depends on type of relay and described in the rest of the document.

2.4 Digital input /output module

This module supports 6 numbers of Digital input DI and 6 numbers of Digital output DO channels for acquiring filed signals or controlling field devices respectively. The DIs are isolated from other circuits by using Opto isolators. The threshold voltage at which Opto coupler turns ON is controlled by comparator based on the voltage range selected during device ordering.

2.5 Power supply module

The Power supply module is a designed using modern PWM based switching mode technique. It converts input supply to the 12 V and 24 VDC low voltage supply for relay electronics and control circuit. It also provides necessary isolation from input power supply. The Normal operating voltage range is 24 V – 230 VAC/DC.

2.6 Communication module

P652 supports 2 numbers of isolated ports for communication.

- (a) USB port provided on front of the relay
- (b) RS 485 (2 wired) port provided on the rear side of relay.

The relay can be accessed using the P50 Agile Configurator. Rear port supports open protocols like IEC60870-5-103/MODBUS or DNP3.0 (ordering option) and is used for external communication.

2.7 Human machine interface module

The HMI module is provided with 16x2 LCD, 8 numbers of soft feather touch keys and 8 numbers of LEDs for indication. The cover at right side of the front panel houses following:

- Female USB connector
- Serial number of relay.

- Model number of relay.
- Voltage and Current ratings.

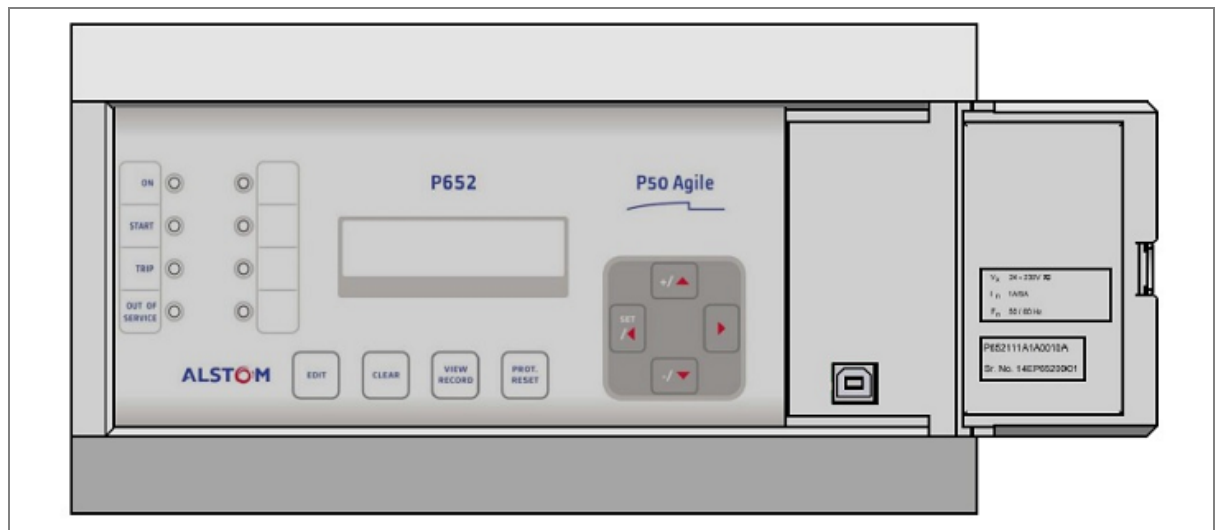

Figure 5: Front panel of P652 relay

FRONT PANEL

CHAPTER 4

1 CHAPTER OVERVIEW

This chapter consists of the following sections:

- 1 Chapter Overview**
- 2 Front Panel**
 - 2.1 User interface
 - 2.1.1 LCD display
 - 2.1.2 Touch keys
 - 2.1.3 LEDs
 - 2.1.4 RS 485 port
 - 2.1.5 USB port

2 FRONT PANEL

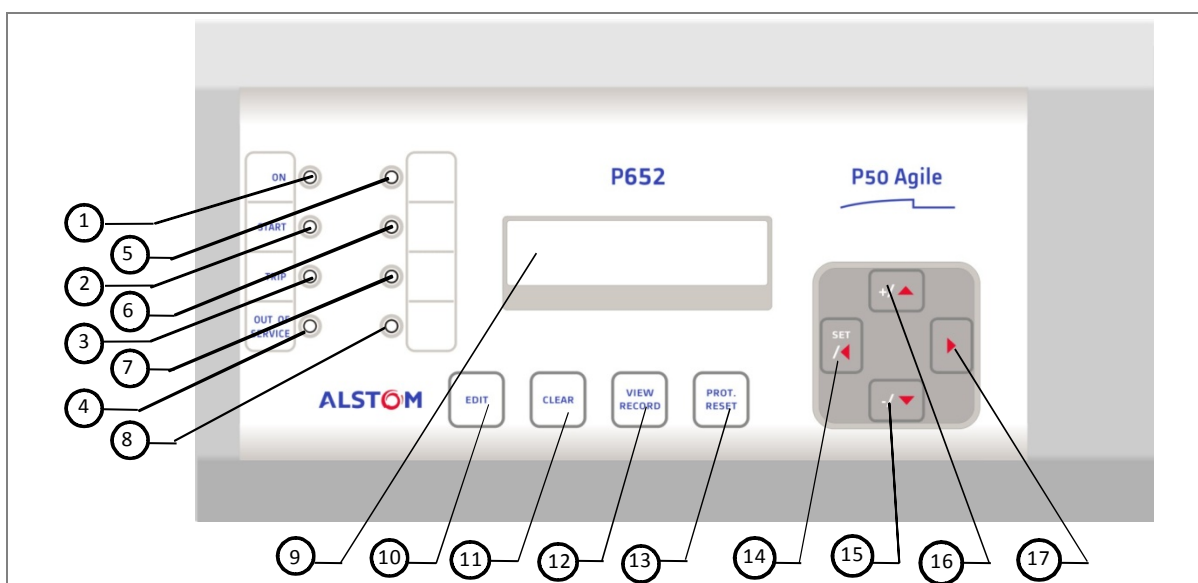

Figure 1: Front panel

SL no	Label	Function
1	ON	Green LED indicates that the IED is in correct working order, and should be ON at all times. It turns red if the unit's self-tests show there is an error in the hardware or software.
2	START	Amber LED flashes when the IED registers an alarm. This may be triggered by a fault, event or maintenance record. The LED flashes until the alarms have been accepted (read) by pressing VIEW RECORD function key, then changes to constantly ON. When the alarms are cleared, the LED switches OFF after pressing CLEAR key.
3	TRIP	Red LED switches ON when the IED issues a trip signal. When the faults are cleared, the LED switches OFF after pressing CLEAR key.
4	OUT OF SERVICE	Amber LED flashes when the IED's protection is unavailable (eg. Setting Error, ADC Error detected by unit's self-test etc)
5	L5	Programmable dual colour LED
6	L6	Programmable dual colour LED
7	L7	Programmable dual colour LED
8	L8	Programmable dual colour LED
9	LCD Display	The LCD display is used to view the settings and parameters of the relay.
10	EDIT	Feather touch key to edit parameter settings.
11	CLEAR	Feather touch key to clear the fault LED indications. Also used to discard the setting changes.
12	VIEW RECORD	Feather touch key to view fault records.
13	PROT. RESET	Feather touch key to reset the hardware. This key to be used along with EDIT key. The relay will reboot when 'PROT. RESET' + 'EDIT' is pressed simultaneously.
14	SET / ◀	Feather touch key SET to save the settings and / ◀ is used for navigating through the menus/submenus.
15	+ / ▲	Feather touch key [+] is used to INCREASE the values and [▲] is used to change the menu level or change between settings in a particular menu.
16	- / ▼	Feather touch key [-] is used to DECREASE the values and [▼] is used to change the menu level or change between settings in a particular menu.

SL no	Label	Function
17	▶	Feather touch key [▶] is used to view the settings and to navigate through the menus and submenus.









2.1 User interface

2.1.1 LCD display

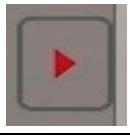
A backlit LCD display of 16 x 2 characters is provided for parameter and setting display, and for easy viewing of measurement, setting, fault records, date & time and error messages. The backlit display will switch off automatically after 100 seconds if no key is pressed. The backlit display will turn **ON** automatically if any tripping occurs.

2.1.2 Touch keys

The function of the relay is controlled by the following keys on the front panel.

	(+) key is used to INCREASE the values (▲) key is used to change the menu level or change between settings in a particular menu.
	SET key is used to save the settings (◀) key is used for navigating through the menus/submenus.
	(▶) key is used to view the settings and to navigate through the menus and submenus.
	(-) key is used to DECREASE the values (▼) key is used to change the menu level or change between settings in a particular menu.
	EDIT key is used to edit the setting
	CLEAR key is used to clear the fault LED indications. This key is also used to discard the setting changes.
	VIEW RECORD key is used to view the Fault, Maintenance and Event Records.
	PROT. RESET key is used for Hardware reset. This key is interlocked with EDIT key. This key is not required to be pressed in normal operation, but is used to reset the hardware of relay during a relay firmware update.

Note: If changes are not made within 100 s while editing the settings then the display will reset itself and return to the Main Menu.

2.1.3 LEDs

The P652 Relay has 8 high-intensity LEDs for easy identification of fault type and ease of user interface.

SL no	Label	Function
LED 1	ON	The Green LED indicates that the IED is in correct working order, and should be ON at all times. It turns red if the unit's self-tests show there is an error in the hardware or software.
LED 2	START	The Amber LED flashes when the IED registers an alarm. This may be triggered by a fault, event or maintenance record. The LED flashes until the alarms have been accepted (read) by pressing VIEW RECORD function key, then changes to constantly ON. When the alarms are cleared, the LED switches OFF after pressing CLEAR key.
LED 3	TRIP	The Red LED switches ON when the IED issues a trip signal. When the faults are cleared, the LED switches OFF after pressing CLEAR key.
LED 4	OUT OF SERVICE	The Amber LED flashes when the IED's protection is unavailable (eg. Setting Error, ADC Error detected by unit's self-test etc)
LED 5,6,7,8	-	Programmable dual colour LED

2.1.4 RS 485 port

RS485 port is provided at the rear of relay (near to terminal block) for permanent SCADA connectivity. The separate 5 Pin connector is used to avoid accidental connection of power wiring to communication input. The RS485 port can be used to download Settings, Fault data, Live Events and Disturbance Records.

2.1.5 USB port

The USB port is situated on the front panel in the bottom right hand corner, and can be accessed by opening the flap on the front of the relay. This port is used to communicate with a locally connected PC.

It has three main purposes:

- Transferring settings information to/from the PC from/to the device.
- Downloading firmware updates.
- Downloading relay data for analysis.

The port is intended for temporary connection during testing, installation and commissioning. It is not intended to be used for permanent SCADA communications.

You can connect the unit to a PC with a USB cable up to 15 m in length.

The USB port includes a USB full-speed function controller, USB transceiver, oscillator, EEPROM, and synchronous serial data bus (UART). No other external USB components are required.

For configuration/setting, appropriate 'Config port' has to be selected from the **SYSTEM DATA** menu.

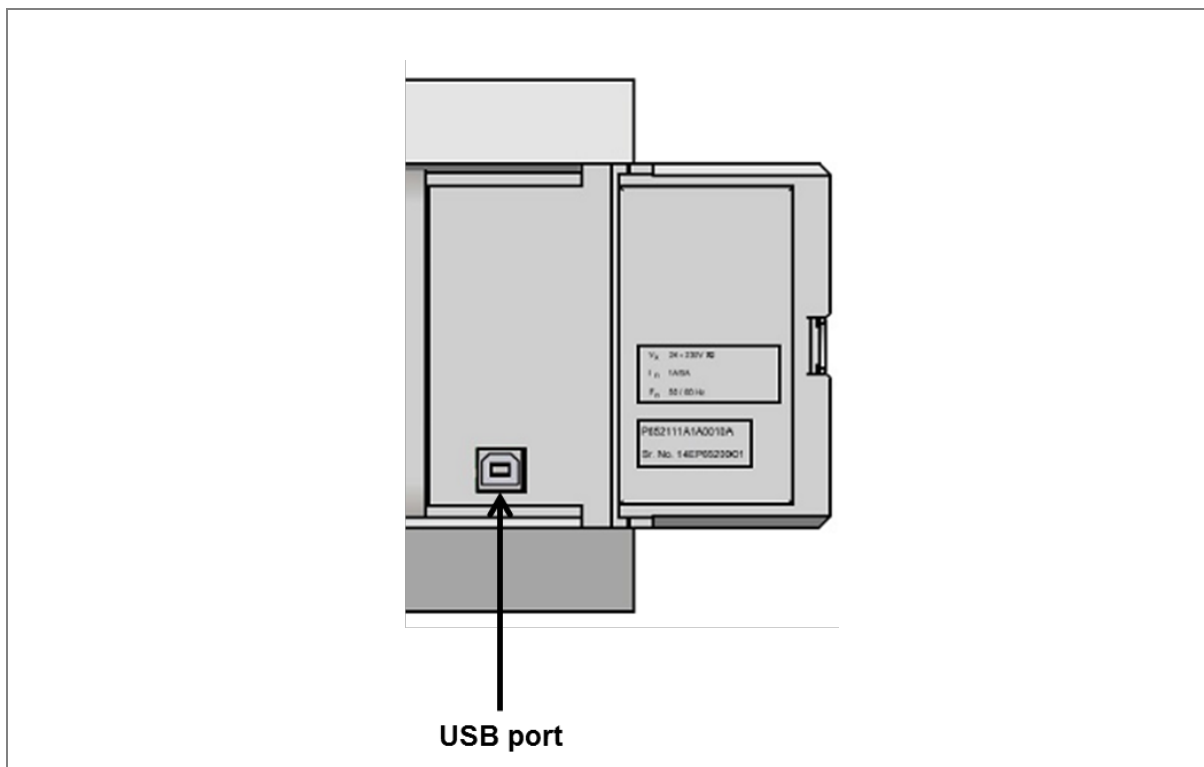

Figure 2: USB port

CONFIGURATION

CHAPTER 5

1 CHAPTER OVERVIEW

This chapter consists of the following sections:

- 1 Chapter Overview**
- 2 Configuration**
 - 2.1 Changing the settings
 - 2.2 Password entry
 - 2.3 Menus
 - 2.3.1 Default display
 - 2.3.2 Main Menu contents
 - 2.3.3 System Data menu
 - 2.3.3.1 View/edit settings
 - 2.3.4 View Records menu
 - 2.3.4.1 View Records menu contents
 - 2.3.4.2 View Fault Records
 - 2.3.4.3 View Event Records
 - 2.3.4.4 View Maintenance Records
 - 2.3.4.5 View Alarm Records
 - 2.3.5 Measurement menu
 - 2.3.5.1 View contents - Measurement 1 submenu
 - 2.3.5.2 View contents - Measurement 2 submenu
 - 2.3.5.3 View contents - Measurement 3 submenu
 - 2.3.6 CB Control menu
 - 2.3.6.1 View/edit settings (if all settings are disabled)
 - 2.3.6.2 View/edit settings (if all settings are enabled)
 - 2.3.7 Date and Time menu
 - 2.3.7.1 Edit settings (if the settings are disabled)
 - 2.3.7.2 Edit settings (if the settings are enabled)
 - 2.3.8 Configuration menu
 - 2.3.8.1 View/edit settings
 - 2.3.9 Transformer Ratios menu
 - 2.3.9.1 View/edit settings
 - 2.3.10 Record Control menu
 - 2.3.10.1 View/edit settings
 - 2.3.11 Communication menu
 - 2.3.11.1 View/edit settings
 - 2.3.12 I/O Configuration menu
 - 2.3.12.1 View/edit settings
 - 2.3.12.2 List of the submenus for Relay Output, LEDs and AND Logic configuration
 - 2.3.13 O/P Relay Configuration menu
 - 2.3.13.1 View/edit settings
 - 2.3.14 Disturbance Record menu
 - 2.3.14.1 View/edit settings
 - 2.3.15 Commissioning Test menu
 - 2.3.15.1 View/edit settings
 - 2.3.16 Group 1 menu
 - 2.3.16.1 Edit settings
 - 2.3.16.2 Group1 –System Configuration submenu
 - 2.3.16.3 Group1 – Differential Protection submenu
 - 2.3.16.4 Group1 – REF Protection submenu
 - 2.3.16.5 Group1 – Overcurrent submenu
 - 2.3.16.6 Group1 – Negative Sequence Overcurrent submenu
 - 2.3.16.7 Group 1 – Earth Fault submenu
 - 2.3.16.8 Group1 – Thermal Overload submenu
 - 2.3.16.9 Group 1 – CB Fail submenu

- 2.3.16.10 Group 1 – Through Fault submenu
- 2.3.17 Group 2 menu
- 2.3.17.1 Edit settings
- 2.4 Configuration flowcharts
- 2.4.1 Main menu
- 2.4.2 View and Edit settings
- 2.4.3 View System Data menu settings
- 2.4.4 View Records menu
- 2.4.4.1 View content
- 2.4.4.2 View Fault Records
- 2.4.4.3 View Event Records
- 2.4.4.4 View Maintenance Records
- 2.4.4.5 View Alarm Records
- 2.4.5 Measurement menu
- 2.4.5.1 View Measurement 1
- 2.4.5.2 View Measurement 2
- 2.4.5.3 View Measurement 3
- 2.4.6 CB Control menu
- 2.4.6.1 View/edit settings (if all settings are disabled)
- 2.4.6.2 View/edit settings (if all settings are enabled)
- 2.4.7 Date and Time menu
- 2.4.7.1 View/edit settings (if all settings are disabled)
- 2.4.7.2 View/edit settings (if all settings are enabled)
- 2.4.8 Configuration menu
- 2.4.8.1 View/edit settings
- 2.4.9 Transformer Ratios menu
- 2.4.9.1 View/edit settings
- 2.4.10 Record Control menu
- 2.4.10.1 View/edit settings
- 2.4.11 Communication menu
- 2.4.12 View/edit settings
- 2.4.13 I/O Configuration menu
- 2.4.14 View/edit settings
- 2.4.15 O/P Relay Configuration menu
- 2.4.15.1 View/edit settings
- 2.4.16 Disturbance Record menu
- 2.4.16.1 View/edit settings
- 2.4.17 Commissioning Test menu
- 2.4.17.1 View/edit settings
- 2.4.18 Group1 menu
- 2.4.18.1 View/edit settings
- 2.4.18.2 Group1 System Configuration submenu
- 2.4.18.3 Group1 DIFF PROTECTION submenu
- 2.4.19 Group1 REF PROTECTION submenu
- 2.4.19.2 View/edit settings (If LV REF Protection setting is enabled)
- 2.4.19.3 Group1 Overcurrent submenu
- 2.4.20 Negative Sequence Overcurrent menu
- 2.4.20.1 View/edit settings (If setting is disabled)
- 2.4.20.2 View/edit settings- HV NEG SEQ O/C (If setting is enabled for IEC curve)
- 2.4.20.3 View/edit settings- HV NEG SEQ O/C (If setting is enabled for IEEE curve)
- 2.4.20.4 View/edit settings- HV NEG SEQ O/C (If setting is enabled for DT)
- 2.4.21 Group 1- Earth Fault submenu
- 2.4.21.1 View/edit settings- HV Earth Fault (If setting is disabled)
- 2.4.21.2 View/edit settings- HV Earth Fault (If setting is enabled for IEC curve)
- 2.4.21.3 View/edit settings- HV Earth Fault (If setting is enabled for IEEE curve)
- 2.4.21.4 View/edit settings- HV Earth Fault (If setting is enabled for DT)

- 2.4.22 Group 1-Thermal Overload submenu
 - 2.4.22.1 View/edit settings (If Characteristics is disabled)
 - 2.4.22.2 View/edit settings (If Characteristics is set as Single)
- 2.4.23 Group 1-CB Fail submenu
 - 2.4.23.1 View/edit settings- HV CB FAIL
- 2.4.24 Group 1- Through Fault submenu
 - 2.4.24.1 View/edit Settings (If function is enabled)
- 2.4.25 Group 2 menu
 - 2.4.25.1 View/edit settings

2 CONFIGURATION

Each product has different configuration parameters according to the functions it has been designed to perform. There is, however, a common methodology used across the entire product to set these parameters.

This chapter describes an overview of this common methodology, as well as providing concise instructions of how to configure the device.

Using the HMI, you can:

- Display and modify settings
- View the digital I/O signal status
- Display measurements
- Display fault records
- Reset fault and alarm indications

The keypad provides full access to the device functionality by means of a range of menu options. Information is displayed on the LCD.

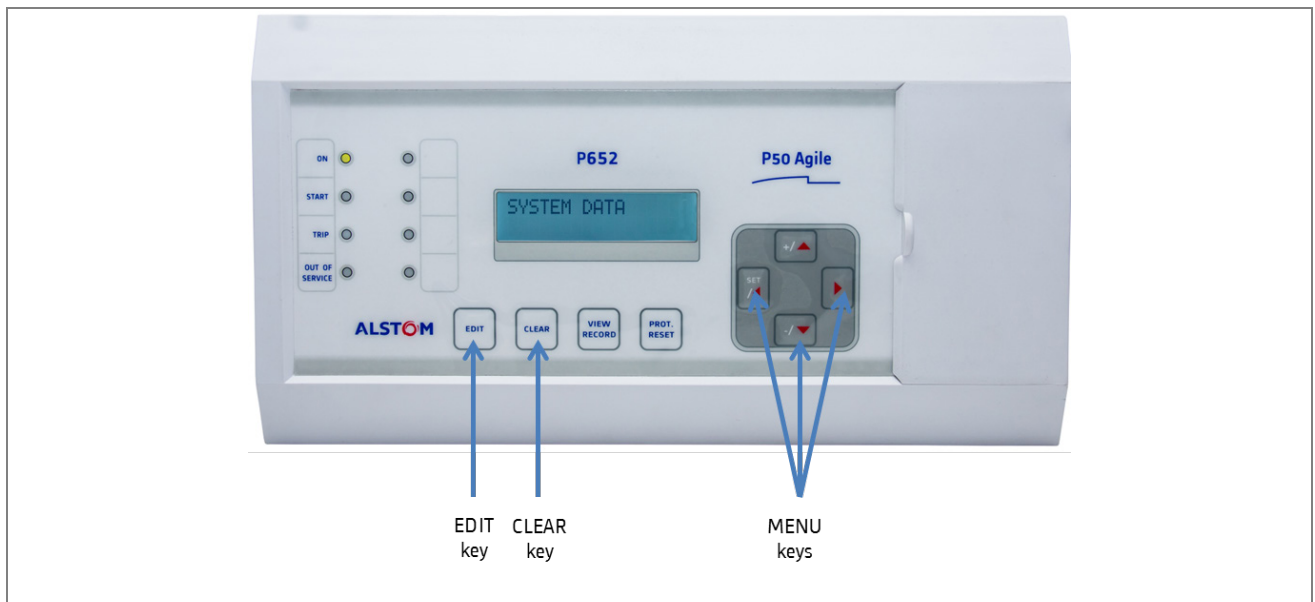

Figure 1: P652 menu/function keys

2.1 Changing the settings

<div style="border: 2px solid black; padding: 5px; text-align: center;">SYSTEM DATA</div>	<p>Step 1: Press the (▶) key to move to the next option.</p>
<div style="border: 2px solid black; padding: 5px;"> Language English </div>	<p>Step 2: Press the (- / ▼) key to move to the next option till the relay displays CB Open/Close setting</p>
<p style="text-align: center;">:::</p>	<p style="text-align: center;">:::</p>
<div style="border: 2px solid black; padding: 5px;"> CB Open/Close Open </div>	<p>Step 3: Press the (- / ▼) key till the relay displays this option.</p> <p>Press 'EDIT' key to edit the setting.</p>
<div style="border: 2px solid black; padding: 5px;"> Password = 0001 </div>	<p>[All editable settings are password protected so when the 'EDIT' key is pressed, it will display the password and the settable number/text will start blinking].</p> <p>Step 4: Enter the password by using the (+ / ▲) or the (- / ▼) key. The Password is four (4) digits alpha numeric.</p>
<div style="border: 2px solid black; padding: 5px;"> Password = 0000 ** Password OK ** </div>	<p>Step 5: After editing the Password, press the 'EDIT' key, the Password OK message is displayed and settable number/text will start blinking and the relay will move to the next option.</p> <p>Note: When the password is set, modification can be done in any settings within 15minutes. After the lapse of 15 minutes the relay will once again ask to re-enter the password.</p>
<div style="border: 2px solid black; padding: 5px;"> CB Open/Close Open </div>	<p>Step 6: By using the (+ / ▲) or (- / ▼) key, the desired selection can be set as shown in the display.</p>
<div style="border: 2px solid black; padding: 5px;"> CB Open/Close Close </div>	<p>Step 7: After setting, press the 'EDIT' key, the text will stop blinking and move to the next option.</p> <p>Step 8: Press the (◀) / (▶) key, it will ask if you want to save the settings and move to the next option.</p>
<div style="border: 2px solid black; padding: 5px;"> SET For Save CLEAR For Cancel </div>	<p>Step 9: When the 'SET' key is pressed again, it will save the changes and move to the next option.</p>
<div style="border: 2px solid black; padding: 5px; text-align: center;">SAVE Settings</div>	<p>This window will flash for a moment and the control will return to the main menu.</p>
<div style="border: 2px solid black; padding: 5px; text-align: center;">SYSTEM DATA</div>	

Note: The user can DISCARD SETTINGS by using the CLEAR Key.

<p>SET For Save CLEAR For Cancel</p>	<p>Step 10: When the 'CLEAR' key is pressed, it will discard the changes and the relay will move to the next option.</p>
<p>DISCARD Settings</p>	<p>This window will flash for a moment and the control will return to the main menu.</p>
<p>SYSTEM DATA</p>	

2.2 Password entry

Modification of the editable settings requires password access. You will be prompted for a password before you can make any changes, as follows. The default password is **0000**.

1. On pressing the 'EDIT' key, a flashing cursor appears at the right most character field of the password by default. Press the up or down cursor keys to change each character.
2. Use the left and right cursor keys to move between the character fields of the password.
3. Press the 'SET' key to confirm the password. After entering a valid password the **Password OK** message appears indicating that the password is correct. The user can now start editing the settings. If the correct password has not been entered, the password prompt page appears again. To stop this prompt press the 'CLEAR' key.
4. A new password can be set using the **Password** cell in the **SYSTEM DATA** menu.
5. If the keypad is inactive for 15 minutes the user will again be prompted for a password entry.

2.3 Menus

2.3.1 Default display

After **Power ON** or when the PROT.RESET + EDIT key is pressed, the relay will display the following message.

<p>P50 Agile P652 Trafo. Protect'n</p>	<p>This window will flash momentarily showing the following. Relay Name: P50 Agile P652, Relay Type: Transformer Protection Then the control will automatically move to next option.</p>
<p>ID = 1 SW = V1.00</p>	<p>This window will flash momentarily showing the following:- Unit ID = 1 Software Version =V1.00 Then the control will automatically move to the default window.</p>

SYSTEM DATA	

2.3.2 Main Menu contents

SYSTEM DATA	<p>Password protected window for “SYSTEM DATA” setting i.e. Language, Description, Model Number, Serial Number, Software Version, Frequency, USB Address, USB Parity, USB Baud Rate, Password, Active Group, Opto I/P Status, Relay O/P Status, HV CB Open/Close, LV CB Open/Close, Opto I/P and Config Port.</p>
VIEW RECORDS	<p>Menu to view Fault Record, Event Record, Maint Record and Alarm records.</p>
MEASUREMENTS	<p>This menu displays the measurements values of various parameters (i.e. Phase current, measured and derived earth current, negative, positive phase sequence current and I2/I1 ratio as per per phase / earth CT ratio, TC (Trip Counter), BOC (Breaker Operation Counter), BOT (Breaker Operating Time), Th State (Thermal State) and rms value of phase currents.</p>
CB CONTROL	<p>Password protected window for “CB CONTROL – HV CB CONTROL & LV CB CONTROL” settings i.e. TCS Alarm, TCS Timer, CB Open S’vision (Enabled / Disabled), CB Open Time, CB Open Alarm (Enabled / Disabled), CB Open Oper, CB Control By, Close Pulse Time, Open Pulse Time .</p>
DATE AND TIME	<p>Password protected window for “DATE AND TIME” settings i.e. Local Time Enable, Local Time Offset, DST Enable, DST Offset, DST Start, DST Start Day, DST Start Month, DST Start Mins, DST End, DST End Day, DST End Month, DST End Mins, RP Time Zone, SET Hours, SET Minutes, SET Seconds, SET Date, SET Month and SET Year.</p>
CONFIGURATION	<p>Password protected window for “CONFIGURATION” settings i.e. Restore Defaults, Active Settings, Copy From, Copy To, Setting Group 1 (Enabled/Disabled), Setting Group 2 (Enabled/Disabled), System Config (Enabled/Disabled), Diff Protection (Enabled/Disabled), HV REF (Enabled/Disabled), LV REF (Enabled/Disabled), HV Overcurrent (Enabled/Disabled), LV Overcurrent (Enabled/Disabled), HV Neg Sequence O/C (Enabled/Disabled), LV Neg Sequence O/C (Enabled/Disabled), HV Earth Fault (Enabled/Disabled), LV Earth Fault (Enabled/Disabled), Thermal Overload (Enabled/Disabled), HV CB Fail (Enabled/Disabled), LV CB Fail (Enabled/Disabled), Through Fault (Enabled/Disabled), Measure’t Setup and Setting Values.</p>
TRANS. RATIOS	<p>Password protected window for “TRANS. RATIO” settings i.e HV Ph CT Prim’y, HV Ph CT Sec’y, LV Ph CT Prim’y, LV Ph CT Sec’y, HV REF CT Prim’y, HV REF CT Sec’y, LV REF CT Prim’y and LV REF CT Sec’y</p>

<div style="border: 2px solid black; padding: 5px; text-align: center;">RECORD CONTROL</div>	Password protected window for “ RECORD CONTROL ” settings i.e. Clear Events (Yes/No), Clear Faults (Yes/No), Clear Dist Recs (Yes/No), Clear Maint (Yes/No), Reset HV CB data (Yes/No), Reset LV CB data (Yes/No) and Thermal Reset (Yes/No).
<div style="border: 2px solid black; padding: 5px; text-align: center;">COMMUNICATION</div>	Password protected window for “ COMMUNICATION ” settings i.e. RP1 Address, RP1 Baud Rate, RP1 Parity and RP1 Timesync.
<div style="border: 2px solid black; padding: 5px; text-align: center;">IO CONFIGURATION</div>	Password protected window for “ IO CONFIGURATION ” settings i.e. Relay, LED G, LED R, AND Logic and Opto I/P.
<div style="border: 2px solid black; padding: 5px; text-align: center;">O/P RELAY CONFIG</div>	Password protected window for “ O/P RELAY CONFIGURATION ” settings i.e. Contact HR/SR, O/P-1 Open Time, O/P-2 Open Time, O/P-3 Open Time, O/P-4 Open Time, O/P-5 Open Time and O/P-6 Open Time, LED G HR/SR, LED R HR/SR, ANDEQ A Op Time, ANDEQ A Rst Time, ANDEQ B Op Time, ANDEQ B Rst Time, ANDEQ C Op Time, ANDEQ C Rst Time, ANDEQ D Op Time and ANDEQ D Rst Time.
<div style="border: 2px solid black; padding: 5px; text-align: center;">DISTURBANCE REC</div>	Password protected window for “ DISTURBANCE RECORD ” settings i.e. Trigger Position.
<div style="border: 2px solid black; padding: 5px; text-align: center;">COMMISSION. TEST</div>	Password protected window for “ COMMISSIONING TEST ” settings i.e. Test Mode, Test Pattern, Contact Test and Test LEDs.
<div style="border: 2px solid black; padding: 5px; text-align: center;">GROUP 1</div>	Password protected window for “ GROUP 1 ” settings i.e. SYSTEM CONFIG, DIFF PROTECTION, REF PROTECTION, OVERCURRENT, NEG SEQUENCE O/C, EARTH FAULT, THERMAL OVERLOAD, CB FAIL and THROUGH FAULT. <i>Note: Group1 settings will be seen only when it is enabled and set under Active Settings in Configuration menu.</i>
<div style="border: 2px solid black; padding: 5px; text-align: center;">GROUP 2</div>	Password protected window for “ GROUP 2 ” settings i.e. SYSTEM CONFIG, DIFF PROTECTION, REF PROTECTION, OVERCURRENT, NEG SEQUENCE O/C, EARTH FAULT, THERMAL OVERLOAD, CB FAIL and THROUGH FAULT. <i>Note: Group2 settings will be seen only when it is enabled and set under Active Settings in Configuration menu.</i>

2.3.3 System Data menu

2.3.3.1 View/edit settings

<div style="border: 2px solid black; padding: 5px; text-align: center;"> SYSTEM DATA </div>	Password protected window for “ SYSTEM DATA ” settings i.e. Language, Description, Model Number, Serial Number, Software Version, Frequency, USB Address, USB Parity, USB Baud Rate, Password, Active Group, Opto I/P Status, Relay O/P Status, HV CB Open/Close, LV CB Open/Close, Opto I/P and Config Port.
<div style="border: 2px solid black; padding: 5px;"> Language English </div>	Read-only This window shows user interface is in English Language .
<div style="border: 2px solid black; padding: 5px;"> Description P50 Agile P652 </div>	Read-only This window shows Description of the relay.
<div style="border: 2px solid black; padding: 5px;"> Model Number P652121A1A0010A </div>	Read-only This window shows the Model Number of the relay.
<div style="border: 2px solid black; padding: 5px;"> Serial Number xxxP652xxxx </div>	Read-only This window shows the Serial Number of the relay.
<div style="border: 2px solid black; padding: 5px;"> Software Version P652_1__1_0V1.00 </div>	Read-only This window shows the Software Version of the relay.
<div style="border: 2px solid black; padding: 5px;"> Frequency 50Hz </div>	Editable setting This window shows the System Frequency . The desired Frequency can be selected to either 50 / 60 Hz.
<div style="border: 2px solid black; padding: 5px;"> USB Address 1 </div>	Read-only This window shows the USB Address .
<div style="border: 2px solid black; padding: 5px;"> USB Parity None </div>	Read-only This window shows the USB Parity .

<div style="border: 2px solid black; padding: 5px;"> <p>USB Baud Rate 57600</p> </div>	<p>Read-only This window shows the USB Baud Rate</p>
<div style="border: 2px solid black; padding: 5px;"> <p>Password ****</p> </div>	<p>Editable setting This window is for setting the new Password of the relay. The desired alpha numeric case sensitive password can be selected from 0000 to zzzz and each digit can be set i.e. 0 to 9 / A to Z / a to z.</p>
<div style="border: 2px solid black; padding: 5px;"> <p>Active Group Group 1</p> </div>	<p>Read-only This window shows the Active Group selected in configuration.</p>
<div style="border: 2px solid black; padding: 5px;"> <p>Opto I/P 654321 Status 000000</p> </div>	<p>Read-only This window shows the Opto Input status.</p>
<div style="border: 2px solid black; padding: 5px;"> <p>Relay O/P 654321 Status 000000</p> </div>	<p>Read-only This window shows the Relay Output status.</p>
<div style="border: 2px solid black; padding: 5px;"> <p>HV CB Open / Close No operation</p> </div>	<p>Editable setting This window allows selection of the desired HV CB operation i.e. Open, Close and No operation.</p>
<div style="border: 2px solid black; padding: 5px;"> <p>LV CB Open / Close No operation</p> </div>	<p>Editable setting This window allows selection of the desired LV CB operation i.e. Open, Close and No operation.</p>
<div style="border: 2px solid black; padding: 5px;"> <p>Opto I/P DC</p> </div>	<p>Editable setting This window allows selection of voltage input type for the Opto I/P i.e. AC / DC.</p>
<div style="border: 2px solid black; padding: 5px;"> <p>Config Port USB</p> </div>	<p>Editable setting This window allows selection of the Configuration Port of the relay i.e. USB / RP</p>

2.3.4 View Records menu

2.3.4.1 View Records menu contents

<div style="border: 2px solid black; padding: 5px; text-align: center;">VIEW RECORDS</div>	Menu to view Fault Record, Event Record, Maint Record and Alarm record.
<div style="border: 2px solid black; padding: 5px; text-align: center;">Fault Record</div>	This window is to view the Fault Record
<div style="border: 2px solid black; padding: 5px; text-align: center;">Event Record</div>	This window is to view the Event Record
<div style="border: 2px solid black; padding: 5px; text-align: center;">Maint Record</div>	This window is to view the Maintenance Record
<div style="border: 2px solid black; padding: 5px; text-align: center;">Alarm Record</div>	This window is to view the Alarm Record

2.3.4.2 View Fault Records

<div style="border: 2px solid black; padding: 5px; text-align: center;">VIEW RECORDS</div>	Menu to view Fault Record, Event Record, Maint Record and Alarm record.
<div style="border: 2px solid black; padding: 5px; text-align: center;">Fault Record</div>	This window shows the Fault Record
<div style="border: 2px solid black; padding: 5px; text-align: center;">Fault Num = 1</div>	This window shows the Fault Number of latest fault.
<div style="border: 2px solid black; padding: 5px; text-align: center;">DIFFABC</div>	This window displays information about the protection function operation. <i>Note: Window shows DIFF protection phase A, B, C operation.</i>

<div style="border: 2px solid black; padding: 5px; width: fit-content;"> <p>ia-HV=0.00A ib-HV=0.00A</p> </div>	<p>This window shows secondary value of HV Phase A & B current</p>
<div style="border: 2px solid black; padding: 5px; width: fit-content;"> <p>ic-HV=0.00A in-HV=0.00A</p> </div>	<p>This window shows secondary value of HV Phase C & neutral current</p>
<div style="border: 2px solid black; padding: 5px; width: fit-content;"> <p>ia-LV=0.00A ib-LV=0.00A</p> </div>	<p>This window shows secondary value of LV Phase A & B current</p>
<div style="border: 2px solid black; padding: 5px; width: fit-content;"> <p>ic-LV=0.00A in-LV=0.00A</p> </div>	<p>This window shows secondary value of LV Phase C & neutral current</p>
<div style="border: 2px solid black; padding: 5px; width: fit-content;"> <p>i0-HV=0.00A i1-HV=0.00A</p> </div>	<p>This window shows secondary value of HV zero and positive sequence current</p>
<div style="border: 2px solid black; padding: 5px; width: fit-content;"> <p>i2-HV=0.00A i0-LV=0.00A</p> </div>	<p>This window shows secondary value of HV negative sequence current and LV zero sequence current</p>
<div style="border: 2px solid black; padding: 5px; width: fit-content;"> <p>i1-LV=0.00A i2-LV=0.00A</p> </div>	<p>This window shows secondary value of LV positive and negative sequence current.</p>
<div style="border: 2px solid black; padding: 5px; width: fit-content;"> <p>ia-HV rms=0.00A ib-HV rms=0.00A</p> </div>	<p>This window shows secondary value of HV RMS Phase A & B current</p>
<div style="border: 2px solid black; padding: 5px; width: fit-content;"> <p>ic-HV rms=0.00A ia-LV rms=0.00A</p> </div>	<p>This window shows secondary value of HV RMS Phase C and LV RMS Phase A current</p>
<div style="border: 2px solid black; padding: 5px; width: fit-content;"> <p>ib-LV rms=0.00A ic-LV rms=0.00A</p> </div>	<p>This window shows secondary value of LV RMS Phase B & C current</p>

ia-BIAS=0.00pu ia-DIFF=0.00pu	This window shows Bias & Diff current of Phase A
ib-BIAS=0.00pu ib-DIFF=0.00pu	This window shows Bias & Diff current of Phase B
ic-BIAS=0.00pu ic-DIFF=0.00pu	This window shows Bias & Diff current of Phase C
ThState 0%	This window shows Thermal State.
Iref HV LoZ BIAS =0.00 pu	This window shows HV REF Bias current
Iref HV LoZ DIFF =0.00 pu	This window shows HV REF Diff current
Iref LV LoZ BIAS =0.00 pu	This window shows LV REF Bias current.
Iref LV LoZ DIFF =0.00 pu	This window shows LV REF Diff current
Iref HV =0.00A Iref LV =0.00A	This window shows secondary value of HV REF and LV REF current
Trip Counter 0	This window shows Trip counter

<p>Trip Timing (Sec) 0.000</p>	This window shows Trip time.
<p>00/00/00 00:00:00:000</p>	This window shows Date & Time of Fault.

2.3.4.3 View Event Records

<p>VIEW RECORDS</p>	Menu to view Fault Record, Event Record, Maint Record and Alarm record.
<p>Fault Record</p>	This window shows the Fault Record
<p>Event Record</p>	This window shows the Event Record
<p>Event Num = 1</p>	This window shows the Event number of latest event. By using the (+ / ▲) or (- / ▼) key, the relay will scroll between Event Numbers 1 to 512.
<p>Dt: 21/06/2015 Tm: 16:15:30:225</p>	This window shows date & time of Event.
<p>Event Num = 1 Local para ON</p>	This window shows the latest Event and Event number.

2.3.4.4 View Maintenance Records

<p>VIEW RECORDS</p>	Menu to view Fault Record, Event Record, Maint Record and Alarm record.
<p>Fault Record</p>	This window will show Fault Record

<div style="border: 2px solid black; padding: 5px; text-align: center;">Event Record</div>	This window will show Event Record
<div style="border: 2px solid black; padding: 5px; text-align: center;">Maint Record</div>	This window will show Maintenance Record contents
<div style="border: 2px solid black; padding: 5px; text-align: center;"> Main't Rec Num = 1 </div>	This window shows Maintenance Record 1
<div style="border: 2px solid black; padding: 5px; text-align: center;"> Errorcode : 0004 RTC Error </div>	This window shows the contents of the Maintenance Record 1.
<div style="border: 2px solid black; padding: 5px; text-align: center;"> 07/06/2015 17:20:30.596 </div>	This window shows the date and time of error.

2.3.4.5 View Alarm Records

<div style="border: 2px solid black; padding: 5px; text-align: center;">VIEW RECORDS</div>	Menu to view Fault Record, Event Record, Maint Record and Alarm record.
<div style="border: 2px solid black; padding: 5px; text-align: center;">Fault Record</div>	This window will show the Fault Record
<div style="border: 2px solid black; padding: 5px; text-align: center;">Event Record</div>	This window will show Event Record
<div style="border: 2px solid black; padding: 5px; text-align: center;">Maint Record</div>	This window will show Maintenance Record
<div style="border: 2px solid black; padding: 5px; text-align: center;">Alarm Record</div>	This window will show Alarm Record

MatchFactor Alarm	This window shows latest alarm.
24/09/2015 12:35:40:025	This window shows the date and time of alarm.

2.3.5 Measurement menu

2.3.5.1 View contents - Measurement 1 submenu

MEASUREMENTS	Menu to view contents of Measurement 1, Measurement 2 and Measurement 3 submenu.
Measurement 1	Submenu to view measured and derived currents for HV and LV side winding.
ia-HV = 0.00 A ib-HV = 0.00 A	This window shows secondary value of current in phase A and B of HV winding, taking in to account phase CT ratio.
ic-HV = 0.00 A in-HV = 0.00 A	This window shows secondary value of current in phase C and earth current in HV winding taking in account phase CT and earth CT ratio respectively.
ia-LV = 0.00 A ib-LV = 0.00 A	This window shows secondary value of current in phase A and B of LV winding, taking in to account phase CT ratio.
ic-LV = 0.00 A in-LV = 0.00 A	This window shows secondary value of current in phase C and earth current in LV winding taking in account phase CT and earth CT ratio respectively.
i0-HV=0.00A i1-HV=0.00A	This window shows secondary value of zero and positive sequence current in HV winding.
i2-HV=0.00A i0-LV=0.00A	This window shows secondary value of negative sequence current in HV winding and zero sequence current in LV winding.

<div style="border: 2px solid black; padding: 5px; width: fit-content;"> <p>i1-LV=0.00A i2-LV=0.00A</p> </div>	<p>This window shows secondary value of positive and negative sequence current in LV winding.</p>
<div style="border: 2px solid black; padding: 5px; width: fit-content;"> <p>ia-HV rms = 0.00 A ib-HV rms = 0.00 A</p> </div>	<p>This window shows secondary value of RMS current in phase A and Phase B of HV winding.</p>
<div style="border: 2px solid black; padding: 5px; width: fit-content;"> <p>ic-HV rms = 0.00 A ia-LV rms = 0.00 A</p> </div>	<p>This window shows secondary value of RMS current in phase C of HV winding and Phase A of LV winding.</p>
<div style="border: 2px solid black; padding: 5px; width: fit-content;"> <p>ib-LV rms = 0.00 A ic-LV rms = 0.00 A</p> </div>	<p>This window shows secondary value of RMS current in phase B and C of LV winding.</p>

2.3.5.2 View contents - Measurement 2 submenu

<div style="border: 2px solid black; padding: 5px; width: fit-content;"> <p>MEASUREMENTS</p> </div>	<p>Menu to view contents of Measurement 1, Measurement 2 and Measurement 3 submenu.</p>
<div style="border: 2px solid black; padding: 5px; width: fit-content;"> <p>Measurement 1</p> </div>	<p>Submenu to view measured and derived currents for HV and LV side winding.</p>
<div style="border: 2px solid black; padding: 5px; width: fit-content;"> <p>Measurement 2</p> </div>	<p>Submenu to view Bias and Differential currents, Thermal state and Breaker operating time and counter.</p>
<div style="border: 2px solid black; padding: 5px; width: fit-content;"> <p>ia-BIAS=0.00pu ia-DIFF=0.00pu</p> </div>	<p>This window shows secondary value of Bias and Differential current in Phase A</p>
<div style="border: 2px solid black; padding: 5px; width: fit-content;"> <p>ib-BIAS=0.00pu ib-DIFF=0.00pu</p> </div>	<p>This window shows secondary value of Bias and Differential current in Phase B</p>
<div style="border: 2px solid black; padding: 5px; width: fit-content;"> <p>ic-BIAS=0.00pu ic-DIFF=0.00pu</p> </div>	<p>This window shows secondary value of Bias and Differential current in Phase C</p>

<p>Th State 0%</p>	<p>This window shows Thermal state of the protected equipment.</p>
<p>BOT–HV=0ms BOC–HV=0</p>	<p>This window shows HV Breaker operating time and counter</p>
<p>BOT–LV=0ms BOC–LV=0</p>	<p>This window shows LV Breaker operating time and counter</p>

2.3.5.3 View contents - Measurement 3 submenu

<p>MEASUREMENTS</p>	<p>Menu to view contents of Measurement 1, Measurement 2 and Measurement 3 submenu.</p>
<p>Measurement 1</p>	<p>Submenu to view measured and derived currents for HV and LV side winding.</p>
<p>Measurement 2</p>	<p>Submenu to view Bias and Differential currents, Thermal state and Breaker operating time and counter.</p>
<p>Measurement 3</p>	<p>Submenu to view High and Low impedance REF current</p>
<p>Iref HV LoZ BIAS =0.00pu</p>	<p>This window shows low impedance Bias current in HV</p>
<p>Iref HV LoZ DIFF =0.00pu</p>	<p>This window shows low impedance Differential current in HV</p>
<p>Iref HV LoZ BIAS =0.00pu</p>	<p>This window shows low impedance Bias current in LV</p>

<p>Iref HV LoZ DIFF =0.00pu</p>	<p>This window shows low impedance Differential current in LV</p>
<p>Iref HV=0.00A Iref LV=0.00A</p>	<p>This window shows high impedance REF current in HV and LV</p>

2.3.6 CB Control menu

2.3.6.1 View/edit settings (if all settings are disabled)

<p>CB CONTROL</p>	<p>Password protected window for “CB CONTROL – HV CB CONTROL & LV CB CONTROL” settings i.e. TCS Alarm, TCS Timer, CB Open S’vision (Enabled / Disabled), CB Open Time, CB Open Alarm (Enabled / Disabled), CB Open Oper, CB Control By, Close Pulse Time, Open Pulse Time .</p>
<p>HV CB CONTROL</p>	<p>Read only setting</p>
<p>TCS Alarm NO</p>	<p>Editable setting By using the (+ / ▲) or (- / ▼) key, HV TCS Alarm can be set as Yes / No.</p>
<p>CB Open S’vision Disabled</p>	<p>Editable setting By using the (+ / ▲) or (- / ▼) key, HV CB Open Supervision can be Enabled or Disabled.</p>
<p>CB Open Alarm Disabled</p>	<p>Editable setting By using the (+ / ▲) or (- / ▼) key, HV CB Open Alarm can be Enabled or Disabled.</p>
<p>CB Control by Disabled</p>	<p>Editable setting By using the (+ / ▲) or (- / ▼) key, HV CB Control By can be set as Disabled / Local / Remote / Local + Remote.</p>
<p>LV CB CONTROL</p>	<p>Read only setting</p>
<p>TCS Alarm NO</p>	<p>Editable setting By using the (+ / ▲) or (- / ▼) key, LV TCS Alarm can be set as Yes / No.</p>

<p align="center">CB Open S'vision Disabled</p>	<p>Editable setting By using the (+ / ▲) or (- / ▼) key, LV CB Open Supervision can be Enabled or Disabled.</p>
<p align="center">CB Open Alarm Disabled</p>	<p>Editable setting By using the (+ / ▲) or (- / ▼) key, LV CB Open Alarm can be Enabled or Disabled.</p>
<p align="center">CB Control by Disabled</p>	<p>Editable Setting By using the (+ / ▲) or (- / ▼) key, LV CB Control By can be set as Disabled / Local / Remote / Local + Remote.</p>

2.3.6.2 View/edit settings (if all settings are enabled)

<p align="center">CB CONTROL</p>	<p>Password protected window for “CB CONTROL – HV CB CONTROL & LV CB CONTROL” settings i.e. TCS Alarm, TCS Timer, CB Open S'vision (Enabled / Disabled), CB Open Time, CB Open Alarm (Enabled / Disabled), CB Open Oper, CB Control By, Close Pulse Time and Open Pulse Time .</p>
<p align="center">HV CB CONTROL</p>	<p>Read only setting</p>
<p align="center">TCS Alarm YES</p>	<p>Editable setting By using the (+ / ▲) or (- / ▼) key, HV TCS Alarm can be set as Yes / No.</p>
<p align="center">TCS Timer 0.05 S</p>	<p>Editable setting By using the (+ / ▲) or (- / ▼) key, HV TCS Timer can be set. The setting range is from 0.1s to 10.00s in steps of 10ms.</p>
<p align="center">CB Open S'vision Enabled</p>	<p>Editable setting By using the (+ / ▲) or (- / ▼) key, HV CB Open Supervision can be Enabled or Disabled.</p>
<p align="center">CB Open Time 0.30S</p>	<p>Editable setting By using the (+ / ▲) or (- / ▼) key, HV CB Open Time can be set. The setting range is from 50ms to 1.0s in steps of 10ms</p>
<p align="center">CB Open Alarm Enabled</p>	<p>Editable setting By using the (+ / ▲) or (- / ▼) key, HV CB Open Alarm can be Enabled or Disabled.</p>

<p>CB Open Oper 2000</p>	<p>Editable setting By using the (+ / ▲) or (- / ▼) key, HV CB Open operations can be set. The setting range is from 1 to 30000 in steps of 1.</p>
<p>CB Control by Local + Remote</p>	<p>Editable setting By using the (+ / ▲) or (- / ▼) key, HV CB Control By can be set as Disabled / Local / Remote / Local + Remote.</p>
<p>Close Pulse Time 0.50S</p>	<p>Editable setting By using the (+ / ▲) or (- / ▼) key, the desired HV Close Pulse Time can be set. The setting range is from 0.1s to 50s in steps of 0.01s</p>
<p>Open Pulse Time 0.50S</p>	<p>Editable setting By using the (+ / ▲) or (- / ▼) key, the desired HV Open Pulse Time can be set. The setting range is from 0.1s to 50s in steps of 0.01s</p>
<p>LV CB CONTROL</p>	<p>Read only setting</p> <p><i>Note: All settings same as HV CB Control submenu</i></p>

2.3.7 Date and Time menu

2.3.7.1 Edit settings (if the settings are disabled)

<p>DATE AND TIME</p>	<p>Password protected window for “DATE AND TIME” settings : Local Time Enable, Local Time Offset, DST Enable, DST Offset, DST Start, DST Start Day, DST Start Month, DST Start minutes, DST End, DST End Day, DST End Month, DST End minutes, RP Time Zone, SET Hours, SET Minutes, SET Seconds, SET Date, SET Month and SET Year.</p>
-----------------------------	---

<p>Tm: 17:21:50</p> <p>Dt : 06/06/15 Sat</p>	<p>Read-only</p> <p>This window shows the set Date & Time</p>
<p>Local Time Enable</p> <p>Disabled</p>	<p>Editable setting</p> <p>By using the (+ / ▲) or (- / ▼) key, Local Time Enable can be set as Disabled / Fixed / Flexible.</p>
<p>DST Enable</p> <p>Disabled</p>	<p>Editable setting</p> <p>By using the (+ / ▲) or (- / ▼) key, DST Enable can be set as Enabled/Disabled.</p>
<p>RP Time Zone</p> <p>Local</p>	<p>Editable setting</p> <p>By using the (+ / ▲) or (- / ▼) key, RP Time Zone can be set as Local / UTC</p>
<p>SET Hours</p> <p>16</p>	<p>Editable setting</p> <p>By using the (+ / ▲) or (- / ▼) key, SET Hours can be set. The setting range is from 0 to 23 in steps of 1.</p>
<p>SET Minutes</p> <p>1</p>	<p>Editable setting</p> <p>By using the (+ / ▲) or (- / ▼) key, SET Minutes can be set. The setting range is from 0 to 59 in steps of 1.</p>
<p>SET Seconds</p> <p>11</p>	<p>Editable setting</p> <p>By using the (+ / ▲) or (- / ▼) key, SET Seconds can be set. The setting range is from 0 to 59 in steps of 1.</p>
<p>SET Date</p> <p>23</p>	<p>Editable setting</p> <p>By using (+ / ▲) or (- / ▼) key, SET Date can be set. The setting range is from 1 to 31 in steps of 1.</p>
<p>SET Month</p> <p>6</p>	<p>Editable setting</p> <p>By using the (+ / ▲) or (- / ▼) key, SET Month can be set. The setting range is from 1 to 12 in steps of 1.</p>
<p>SET Year</p> <p>15</p>	<p>Editable setting</p> <p>By using the (+ / ▲) or (- / ▼) key, SET Year can be set. The setting range is from 0 to 99 in steps of 1.</p>

2.3.7.2 Edit settings (if the settings are enabled)

<p style="text-align: center;">DATE AND TIME</p>	<p>Password protected window for “DATE AND TIME” settings : Local Time Enable, Local Time Offset, DST Enable, DST Offset, DST Start, DST Start Day, DST Start Month, DST Start minutes, DST End, DST End Day, DST End Month, DST End minutes, RP Time Zone, SET Hours, SET Minutes, SET Seconds, SET Date, SET Month and SET Year.</p>
<p style="text-align: center;">Tm: 17:21:50 Dt : 06/06/15 Sat</p>	<p>Read-only This window shows the set Date & Time</p>
<p style="text-align: center;">Local Time Enable Fixed</p>	<p>Editable setting By using the (+ / ▲) or (- / ▼) key, Local Time Enable can be set as Disabled / Fixed / Flexible.</p>
<p style="text-align: center;">Local Time Offset 0 Mins</p>	<p>Editable setting By using the (+ / ▲) or (- / ▼) key, Local Time Offset can be set. The setting range is from -720 mins to 720 mins in steps of 15 mins</p>
<p style="text-align: center;">DST Enable Enabled</p>	<p>Editable setting By using the (+ / ▲) or (- / ▼) key, DST Enable can be set as Enabled/Disabled.</p>
<p style="text-align: center;">DST Offset 60 Mins</p>	<p>Editable setting By using the (+ / ▲) or (- / ▼) key, DST Offset can be set as 30Mins / 60Mins.</p>
<p style="text-align: center;">DST Start Last</p>	<p>Editable setting By using the (+ / ▲) or the Minus / Down arrow key (- / ▼) key, DST Start can be set as First / Second/ Third / Fourth / Last.</p>
<p style="text-align: center;">DST Start Day Sunday</p>	<p>Editable setting By using the (+ / ▲) or (- / ▼) key, DST Start Day can be set from Sunday to Saturday.</p>
<p style="text-align: center;">DST Start Month March</p>	<p>Editable setting By using the (+ / ▲) or (- / ▼) key, DST Start Month can be set from January to December</p>
<p style="text-align: center;">DST Start Mins 60 Mins</p>	<p>Editable setting By using the (+ / ▲) or (- / ▼) key, DST Start minutes can be set. The setting range is from 0 to 1425 mins in steps of 15 mins.</p>

<p>DST End Last</p>	<p>Editable setting By using the (+ / ▲) or (- / ▼) key, DST End can be set as First / Second/ Third / Fourth / Last.</p>
<p>DST End Day Sunday</p>	<p>Editable setting By using the (+ / ▲) or (- / ▼) key, DST End Day can be set from Sunday to Saturday.</p>
<p>DST End Month October</p>	<p>Editable setting By using the (+ / ▲) or (- / ▼) key, DST End Month can be set from January to December</p>
<p>DST End Mins 60 Mins</p>	<p>Editable setting By using the (+ / ▲) or (- / ▼) key, DST End minutes can be set. The setting range is from 0 to 1425 mins in steps of 15 mins.</p>
<p>RP Time Zone Local</p>	<p>Editable setting By using the (+ / ▲) or (- / ▼) key, RP Time Zone can be set as Local / UTC</p>
<p>SET Hours 16</p>	<p>Editable setting By using the (+ / ▲) or (- / ▼) key, SET Hours can be set. The setting range is from 0 to 23 in steps of 1.</p>
<p>SET Minutes 1</p>	<p>Editable setting By using the (+ / ▲) or (- / ▼) key, SET Minutes can be set. The setting range is from 0 to 59 in steps of 1.</p>
<p>SET Seconds 11</p>	<p>Editable setting By using the (+ / ▲) or (- / ▼) key, SET Seconds can be set. The setting range is from 0 to 59 in steps of 1.</p>
<p>SET Date 23</p>	<p>Editable setting By using the (+ / ▲) or (- / ▼) key, SET Date can be set. The setting range is from 1 to 31 in steps of 1.</p>
<p>SET Month 6</p>	<p>Editable setting By using the (+ / ▲) or (- / ▼) key, SET Month can be set. The setting range is from 1 to 12 in steps of 1.</p>

<p style="text-align: center;">SET Year</p> <p style="text-align: center;">15</p>	<p>Editable setting</p> <p>By using the (+ / ▲) or (- / ▼) key, SET Year can be set. The setting range is from 0 to 99 in steps of 1.</p>
--	--

2.3.8 Configuration menu

2.3.8.1 View/edit settings

<p style="text-align: center;">CONFIGURATION</p>	<p>Password protected window for “CONFIGURATION” settings i.e. Restore Defaults, Active Settings, Copy From, Copy To, Setting Group 1 (Enabled/Disabled), Setting Group 2 (Enabled/Disabled), System Config (Enabled/Disabled), Diff Protection (Enabled/Disabled), HV REF (Enabled/Disabled), LV REF (Enabled/Disabled), HV Overcurrent (Enabled/Disabled), LV Overcurrent (Enabled/Disabled), HV Neg Sequence O/C (Enabled/Disabled), LV Neg Sequence O/C (Enabled/Disabled), HV Earth Fault (Enabled/Disabled), LV Earth Fault (Enabled/Disabled), Thermal Overload (Enabled/Disabled), HV CB Fail (Enabled/Disabled), LV CB Fail (Enabled/Disabled), Through Fault (Enabled/Disabled), Measure’t Setup and Setting Values.</p>
<p style="text-align: center;">Restore Defaults</p> <p style="text-align: center;">No Operation</p>	<p>Editable setting</p> <p>By using the (+ / ▲) or (- / ▼) key, Restore Defaults can be set as No Operation / All Settings / Setting Group 1 / Setting Group 2.</p>
<p style="text-align: center;">Active Settings</p> <p style="text-align: center;">Group 1</p>	<p>Editable setting</p> <p>By using the (+ / ▲) or (- / ▼) key, Active Setting can be set as Group 1 / Group 2.</p>
<p style="text-align: center;">Copy From</p> <p style="text-align: center;">Group 1</p>	<p>Editable setting</p> <p>By using the (+ / ▲) or (- / ▼) key, Copy From can be set as Group 1 / Group 2.</p>
<p style="text-align: center;">Copy To</p> <p style="text-align: center;">No Operation</p>	<p>Editable setting</p> <p>By using the (+ / ▲) or (- / ▼) key, Copy To can be set as No Operation / Group 1 / Group 2.</p>
<p style="text-align: center;">Setting Group 1</p> <p style="text-align: center;">Enabled</p>	<p>Editable setting</p> <p>By using the (+ / ▲) or (- / ▼) key, Setting Group 1 can be Enabled or Disabled.</p>
<p style="text-align: center;">Setting Group 2</p> <p style="text-align: center;">Disabled</p>	<p>Editable setting</p> <p>By using the (+ / ▲) or (- / ▼) key, Setting Group 2 can be Enabled or Disabled.</p>
<p style="text-align: center;">System Config</p> <p style="text-align: center;">Disabled</p>	<p>Editable setting</p> <p>By using the (+ / ▲) or (- / ▼) key, System Configuration can be Enabled or Disabled.</p>

<div style="border: 2px solid black; padding: 5px; text-align: center;"> Diff Protection Enabled </div>	Editable setting By using the (+ / ▲) or (- / ▼) key, Diff Protection can be Enabled or Disabled.
<div style="border: 2px solid black; padding: 5px; text-align: center;"> HV REF Enabled </div>	Editable setting By using the (+ / ▲) or (- / ▼) key, HV REF can be Enabled or Disabled.
<div style="border: 2px solid black; padding: 5px; text-align: center;"> LV REF Enabled </div>	Editable setting By using the (+ / ▲) or (- / ▼) key, LV REF can be Enabled or Disabled.
<div style="border: 2px solid black; padding: 5px; text-align: center;"> HV Overcurrent Enabled </div>	Editable setting By using the (+ / ▲) or (- / ▼) key, HV Overcurrent can be Enabled or Disabled.
<div style="border: 2px solid black; padding: 5px; text-align: center;"> LV Overcurrent Enabled </div>	Editable setting By using the (+ / ▲) or (- / ▼) key, LV Overcurrent can be Enabled or Disabled.
<div style="border: 2px solid black; padding: 5px; text-align: center;"> HV Neg Seq O/C Disabled </div>	Editable setting By using the (+ / ▲) or (- / ▼) key, HV Negative Seq O/C can be Enabled or Disabled.
<div style="border: 2px solid black; padding: 5px; text-align: center;"> LV Neg Seq O/C Disabled </div>	Editable setting By using the (+ / ▲) or (- / ▼) key, LV Negative Seq O/C can be Enabled or Disabled.
<div style="border: 2px solid black; padding: 5px; text-align: center;"> HV Earth Fault Enabled </div>	Editable setting By using the (+ / ▲) or (- / ▼) key, HV Earth Fault can be Enabled or Disabled.
<div style="border: 2px solid black; padding: 5px; text-align: center;"> LV Earth Fault Enabled </div>	Editable setting By using the (+ / ▲) or (- / ▼) key, LV Earth Fault can be Enabled or Disabled.
<div style="border: 2px solid black; padding: 5px; text-align: center;"> Thermal Overload Disabled </div>	Editable setting By using the (+ / ▲) or (- / ▼) key, Thermal Overload can be Enabled or Disabled.

<p>HV CB Fail Disabled</p>	<p>Editable setting By using the (+ / ▲) or (- / ▼) key, HV CB Fail can be Enabled or Disabled.</p>
<p>LV CB Fail Disabled</p>	<p>Editable setting By using the (+ / ▲) or (- / ▼) key, LV CB Fail can be Enabled or Disabled.</p>
<p>Through Fault Disabled</p>	<p>Editable setting By using the (+ / ▲) or (- / ▼) key, Through Fault can be Enabled or Disabled.</p>
<p>Measure't setup ABC</p>	<p>Editable setting By using the (+ / ▲) or (- / ▼) key, Measurement Setup can be set as ABC / RYB.</p>
<p>Setting Values Secondary</p>	<p>Editable setting By using the (+ / ▲) or (- / ▼) key, Setting values can be set as Primary / Secondary.</p>
<p>Measure't Values Secondary</p>	<p>Editable setting By using the (+ / ▲) or (- / ▼) key, Measure't values can be set as Primary / Secondary.</p>

2.3.9 Transformer Ratios menu

2.3.9.1 View/edit settings

<p>TRANS. RATIOS</p>	<p>Password protected window for “TRANS. RATIOS settings : HV Ph CT Prim'y, HV Ph CT Sec'y, LV Ph CT Prim'y, LV Ph CT Sec'y, HV REF CT Prim'y, HV REF CT Sec'y, LV REF CT Prim'y and LV REF CT Sec'y</p>
<p>HV Ph CT Prim'y 500 A</p>	<p>Editable setting By using the (+ / ▲) or (- / ▼) key, HV Phase CT Primary can be set. The setting range is from 1A to 30000A in steps of 1A.</p>
<p>HV Ph CT Sec'y 1 A</p>	<p>Read-only HV Phase CT Secondary rating can be viewed</p>
<p>LV Ph CT Prim'y 500 A</p>	<p>Editable setting By using the (+ / ▲) or (- / ▼) key, LV Phase CT Primary can be set. The setting range is from 1A to 30000A in steps of 1A.</p>

<p>LV Ph CT Sec'y 1 A</p>	<p>Read-only LV Phase CT Secondary rating can be viewed</p>
<p>HV REF CT Prim'y 100 A</p>	<p>Editable setting By using the (+ / ▲) or (- / ▼) key, HV REF CT Primary can be set. The setting range is from 1A to 30000A in steps of 1A.</p>
<p>HV REF CT Sec'y 1 A</p>	<p>Editable setting By using the (+ / ▲) or (- / ▼) key, HV REF CT Secondary can be set as 1A / 5A.</p>
<p>LV REF CT Prim'y 100 A</p>	<p>Editable setting By using the (+ / ▲) or (- / ▼) key, LV REF CT Primary can be set. The setting range is from 1A to 30000A in steps of 1A.</p>
<p>LV REF CT Sec'y 1 A</p>	<p>Editable setting By using the (+ / ▲) or (- / ▼) key, LV REF CT Secondary can be set as 1A / 5A.</p>

2.3.10 Record Control menu

2.3.10.1 View/edit settings

<p>RECORD CONTROL</p>	<p>Password protected window for "RECORD CONTROL" settings i.e. Clear Events (Yes/No), Clear Faults (Yes/No), Clear Dist Recs (Yes/No), Clear Maint (Yes/No), Reset HV CB data (Yes/No), Reset LV CB data (Yes/No) and Thermal Reset (Yes/No).</p>
<p>Clear Events No</p>	<p>Editable setting By using the (+ / ▲) or (- / ▼) key, Clear Event Records can be set as Yes / No. (set 'Yes' to clear event data stored in memory)</p>
<p>Clear Faults No</p>	<p>Editable setting By using the (+ / ▲) or (- / ▼) key, Clear Fault Records can be set as Yes / No. (set 'Yes' to clear Fault data stored in memory)</p>
<p>Clear Dist Recs No</p>	<p>Editable setting By using the (+ / ▲) or (- / ▼) key, Clear Disturbance Records can be set as Yes / No. (set 'Yes' to clear Disturbance Record data stored in memory)</p>
<p>Clear Maint No</p>	<p>Editable setting By using the (+ / ▲) or (- / ▼) key, Clear Maintenance Records can be set as Yes / No. (set 'Yes' to clear Maintenance Record data stored in memory)</p>

<div style="border: 2px solid black; padding: 5px; text-align: center;"> Reset HV CB Data No </div>	Editable setting By using the (+ / ▲) or (- / ▼) key, Reset HV CB Data can be set as Yes / No. (set 'Yes' to reset HV CB data)
<div style="border: 2px solid black; padding: 5px; text-align: center;"> Reset LV CB Data No </div>	Editable setting By using the (+ / ▲) or (- / ▼) key, Reset LV CB Data can be set as Yes / No. (set 'Yes' to reset HV CB data)
<div style="border: 2px solid black; padding: 5px; text-align: center;"> Thermal Reset No </div>	Editable setting By using the (+ / ▲) or (- / ▼) key, Thermal Reset can be set as Yes / No. (set 'Yes' to reset Thermal State to zero)

2.3.11 Communication menu

2.3.11.1 View/edit settings

<div style="border: 2px solid black; padding: 5px; text-align: center;"> COMMUNICATION </div>	Password protected window for “ COMMUNICATION ” settings : RP1 Address, RP1 Baud Rate, RP1 Parity and RP1 Timesync.
<div style="border: 2px solid black; padding: 5px; text-align: center;"> RP1 Address 1 </div>	Editable setting By using the (+ / ▲) or (- / ▼) key, the desired RP1 Address can be set. The setting range is from 1 to 247 in steps of 1.
<div style="border: 2px solid black; padding: 5px; text-align: center;"> RP1 Baud Rate 57600 </div>	Editable setting By using the (+ / ▲) or (- / ▼) key, the desired RP1 Baud Rate can be set as 9600 / 19200 / 38400 / 57600
<div style="border: 2px solid black; padding: 5px; text-align: center;"> RP1 Parity Even </div>	Editable setting By using the (+ / ▲) or (- / ▼) key, the desired RP1 Parity can be set as Even / Odd / None.
<div style="border: 2px solid black; padding: 5px; text-align: center;"> RP1 Timesync Disabled </div>	Editable setting By using the (+ / ▲) or (- / ▼) key, RP1 Timesync can be Enabled / Disabled

2.3.12 I/O Configuration menu

2.3.12.1 View/edit settings

<div style="border: 2px solid black; padding: 5px; text-align: center;"> IO CONFIGURATION </div>	Password protected window for “ IO CONFIGURATION ” settings: Relay, LED Green, LED Red, AND Logic and Opto I/P.

<div style="border: 2px solid black; padding: 5px; width: fit-content;"> Relay : 654321 Gen Strt 000000 </div>	<p>Editable setting By using the (+ / ▲) or (- / ▼) key, the output relay RL1 – RL6 can be set for desired function. ‘1’ corresponds to RL1, ‘2’ corresponds to RL2...‘6’ corresponds to RL6 Set the value ‘1’ for assigned / ‘0’ for not assigned under the numbers representing output relay.</p>
<div style="border: 2px solid black; padding: 5px; width: fit-content;"> LED G : 8765 Gen Strt 0000 </div>	<p>Editable setting By using the (+ / ▲) or (- / ▼) key, LED GREEN indication can be set for desired function. ‘5’ corresponds to LED L5, ‘6’ corresponds to LED L6...‘8’ corresponds to LED L8 Set the value ‘1’ for assigned / ‘0’ for not assigned under the numbers representing LED GREEN.</p>
<div style="border: 2px solid black; padding: 5px; width: fit-content;"> LED R : 8765 Gen Strt 0000 </div>	<p>Editable setting By using the (+ / ▲) or (- / ▼) key, LED RED indication can be set for desired function. ‘5’ corresponds to LED L5, ‘6’ corresponds to LED L6...‘8’ corresponds to LED L8 Set the value ‘1’ for assigned / ‘0’ for not assigned under the numbers representing LED RED.</p>
<div style="border: 2px solid black; padding: 5px; width: fit-content;"> AND Logic : DCBA Gen Strt 0000 </div>	<p>Editable setting By using the (+ / ▲) or (- / ▼) key, the AND Logic function (A,B,C,D) can be set for desired function. Set the value ‘1’ for assigned / ‘0’ for not assigned under the letters representing AND Logic function.</p>
<div style="border: 2px solid black; padding: 5px; width: fit-content;"> Opto I/P : 654321 Rem. Rst. 000000 </div>	<p>Editable setting By using the (+ / ▲) or (- / ▼) key, Opto inputs can be set for desired function. ‘1’ corresponds to Opto I/P S1, ‘2’ corresponds to Opto I/P S2...‘6’ corresponds to Opto I/P S6 Set the value ‘1’ for assigned / ‘0’ for not assigned under the numbers representing Opto I/Ps.</p>

2.3.12.2 List of the submenus for Relay Output, LEDs and AND Logic configuration

2.3.12.2.1 Relay output configuration

Relay outputs can be assigned by selecting any function available in the submenu. There are 6 numbers of output Relays identified as RL1 to RL6.

2.3.12.2.2 LED configuration for Green colour indication

LED G (Green) can be assigned by selecting any function available in the submenu. There are 4 numbers of programmable LEDs identified as L5 to L8.

2.3.12.2.3 LED configuration for Red colour indication

LED R (Red) can be assigned by selecting any function available in the submenu. There are 4 numbers of programmable LEDs identified as L5 to L8.

2.3.12.2.4 AND Logic

AND Logic can be assigned by selecting any function available in the submenus. There are 4 numbers of AND Logic with identifier as A, B, C & D.

The functions assigned to Relay, LED G, LED R and AND Logic are listed in **Chapter 8: Monitoring and Control**.

2.3.13 O/P Relay Configuration menu

2.3.13.1 View/edit settings

<p style="text-align: center;">O/P RELAY CONFIG</p>	<p>Password protected window for “O/P RELAY CONFIGURATION” settings: Contact HR/SR, O/P-1 Open Time, O/P-2 Open Time, O/P-3 Open Time, O/P-4 Open Time, O/P-5 Open Time and O/P-6 Open Time, LED G HR/SR, LED R HR/SR, ANDEQ A Op Time, ANDEQ Rst Time, ANDEQ B Op Time, ANDEQ B Rst Time, ANDEQ C Op Time, ANDEQ C Rst Time, ANDEQ D Op Time and ANDEQ D Rst Time.</p>
<p style="text-align: center;">Contact HR/SR 000000</p>	<p>Editable setting By using the (+ / ▲) or (- / ▼) key, the desired Contact HR/SR can be set as '1'=HR / '0'=SR.</p>
<p style="text-align: center;">O/P-1 Open Time 0.05 S</p>	<p>Editable setting By using the (+ / ▲) or (- / ▼) key, the desired O/P-1 Open Time can be set. The setting range is from 0 to 1s in steps of 0.01s</p>
<p style="text-align: center;">O/P-2 Open Time 0.05 S</p>	<p>Editable setting By using the (+ / ▲) or (- / ▼) key, the desired O/P-2 Open Time can be set. The setting range is from 0 to 1s in steps of 0.01s</p>
<p style="text-align: center;">O/P-3 Open Time 0.05 S</p>	<p>Editable setting By using the (+ / ▲) or (- / ▼) key, the desired O/P-3 Open Time can be set. The setting range is from 0 to 1s in steps of 0.01s</p>
<p style="text-align: center;">O/P-4 Open Time 0.05 S</p>	<p>Editable setting By using the (+ / ▲) or (- / ▼) key, the desired O/P-4 Open Time can be set. The setting range is from 0 to 1s in steps of 0.01s</p>
<p style="text-align: center;">O/P-5 Open Time 0.05 S</p>	<p>Editable setting By using the (+ / ▲) or (- / ▼) key, the desired O/P-5 Open Time can be set. The setting range is from 0 to 1s in steps of 0.01s</p>
<p style="text-align: center;">O/P-6 Open Time 0.05 S</p>	<p>Editable setting By using the (+ / ▲) or (- / ▼) key, the desired O/P-6 Open Time can be set. The setting range is from 0 to 1s in steps of 0.01s</p>

<div style="border: 2px solid black; padding: 5px; text-align: center;"> LED G HR/SR 0000 </div>	Editable setting By using the (+ / ▲) or (- / ▼) key, the desired function for LED GREEN can be set as HR/SR ('1'=HR /'0'=SR)
<div style="border: 2px solid black; padding: 5px; text-align: center;"> LED R HR/SR 0000 </div>	Editable setting By using the (+ / ▲) or (- / ▼) key, the desired function for LED RED can be set as HR/SR ('1'=HR /'0'=SR)
<div style="border: 2px solid black; padding: 5px; text-align: center;"> ANDEQ A Op Time 1 S </div>	Editable setting By using the (+ / ▲) or (- / ▼) key, the desired AND Equation A Operation Time can be set. The setting range is from 1 to 3600s in steps of 1s.
<div style="border: 2px solid black; padding: 5px; text-align: center;"> ANDEQ A Rst Time 1 S </div>	Editable setting By using the (+ / ▲) or (- / ▼) key, the desired AND Equation A Reset Time can be set. The setting range is from 1 to 3600s in steps of 1s.
<div style="border: 2px solid black; padding: 5px; text-align: center;"> ANDEQ B Op Time 1 S </div>	Editable setting By using the (+ / ▲) or (- / ▼) key, the desired AND Equation B Operation Time can be set. The setting range is from 1 to 3600s in steps of 1s..
<div style="border: 2px solid black; padding: 5px; text-align: center;"> ANDEQ B Rst Time 1 S </div>	Editable setting By using the (+ / ▲) or (- / ▼) key, the desired AND Equation B Reset Time can be set. The setting range is from 1 to 3600s in steps of 1s.
<div style="border: 2px solid black; padding: 5px; text-align: center;"> ANDEQ C Op Time 1 S </div>	Editable setting By using the (+ / ▲) or (- / ▼) key, the desired AND Equation C Operation Time can be set. The setting range is from 1 to 3600s in steps of 1s..
<div style="border: 2px solid black; padding: 5px; text-align: center;"> ANDEQ C Rst Time 1 S </div>	Editable setting By using the (+ / ▲) or (- / ▼) key, the desired AND Equation C Reset Time can be set. The setting range is from 1 to 3600s in steps of 1s.
<div style="border: 2px solid black; padding: 5px; text-align: center;"> ANDEQ D Op Time 1 S </div>	Editable setting By using the (+ / ▲) or (- / ▼) key, the desired AND Equation D Operation Time can be set. The setting range is from 1 to 3600s in steps of 1s.
<div style="border: 2px solid black; padding: 5px; text-align: center;"> ANDEQ D Rst Time 1 S </div>	Editable setting By using the (+ / ▲) or (- / ▼) key, the desired AND Equation D Reset Time can be set. The setting range is from 1 to 3600s in steps of 1s.

2.3.14 Disturbance Record menu

2.3.14.1 View/edit settings

<div style="border: 2px solid black; padding: 5px; text-align: center;"> DISTURBANCE REC </div>	Password protected window for “ Disturbance Record ” settings: Trigger Position
<div style="border: 2px solid black; padding: 5px; text-align: center;"> Trigger Position 50% </div>	Editable setting By using the (+ / ▲) or (- / ▼) key, the desired Trigger Position can be set. The setting range is from 10% to 90% in steps of 1.

2.3.15 Commissioning Test menu

2.3.15.1 View/edit settings

<div style="border: 2px solid black; padding: 5px; text-align: center;"> COMMISSION. TEST </div>	Password protected window for “ Commissioning Test ” settings: Test Mode, Test Pattern, Contact Test and Test LEDs.
<div style="border: 2px solid black; padding: 5px; text-align: center;"> Test Mode Disabled </div>	Editable setting By using the (+ / ▲) or (- / ▼) key, Test Mode be set as Disabled/Test Mode/Contacts Blocked.
<div style="border: 2px solid black; padding: 5px; text-align: center;"> Test Pattern 000000 </div>	Editable setting By using the (+ / ▲) or (- / ▼) key, Test Pattern can be set. Setting ‘1’ means that output relay contact will be tested when the Contact Test cell is set to Apply Test. Setting ‘0’ means that output relay contact will not be tested when the Contact Test cell is set to Apply Test. Eg: Setting 100010 will operate RL6 & RL2 during Contact test
<div style="border: 2px solid black; padding: 5px; text-align: center;"> Contact Test No Operation </div>	Editable setting By using the (+ / ▲) or (- / ▼) key, Contact Test can be set for No Operation / Apply Test / Remove Test
<div style="border: 2px solid black; padding: 5px; text-align: center;"> Test LEDs No Operation </div>	Editable setting By using the (+ / ▲) or (- / ▼) key, Test LEDs can be set for No Operation / Apply Test.

2.3.16 Group 1 menu

2.3.16.1 Edit settings

<div style="border: 2px solid black; padding: 5px; text-align: center;"> GROUP 1 </div>	Password protected window for “ GROUP 1 ” settings i.e. SYSTEM CONFIG, DIFF PROTECTION, REF PROTECTION, OVERCURRENT, NEG SEQUENCE O/C, EARTH FAULT, THERMAL OVERLOAD, CB FAIL and THROUGH FAULT. <i>Note: Group 1 settings will be seen only when it is enabled in Configuration menu.</i>
--	--

<p style="text-align: center;">SYSTEM CONFIG</p>	<p>Password protected window for System Configuration i.e. HV Connection, HV Grounding, HV Nominal Range, HV Nominal , Trafo Rating, LV Vector Group, LV Connection, LV Grounding, LV Nominal Range, LV Nominal, LV Rating, HV Match Factor, LV Match Factor, HV Iref, LV Iref, IH2 HV Prot'n (IH2 HV Set & I>lift 2H HV), IH2 LV Prot'n (IH2 LV Set & I>lift 2H LV)</p>
<p style="text-align: center;">DIFF PROTECTION</p>	<p>Password protected window for Differential Protection i.e. DIFF PROTECTION (Disabled/ Enabled → Is1, K1, Is2 & K2), IH2 Diff Block (Disabled /Enabled → IH2 Diff Set & Cross Blocking), IH5 Diff Block (Disabled /Enabled → IH5 Diff Set), tDiff, Is-HS1 and Is-HS2.</p>
<p style="text-align: center;">REF PROTECTION</p>	<p>Password protected window for REF Protection (HV and LV) i.e. HighZ REF (IREF Is1), LowZ REF (Is1 Set, Is2 Set, IREF K1, IREF K2, tREF), IH2 REF Block (IH2 REF Set)</p>
<p style="text-align: center;">OVERCURRENT</p>	<p>Password protected window for Overcurrent (HV and LV) i.e. I>1 Function, I>2 Function and I>3 Function. The functions can be set as Disabled / DT / IDMT.</p>
<p style="text-align: center;">NEG SEQUENCE O/C</p>	<p>Password protected window for Negative Sequence O/C (HV and LV) i.e. I2>1 Function, I2>2 Function and I2>3 Function. The functions can be set as Disabled / DT / IDMT.</p>
<p style="text-align: center;">EARTH FAULT</p>	<p>Password protected window for Earth Fault (HV and LV) i.e. IN>1 Function, IN>2 Function and IN>3 Function. The functions can be set as Disabled / DT / IDMT.</p>
<p style="text-align: center;">THERMAL OVERLOAD</p>	<p>Password protected window for Thermal Overload i.e. Characteristic (Disabled/Single), Thermal Trip, Thermal Alarm, Time Constant 1 and K.</p>
<p style="text-align: center;">CB FAIL</p>	<p>Password protected window for CB FAIL (HV and LV) i.e. CB Fail Timer, CB Reset, I<, and Remove I> Start.</p>
<p style="text-align: center;">THROUGH FAULT</p>	<p>Password protected window for Through Fault monitoring i.e. Through Fault (Enabled/Disabled), Monitored Input and TF I> Trigger.</p>

2.3.16.2 Group1 –System Configuration submenu

2.3.16.2.1 Edit settings (if 2nd harmonic is enabled)

<div style="border: 2px solid black; padding: 5px; text-align: center;">GROUP 1</div>	<p>Password protected window for “GROUP 1” settings i.e. SYSTEM CONFIG, DIFF PROTECTION, REF PROTECTION, OVERCURRENT, NEG SEQUENCE O/C, EARTH FAULT, THERMAL OVERLOAD, CB FAIL and THROUGH FAULT.</p> <p><i>Note: Group1 settings will be seen only when it is enabled in Configuration menu.</i></p>
<div style="border: 2px solid black; padding: 5px; text-align: center;">SYSTEM CONFIG</div>	<p>Password protected window for System Configuration i.e. HV Connection, HV Grounding, HV Nominal Range, HV Nominal , Trafo Rating, LV Vector Group, LV Connection, LV Grounding, LV Nominal Range, LV Nominal, LV Rating, HV Match Factor, LV Match Factor, HV Iref, LV Iref, IH2 HV Prot'n (IH2 HV Set & I>lift 2H HV), IH2 LV Prot'n (IH2 LV Set & I>lift 2H LV)</p>
<div style="border: 2px solid black; padding: 5px; text-align: center;">HV Connection Y-Wye</div>	<p>Editable setting By using the (+ / ▲) or (- / ▼) key, HV Connection type can be selected. i.e. Y-Wye / D-Delta.</p>
<div style="border: 2px solid black; padding: 5px; text-align: center;">HV Grounding Grounded</div>	<p>Editable setting By using the (+ / ▲) or (- / ▼) key, HV Grounding type can be selected. i.e. Grounded / Ungrounded</p>
<div style="border: 2px solid black; padding: 5px; text-align: center;">HV Nominal Range kV</div>	<p>Editable setting By using the (+ / ▲) or (- / ▼) key, the desired HV Nominal Range can be selected. i.e. V / kV</p>
<div style="border: 2px solid black; padding: 5px; text-align: center;">HV Nominal 11.0 kV</div>	<p>Editable setting By using the (+ / ▲) or (- / ▼) key, the desired HV Nominal can be set. The setting range is from 1.0 kV to 1000.0 kV in steps of 0.1kV</p>
<div style="border: 2px solid black; padding: 5px; text-align: center;">Trafo Rating 10.0 MVA</div>	<p>Editable setting By using the (+ / ▲) or (- / ▼) key, the desired Transformer Rating can be set. The setting range is 0.1 MVA to 3000 MVA in steps of 0.1 MVA</p>
<div style="border: 2px solid black; padding: 5px; text-align: center;">LV Vector Group 0</div>	<p>Editable setting By using the (+ / ▲) or (- / ▼) key, the desired LV Vector Group can be set. The setting range is 0 to 11 in steps of 1.</p>
<div style="border: 2px solid black; padding: 5px; text-align: center;">LV Connection Y-Wye</div>	<p>Editable setting By using the (+ / ▲) or (- / ▼) key, the desired LV Connection can be selected. i.e. Y-Wye / D-Delta.</p>

<div style="border: 2px solid black; padding: 5px; text-align: center;"> LV Grounding Grounded </div>	Editable setting By using the (+ / ▲) or (- / ▼) key, the desired LV Grounding can be selected. i.e. Grounded / Ungrounded
<div style="border: 2px solid black; padding: 5px; text-align: center;"> LV Nominal Range kV </div>	Editable setting By using the (+ / ▲) or (- / ▼) key, the desired LV Nominal Range can be selected. i.e. V / kV
<div style="border: 2px solid black; padding: 5px; text-align: center;"> LV Nominal 11.0 kV </div>	Editable setting By using the (+ / ▲) or (- / ▼) key, the desired LV Nominal can be set. The setting range is 1.0 kV to 1000.0 kV in steps of 0.1kV
<div style="border: 2px solid black; padding: 5px; text-align: center;"> HV Match Factor 1.526 </div>	Read-only HV Matching Factor value displayed
<div style="border: 2px solid black; padding: 5px; text-align: center;"> LV Match Factor 2.892 </div>	Read-only setting LV Matching Factor value displayed
<div style="border: 2px solid black; padding: 5px; text-align: center;"> HV Iref 0.6556 </div>	Read-only HV Iref value displayed
<div style="border: 2px solid black; padding: 5px; text-align: center;"> LV Iref 0.6345 </div>	Read-only setting LV Iref value displayed
<div style="border: 2px solid black; padding: 5px; text-align: center;"> IH2 HV Prot'n Enabled </div>	Editable setting By using the (+ / ▲) or (- / ▼) key, the IH2 HV Prot'n can be Enabled / Disabled.
<div style="border: 2px solid black; padding: 5px; text-align: center;"> IH2 HV Set 20 % </div>	Editable setting By using the (+ / ▲) or (- / ▼) key, the desired value for IH2 HV Set can be set. The setting range is 5% to 70% in steps of 1%.
<div style="border: 2px solid black; padding: 5px; text-align: center;"> I>lift 2H HV 10.00 A </div>	Editable setting By using the (+ / ▲) or (- / ▼) key, the desired value of I>lift 2H HV can be set. The setting range is 4.00 to 32.00 In in steps of 0.01 In.

<div style="border: 2px solid black; padding: 5px; text-align: center;"> IH2 LV Prot'n Enabled </div>	Editable setting By using the (+ / ▲) or (- / ▼) key, IH2 LV Prot'n can be Enabled / Disabled.
<div style="border: 2px solid black; padding: 5px; text-align: center;"> IH2 LV Set 20 % </div>	Editable setting By using the (+ / ▲) or (- / ▼) key, the desired value for IH2 LV Set can be set. The setting range is 5% to 70% in steps of 1%.
<div style="border: 2px solid black; padding: 5px; text-align: center;"> I>lift 2H LV 10.00 A </div>	Editable setting By using (+ / ▲) or (- / ▼) key the desired value for I>lift 2H LV can be set. The setting range is 4.00 to 32.00 In in steps of 0.01 In.

2.3.16.3 Group1 – Differential Protection submenu

2.3.16.3.1 Edit settings (if DIFF Protection is disabled)

<div style="border: 2px solid black; padding: 5px; text-align: center;"> GROUP 1 </div>	Password protected window for “ GROUP 1 ” settings i.e. SYSTEM CONFIG, DIFF PROTECTION, REF PROTECTION, OVERCURRENT, NEG SEQUENCE O/C, EARTH FAULT, THERMAL OVERLOAD, CB FAIL and THROUGH FAULT. <i>Note: Group1 settings will be seen only when it is enabled in Configuration menu.</i>
<div style="border: 2px solid black; padding: 5px; text-align: center;"> DIFF PROTECTION </div>	Password protected window for Differential Protection i.e. DIFF PROTECTION (Disabled/ Enabled → Is1, K1, Is2 & K2), IH2 Diff Block (Disabled /Enabled → IH2 Diff Set & Cross Blocking), IH5 Diff Block (Disabled /Enabled → IH5 Diff Set), tDiff, Is-HS1 and Is-HS2.
<div style="border: 2px solid black; padding: 5px; text-align: center;"> DIFF PROTECTION Disabled </div>	Editable setting By using the (+ / ▲) or (- / ▼) key, DIFF PROTECTION is Disabled.

2.3.16.3.2 Edit settings (if DIFF PROTECTION, IH2 and IH5 Diff Block are enabled)

<div style="border: 2px solid black; padding: 5px; text-align: center;"> GROUP 1 </div>	Password protected window for “ GROUP 1 ” settings i.e. SYSTEM CONFIG, DIFF PROTECTION, REF PROTECTION, OVERCURRENT, NEG SEQUENCE O/C, EARTH FAULT, THERMAL OVERLOAD, CB FAIL and THROUGH FAULT. <i>Note: Group1 settings will be seen only when it is enabled in Configuration menu.</i>
<div style="border: 2px solid black; padding: 5px; text-align: center;"> DIFF PROTECTION </div>	Password protected window for Differential Protection i.e. DIFF PROTECTION (Disabled/ Enabled → Is1, K1, Is2 & K2), IH2 Diff Block (Disabled /Enabled → IH2 Diff Set & Cross Blocking), IH5 Diff Block (Disabled /Enabled → IH5 Diff Set), tDiff, Is-HS1 and Is-HS2.
<div style="border: 2px solid black; padding: 5px; text-align: center;"> DIFF PROTECTION Enabled </div>	Editable setting By using the (+ / ▲) or (- / ▼) key, DIFF FUNCTION is Enabled.

<p>Is1 0.2 pu</p>	<p>Editable setting By using the (+ / ▲) or (- / ▼) key, the desired value of Is1 can be set. The setting range is from 0.1pu to 2.5pu in steps of 0.01 pu.</p>
<p>K1 30 %</p>	<p>Editable setting By using the (+ / ▲) or (- / ▼) key, the desired value of K1 can be set. The setting range is from 0% to 150% in steps of 1%</p>
<p>Is2 1 pu</p>	<p>Editable setting By using the (+ / ▲) or (- / ▼) key, the desired value of Is2 can be set. The setting range is from 0.1 pu to 10 pu in steps of 0.1 pu.</p>
<p>K2 80 %</p>	<p>Editable setting By using the (+ / ▲) or (- / ▼) key, the desired value of K2 can be set. The setting range is from 15% to 150% in steps of 1%.</p>
<p>IH2 Diff Block Enabled</p>	<p>Editable setting By using the (+ / ▲) or (- / ▼) key, IH2 Diff Block can be Enabled/Disabled</p>
<p>IH2 Diff Set 20 %</p>	<p>Editable setting By using the (+ / ▲) or (- / ▼) key, the desired IH2 Diff Setting can be done. The setting range is from 5% to 70% in steps of 1%</p>
<p>Cross Blocking Enabled</p>	<p>Editable setting By using the (+ / ▲) or (- / ▼) key, Cross Blocking can be Disabled/Enabled</p>
<p>IH5 Diff Block Enabled</p>	<p>Editable setting By using the (+ / ▲) or (- / ▼) key, IH5 Diff Block can be Enabled/Disabled</p>
<p>IH5 Diff Set 20 %</p>	<p>Editable setting By using the (+ / ▲) or (- / ▼) key, the desired value of IH5 Diff Set can be set. The setting range is from 5% to 70% in steps of 1%</p>
<p>tDiff 10.00 S</p>	<p>Editable setting By using the (+ / ▲) or (- / ▼) key, the desired value of tDiff can be set. The setting range is from 0s to 10s in steps of 0.01s</p>

<div style="border: 2px solid black; padding: 5px; width: fit-content;"> <p>Is-HS1 10.0 pu</p> </div>	<p>Editable setting By using the (+ / ▲) or (- / ▼) key, the desired value of Is-HS1 can be set. The setting range is from 0.5pu to 30pu in steps of 0.1pu</p>
<div style="border: 2px solid black; padding: 5px; width: fit-content;"> <p>Is-HS2 10.0 pu</p> </div>	<p>Editable setting By using the (+ / ▲) or (- / ▼) key, the desired value of Is-HS2 can be set. The setting range is from 0.5pu to 30pu in steps of 0.1pu</p>

2.3.16.4 Group1 – REF Protection submenu

2.3.16.4.1 Edit settings (if HV REF and LV REF are disabled)

<div style="border: 2px solid black; padding: 5px; width: fit-content;"> <p>GROUP 1</p> </div>	<p>Password protected window for “GROUP 1” settings i.e. SYSTEM CONFIG, DIFF PROTECTION, REF PROTECTION, OVERCURRENT, NEG SEQUENCE O/C, EARTH FAULT, THERMAL OVERLOAD, CB FAIL and THROUGH FAULT. <i>Note: Group1 settings will be seen only when it is enabled in Configuration menu.</i></p>
<div style="border: 2px solid black; padding: 5px; width: fit-content;"> <p>REF PROTECTION</p> </div>	<p>Password protected window for REF Protection (HV and LV) i.e. HighZ REF (IREF Is1), LowZ REF (Is1 Set, Is2 Set, IREF K1, IREF K2, tREF), IH2 REF Block (IH2 REF Set)</p>
<div style="border: 2px solid black; padding: 5px; width: fit-content;"> <p>HV REF</p> </div>	<p>Read-only This window shows the HV REF setting</p>
<div style="border: 2px solid black; padding: 5px; width: fit-content;"> <p>REF Status Disabled</p> </div>	<p>Editable setting By using the (+ / ▲) or (- / ▼) key, HV REF Status can be selected as Disabled / HighZ REF / LowZ REF <i>Note : Window shows HV REF Status selected as Disabled</i></p>
<div style="border: 2px solid black; padding: 5px; width: fit-content;"> <p>LV REF</p> </div>	<p>Read-only This window shows the LV REF setting</p>
<div style="border: 2px solid black; padding: 5px; width: fit-content;"> <p>REF Status Disabled</p> </div>	<p>Editable setting By using the (+ / ▲) or (- / ▼) key, LV REF Status can be selected as Disabled / HighZ REF / LowZ REF <i>Note : Window shows LV REF Status selected as Disabled</i></p>

2.3.16.4.2 Edit settings (if HV REF selected as LowZ REF / HighZ REF)

<div style="border: 2px solid black; padding: 5px; width: fit-content;"> <p>GROUP 1</p> </div>	<p>Password protected window for “GROUP 1” settings i.e. SYSTEM CONFIG, DIFF PROTECTION, REF PROTECTION, OVERCURRENT, NEG SEQUENCE O/C, EARTH FAULT, THERMAL OVERLOAD, CB FAIL and THROUGH FAULT. <i>Note: Group1 settings will be seen only when it is enabled in Configuration menu.</i></p>
---	---

REF PROTECTION	Password protected window for REF Protection (HV and LV) i.e. HighZ REF(IREF Is1), LowZ REF (Is1 Set, Is2 Set, IREF K1, IREF K2, tREF), IH2 REF Block (IH2 REF Set)
HV REF	Read-only This window shows the HV REF setting
Settings applicable for LowZ REF (if enabled)	
REF Status LowZ REF	Editable setting By using the (+ / ▲) or (- / ▼) key, HV REF Status selected as LowZ REF
Is1 Set 0.05 pu	Editable setting By using the (+ / ▲) or (- / ▼) key, the desired value of Is1 Setting can be set. The setting range is from 0.05 to 1 in steps of 0.01 pu
Is2 Set 0.1 pu	Editable setting By using the (+ / ▲) or (- / ▼) key, the desired value of Is2 Setting can be set. The setting range is from 0.1 to 10 in steps of 0.1 pu
IREF K1 0 %	Editable setting By using the (+ / ▲) or (- / ▼) key, the desired value of REF K1 can be set. The setting range is from 0% to 150% in steps of 1%
IREF K2 150 %	Editable setting By using the (+ / ▲) or (- / ▼) key, the desired value of REF K2 can be set. The setting range is from 015% to 150% in steps of 1%
tREF 0 S	Editable setting By using the (+ / ▲) or (- / ▼) key, the desired value of tREF can be set. The setting range is from 0s to 10s in steps of 0.01s
IH2 REF Block Enabled	Editable setting By using the (+ / ▲) or (- / ▼) key, IH2 REF Block can be Disabled/Enabled Note : Window shows IH2 REF Block selected as Enabled

<p>IH2 REF Set 20 %</p>	<p>Editable setting By using the (+ / ▲) or (- / ▼) key, the desired value of IH2 REF Set can be set. The setting range is from From 5% to 70% in steps of 1%</p>
Settings applicable for HighZ REF (if enabled)	
<p>REF Status HighZ REF</p>	<p>Editable setting By using the (+ / ▲) or (- / ▼) key, HV REF Status HV can be selected as HighZ REF</p>
<p>IREF Is 0.01 pu</p>	<p>Editable setting By using the (+ / ▲) or (- / ▼) key, the desired value of IREF Is can be set. The setting range is from 0.01 to 1 in steps of 0.01</p>
<p>IH2 REF Block Enabled</p>	<p>Editable setting By using the (+ / ▲) or (- / ▼) key, IH2 REF Block can be Disabled/Enabled Note : Window shows IH2 REF Block selected as Enabled</p>
<p>IH2 REF Set 20 %</p>	<p>Editable setting By using the (+ / ▲) or (- / ▼) key, the desired value of IH2 REF Set can be set. The setting range is from From 5% to 70% in steps of 1%</p>

Note: Settings will be visible only when the respective functions are enabled.

LV REF Protection settings are similar to HV REF Protection settings.

2.3.16.5 Group1 – Overcurrent submenu

2.3.16.5.1 Edit settings - HV Overcurrent (if I>1 Function is selected for IEC curve)

<p>GROUP 1</p>	<p>Password protected window for “GROUP 1” settings i.e. SYSTEM CONFIG, DIFF PROTECTION, REF PROTECTION, OVERCURRENT, NEG SEQUENCE O/C, EARTH FAULT, THERMAL OVERLOAD, CB FAIL and THROUGH FAULT. <i>Note: Group1 settings will be seen only when it is enabled in Configuration menu.</i></p>
<p>OVERCURRENT</p>	<p>Password protected window for Overcurrent (HV and LV) i.e. I>1 Function, I>2 Function and I>3 Function. The functions can be set as Disabled / DT / IDMT.</p>
<p>HV OVERCURRENT</p>	<p>Password protected window for HV Overcurrent i.e. I>1 Function, I>2 Function and I>3 Function. The functions can be set as Disabled / DT / IEC S Inverse / S Inverse (1.3Sec) / IEC V Inverse / IEC E Inverse/ UK LT Inverse / IEEE M Inverse / IEEE V Inverse / IEEE E Inverse / US Inverse / US ST Inverse.</p>

<div style="border: 2px solid black; padding: 5px; width: fit-content;"> <p>I>1 Function IEC S Inverse</p> </div>	<p>Editable setting By using the (+ / ▲) or (- / ▼) key, I>1Function is set IEC S Inverse.</p>
<div style="border: 2px solid black; padding: 5px; width: fit-content;"> <p>I>1 Current Set 1.00 A</p> </div>	<p>Editable setting By using the (+ / ▲) or (- / ▼) key, I>1 Current Setting can be set. The setting range is from 0.05 to 4.00 In in steps of 0.01 In.</p>
<div style="border: 2px solid black; padding: 5px; width: fit-content;"> <p>I>1 TMS 1.000</p> </div>	<p>Editable setting By using (+ / ▲) or (- / ▼) key, I>1 TMS can be set. The setting range is from 0.025 to 1.200 in steps of 0.005.</p>
<div style="border: 2px solid black; padding: 5px; width: fit-content;"> <p>I>1 Reset Char DT</p> </div>	<p>Read-only setting I>1 Reset Char is fixed as DT (Definite Time).</p>
<div style="border: 2px solid black; padding: 5px; width: fit-content;"> <p>I>1 tRESET 0.01 S</p> </div>	<p>Editable setting By using the (+ / ▲) or (- / ▼) key, I>1 tRESET can be set. The setting range is from 0 to 100s in steps of 0.01s.</p>
<div style="border: 2px solid black; padding: 5px; width: fit-content;"> <p>I>1 2H Blocking Disabled</p> </div>	<p>Editable setting By using the (+ / ▲) or (- / ▼) key, I>12H Blocking function can set as Enabled / Disabled.</p>

2.3.16.5.2 Edit settings- HV Overcurrent (if I>1 Function is selected for IEEE / US curve)

<div style="border: 2px solid black; padding: 5px; width: fit-content;"> <p>GROUP 1</p> </div>	<p>Password protected window for “GROUP 1” settings i.e. SYSTEM CONFIG, DIFF PROTECTION, REF PROTECTION, OVERCURRENT, NEG SEQUENCE O/C, EARTH FAULT, THERMAL OVERLOAD, CB FAIL and THROUGH FAULT. <i>Note: Group1 settings will be seen only when it is enabled in Configuration menu.</i></p>
<div style="border: 2px solid black; padding: 5px; width: fit-content;"> <p>OVERCURRENT</p> </div>	<p>Password protected window for Overcurrent (HV and LV) i.e. I>1 Function, I>2 Function and I>3 Function. The functions can be set as Disabled / DT / IDMT.</p>
<div style="border: 2px solid black; padding: 5px; width: fit-content;"> <p>HV OVERCURRENT</p> </div>	<p>Password protected window for HV Overcurrent i.e. I>1 Function, I>2 Function and I>3 Function. The functions can be set as Disabled / DT / IEC S Inverse / S Inverse (1.3Sec) / IEC V Inverse / IEC E Inverse / UK LT Inverse / IEEE M Inverse / IEEE V Inverse / IEEE E Inverse / US Inverse / US ST Inverse.</p>

<p>I>1 Function IEEE M Inverse</p>	<p>Editable setting By using the (+ / ▲) or (- / ▼) key, I>1 Function is set as IEEE M Inverse.</p>
<p>I>1 Current Set 1.00 A</p>	<p>Editable setting By using the (+ / ▲) or (- / ▼) key, I>1 Current Setting can be set. The setting range is from 0.05 to 4 In in steps of 0.01 In.</p>
<p>I>1 Time Dial 1.00</p>	<p>Editable setting By using the (+ / ▲) or (- / ▼) key, I>1 Time Dial can be set. The setting range is from 00.01 to 100.00 in steps of 0.01.</p>
<p>I>1 Reset Char DT</p>	<p>Editable setting By using the (+ / ▲) or (- / ▼) key, I>1 Reset Char can be set as IDMT / DT (Definite Time).</p>
<p>I>1 tRESET 0.01 S</p>	<p>Editable setting By using the (+ / ▲) or (- / ▼) key, I>1 tRESET can be set. The setting range is from 0 to 100s in steps of 0.01s.</p>
<p>I>1 RTMS 1.000</p>	<p>Editable setting By using the (+ / ▲) or (- / ▼) key, I>1 RTMS can be set. The setting range is from 0.025 to 1.200 in steps of 0.005 Note: Above setting available if I>1 Reset Char is set as IDMT</p>
<p>I>1 2H Blocking Disabled</p>	<p>Editable setting By using the (+ / ▲) or (- / ▼) key, I>12H Blocking function can be Enabled / Disabled.</p>

2.3.16.5.3 Edit Settings - HV Overcurrent (if I>1 Function is selected for DT)

<p>GROUP 1</p>	<p>Password protected window for “GROUP 1” settings i.e. SYSTEM CONFIG, DIFF PROTECTION, REF PROTECTION, OVERCURRENT, NEG SEQUENCE O/C, EARTH FAULT, THERMAL OVERLOAD, CB FAIL and THROUGH FAULT. <i>Note: Group1 settings will be seen only when it is enabled in Configuration menu.</i></p>
<p>OVERCURRENT</p>	<p>Password protected window for Overcurrent (HV and LV) i.e. I>1 Function, I>2 Function and I>3 Function. The functions can be set as Disabled / DT / IDMT.</p>
<p>HV OVERCURRENT</p>	<p>Password protected window for HV Overcurrent i.e. I>1 Function, I>2 Function and I>3 Function. The functions can be set as Disabled / DT / IEC S Inverse / S Inverse (1.3Sec) / IEC V Inverse / IEC E Inverse / UK LT Inverse / IEEE M Inverse / IEEE V Inverse / IEEE E Inverse / US Inverse / US ST Inverse.</p>

<p>I>1 Function DT</p>	<p>Editable setting By using the (+ / ▲) or (- / ▼) key, I>1Function is set as DT.</p>
<p>I>1 Current Set 1.00 A</p>	<p>Editable setting By using the (+ / ▲) or (- / ▼) key, the desired I>1 Current Setting can be set. The setting range is from 0.05 to 35.0 In in steps of 0.01 In. Note: For I>3 Function. the setting range is from 1.0 - 35.0 In in steps of 0.01 In.</p>
<p>I>1 Time Delay 01.00 S</p>	<p>Editable setting By using the (+ / ▲) or (- / ▼) key, I>1 Time Delay can be set. The setting range is from 0 to 100s in steps of 0.01s.</p>
<p>I>1 Reset Char DT</p>	<p>Read-only I>1 Reset Char is fixed as DT (Definite Time).</p>
<p>I>1 tRESET 0.01 S</p>	<p>Editable setting By using the (+ / ▲) or (- / ▼) key, I>1 tRESET can be set. The setting range is from 0 to 100s in steps of 0.01s.</p>
<p>I>1 2H Blocking Disabled</p>	<p>Editable setting By using the (+ / ▲) or (- / ▼) key, I>1 2H Blocking function can be Enabled / Disabled.</p>

Note: Settings will be visible only when the respective functions are enabled.

The settings for I>2 Function and I>3 Function should be done in a similar manner as I>1 Function.

LV Overcurrent function settings are similar to HV Overcurrent function and can be set in similar manner.

2.3.16.6 Group1 – Negative Sequence Overcurrent submenu

2.3.16.6.1 Edit settings - HV Negative Sequence O/C (if I2>1 Function is selected for IEC curve)

<p>GROUP 1</p>	<p>Password protected window for “GROUP 1” settings i.e. SYSTEM CONFIG, DIFF PROTECTION, REF PROTECTION, OVERCURRENT, NEG SEQUENCE O/C, EARTH FAULT, THERMAL OVERLOAD, CB FAIL and THROUGH FAULT. <i>Note: Group1 settings will be seen only when it is enabled in Configuration menu.</i></p>
-----------------------	---

<p style="text-align: center;">NEG SEQUENCE O/C</p>	<p>Password protected window for NEG SEQUENCE O/C (HV and LV) settings : I2>1 Function, I2>2 Function and I2>3 Function can be set as Disabled / DT / IDMT</p>
<p style="text-align: center;">HV NEG SEQ O/C</p>	<p>Password protected window for HV NEG SEQ O/C settings : I2>1 Function, I2>2 Function and I2>3 Function can be set as Disabled / DT / IEC S Inverse / S Inverse (1.3Sec) / IEC V Inverse / IEC E Inverse / UK LT Inverse / IEEE M Inverse / IEEE V Inverse / IEEE E Inverse / US Inverse / US ST Inverse</p>
<p style="text-align: center;">I2>1 Function IEC S Inverse</p>	<p>Editable setting By using the (+ / ▲) or (- / ▼) key, I2>1 Function is set as IEC S Inverse.</p>
<p style="text-align: center;">I2>1 Current Set 1.00 A</p>	<p>Editable setting By using the (+ / ▲) or (- / ▼) key, I2>1 Current Setting can be done. The setting range is from 0.10 to 4.00 In in steps of 0.01.</p>
<p style="text-align: center;">I2>1 TMS 1.000</p>	<p>Editable setting By using the (+ / ▲) or (- / ▼) key, I2>1 TMS can be set. The setting range is from 0.025 to 1.200 in steps of 0.005.</p>
<p style="text-align: center;">I2>1 Reset Char DT</p>	<p>Read-only The I2>1 Reset Char is fixed as DT (Definite Time).</p>
<p style="text-align: center;">I2>1 tRESET 0.01 S</p>	<p>Editable setting By using the (+ / ▲) or (- / ▼) key, I2>1 tRESET can be set. The setting range is from 0 to 100s in steps of 0.01s.</p>
<p style="text-align: center;">I2>1 2HBlocking Disabled</p>	<p>Editable setting By using the (+ / ▲) or (- / ▼) key, I2>12HBlocking function can be Enabled / Disabled.</p>

2.3.16.6.2 Edit settings - HV Negative Sequence O/C (if I2>1 Function is selected for IEEE / US curve)

<p style="text-align: center;">GROUP 1</p>	<p>Password protected window for “GROUP 1” settings i.e. SYSTEM CONFIG, DIFF PROTECTION, REF PROTECTION, OVERCURRENT, NEG SEQUENCE O/C, EARTH FAULT, THERMAL OVERLOAD, CB FAIL and THROUGH FAULT.</p> <p><i>Note: Group1 settings will be seen only when it is enabled in Configuration menu.</i></p>
<p style="text-align: center;">NEG SEQUENCE O/C</p>	<p>Password protected window for NEG SEQUENCE O/C (HV and LV) settings : I2>1 Function, I2>2 Function and I2>3 Function can be set as Disabled / DT / IDMT</p>
<p style="text-align: center;">HV NEG SEQ O/C</p>	<p>Password protected window for HV NEG SEQ O/C settings : I2>1 Function, I2>2 Function and I2>3 Function can be set as Disabled / DT / IEC S Inverse / S Inverse (1.3Sec) / IEC V Inverse / IEC E Inverse / UK LT Inverse / IEEE M Inverse / IEEE V Inverse / IEEE E Inverse / US Inverse / US ST Inverse</p>
<p style="text-align: center;">I2>1 Function IEEE M Inverse</p>	<p>Editable setting By using the (+ / ▲) or (- / ▼) key, I2>1 Function is set as IEEE M Inverse.</p>
<p style="text-align: center;">I2>1 Current Set 1.00 A</p>	<p>Editable setting By using the (+ / ▲) or (- / ▼) key, I2>1 Current Setting can be set. The setting range is from 0.10 to 4.00 In in steps of 0.01 In.</p>
<p style="text-align: center;">I2>1 Time Dial 1.00</p>	<p>Editable setting By using the (+ / ▲) or (- / ▼) key, I2>1 Time Dial can be set. The setting range is from 0.01 to 100.00 in steps of 0.01.</p>
<p style="text-align: center;">I2>1 Reset Char DT</p>	<p>Editable setting By using the (+ / ▲) or (- / ▼) key, I2>1 Reset Char can be set as IDMT / DT.</p>
<p style="text-align: center;">I2>1 tRESET 0.01 S</p>	<p>Editable setting By using the (+ / ▲) or (- / ▼) key, I2>1 tRESET can be set. The setting range is from 0 to 100s in steps of 0.01s.</p>
<p style="text-align: center;">I2>1 RTMS 1.000</p>	<p>Editable setting By using the (+ / ▲) or (- / ▼) key, I2>1 RTMS can be set. The setting range is from 0.025 to 1.200 in steps of 0.005 Note: Above setting available if I2>1 Reset Char is set as IDMT</p>

<p>I2>1 2H Blocking Disabled</p>	<p>Editable setting By using the (+ / ▲) or (- / ▼) key, I2>12H Blocking function can be Enabled / Disabled.</p>
---	--

2.3.16.6.3 Edit settings (if I2>1 Function is selected for DT)

<p>GROUP 1</p>	<p>Password protected window for “GROUP 1” settings i.e. SYSTEM CONFIG, DIFF PROTECTION, REF PROTECTION, OVERCURRENT, NEG SEQUENCE O/C, EARTH FAULT, THERMAL OVERLOAD, CB FAIL and THROUGH FAULT. <i>Note: Group1 settings will be seen only when it is enabled in Configuration menu.</i></p>
<p>NEG SEQUENCE O/C</p>	<p>Password protected window for NEG SEQUENCE O/C (HV and LV) settings : I2>1 Function, I2>2 Function and I2>3 Function can be set as Disabled / DT / IDMT</p>
<p>HV NEG SEQ O/C</p>	<p>Password protected window for HV NEG SEQ O/C settings : I2>1 Function, I2>2 Function and I2>3 Function can be set as Disabled / DT / IEC S Inverse/ S Inverse (1.3Sec)/ IEC V Inverse/ IEC E Inverse/ UK LT Inverse /IEEE M Inverse/ IEEE V Inverse/ IEEE E Inverse /US Inverse /US ST Inverse</p>
<p>I2>1 Function DT</p>	<p>Editable setting By using the (+ / ▲) or (- / ▼) key, I2>1Function is set as DT (Definite Time).</p>
<p>I2>1 Current Set 1.00 A</p>	<p>Editable setting By using the (+ / ▲) or (- / ▼) key, I2>1 Current Setting can be set. The setting range is from 0.10 to 35.0 In in steps of 0.01 In. <i>Note: For I2>3 Function, the setting range is from 1.0 - 35.0 In in steps of 0.01 In</i></p>
<p>I2>1 Time Delay 1.00 S</p>	<p>Editable setting By using the (+ / ▲) or (- / ▼) key, I2>1 Time Delay can be set. The setting range is from 0 to 200s in steps of 0.01s.</p>
<p>I2>1 Reset Char DT</p>	<p>Read-only I2>1 Reset Char is fixed as DT (Definite Time).</p>
<p>I2>1 tRESET 0.01 S</p>	<p>Editable setting By using the (+ / ▲) or (- / ▼) key, I2>1 tRESET can be set. The setting range is from 0 to 100s in steps of 0.01s.</p>

<p>I2>1 2H Blocking Disabled</p>	<p>Editable setting By using the (+ / ▲) or (- / ▼) key, I2>12H Blocking function can be Enabled / Disabled.</p>
---	--

Note: Settings will be visible only when the respective functions are enabled.

The settings of I>2 Function and I>3 Function should be done in a similar manner as I>1 Function.

LV NEG SEQ Overcurrent function settings are similar to HV NEG SEQ Overcurrent function and can be set in similar manner.

2.3.16.7 Group 1 – Earth Fault submenu

2.3.16.7.1 Edit settings - HV Earth Fault (if IN>1 Function is selected for IEC curve)

<p>GROUP 1</p>	<p>Password protected window for “GROUP 1” settings i.e. SYSTEM CONFIG, DIFF PROTECTION, REF PROTECTION, OVERCURRENT, NEG SEQUENCE O/C, EARTH FAULT, THERMAL OVERLOAD, CB FAIL and THROUGH FAULT. <i>Note: Group1 settings will be seen only when it is enabled in Configuration menu.</i></p>
<p>EARTH FAULT</p>	<p>Password protected window for Earth Fault (HV and LV) i.e. IN>1 Function, IN>2 Function and IN>3 Function. The functions can be set as Disabled / DT / IEC S Inverse / S Inverse (1.3Sec) / IEC V Inverse / IEC E Inverse / UK LT Inverse / IEEE M Inverse / IEEE V Inverse / IEEE E Inverse / US Inverse / US ST Inverse</p>
<p>HV EARTH FAULT Measured</p>	<p>Editable setting By using the (+ / ▲) or (- / ▼) key, HV EARTH FAULT can be selected as Measured/Derived <i>Note : Window shows selection for Measured Earth Fault</i></p>
<p>IN>1 Function IEC S Inverse</p>	<p>Editable setting By using the (+ / ▲) or (- / ▼) key, IN>1Function is set as IEC S Inverse.</p>
<p>IN>1 Current Set 1.00 A</p>	<p>Editable setting By using the (+ / ▲) or (- / ▼) key, IN>1 Current Setting can be set. The setting range is from 0.05 to 4 In in steps of 0.01 In.</p>
<p>IN>1 TMS 1.000</p>	<p>Editable setting By using the (+ / ▲) or (- / ▼) key, IN>1 TMS can be set. The setting range is from 0.025 to 1.200 in steps of 0.005.</p>

<div style="border: 2px solid black; padding: 5px; text-align: center;"> IN>1 Reset Char DT </div>	Read-only IN>1 Reset Char is fixed as DT (Definite Time).
<div style="border: 2px solid black; padding: 5px; text-align: center;"> IN>1 tRESET 0.01 S </div>	Editable setting By using the (+ / ▲) or (- / ▼) key, IN>1 tRESET can be set. The setting range is from 0 to 100s in steps of 0.01s.
<div style="border: 2px solid black; padding: 5px; text-align: center;"> IN>1 2HBlocking Disabled </div>	Editable setting By using the (+ / ▲) or (- / ▼) key, IN>1 2HBlocking can be Enabled / Disabled.

2.3.16.7.2 Edit settings - HV Earth Fault (if IN>1 Function is selected for IEEE/US curve)

<div style="border: 2px solid black; padding: 5px; text-align: center;"> GROUP 1 </div>	Password protected window for “ GROUP 1 ” settings i.e. SYSTEM CONFIG, DIFF PROTECTION, REF PROTECTION, OVERCURRENT, NEG SEQUENCE O/C, EARTH FAULT, THERMAL OVERLOAD, CB FAIL and THROUGH FAULT. <i>Note: Group1 settings will be seen only when it is enabled in Configuration menu.</i>
<div style="border: 2px solid black; padding: 5px; text-align: center;"> EARTH FAULT </div>	Password protected window for Earth Fault (HV and LV) i.e. IN>1 Function, IN>2 Function and IN>3 Function. The functions can be set as Disabled / DT / IEC S Inverse / S Inverse (1.3Sec) / IEC V Inverse / IEC E Inverse / UK LT Inverse / IEEE M Inverse / IEEE V Inverse / IEEE E Inverse / US Inverse / US ST Inverse
<div style="border: 2px solid black; padding: 5px; text-align: center;"> HV EARTH FAULT Measured </div>	Editable setting By using the (+ / ▲) or (- / ▼) key, HV EARTH FAULT can be selected as Measured/Derived Note : Window shows selection for Measured Earth Fault
<div style="border: 2px solid black; padding: 5px; text-align: center;"> IN>1 Function IEEE M Inverse </div>	Editable setting By using the (+ / ▲) or (- / ▼) key, IN>1Function is set as IEEE M Inverse.
<div style="border: 2px solid black; padding: 5px; text-align: center;"> IN>1 Current Set 1.00 A </div>	Editable setting By using the (+ / ▲) or (- / ▼) key, IN>1 Current Setting can be set. The setting range is from 0.05 to 4 In in steps of 0.01 In.
<div style="border: 2px solid black; padding: 5px; text-align: center;"> IN>1 Time Dial 1.00 </div>	Editable setting By using the (+ / ▲) or (- / ▼) key, IN>1 Time Dial can be set. The setting range is from 0.01 to 100.00 in steps of 0.01.

<div style="border: 2px solid black; padding: 5px; text-align: center;"> IN>1 Reset Char DT </div>	Editable setting By using the (+ / ▲) or (- / ▼) key, IN>1 Reset Char can be set as IDMT / DT.
<div style="border: 2px solid black; padding: 5px; text-align: center;"> IN>1 tRESET 0.01 S </div>	Editable setting By using the (+ / ▲) or (- / ▼) key, IN>1 tRESET can be set. The setting range is from 0 to 100s in steps of 0.01s.
<div style="border: 2px solid black; padding: 5px; text-align: center;"> IN>1 RTMS 1.000 </div>	Editable setting By using the (+ / ▲) or (- / ▼) key, IN>1 RTMS can be set. The setting range is from 0.025 to 1.200 in steps of 0.005 Note: Above setting is available if IN>1 Reset Char is set as IDMT
<div style="border: 2px solid black; padding: 5px; text-align: center;"> IN>1 2HBlocking Disabled </div>	Editable setting By using the (+ / ▲) or (- / ▼) key, IN>1 2HBlocking function can be Enabled / Disabled.

2.3.16.7.3 Edit settings - HV Earth Fault (if IN>1 Function is selected for DT)

<div style="border: 2px solid black; padding: 5px; text-align: center;"> GROUP 1 </div>	Password protected window for “ GROUP 1 ” settings i.e. SYSTEM CONFIG, DIFF PROTECTION, REF PROTECTION, OVERCURRENT, NEG SEQUENCE O/C, EARTH FAULT, THERMAL OVERLOAD, CB FAIL and THROUGH FAULT. <i>Note: Group1 settings will be seen only when it is enabled and set under Active Settings in Configuration menu.</i>
<div style="border: 2px solid black; padding: 5px; text-align: center;"> EARTH FAULT </div>	Password protected window for Earth Fault (HV and LV) i.e. IN>1 Function, IN>2 Function and IN>3 Function. The functions can be set as Disabled / DT / IEC S Inverse / S Inverse (1.3Sec) / IEC V Inverse / IEC E Inverse / UK LT Inverse / IEEE M Inverse / IEEE V Inverse / IEEE E Inverse / US Inverse / US ST Inverse
<div style="border: 2px solid black; padding: 5px; text-align: center;"> HV EARTH FAULT Measured </div>	Editable setting By using the (+ / ▲) or (- / ▼) key, HV EARTH FAULT can be selected as Measured/Derived Note : Window shows selection for Measured Earth Fault
<div style="border: 2px solid black; padding: 5px; text-align: center;"> IN>1 Function DT </div>	Editable setting By using the (+ / ▲) or (- / ▼) key, IN1>1Function is set as DT.
<div style="border: 2px solid black; padding: 5px; text-align: center;"> IN>1 Current Set 1.00 A </div>	Editable setting By using the (+ / ▲) or (- / ▼) key, IN>1 Current Setting can be set. The setting range is from 0.05 to 35.0 In in steps of 0.01 In. <i>Note: For I>3 Function, the setting range is from 1.0 - 35.0In in steps of 0.01In.</i>

<p>IN>1 Time Delay 1.00 S</p>	<p>Editable setting By using the (+ / ▲) or (- / ▼) key, IN>1 Time Delay can be set. The setting range is from 0 to 200s in steps of 0.01s.</p>
<p>IN>1 Reset Char DT</p>	<p>Read-only IN>1 Reset Char is fixed as DT (Definite Time).</p>
<p>IN>1 tRESET 0.01 S</p>	<p>Editable setting By using the (+ / ▲) or (- / ▼) key, IN>1 tRESET can be set. The setting range is from 0 to 100s in steps of 0.01s.</p>
<p>IN>1 2HBlocking Disabled</p>	<p>Editable setting By using the (+ / ▲) or (- / ▼) key, IN>1 2HBlocking function can be Enabled / Disabled.</p>

Note: Settings will be visible only when the respective functions are enabled.

The settings of IN>2 Function and IN>3 Function to be done in similar manner as that of IN>1

LV Earth Fault function settings are similar to HV Earth Fault function and can be set in similar manner.

2.3.16.8 Group1 – Thermal Overload submenu

2.3.16.8.1 Edit settings (if Thermal overload Characteristic is disabled)

<p>GROUP 1</p>	<p>Password protected window for “GROUP 1” settings i.e. SYSTEM CONFIG, DIFF PROTECTION, REF PROTECTION, OVERCURRENT, NEG SEQUENCE O/C, EARTH FAULT, THERMAL OVERLOAD, CB FAIL and THROUGH FAULT. <i>Note: Group1 settings will be seen only when it is enabled and set under Active Settings in Configuration menu.</i></p>
<p>THERMAL OVERLOAD</p>	<p>Password protected window for Thermal Overload i.e. Characteristic (Disabled/Single), Thermal Trip, Thermal Alarm, Time Constant 1 and K.</p>
<p>THERMAL OVERLOAD HV</p>	<p>Editable setting By using the (+ / ▲) or (- / ▼) key, Thermal Overload can be set for HV/LV <i>Note: Widow shows selection for HV Thermal Overload</i></p>

<p>Characteristic Disabled</p>	<p>Editable setting By using the (+ / ▲) or (- / ▼) key, Characteristic is set as Disabled</p>
--	---

2.3.16.8.2 Edit Settings (if Thermal Overload Characteristic is set as Single)

<p>GROUP 1</p>	<p>Password protected window for “GROUP 1” settings i.e. SYSTEM CONFIG, DIFF PROTECTION, REF PROTECTION, OVERCURRENT, NEG SEQUENCE O/C, EARTH FAULT, THERMAL OVERLOAD, CB FAIL and THROUGH FAULT. <i>Note: Group1 settings will be seen only when it is enabled and set under Active Settings in Configuration menu.</i></p>
<p>THERMAL OVERLOAD</p>	<p>Password protected window for Thermal Overload i.e. Characteristic (Disabled/Single), Thermal Trip, Thermal Alarm, Time Constant 1 and K.</p>
<p>THERMAL OVERLOAD HV</p>	<p>Editable setting By using the (+ / ▲) or (- / ▼) key, Thermal Overload can be set for HV/LV <i>Note: Widow shows selection for HV Thermal Overload</i></p>
<p>Characteristic Single</p>	<p>Editable setting By using the (+ / ▲) or (- / ▼) key, Characteristic is set as Single</p>
<p>Thermal Trip 1.00 A</p>	<p>Editable setting By using the (+ / ▲) or (- / ▼) key, Thermal Trip can be set. The setting range is from 0.1 to 4.00 In in steps of 0.01 In.</p>
<p>Thermal Alarm 70%</p>	<p>Editable setting By using the (+ / ▲) or (- / ▼) key, Thermal Alarm can be set. The setting range is from 50% to 100% in steps of 1%.</p>
<p>Time Constant 1 10</p>	<p>Editable setting By using the (+ / ▲) or (- / ▼) key, Time Constant 1 can be set. The setting range is from 1 to 200 in steps of 1.</p>
<p>K 1.05</p>	<p>Editable setting By using the (+ / ▲) or (- / ▼) key, K Constant can be set. The setting range is from 1 to 1.5 in steps of 0.01.</p>

Note: The Thermal overload settings for LV side can be done in similar manner to Thermal overload HV settings.

2.3.16.9 Group 1 – CB Fail submenu

2.3.16.9.1 Edit settings - HV CB Fail

<div style="border: 2px solid black; padding: 5px; text-align: center;">GROUP 1</div>	Password protected window for “ GROUP 1 ” settings i.e. SYSTEM CONFIG, DIFF PROTECTION, REF PROTECTION, OVERCURRENT, NEG SEQUENCE O/C, EARTH FAULT, THERMAL OVERLOAD, CB FAIL and THROUGH FAULT. <i>Note: Group1 settings will be seen only when it is enabled and set under Active Settings in Configuration menu.</i>
<div style="border: 2px solid black; padding: 5px; text-align: center;">CB FAIL</div>	Password protected window for CB FAIL (HV and LV) settings i.e. CB Fail Timer, CB Reset, I<, and Remove I> Start.
<div style="border: 2px solid black; padding: 5px; text-align: center;">HV CB FAIL</div>	Password protected window for HV CB FAIL i.e. CB Fail Timer, CB Reset, I<, and Remove I> Start.
<div style="border: 2px solid black; padding: 5px; text-align: center;">CB Fail Timer 0.10 S</div>	Editable setting By using the (+ / ▲) or (- / ▼) key, CB Fail Timer can be set. The setting range is from 0 to 50s in steps of 0.01s.
<div style="border: 2px solid black; padding: 5px; text-align: center;">CBF Reset CB Open+ I<</div>	By using the (+ / ▲) or (- / ▼) key, CBF Reset can be set as 'CB Open + I<', 'Prot Reset + I<', 'CB Open' or 'I<'
<div style="border: 2px solid black; padding: 5px; text-align: center;">I< 1.00 A</div>	By using the (+ / ▲) or (- / ▼) key, I< can be set. The setting range is from 0.05 to 3.2 In in steps of 0.01In
<div style="border: 2px solid black; padding: 5px; text-align: center;">Remove I> Start Disabled</div>	Editable setting By using the (+ / ▲) or (- / ▼) key, Remove I> Start can be Enabled / Disabled

Note: The LV CB Fail settings can be done in similar manner to HV CB Fail settings.

2.3.16.10 Group 1 – Through Fault submenu

2.3.16.10.1 Edit settings - Through Fault settings (If function is enabled)

<div style="border: 2px solid black; padding: 5px; text-align: center;">GROUP 1</div>	Password protected window for “ GROUP 1 ” settings i.e. SYSTEM CONFIG, DIFF PROTECTION, REF PROTECTION, OVERCURRENT, NEG SEQUENCE O/C, EARTH FAULT, THERMAL OVERLOAD, CB FAIL and THROUGH FAULT. <i>Note: Group1 settings will be seen only when it is enabled in Configuration menu.</i>

<div style="border: 2px solid black; padding: 5px; text-align: center;"> THROUGH FAULT </div>	Password protected window for Through Fault monitoring i.e. Through Fault (Enabled/Disabled), Monitored Input and TF I> Trigger.
<div style="border: 2px solid black; padding: 5px; text-align: center;"> Through Fault Enabled </div>	Editable setting By using the (+ / ▲) or (- / ▼) key, Through Fault can be Enabled/Disabled. <i>Note: Window shows Through Fault function enabled.</i>
<div style="border: 2px solid black; padding: 5px; text-align: center;"> Monitored Input HV Current </div>	By using the (+ / ▲) or (- / ▼) key, the Monitored Input can be selected as HV Current / LV Current / Bias Current. <i>Note: Window shows HV Current selected.</i>
<div style="border: 2px solid black; padding: 5px; text-align: center;"> TF I> Trigger 3.85pu </div>	Editable setting By using (+ / ▲) or (- / ▼) key, the desired TF I> Trigger can be set. The setting range is from 0.08 to 20 pu step 0.01 pu

2.3.17 Group 2 menu

2.3.17.1 Edit settings

<div style="border: 2px solid black; padding: 5px; text-align: center;"> GROUP 2 </div>	Password protected window for “ GROUP 2 ” settings i.e. SYSTEM CONFIG, DIFF PROTECTION, REF PROTECTION, OVERCURRENT, NEG SEQUENCE O/C, EARTH FAULT, THERMAL OVERLOAD, CB FAIL and THROUGH FAULT. <i>Note: Group2 settings will be seen only when it is enabled and set under Active Settings in Configuration menu.</i>
<div style="border: 2px solid black; padding: 5px; text-align: center;"> SYSTEM CONFIG </div>	Password protected window for System Configuration i.e. HV Connection, HV Grounding, HV Nominal Range, HV Nominal, Trafo Rating, LV Vector Group, LV Connection, LV Grounding, LV Nominal Range, LV Nominal, LV Rating, HV Match Factor, LV Match Factor, HV Iref, LV Iref, IH2 HV Prot'n (IH2 HV Set & I>lift 2H HV), IH2 LV Prot'n (IH2 LV Set & I>lift 2H LV)
<div style="border: 2px solid black; padding: 5px; text-align: center;"> DIFF PROTECTION </div>	Password protected window for Differential Protection i.e. DIFF PROTECTION (Disabled/ Enabled → Is1, K1, Is2 & K2), IH2 Diff Block (Disabled /Enabled → IH2 Diff Set & Cross Blocking), IH5 Diff Block (Disabled /Enabled → IH5 Diff Set), tDiff, Is-HS1 and Is-HS2.
<div style="border: 2px solid black; padding: 5px; text-align: center;"> REF PROTECTION </div>	Password protected window for REF Protection (HV and LV) i.e. HighZ REF (IREF Is1), LowZ REF (Is1 Set, Is2 Set, IREF K1, IREF K2, tREF), IH2 REF Block (IH2 REF Set)
<div style="border: 2px solid black; padding: 5px; text-align: center;"> OVERCURRENT </div>	Password protected window for Overcurrent (HV and LV) i.e. I>1 Function, I>2 Function and I>3 Function. The functions can be set as Disabled / DT / IDMT.

NEG SEQUENCE O/C	Password protected window for Negative Sequence O/C (HV and LV) i.e. I2>1 Function, I2>2 Function and I2>3 Function. The functions can be set as Disabled / DT / IDMT.
EARTH FAULT	Password protected window for Earth Fault (HV and LV) i.e. IN1>1 Function, IN1>2 Function and IN1>3 Function. The functions can be set as Disabled / DT / IDMT.
THERMAL OVERLOAD	Password protected window for Thermal Overload i.e. Characteristic (Disabled/Single), Thermal Trip, Thermal Alarm, Time Constant 1 and K.
CB FAIL	Password protected window for CB FAIL (HV and LV) i.e. CB Fail Timer, CB Reset, I<, and Remove I> Start.
THROUGH FAULT	Password protected window for Through Fault monitoring i.e. Through Fault (Enabled/Disabled), Monitored Input and TF I> Trigger.

Note: The Group 2 settings for System Configuration, Diff Protection, REF Protection, Over Current, Negative Sequence O/C, Earth Fault, Thermal Overload, CB Fail and Through Fault settings are similar to Group 1.

2.4 Configuration flowcharts

2.4.1 Main menu

After the Power ON or when the relay is reset the following windows will be displayed, and the user can scroll through the main menu as below.

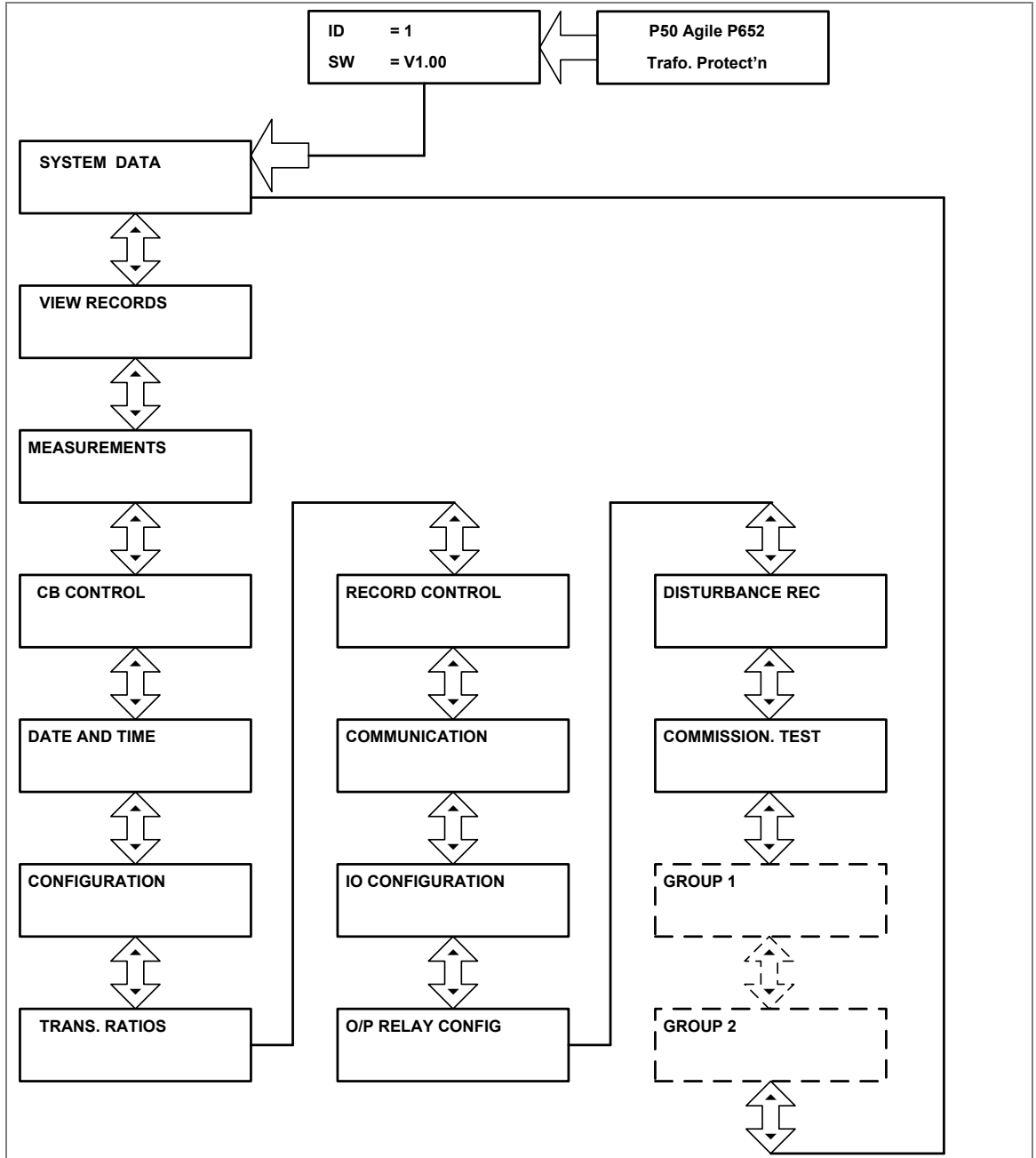

Note: Group 1 & Group 2 Setting will be seen only when it is enabled in Configuration menu.

2.4.2 View and Edit settings

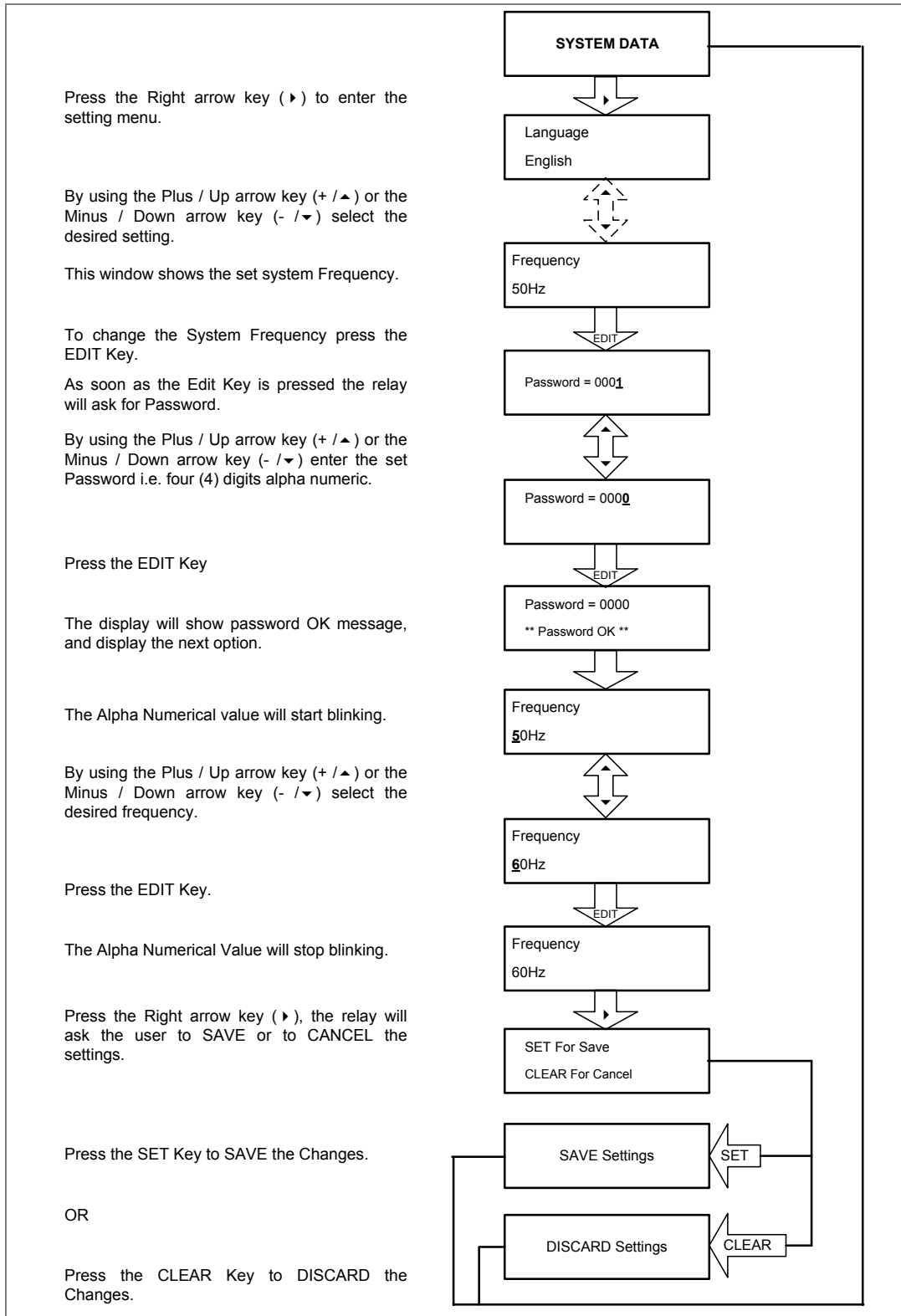

2.4.3 View System Data menu settings

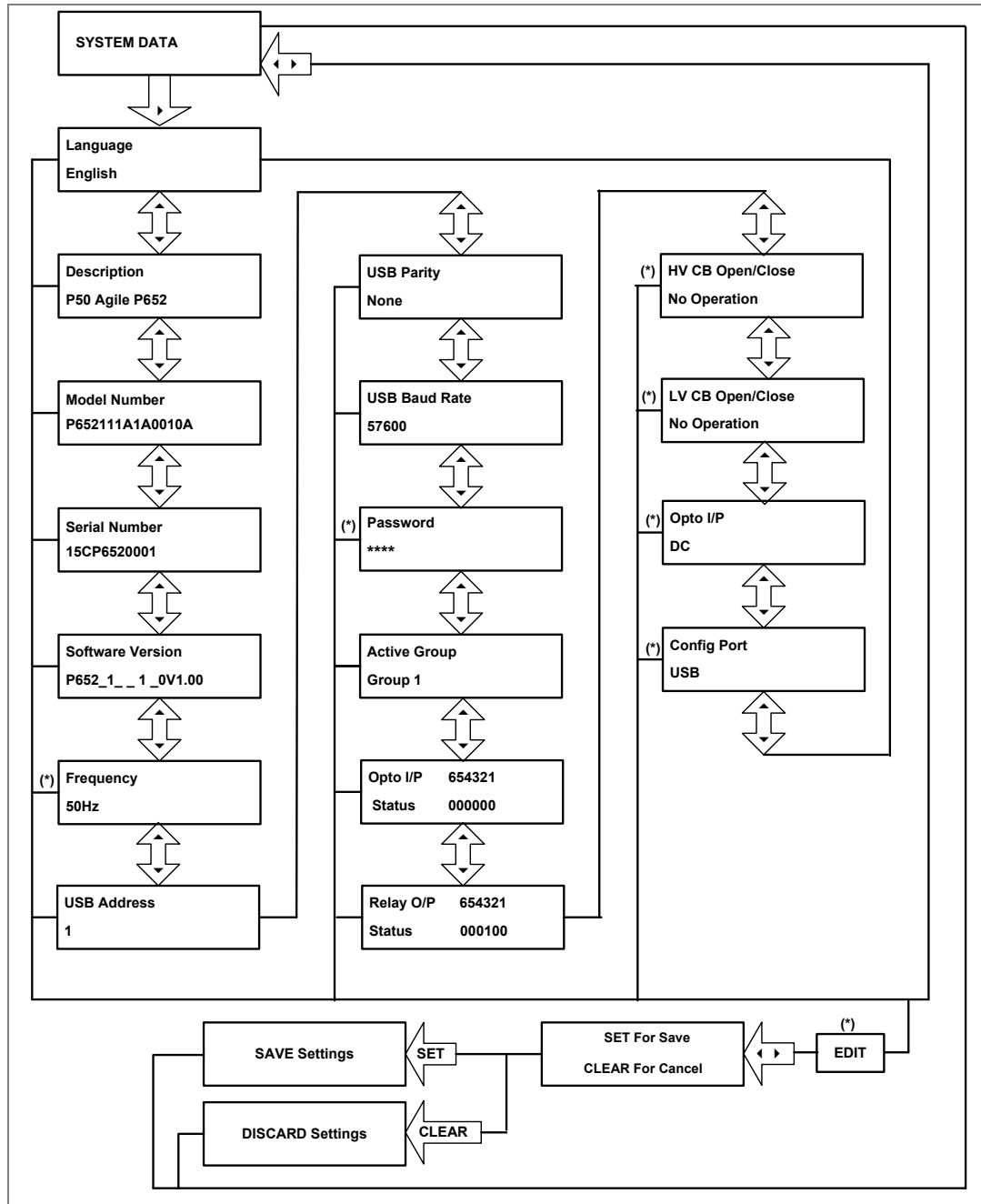

Note: (*) indicates **EDIT** key is used to modify settings. Refer to the View and Edit settings section.

2.4.4 View Records menu

2.4.4.1 View content

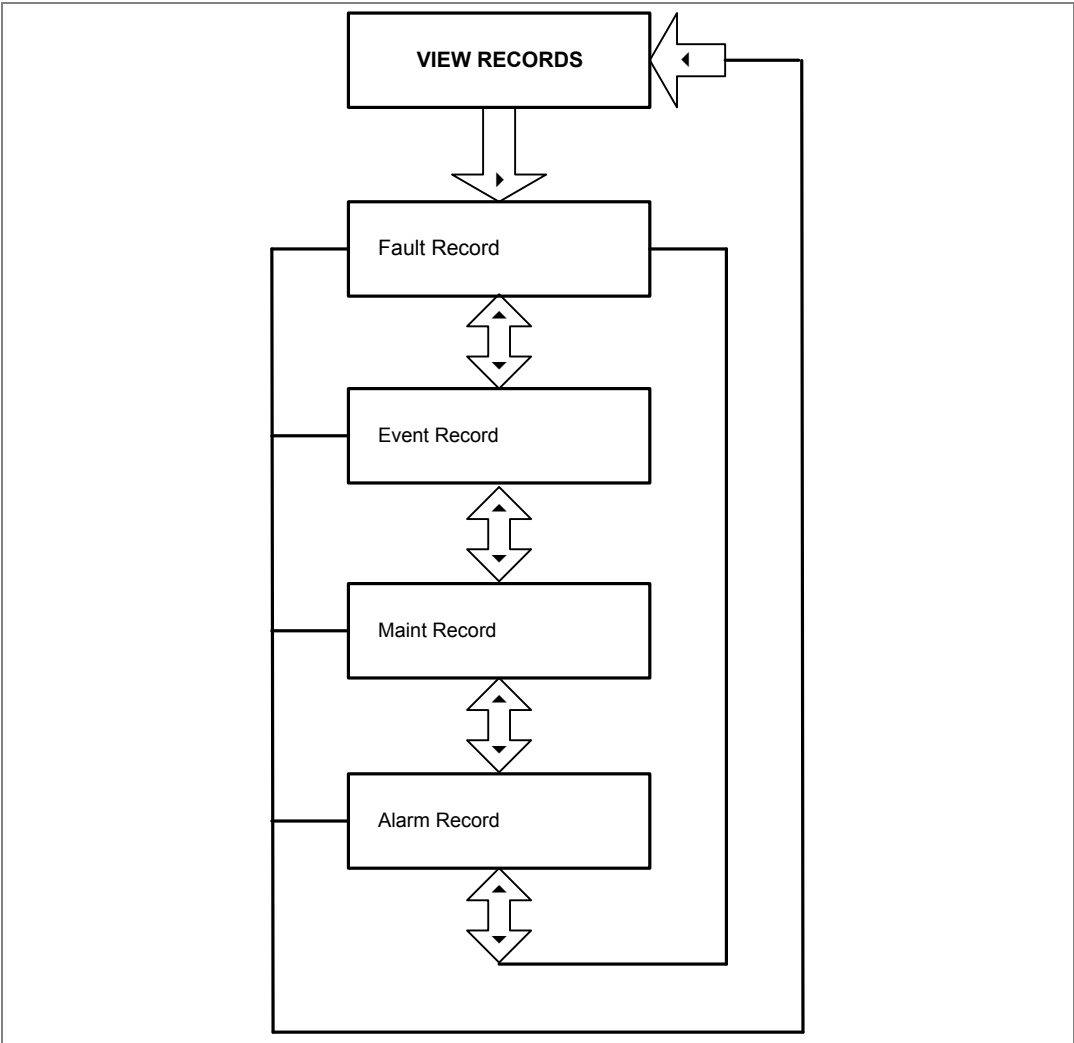

2.4.4.2 View Fault Records

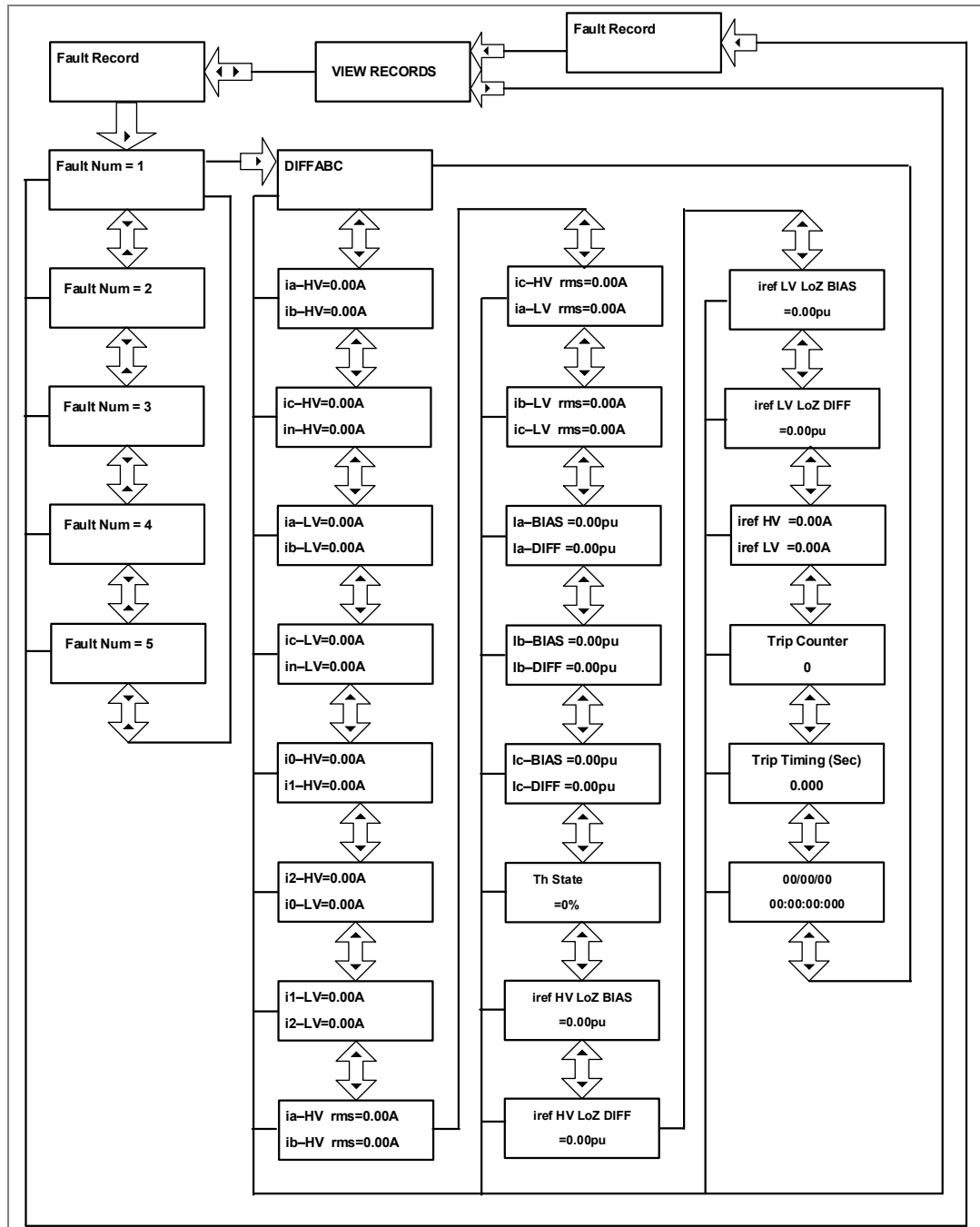

2.4.4.3 View Event Records

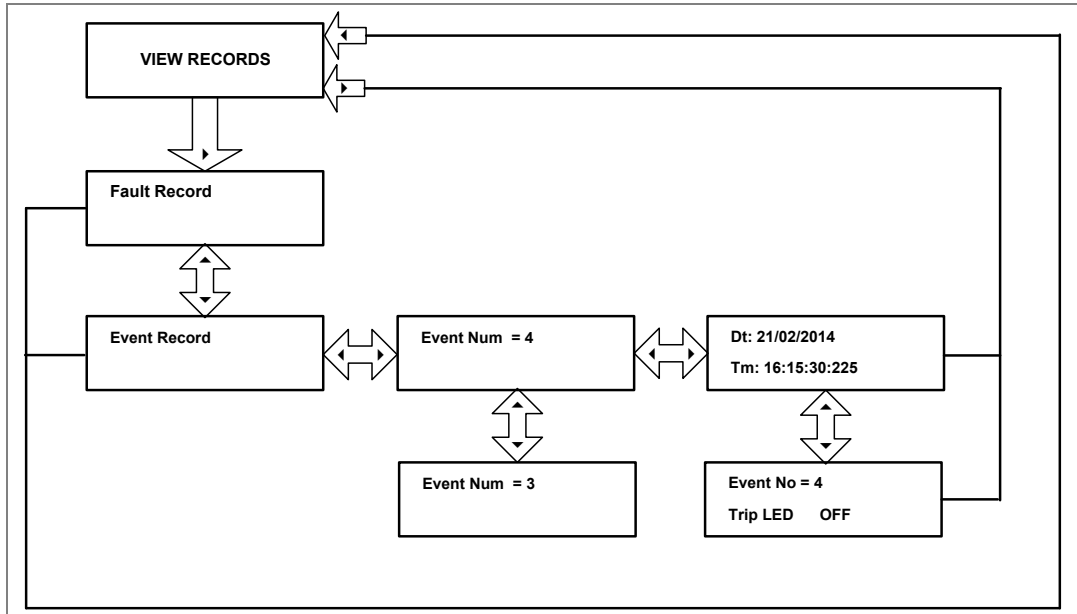

2.4.4.4 View Maintenance Records

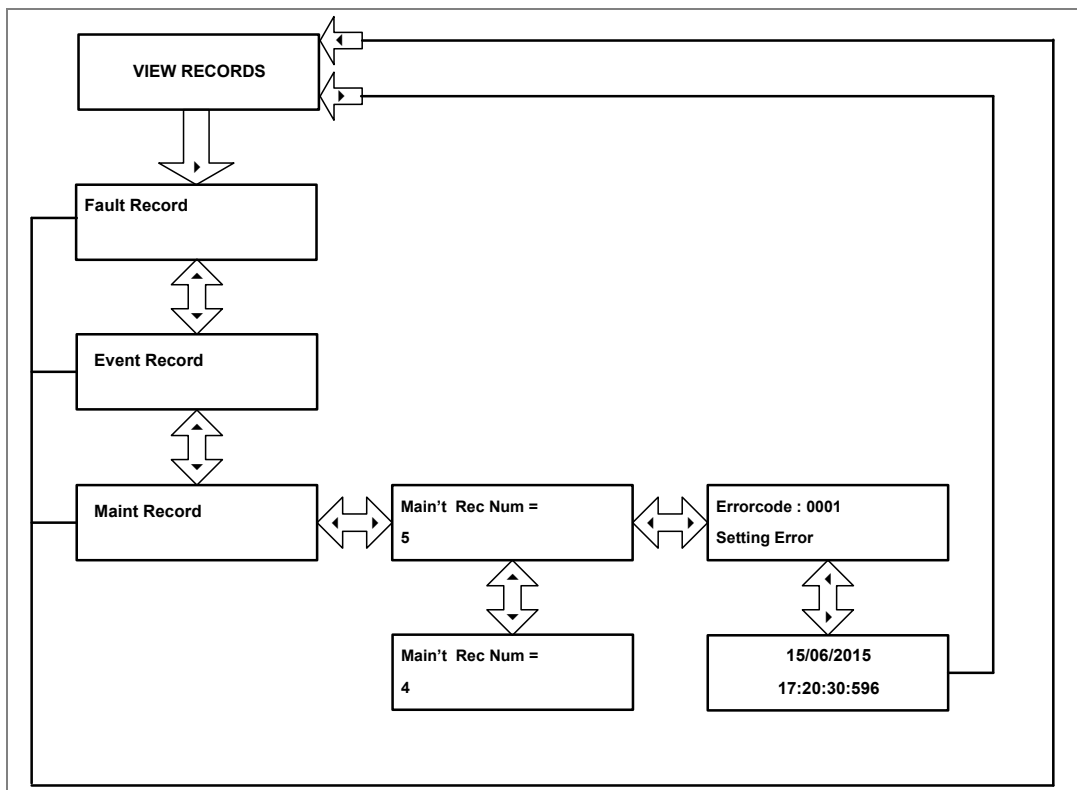

2.4.4.5 View Alarm Records

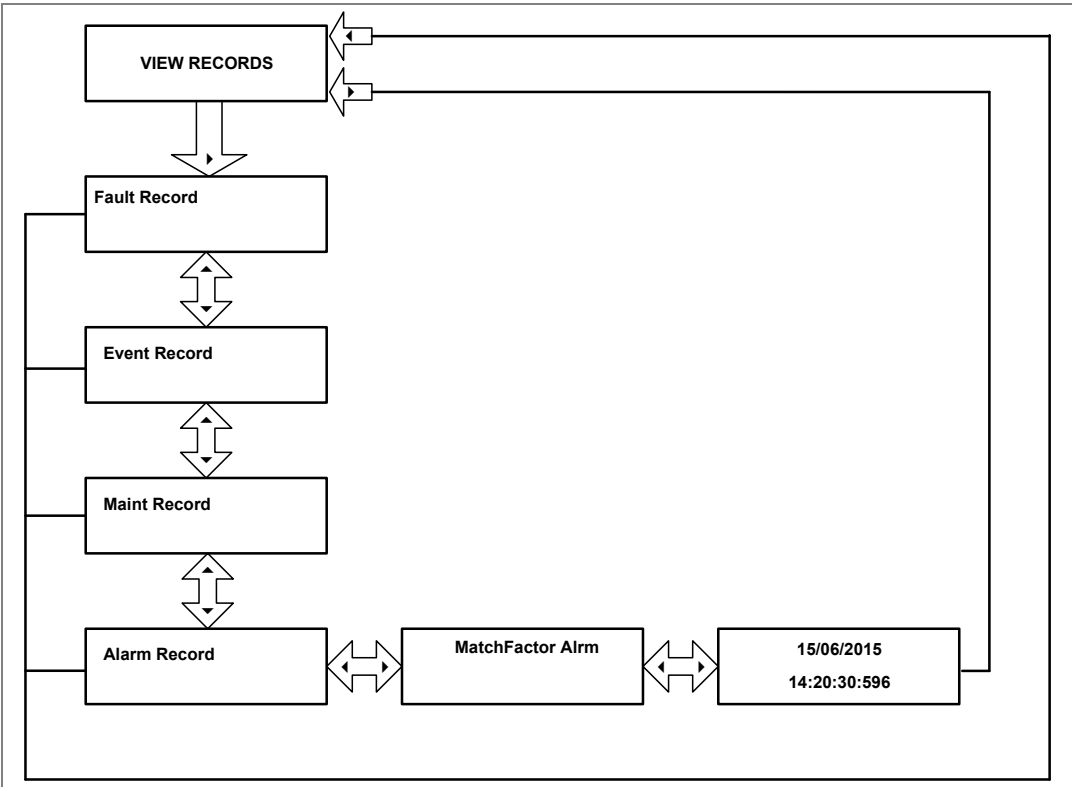

2.4.5 Measurement menu

2.4.5.1 View Measurement 1

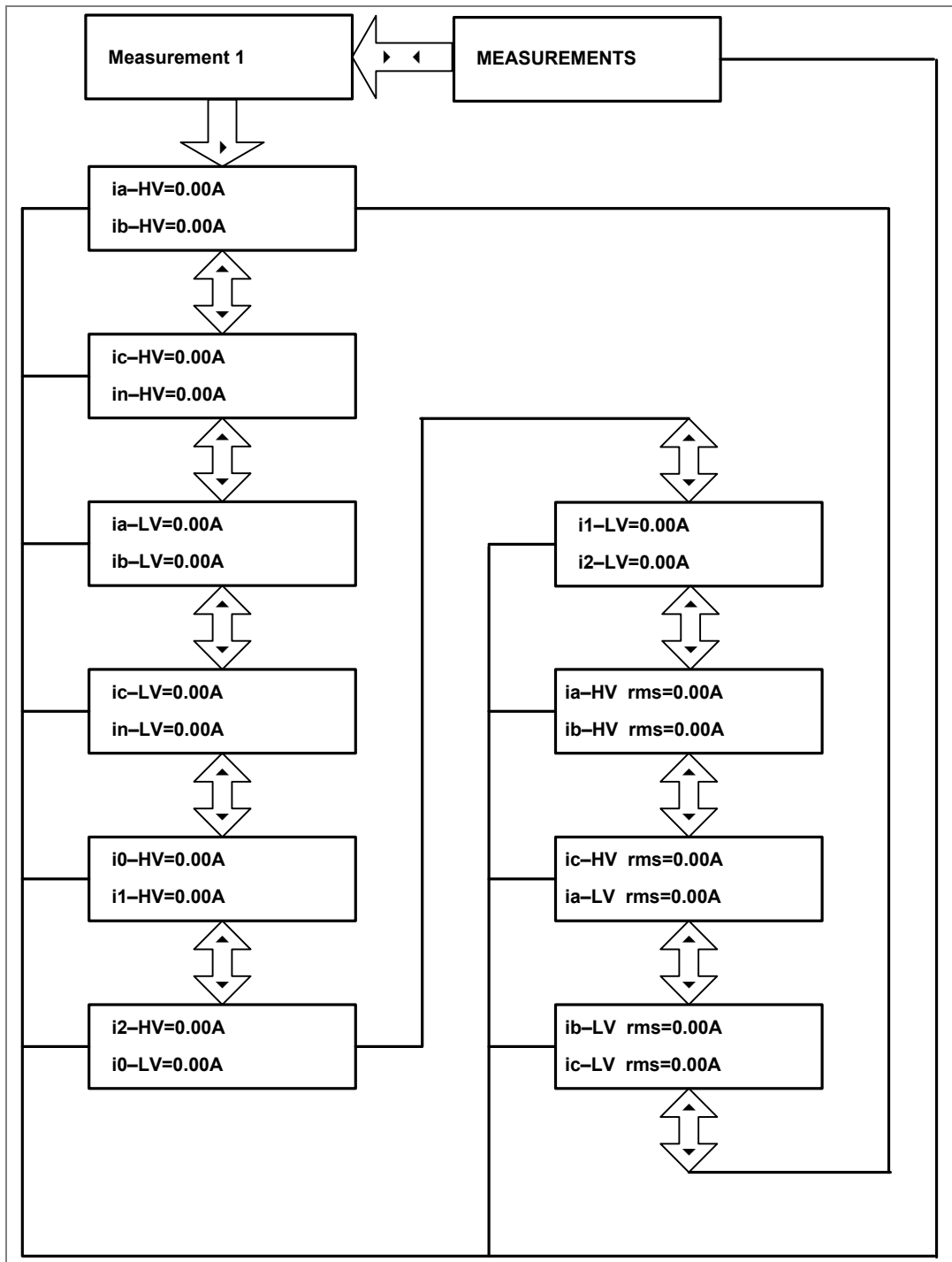

2.4.5.2 View Measurement 2

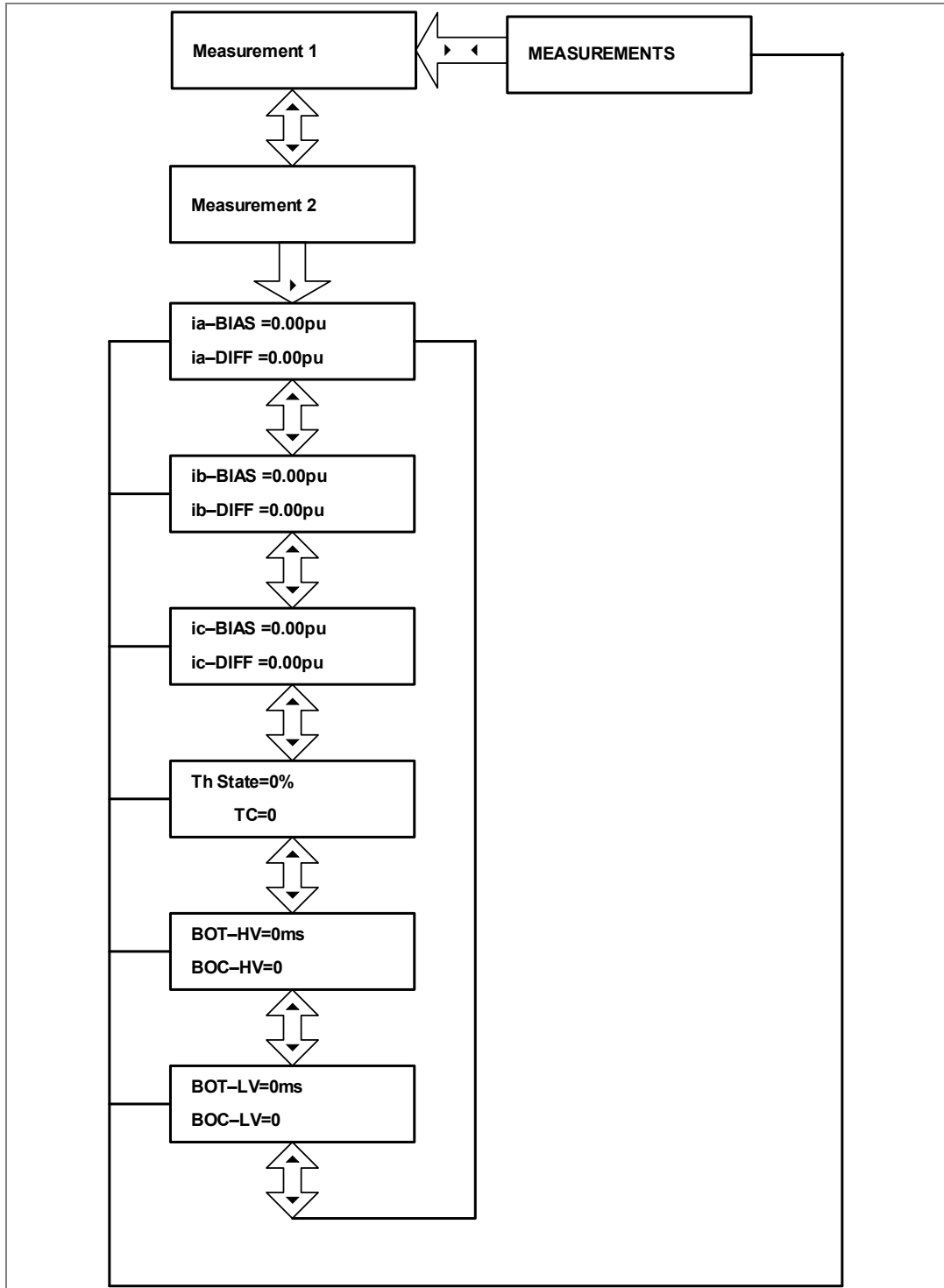

2.4.5.3 View Measurement 3

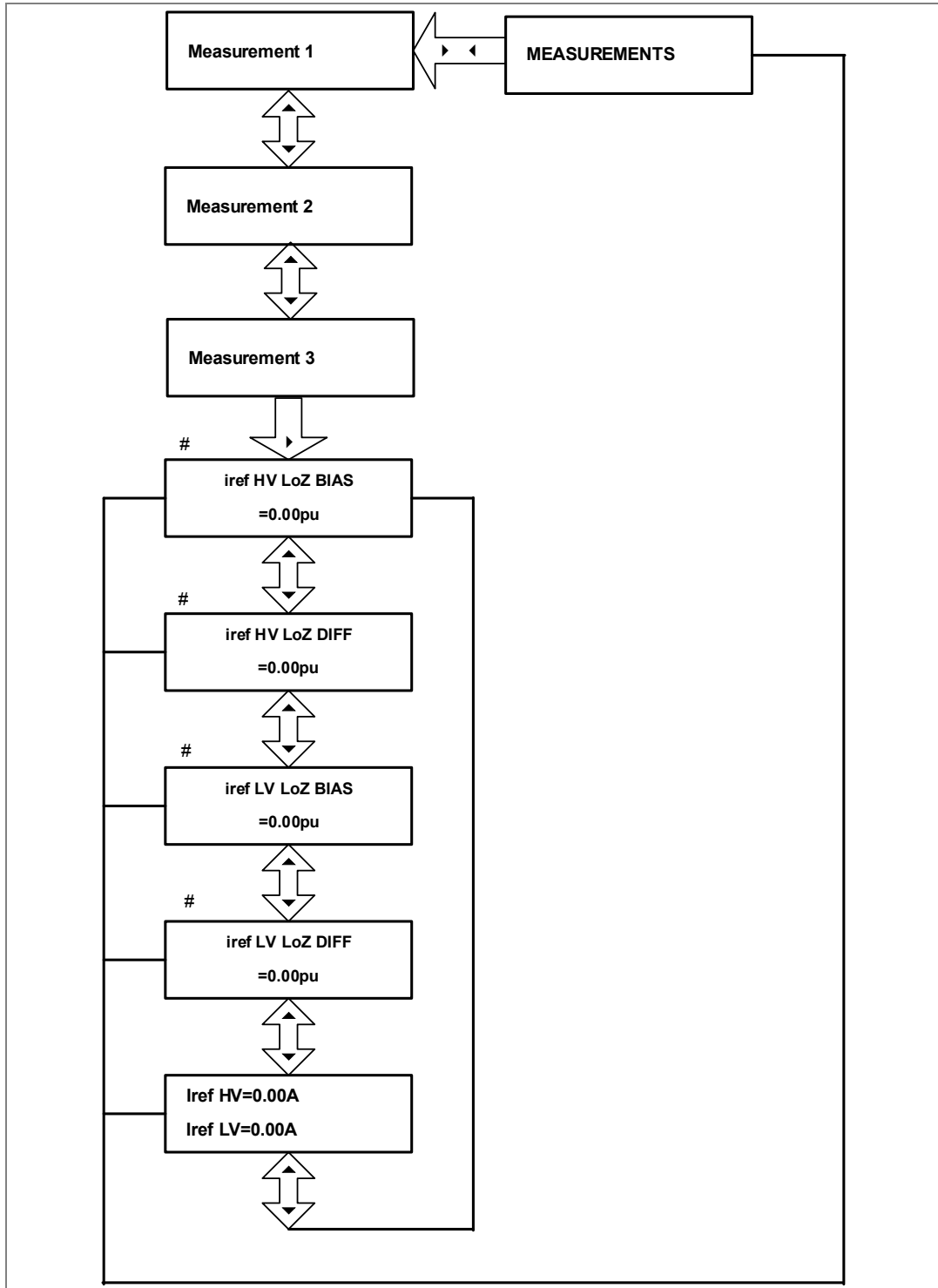

Note: (#) indicates that these measurement are visible only when REF function is select for Low Z operation

2.4.6 CB Control menu

2.4.6.1 View/edit settings (if all settings are disabled)

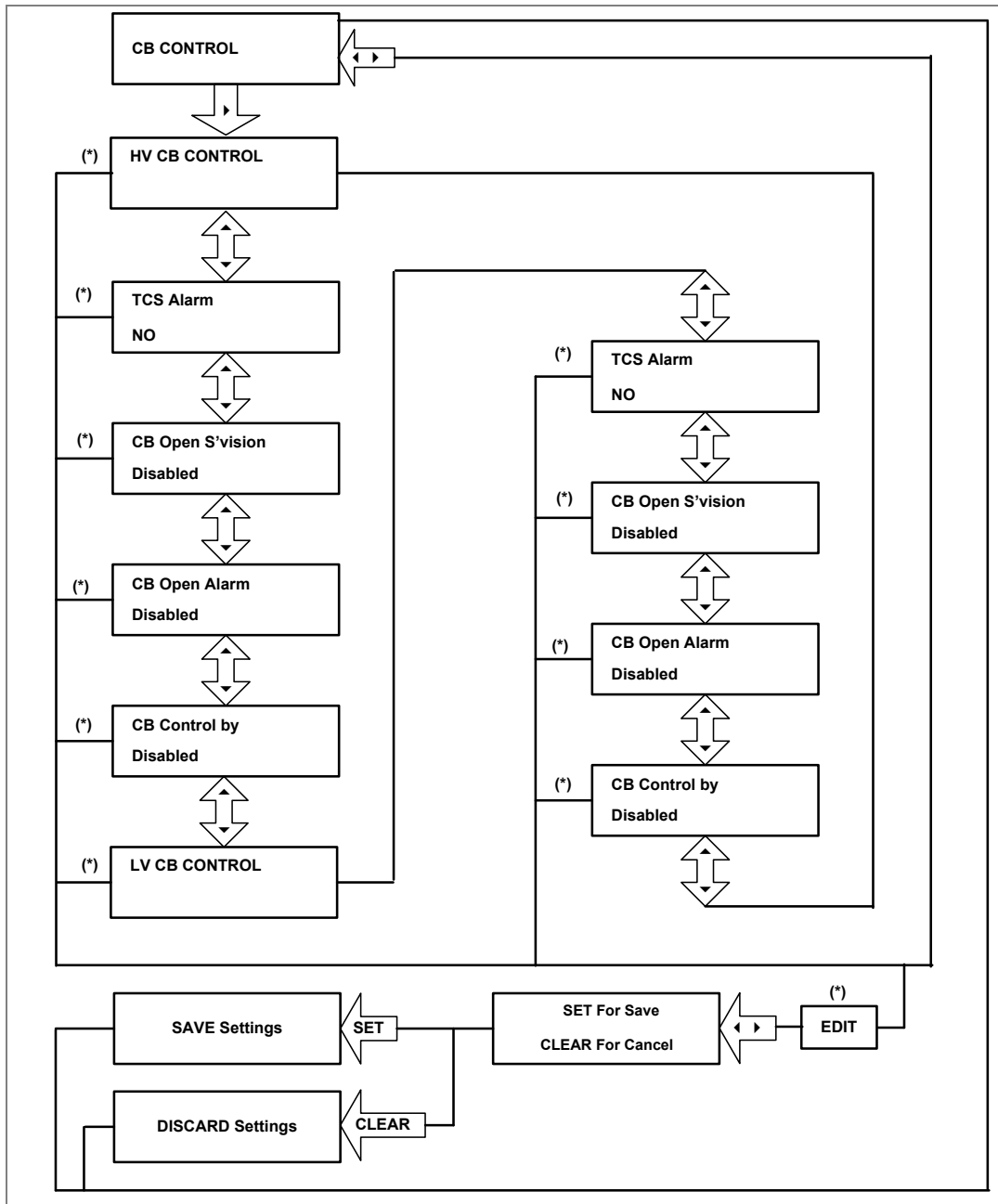

Note: (*) indicates **EDIT** key used to modify settings. Refer to the View and Edit settings section.

2.4.6.2 View/edit settings (if all settings are enabled)

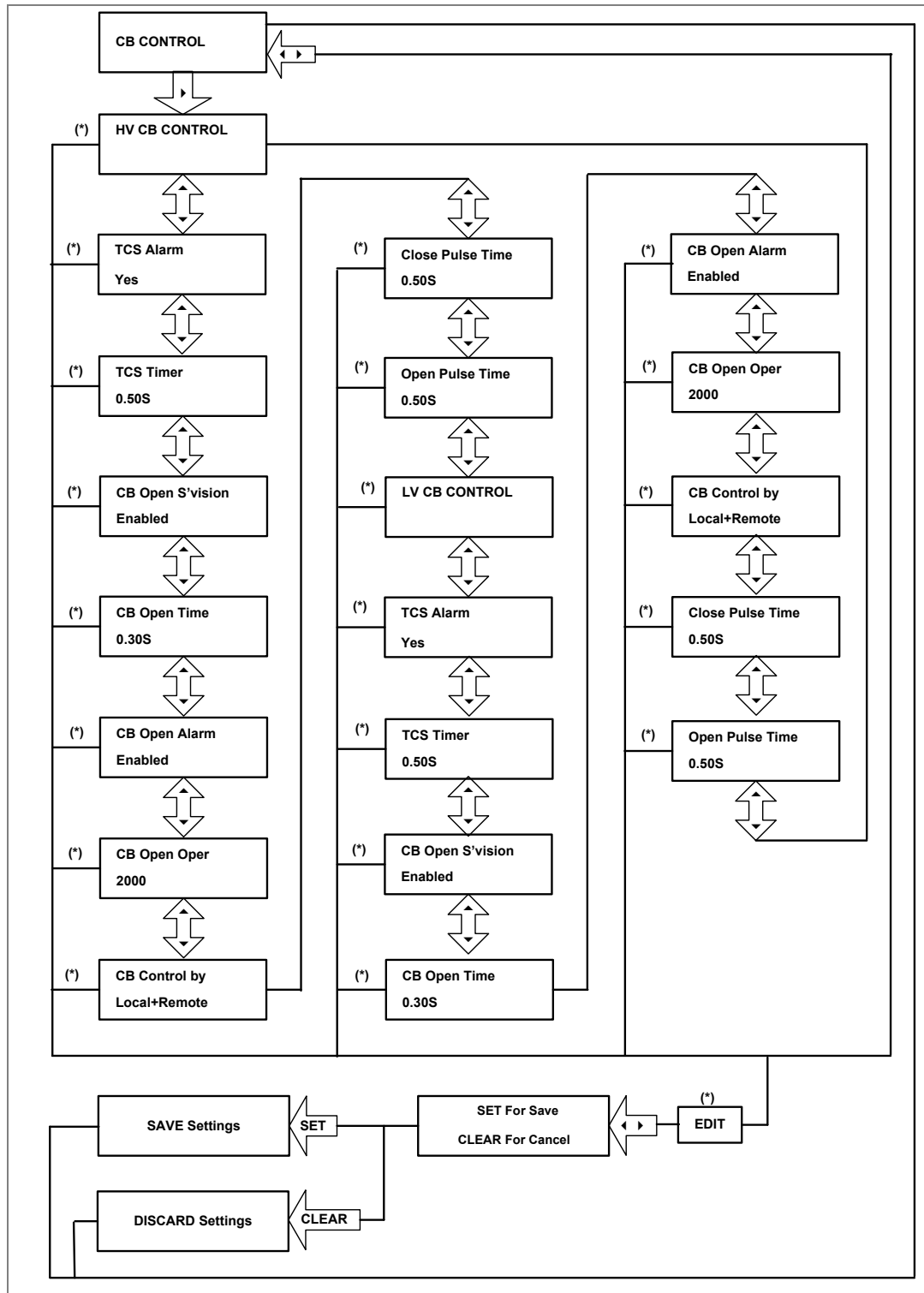

Note: (*) indicates **EDIT** key used to modify settings. Refer to the View and Edit settings section.

2.4.7 Date and Time menu

2.4.7.1 View/edit settings (if all settings are disabled)

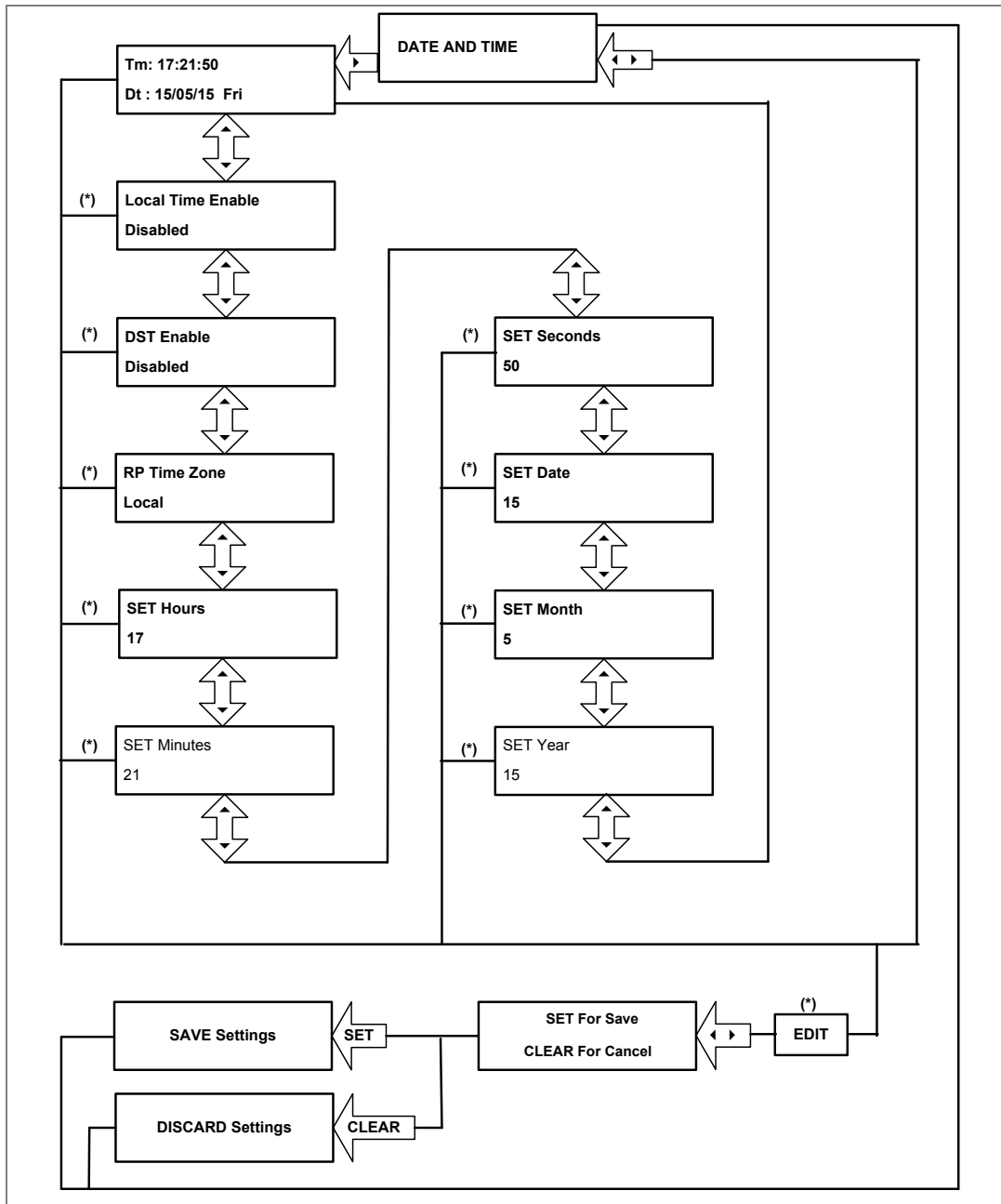

Note: (*) indicates **EDIT** key used to modify settings. Refer to the View and Edit settings section.

2.4.7.2 View/edit settings (if all settings are enabled)

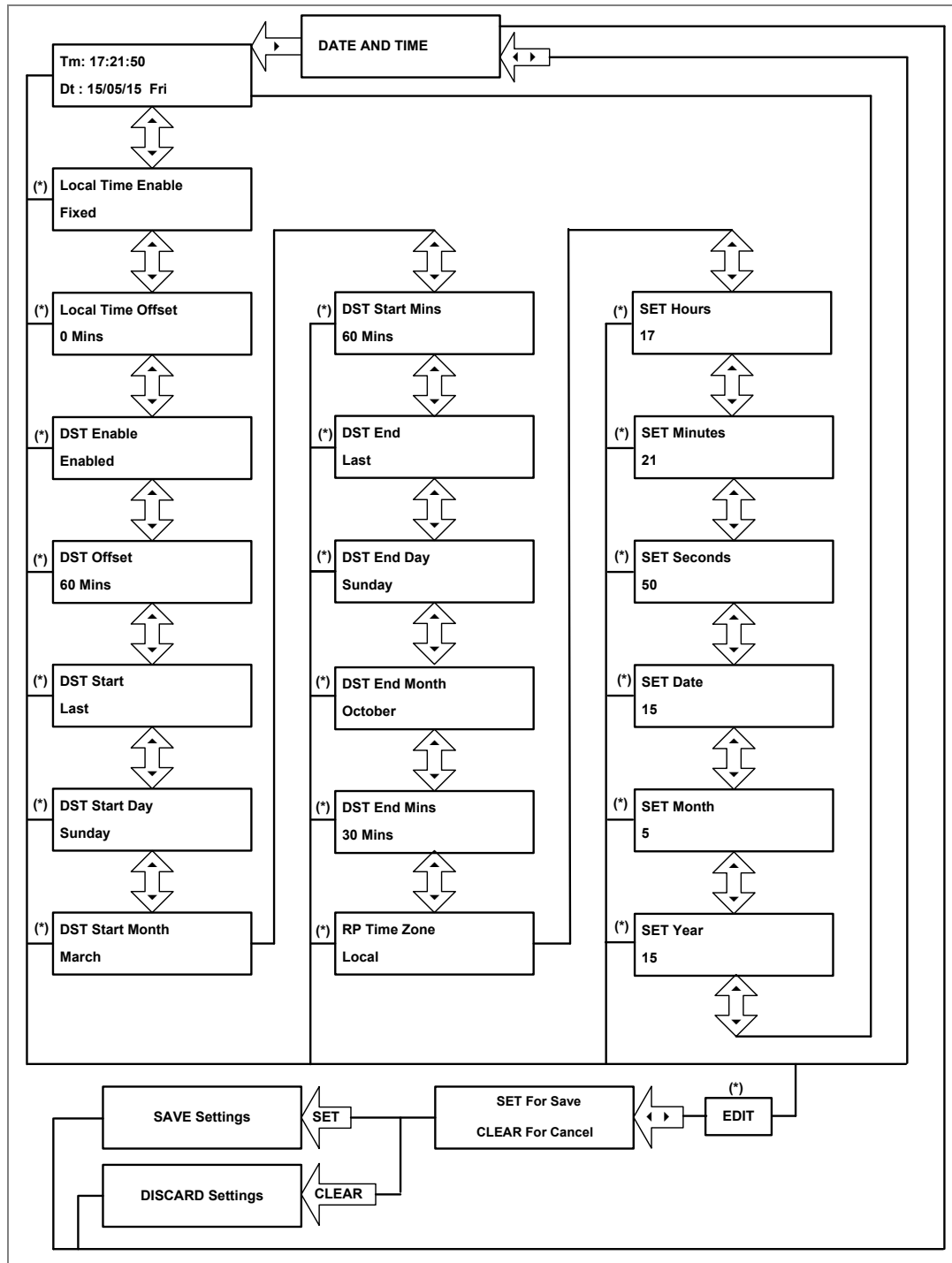

Note: (*) indicates **EDIT** key used to modify settings. Refer to the View and Edit settings section.

2.4.8 Configuration menu

2.4.8.1 View/edit settings

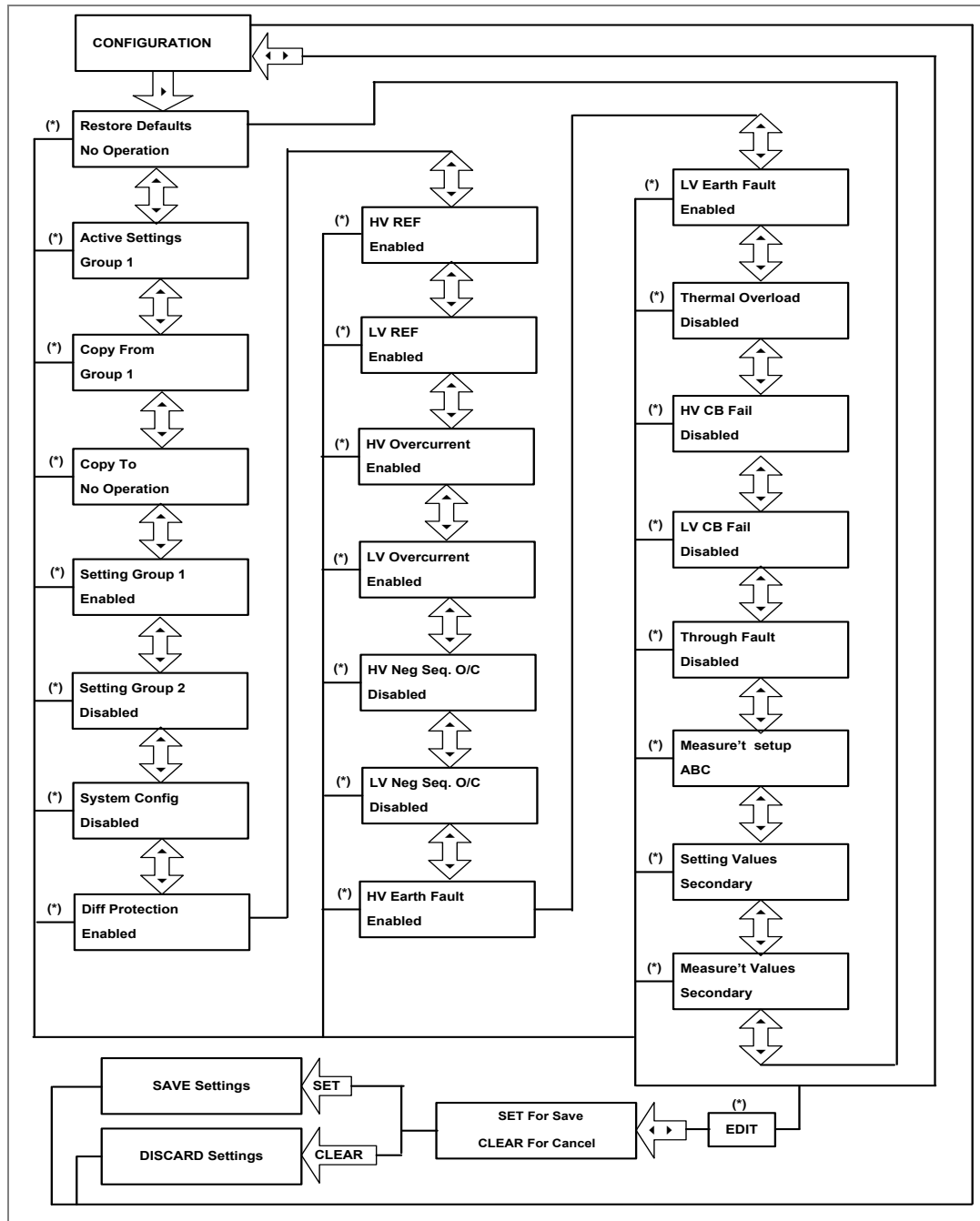

Note: (*) indicates **EDIT** key used to modify settings. Refer to the View and Edit settings section.

2.4.9 Transformer Ratios menu

2.4.9.1 View/edit settings

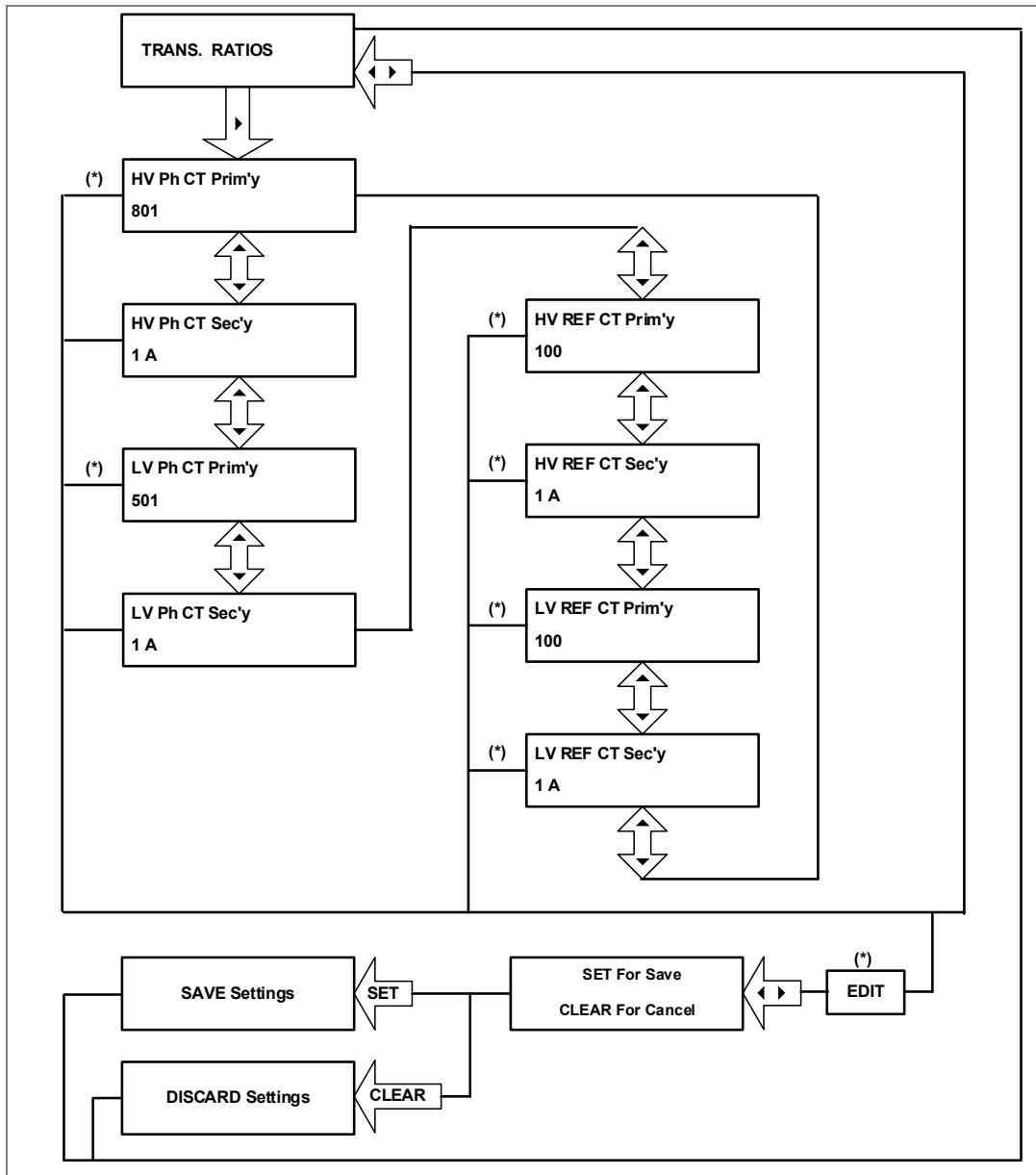

Note: (*) indicates **EDIT** key used to modify settings. Refer to the View and Edit settings section.

2.4.10 Record Control menu

2.4.10.1 View/edit settings

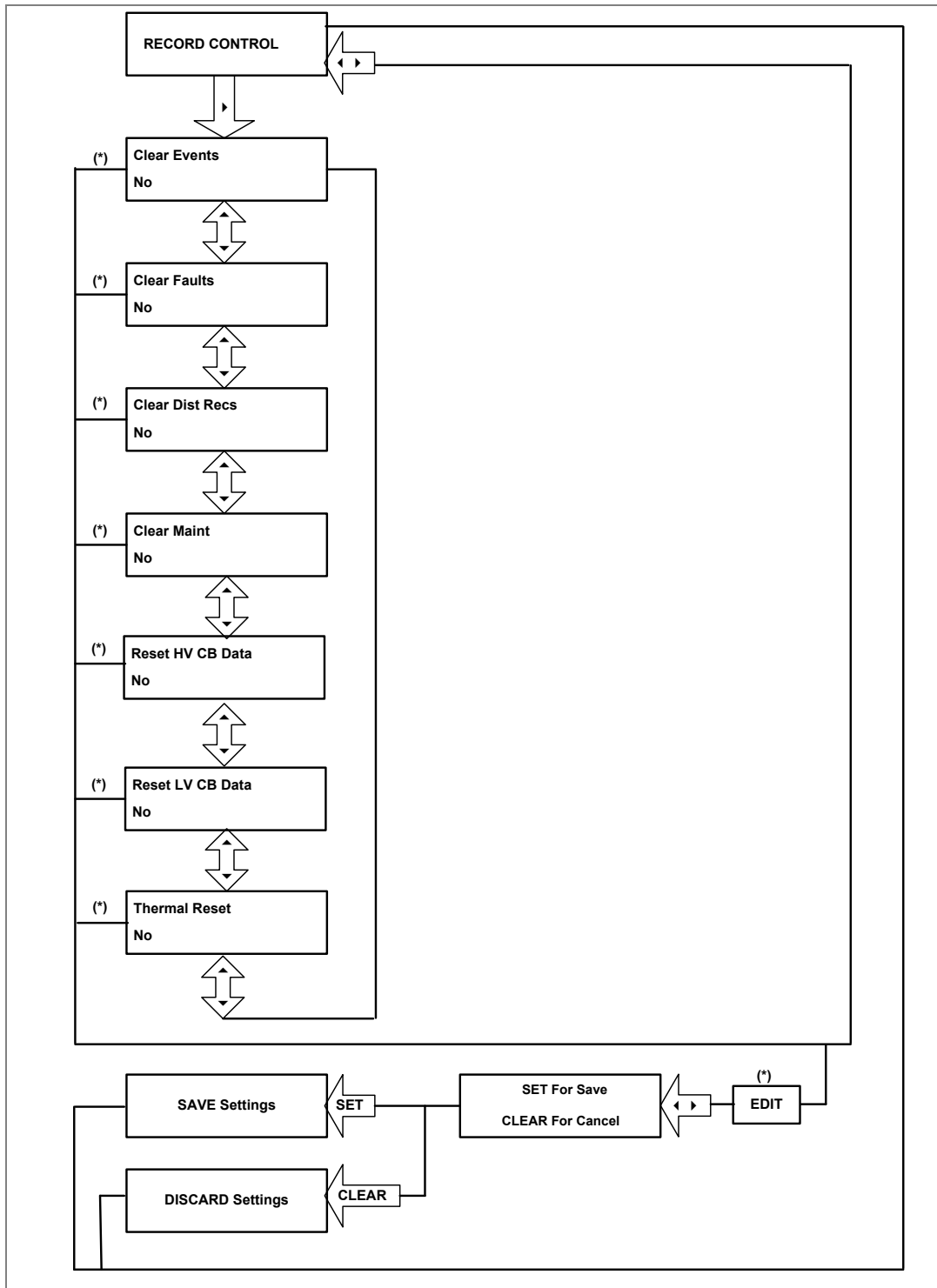

Note: (*) indicates **EDIT** key used to modify settings. Refer to the View and Edit settings section.

2.4.11 Communication menu

2.4.12 View/edit settings

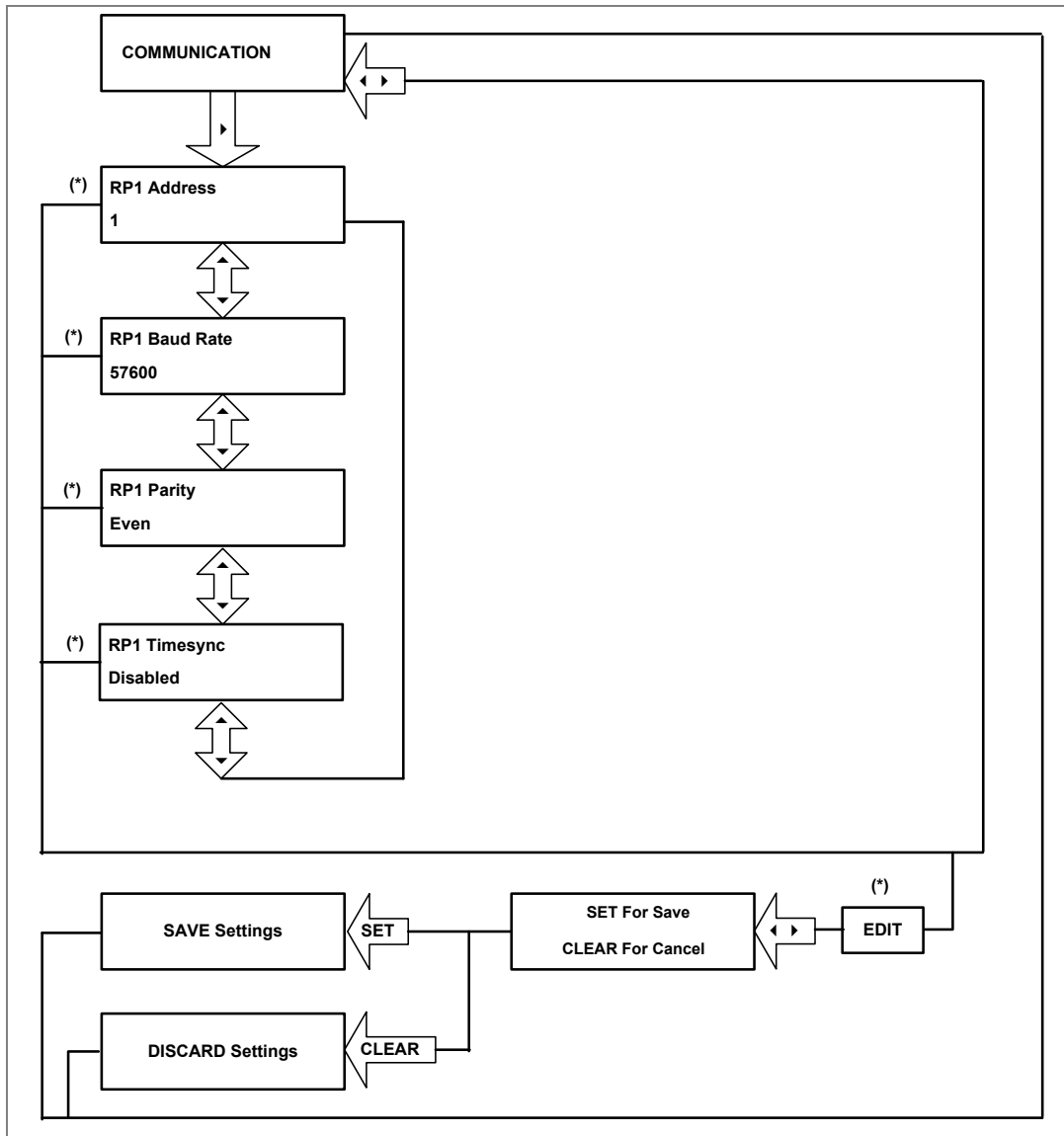

Note: (*) indicates **EDIT** key used to modify settings. Refer to the View and Edit settings section.

2.4.13 I/O Configuration menu

2.4.14 View/edit settings

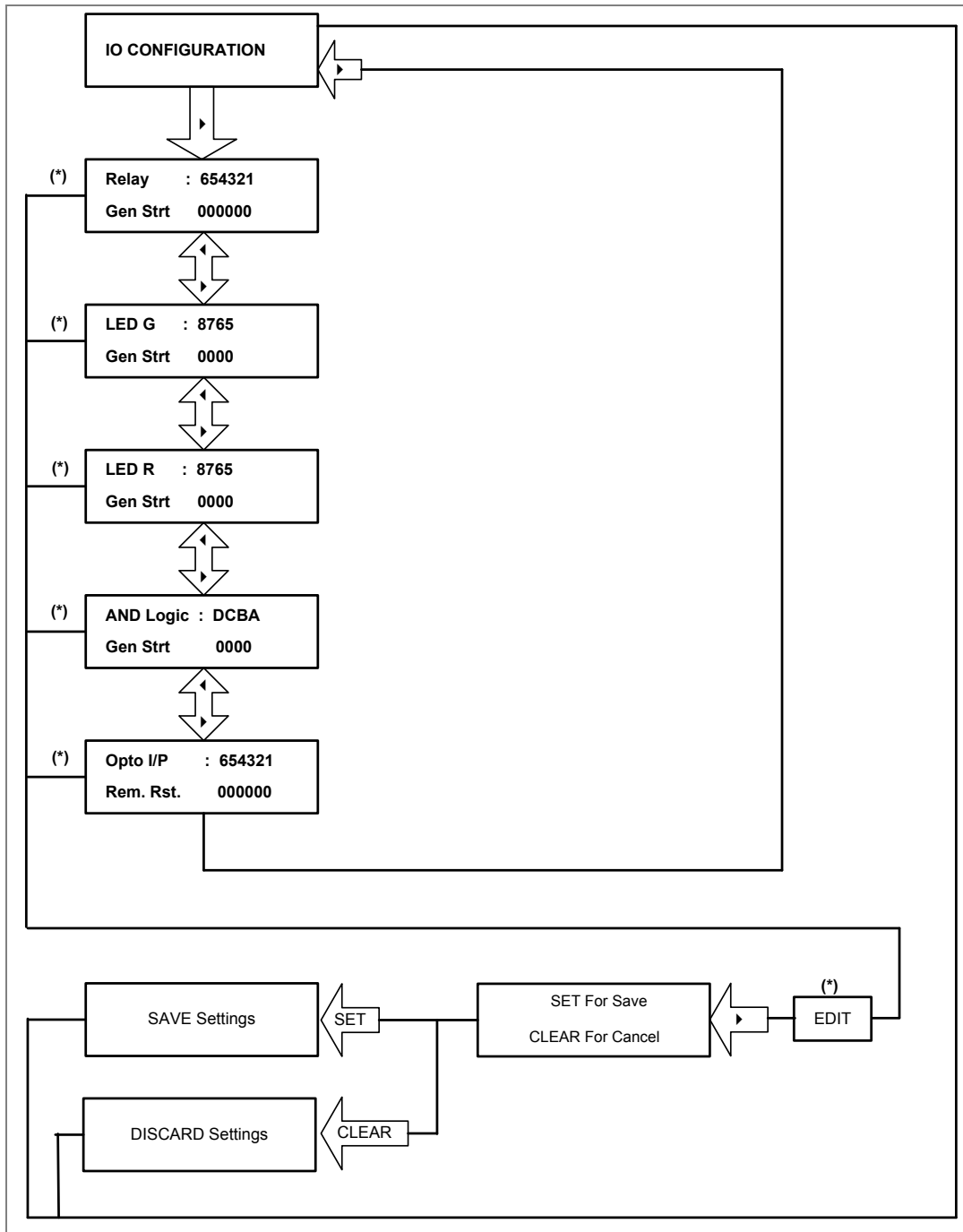

Note: (*) indicates **EDIT** key used to modify settings. Refer to the View and Edit settings section.

2.4.14.1.1 I/O Configuration submenu setting

(Output relays, LEDs and AND logic settings)

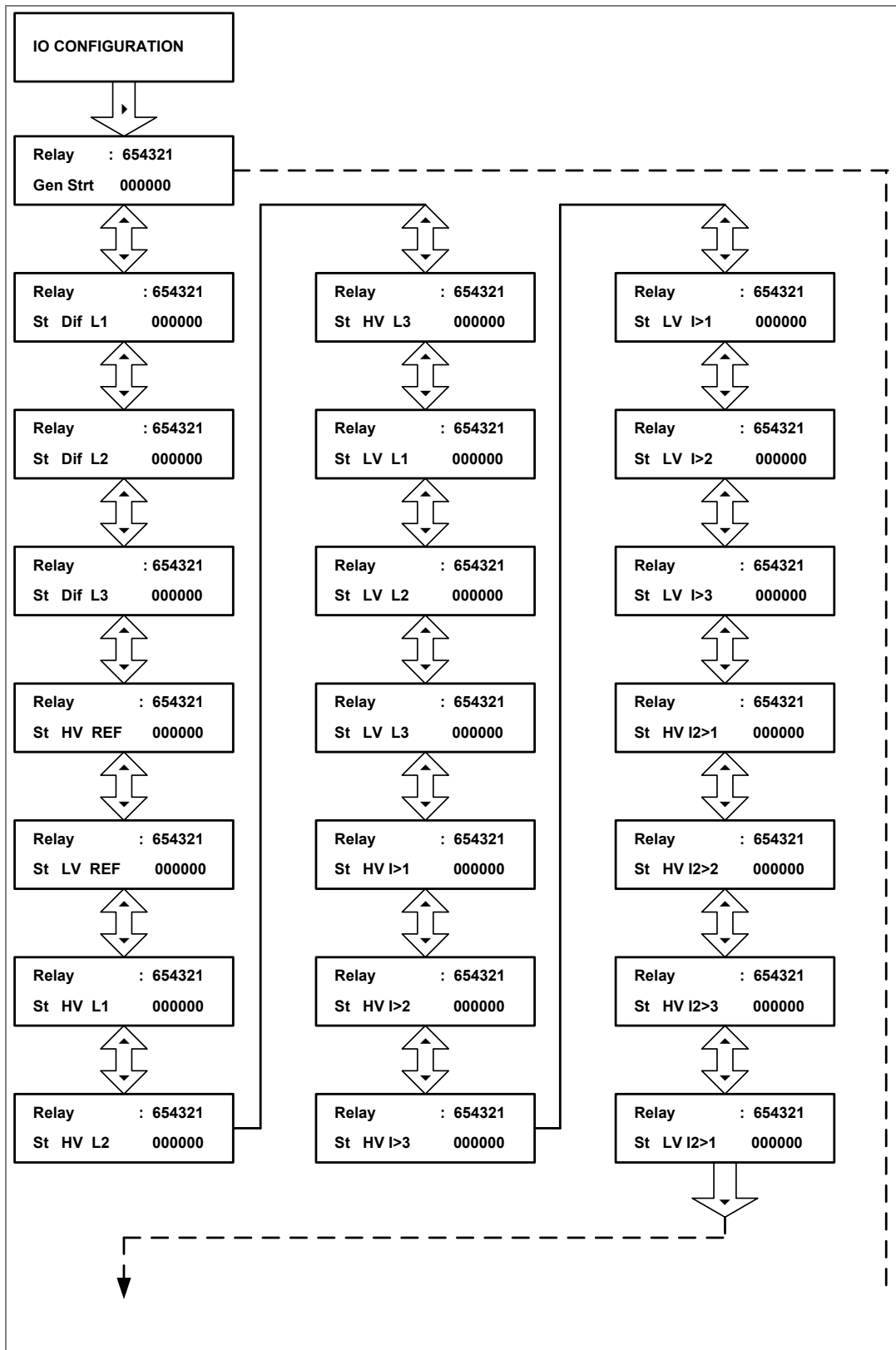

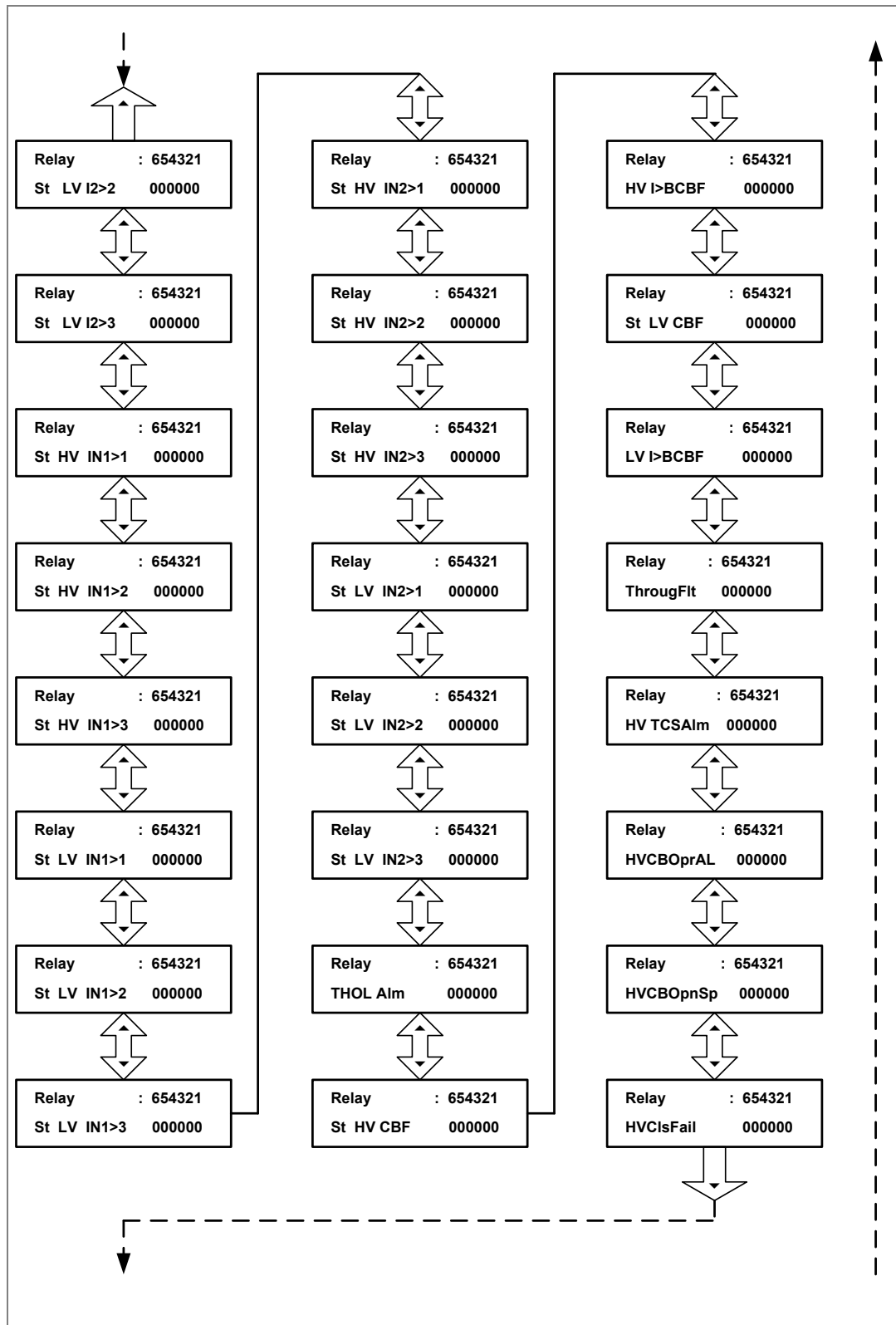

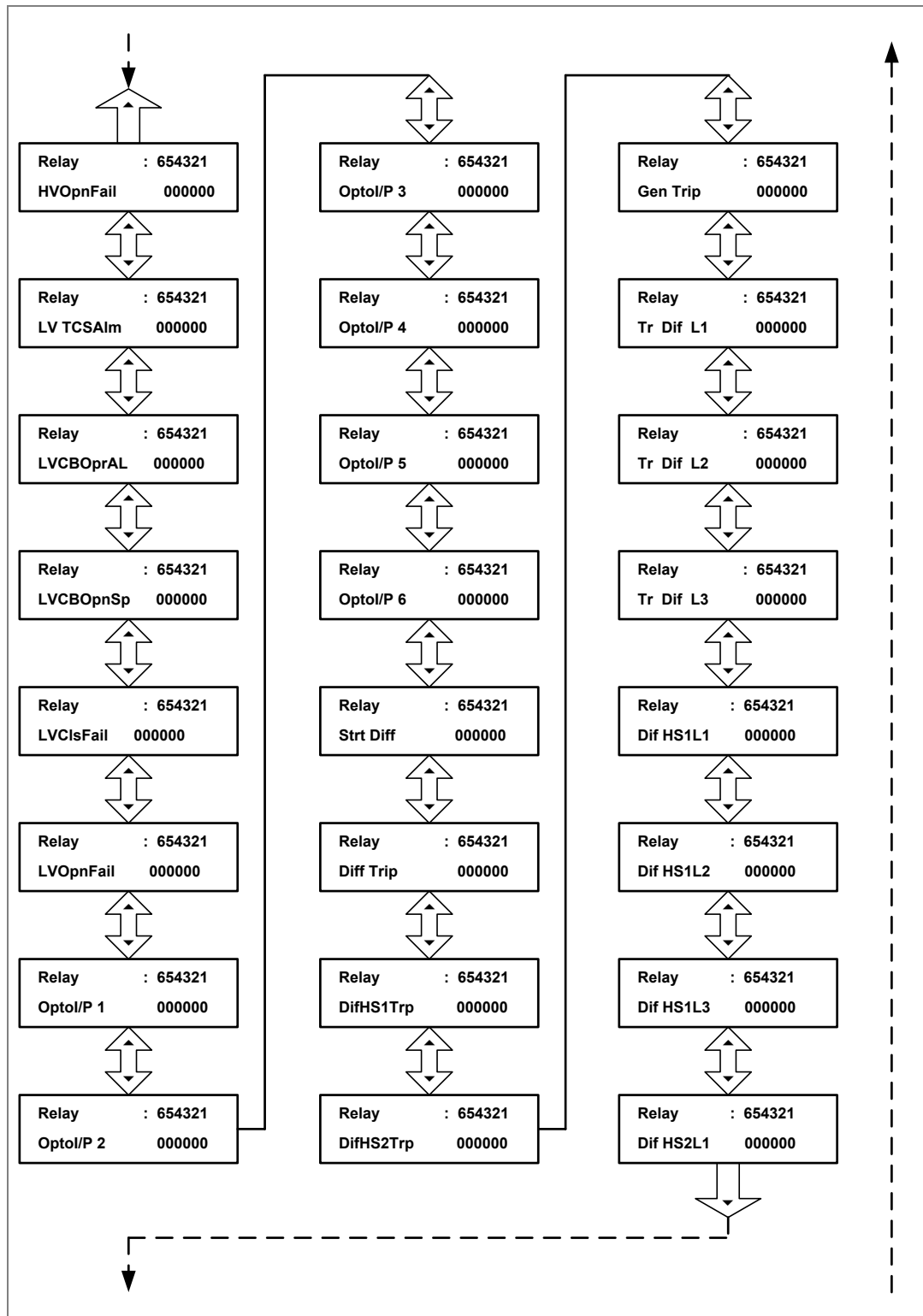

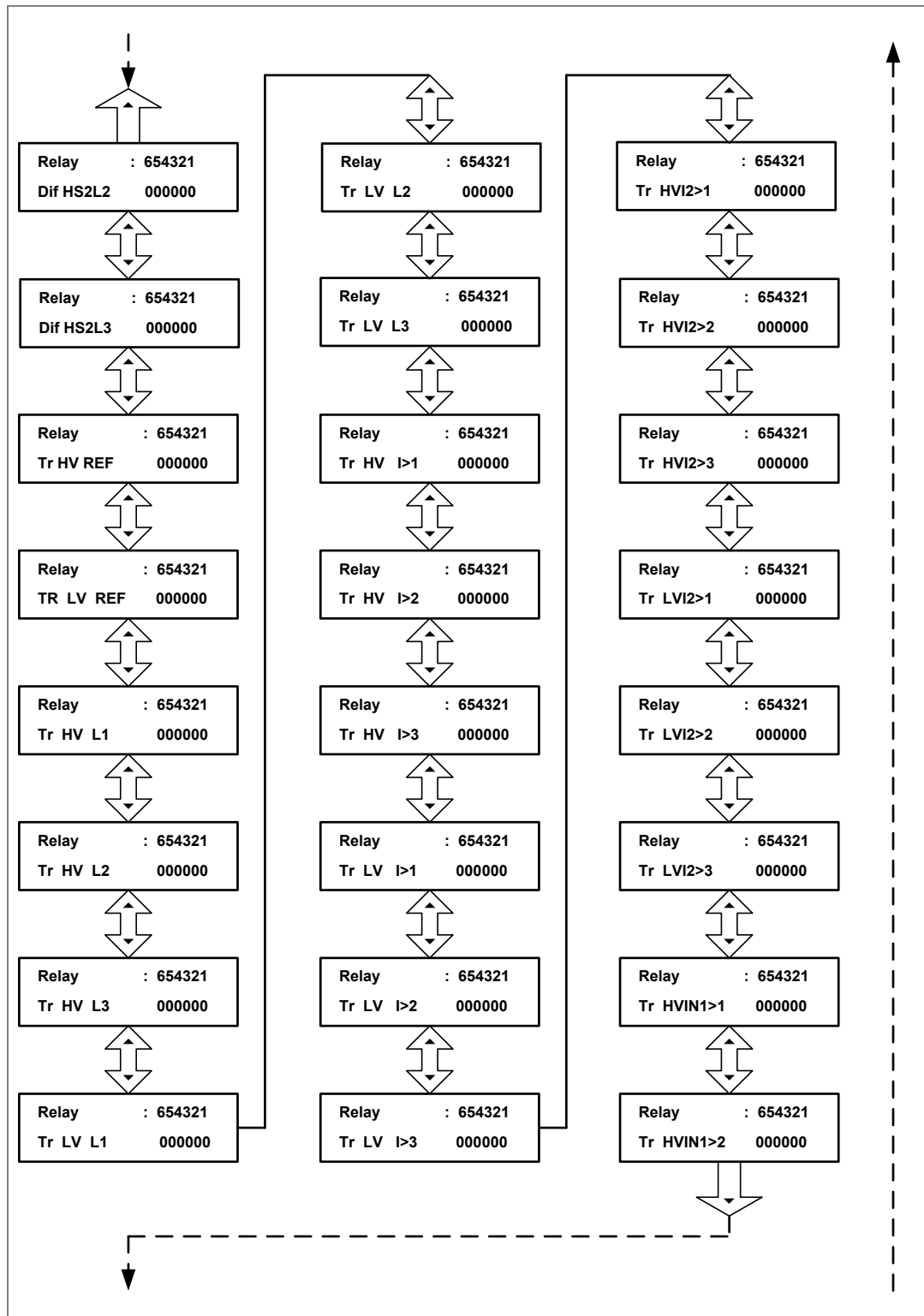

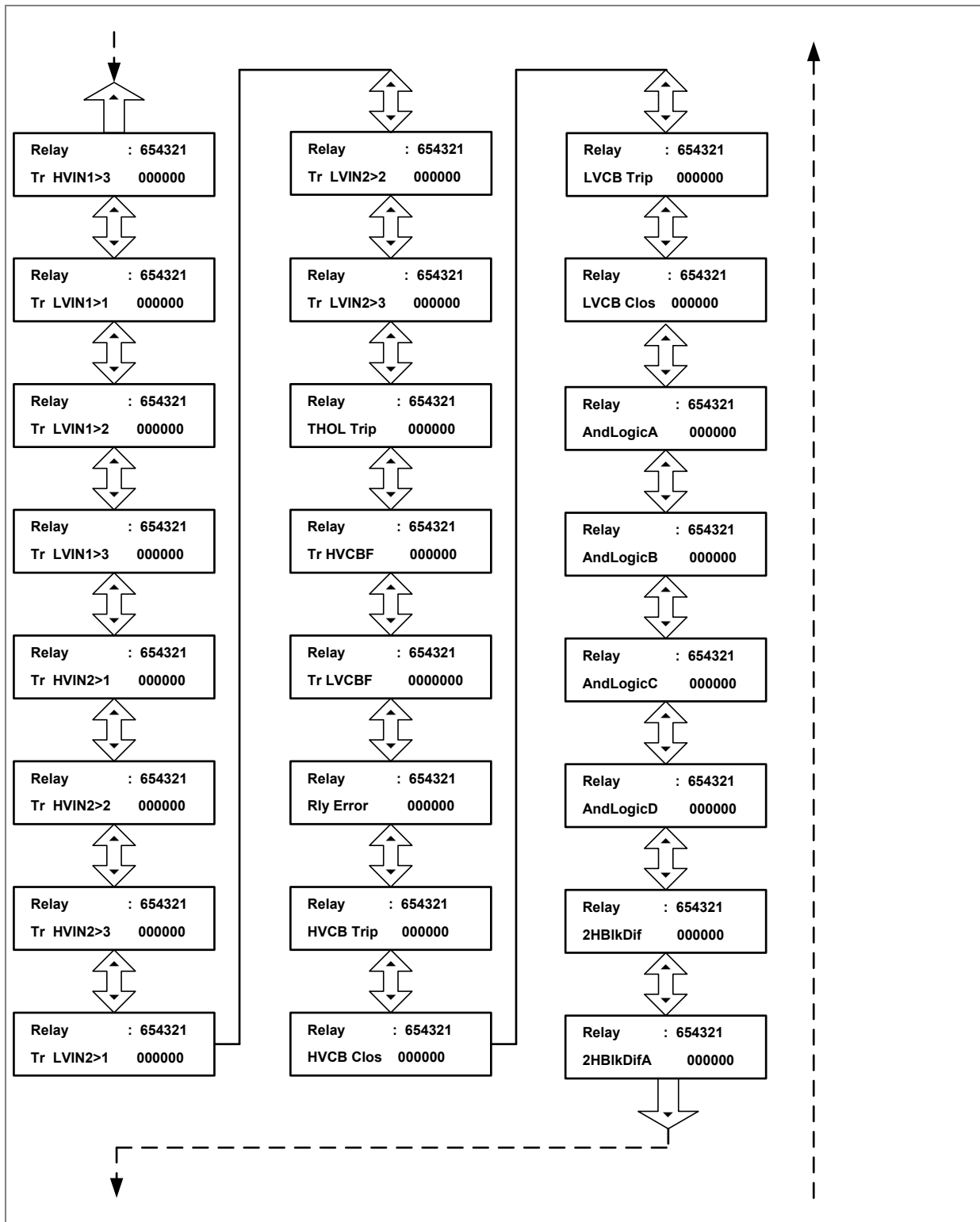

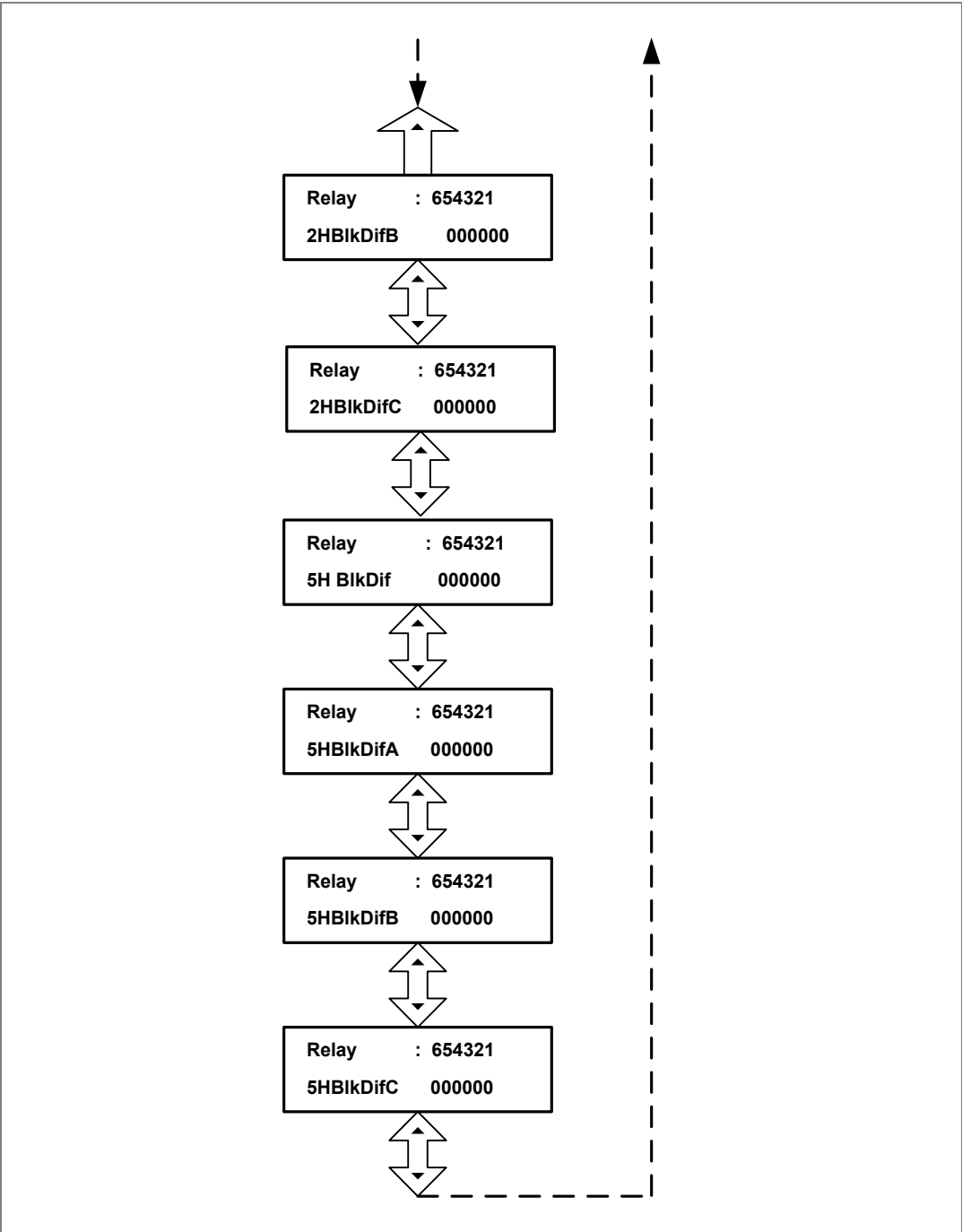

2.4.14.1.2 I/O Configuration submenu setting (Opto I/ps)

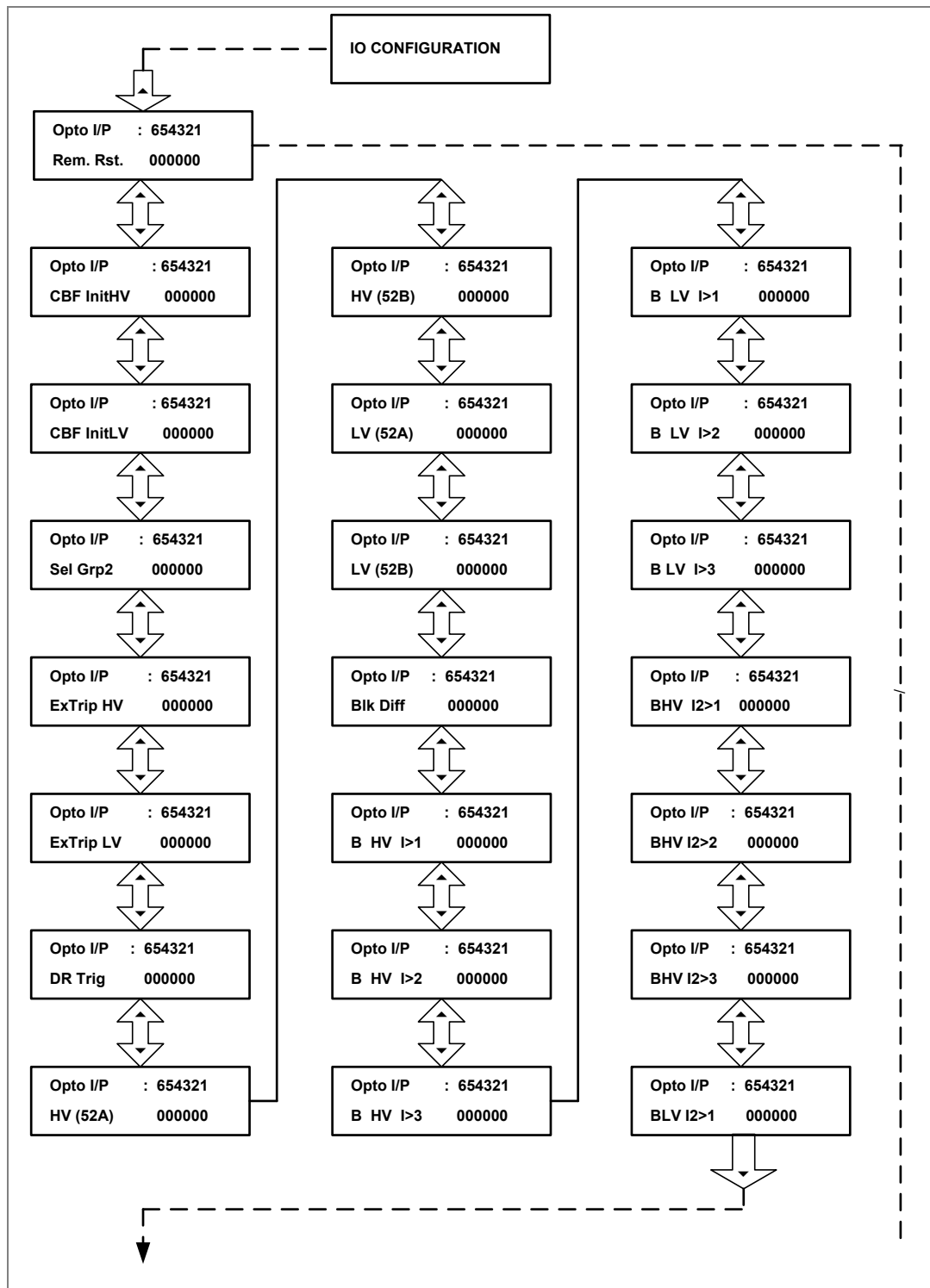

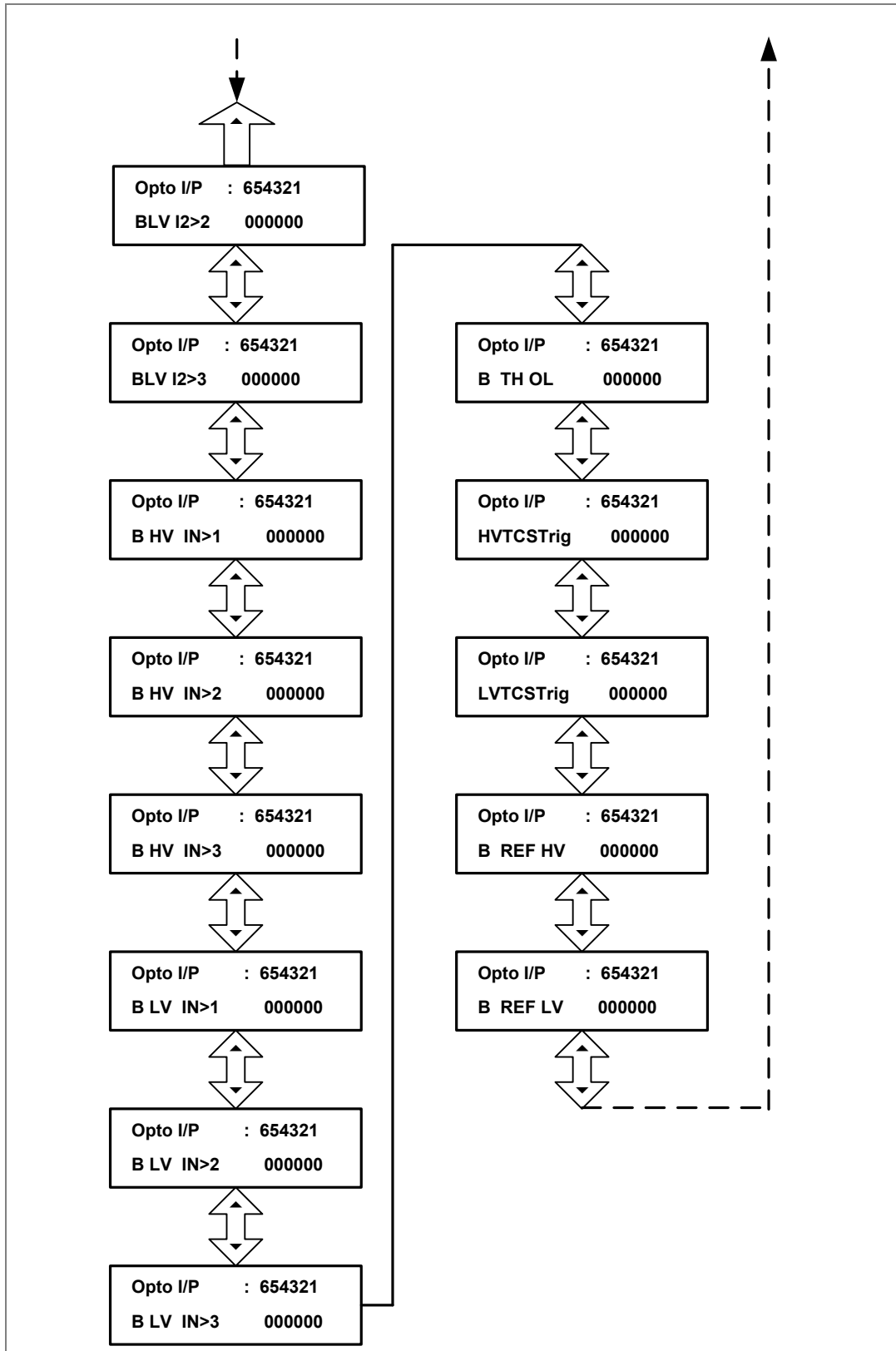

2.4.15 O/P Relay Configuration menu

2.4.15.1 View/edit settings

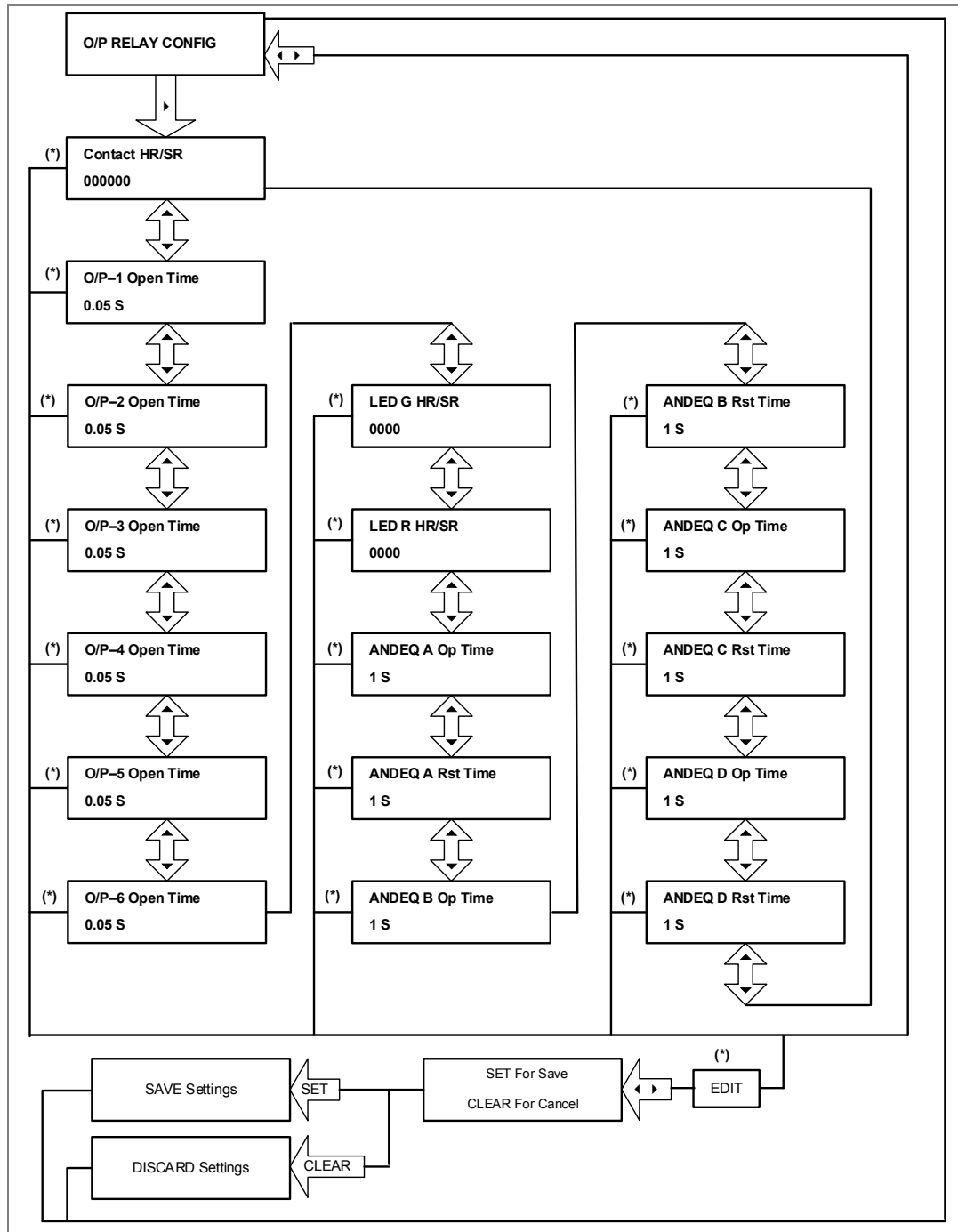

Note: (*) indicates **EDIT** key used to modify settings. Refer to the View and Edit settings section.

2.4.16 Disturbance Record menu

2.4.16.1 View/edit settings

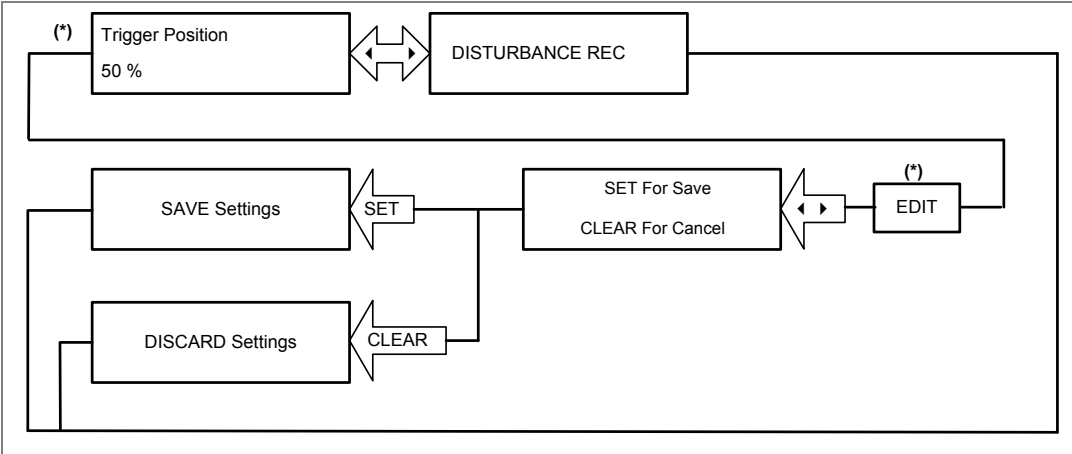

Note: (*) indicates **EDIT** key used to modify settings. Refer to the View and Edit settings section.

2.4.17 Commissioning Test menu

2.4.17.1 View/edit settings

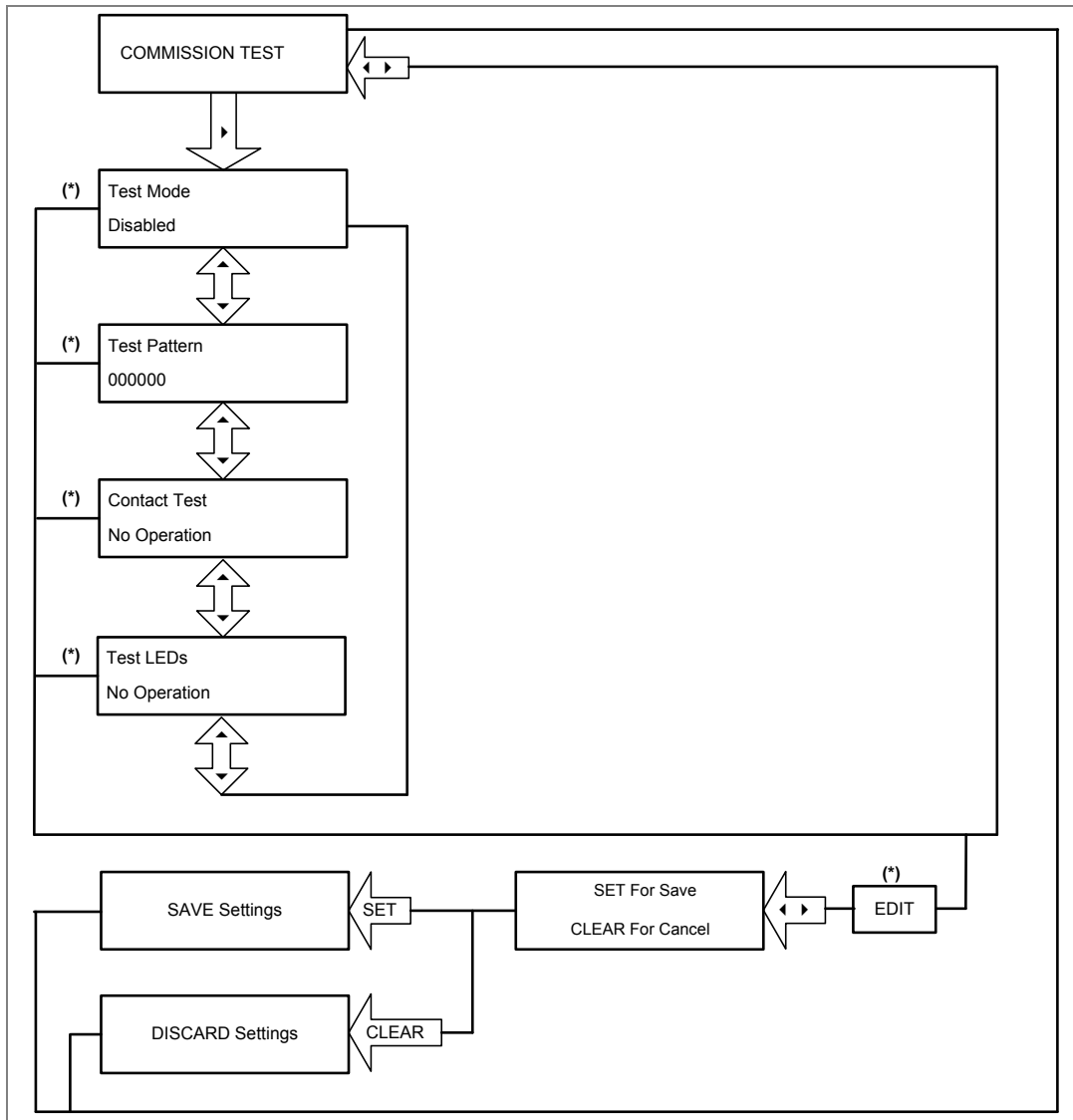

Note: (*) indicates **EDIT** key used to modify settings. Refer to the View and Edit settings section.

2.4.18 Group1 menu

2.4.18.1 View/edit settings

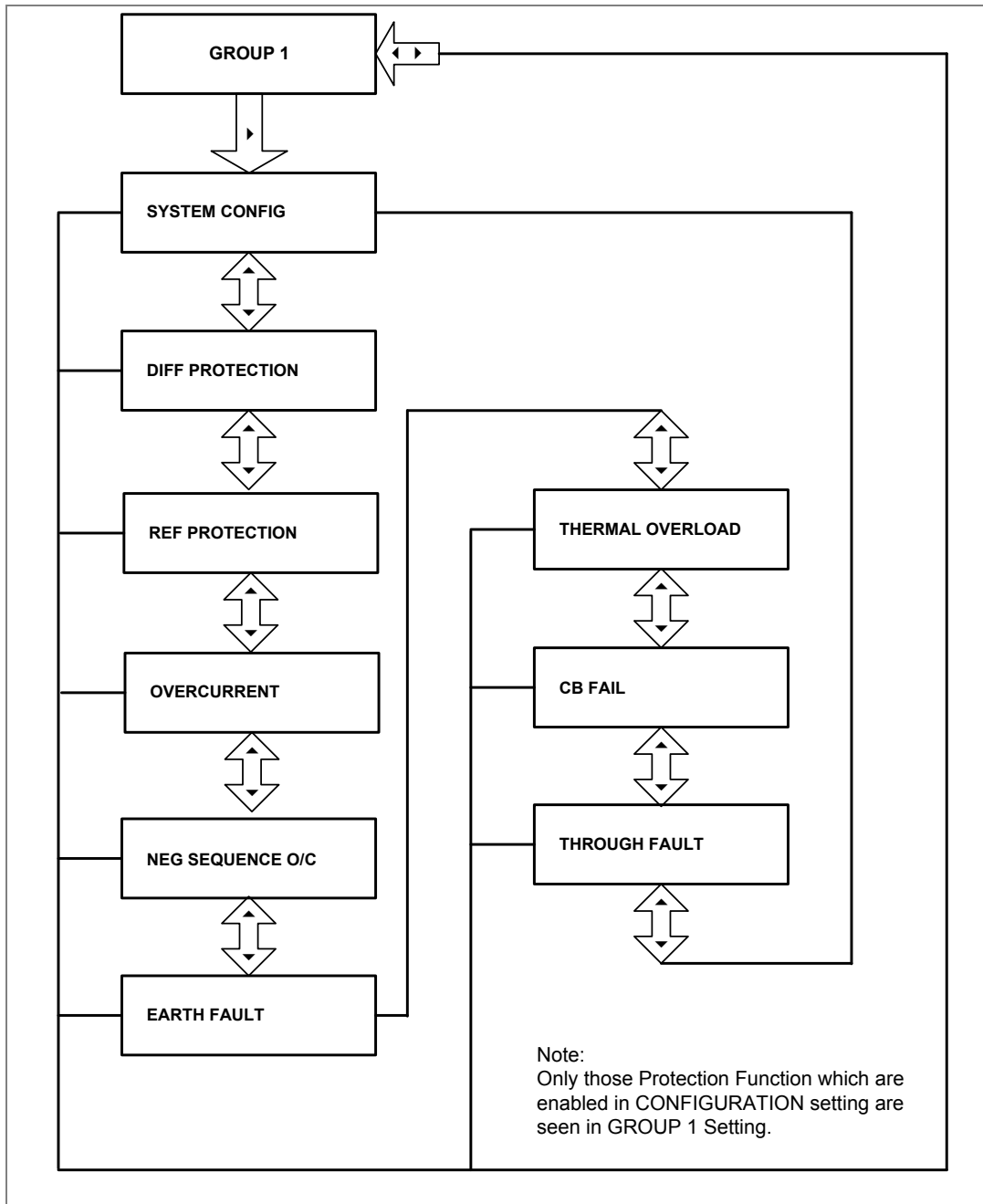

2.4.18.2 Group1 System Configuration submenu

2.4.18.2.1 View/edit settings (If the setting is enabled)

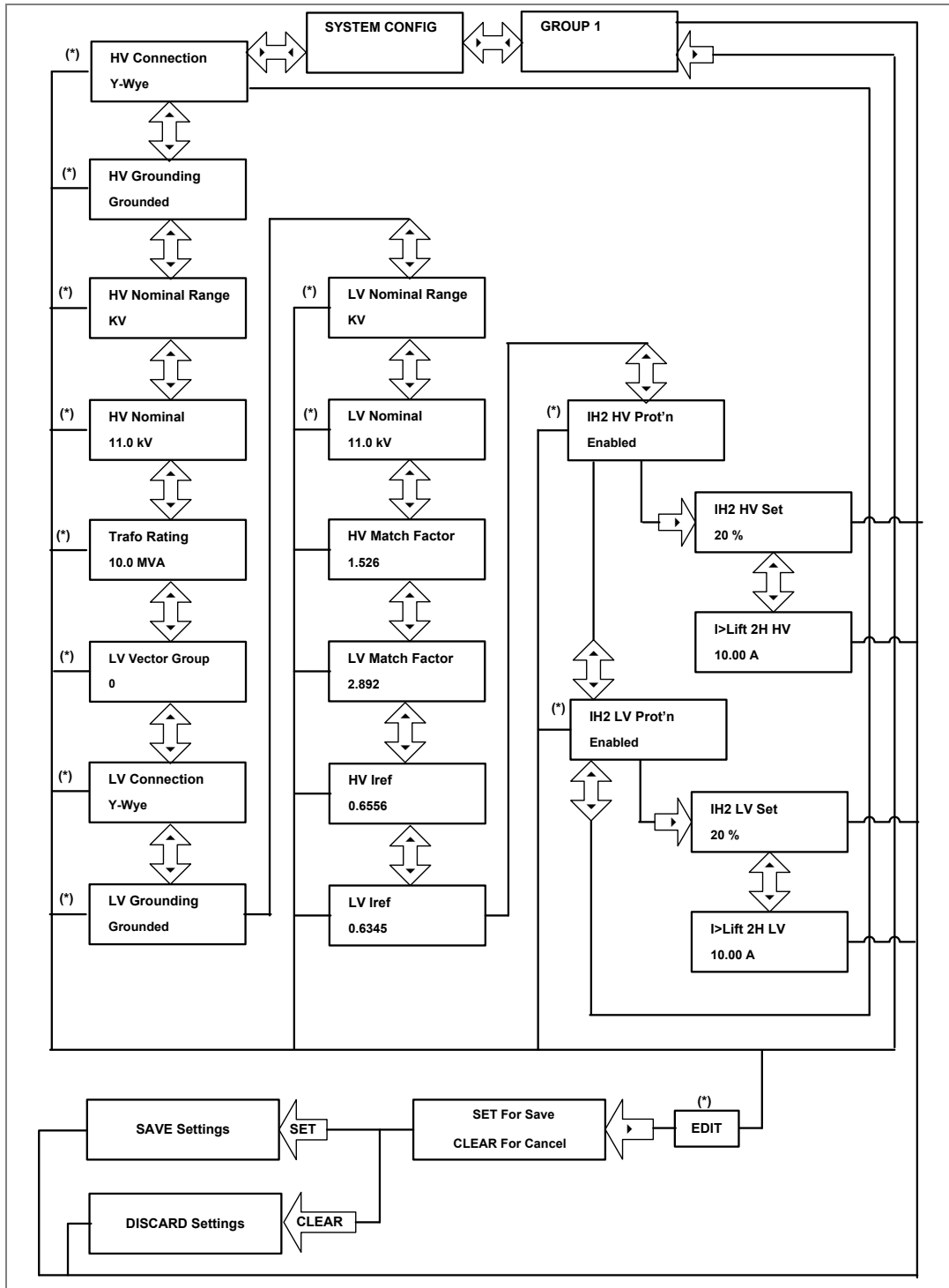

Note: (*) indicates **EDIT** key used to modify settings. Refer to the View and Edit settings section.

2.4.18.3 Group1 DIFF PROTECTION submenu

2.4.18.3.1 View/edit settings (If the setting is disabled)

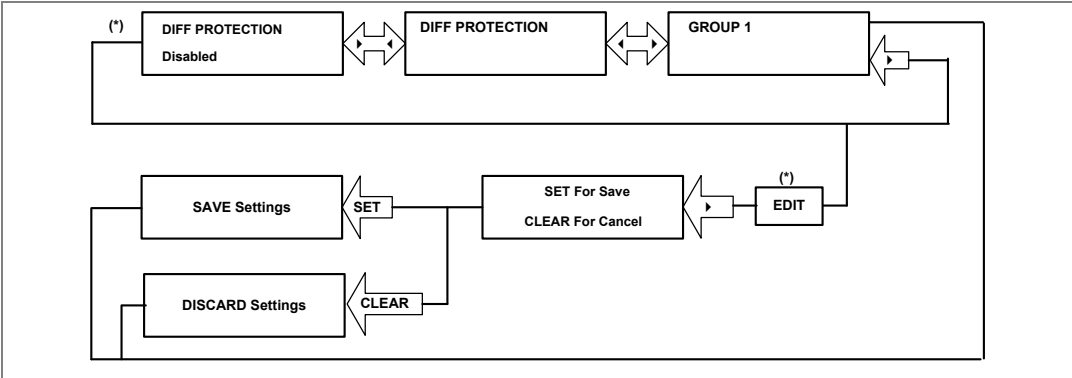

Note: (*) indicates **EDIT** key used to modify settings. Refer to the View and Edit settings section.

2.4.18.3.2 View/edit settings (If Diff Protection, IH2 & IH5 Diff Block setting is enabled)

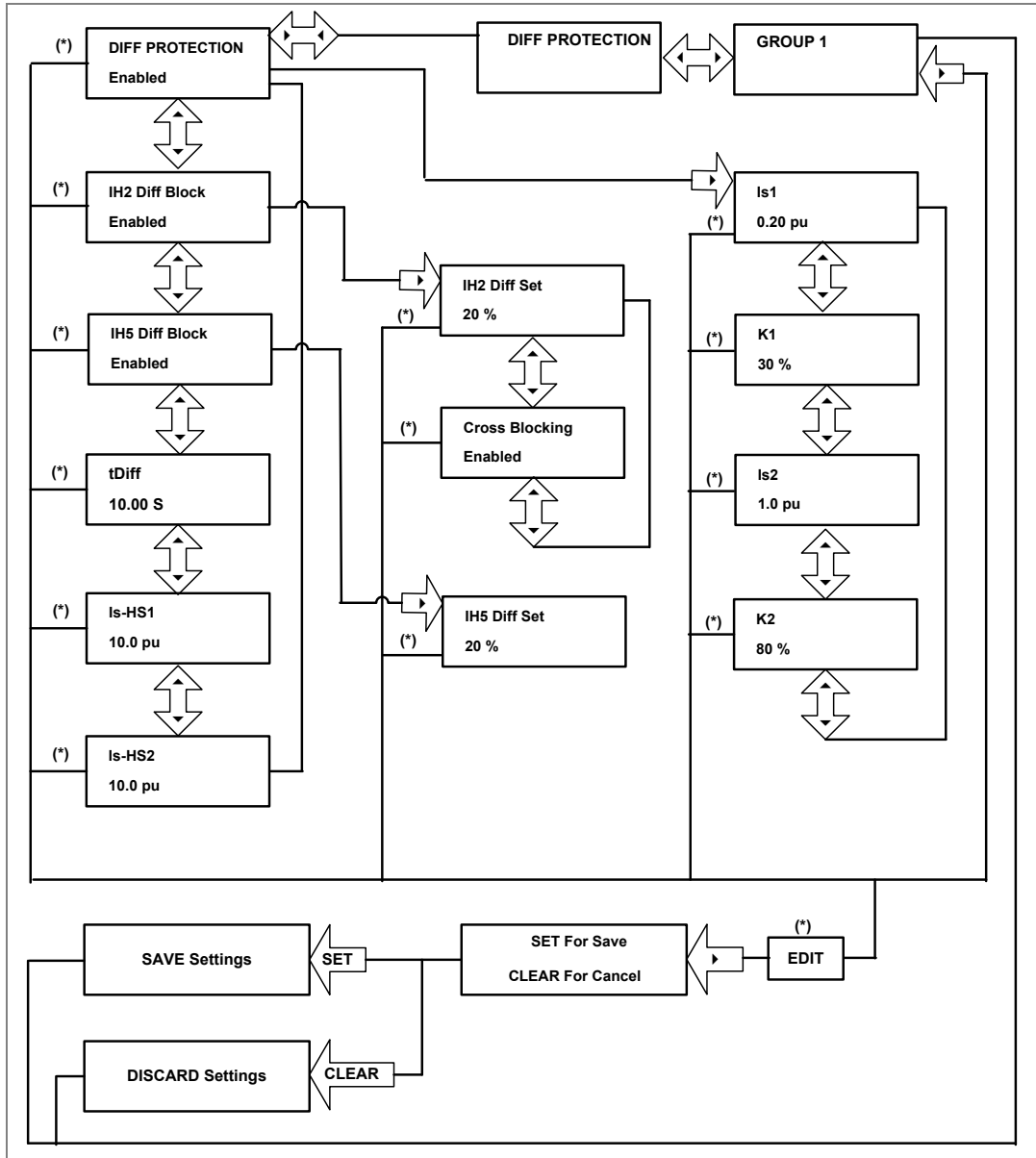

Note: (*) indicates **EDIT** key used to modify settings. Refer to the View and Edit settings section.

2.4.19 Group1 REF PROTECTION submenu

2.4.19.1.1 View/edit settings (If the setting is disabled)

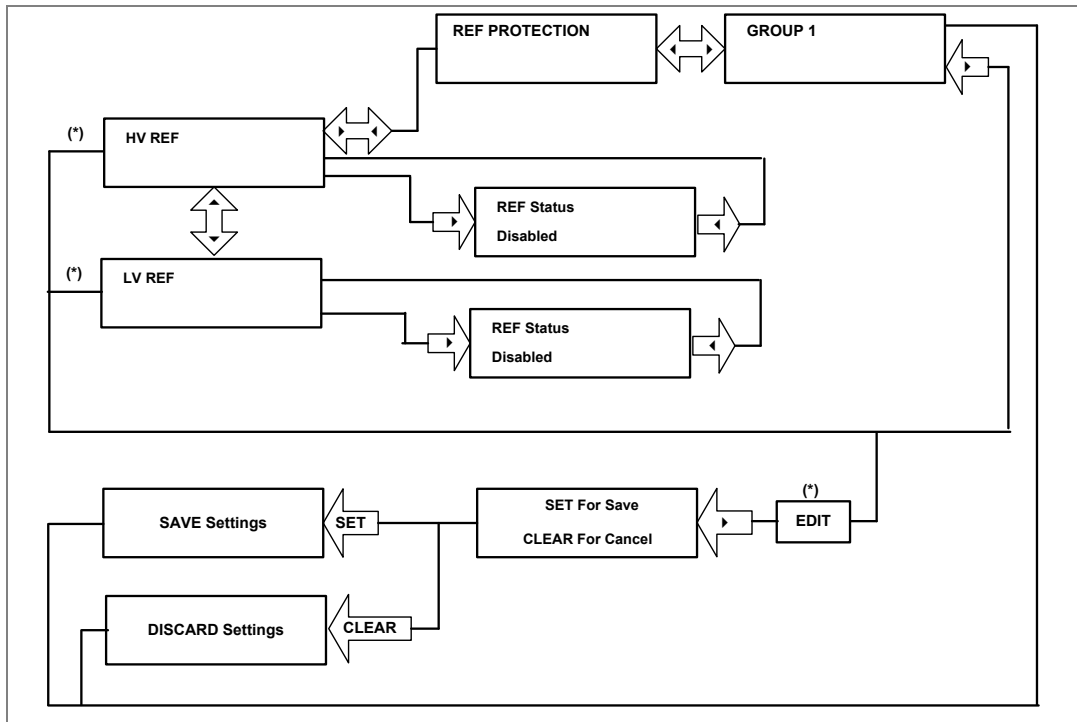

Note: (*) indicates **EDIT** key used to modify settings. Refer to the View and Edit settings section.

2.4.19.1.2 View/edit settings (If the setting is enabled)

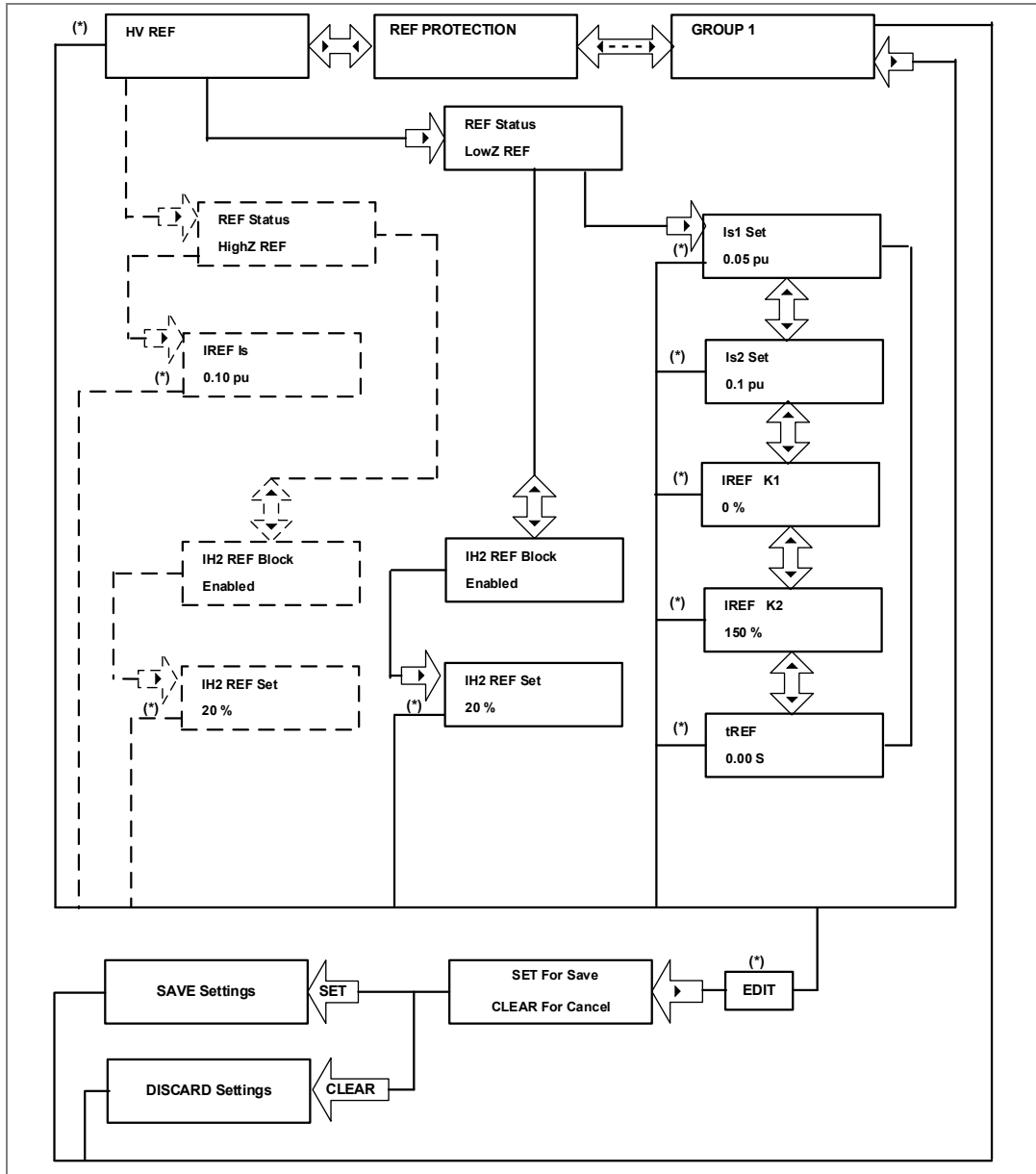

Note: (*) indicates **EDIT** key used to modify settings. Refer to the View and Edit settings section.

2.4.19.2 View/edit settings (If LV REF Protection setting is enabled)

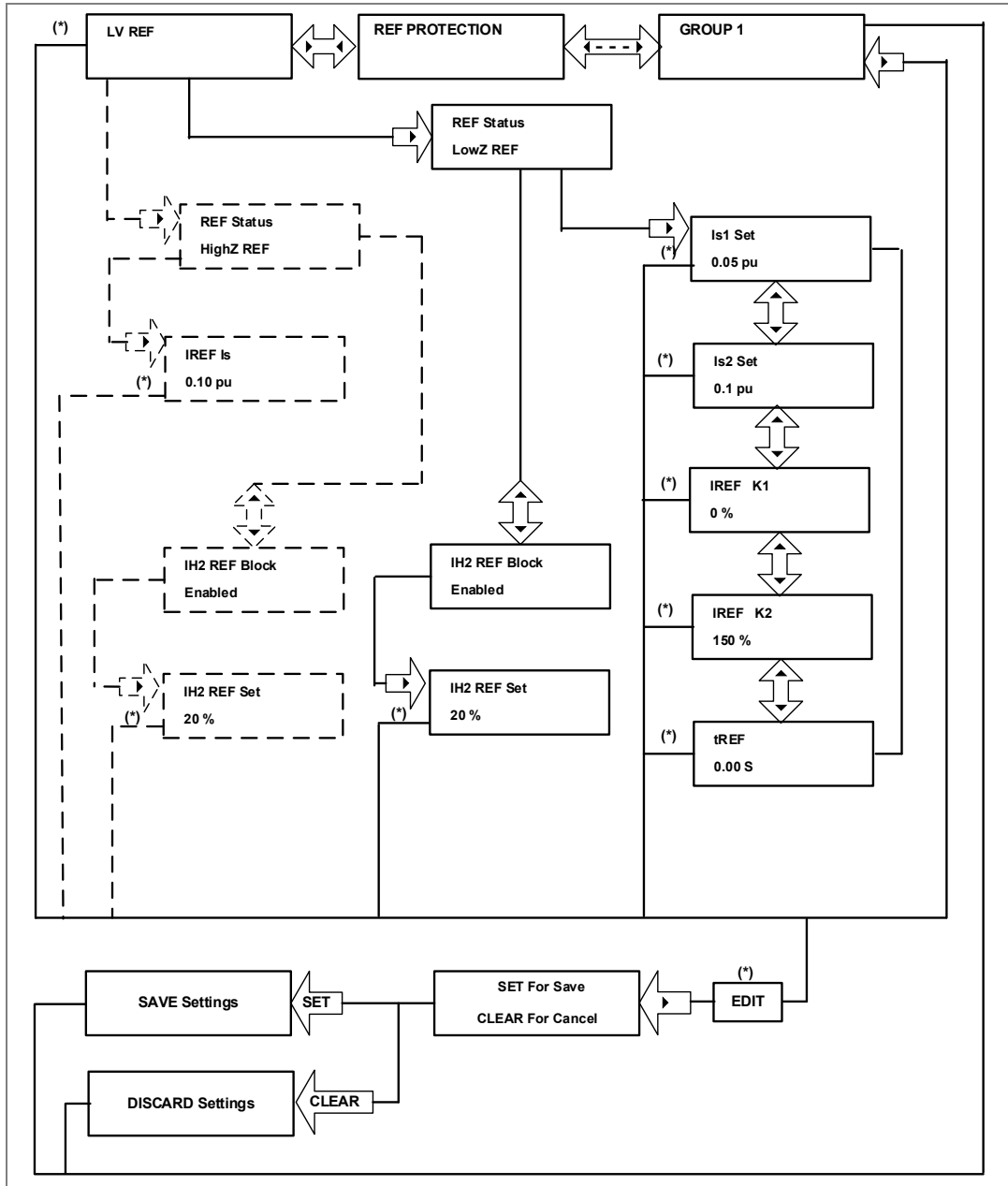

Note: (*) indicates **EDIT** key used to modify settings. Refer to the View and Edit settings section.

2.4.19.3 Group1 Overcurrent submenu

2.4.19.3.1 View/edit settings (If the setting is disabled)

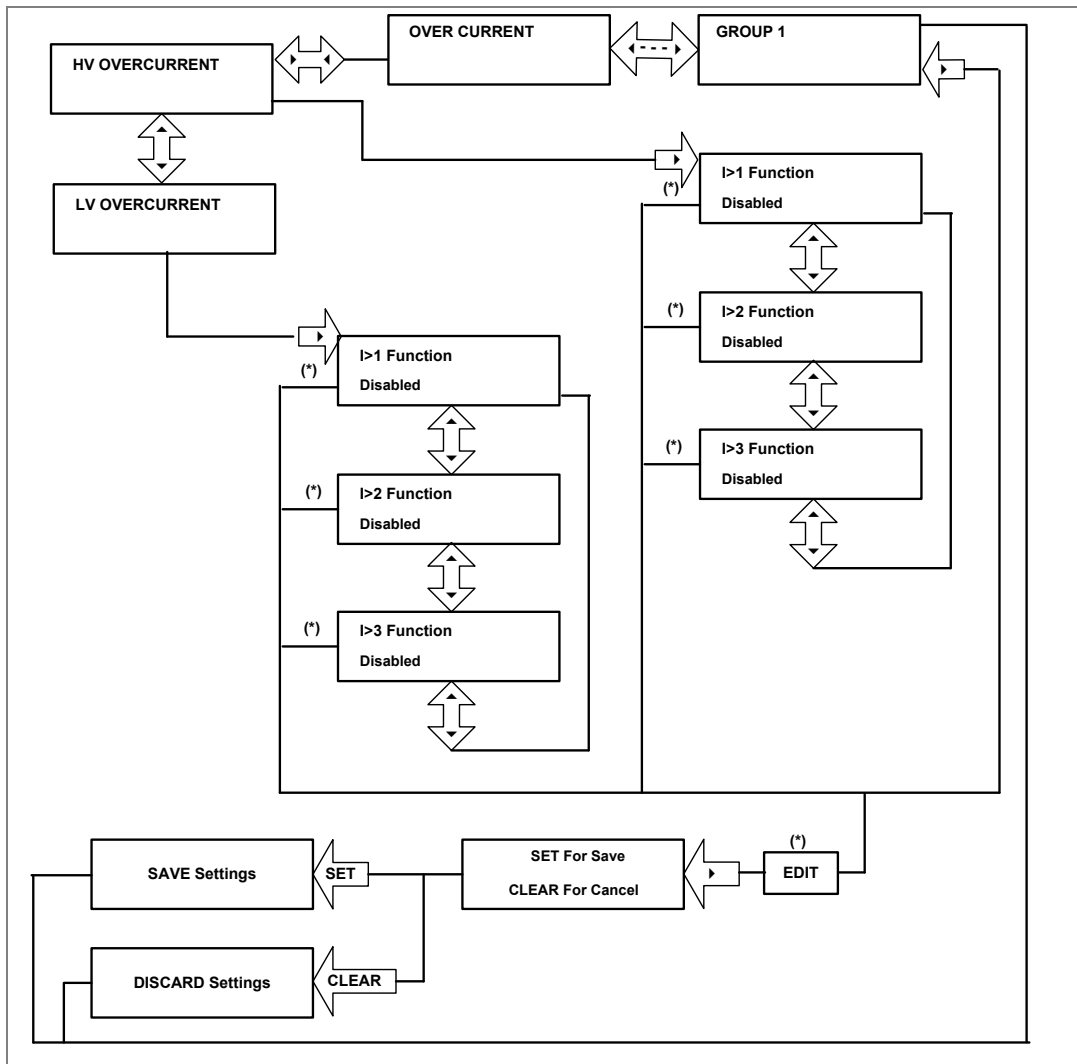

Note: (*) indicates **EDIT** key used to modify settings. Refer to the View and Edit settings section.

2.4.19.3.2 View/edit settings- HV Overcurrent (For all types of IEC curves)

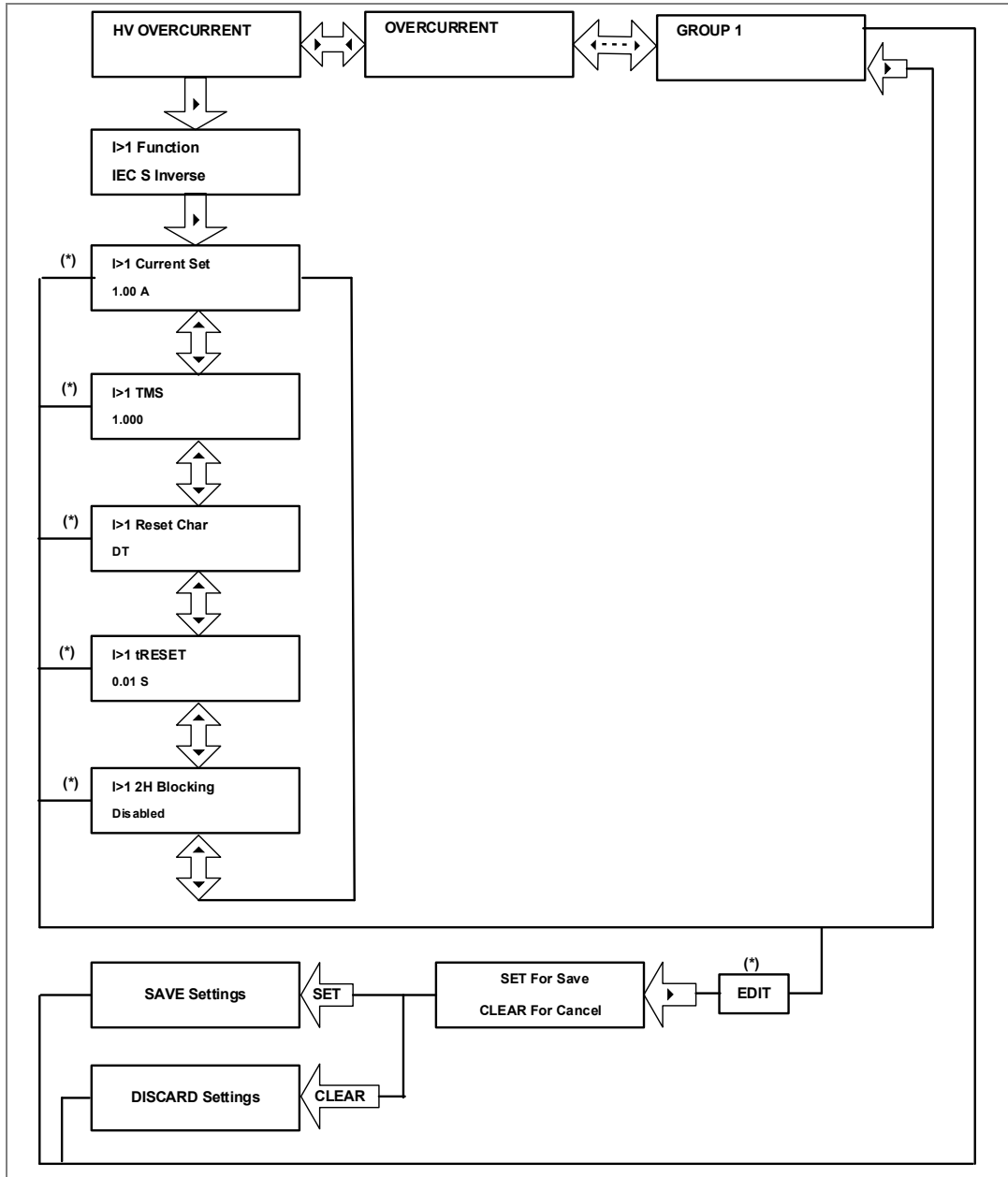

Note: (*) indicates **EDIT** key used to modify settings. Refer to the View and Edit settings section.

2.4.19.3.3 View/edit settings- HV Overcurrent (For all types of IEEE curves)

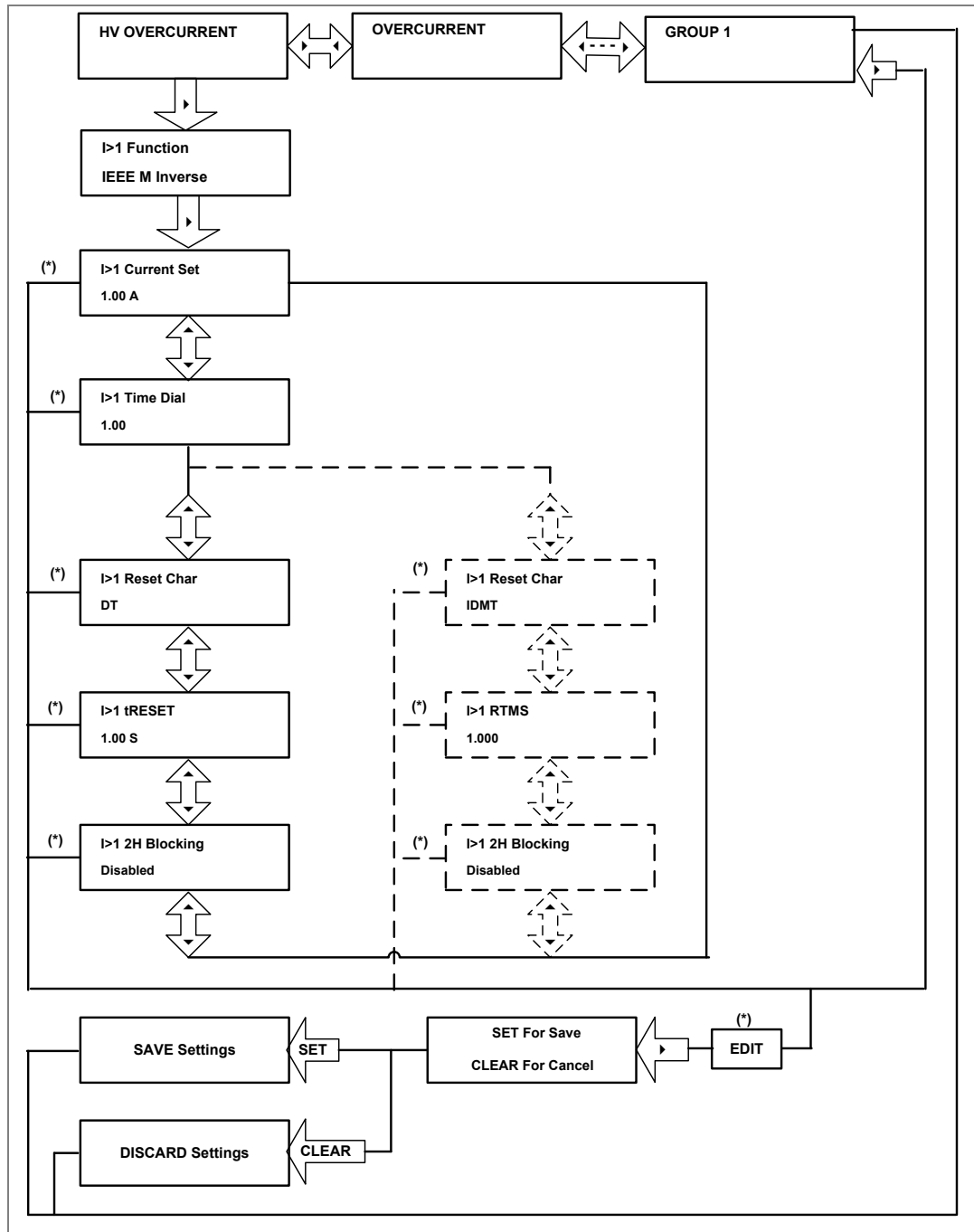

Note: The display windows shown in dashed lines will be seen if the **I>1 Reset Char** is selected as IDMT.

(*) indicates **EDIT** key used to modify settings. Refer to the View and Edit settings section.

2.4.19.3.4 View/edit settings- HV Overcurrent (For DT)

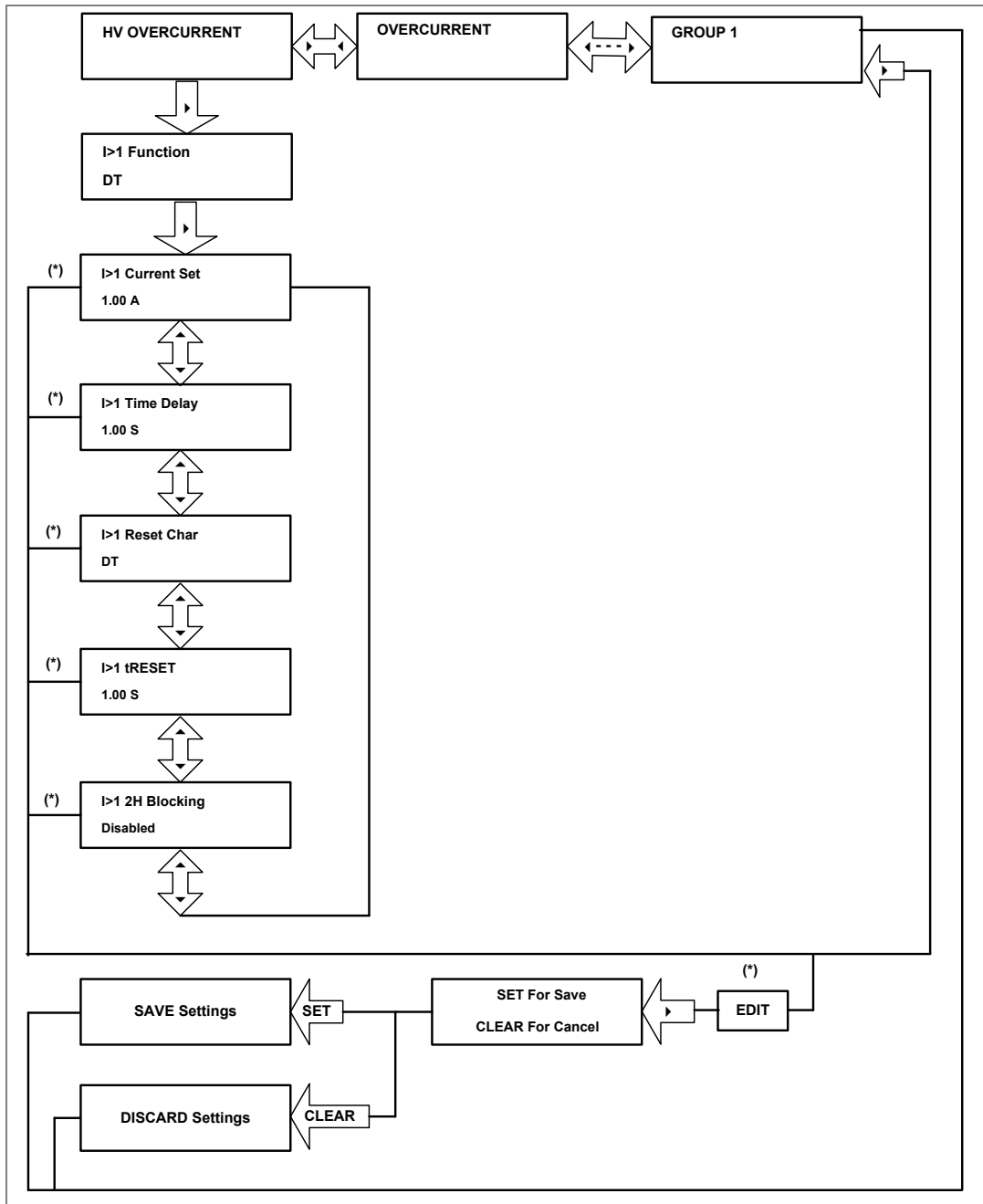

Note: (*) indicates **EDIT** key used to modify settings. Refer to the View and Edit settings section.
 LV Overcurrent function can be set in similar manner as HV Overcurrent function.

2.4.20 Negative Sequence Overcurrent menu

2.4.20.1 View/edit settings (If setting is disabled)

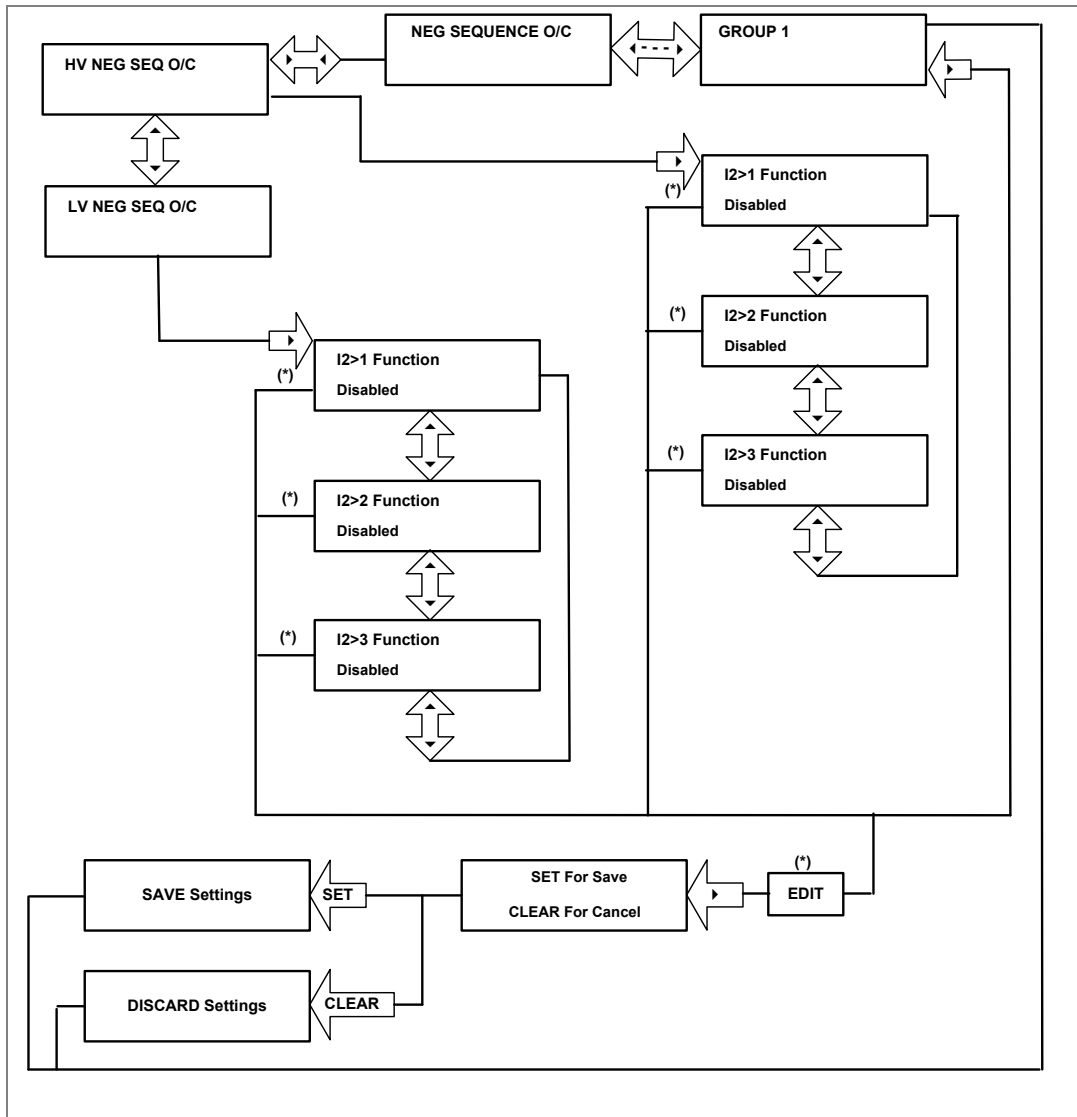

Note: (*) indicates **EDIT** key used to modify settings. Refer to the View and Edit settings section.

2.4.20.2 View/edit settings- HV NEG SEQ O/C (If setting is enabled for IEC curve)

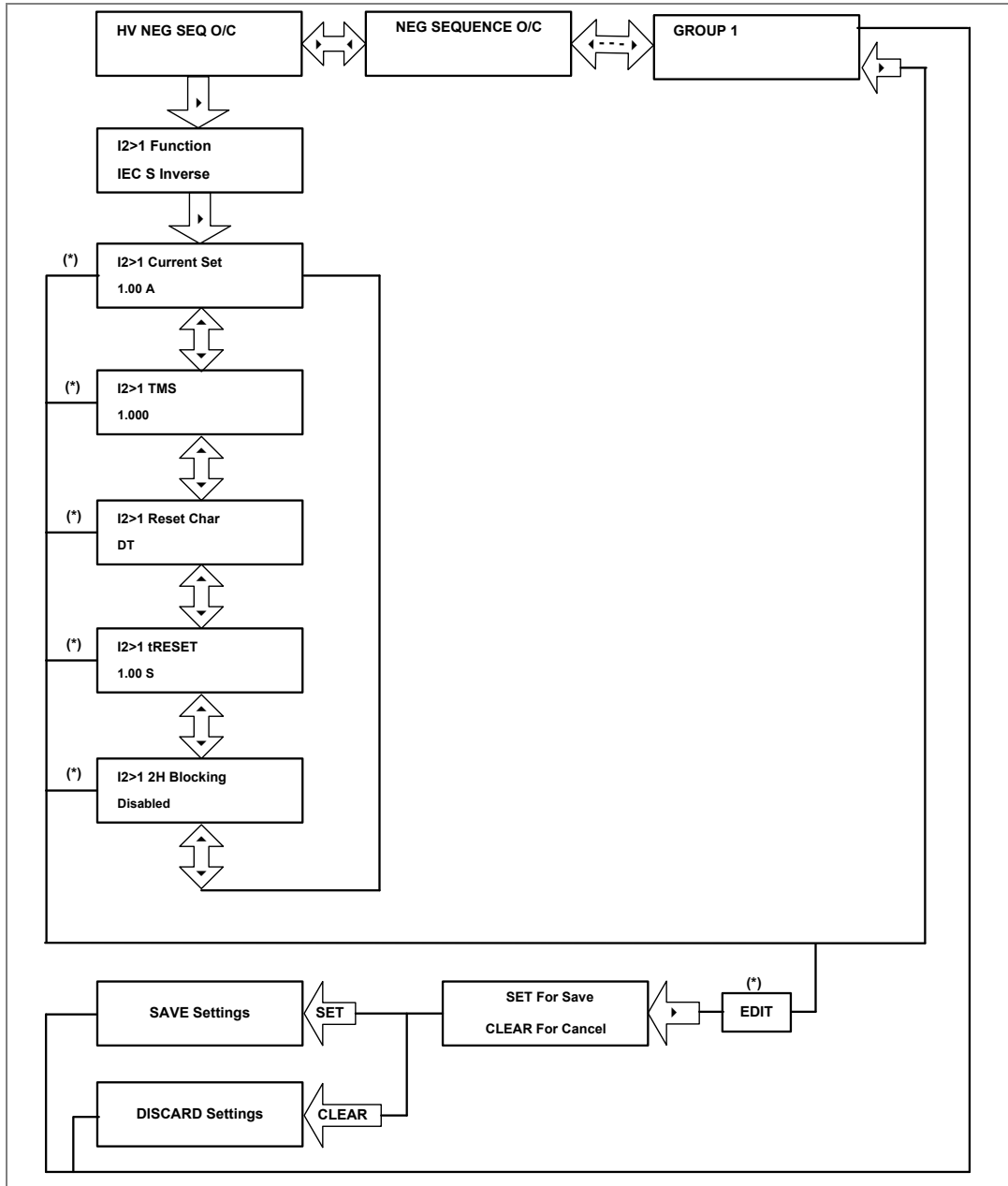

Note: (*) indicates **EDIT** key used to modify settings. Refer to the View and Edit settings section.

2.4.20.3 View/edit settings- HV NEG SEQ O/C (If setting is enabled for IEEE curve)

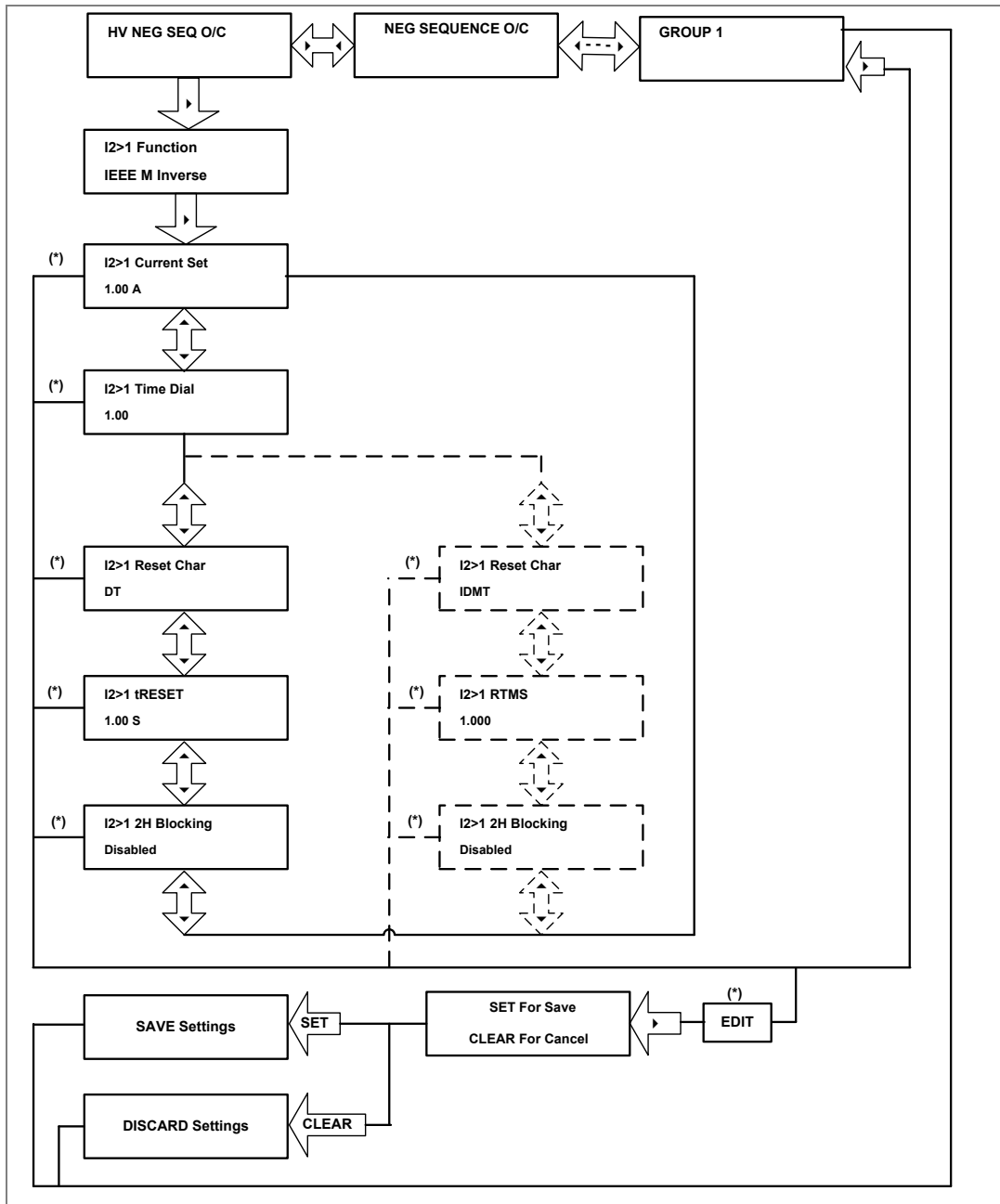

Note: The display windows shown in dashed lines will be seen if the I2>1 Reset Char is selected as IDMT.

(*) indicates **EDIT** key used to modify settings. Refer to the View and Edit settings section.

2.4.20.4 View/edit settings- HV NEG SEQ O/C (If setting is enabled for DT)

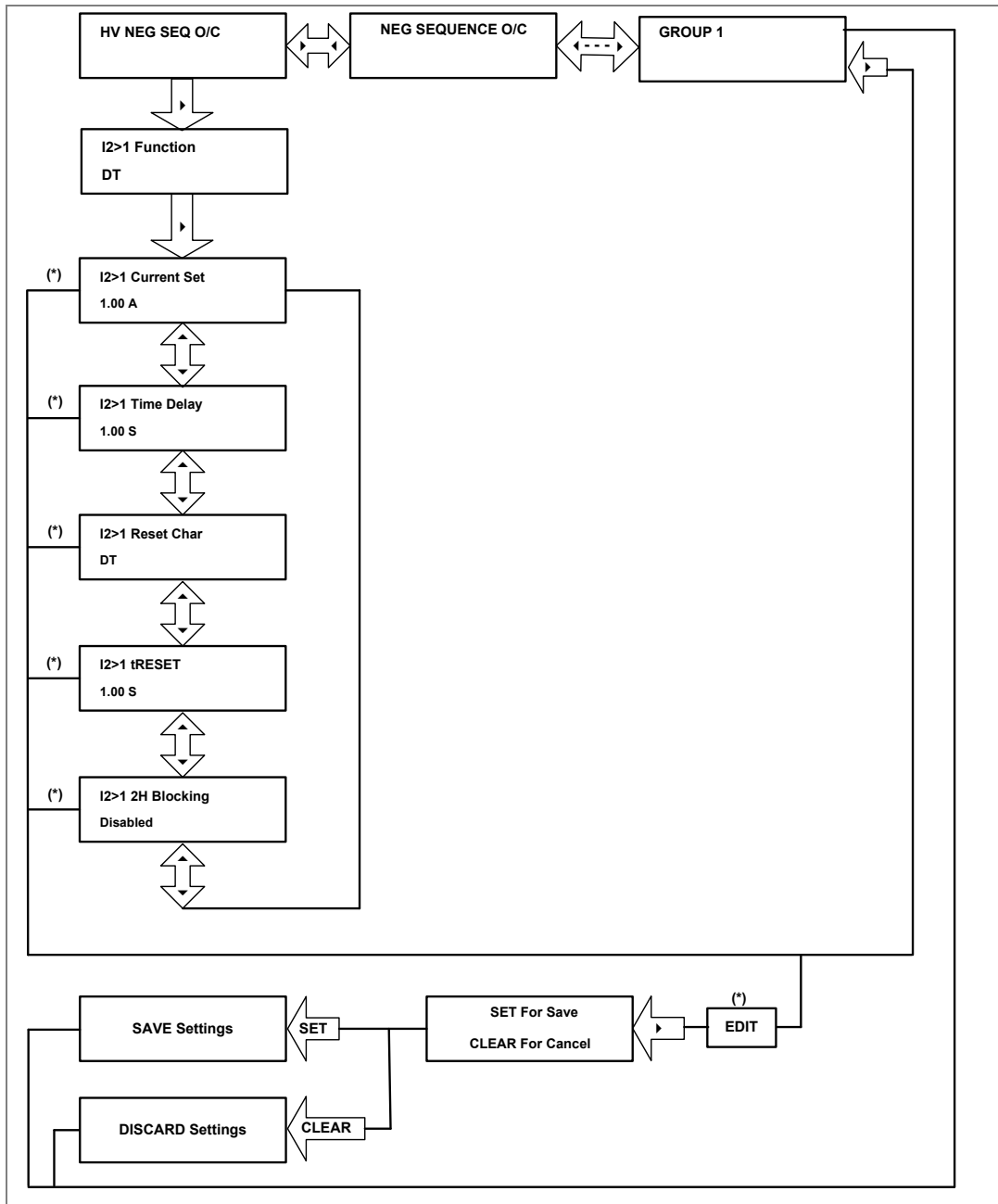

Note: (*) indicates **EDIT** key used to modify settings. Refer to the View and Edit settings section.
 LV NEG SEQ O/C function can be set in similar manner as HV NEG SEQ O/C function.

2.4.21 Group 1- Earth Fault submenu

2.4.21.1 View/edit settings- HV Earth Fault (If setting is disabled)

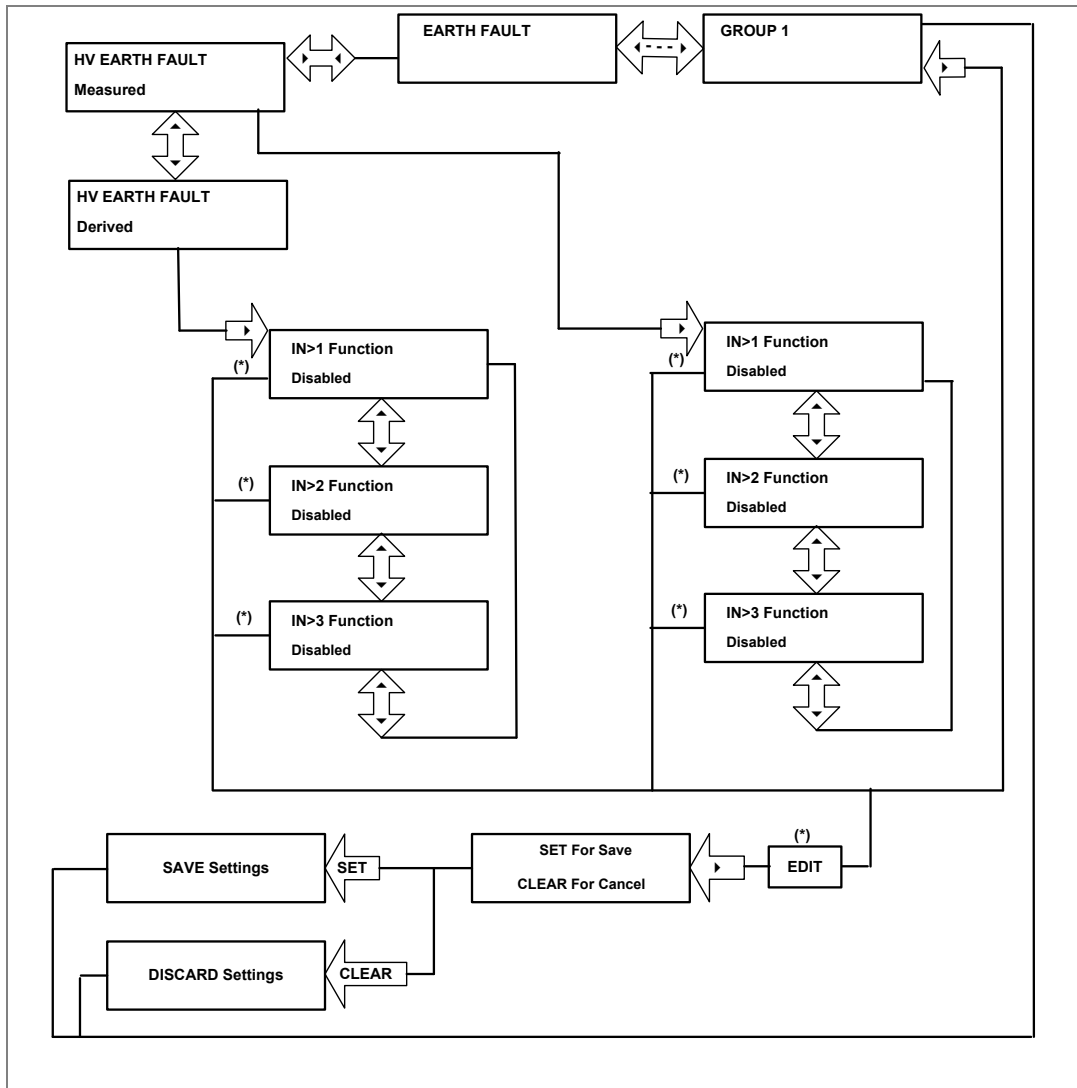

Note: (*) indicates **EDIT** key used to modify settings. Refer to the View and Edit settings section.

2.4.21.2 View/edit settings- HV Earth Fault (If setting is enabled for IEC curve)

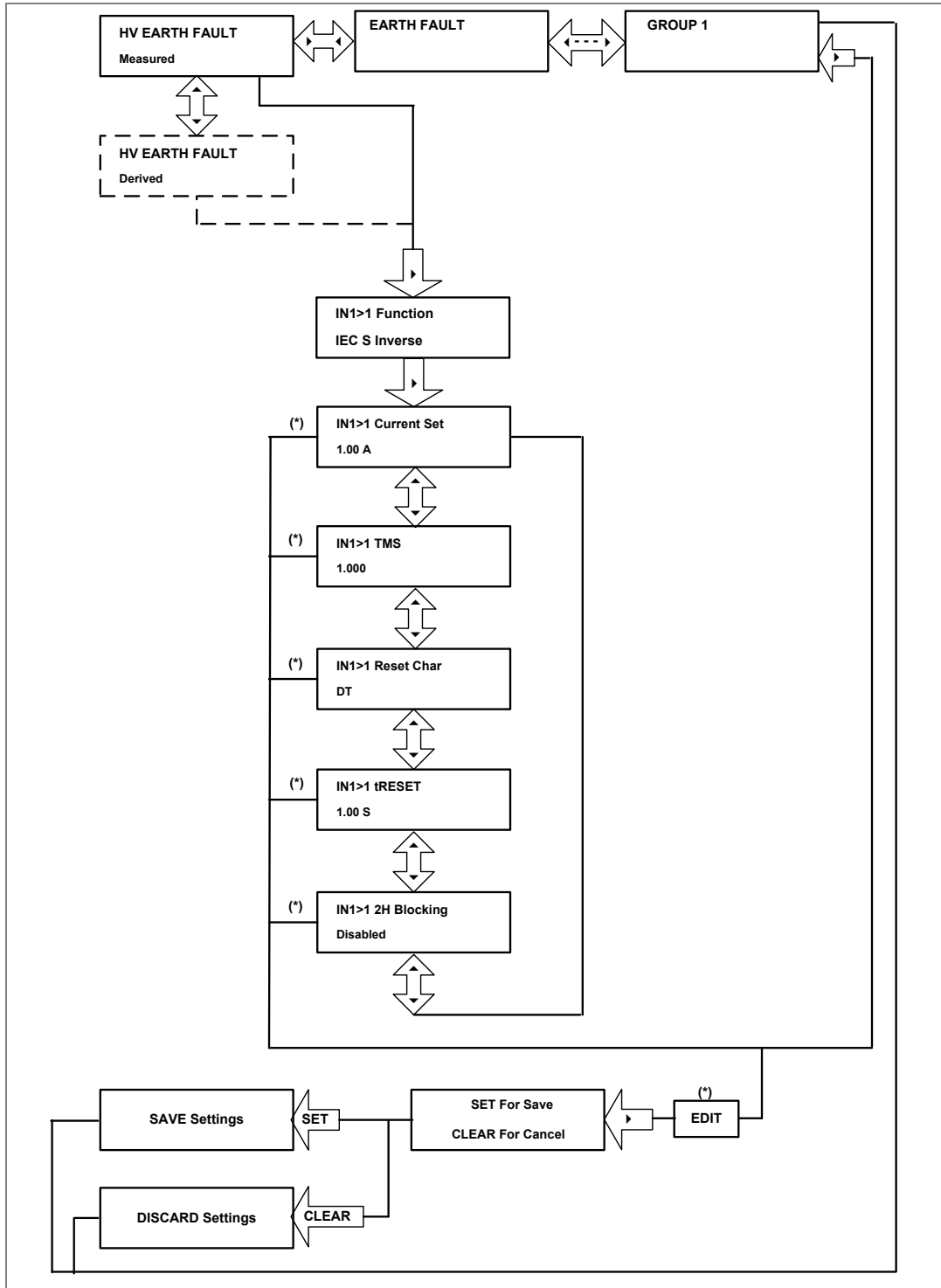

Note: (*) indicates **EDIT** key used to modify settings. Refer to the View and Edit settings section.

2.4.21.3 View/edit settings- HV Earth Fault (If setting is enabled for IEEE curve)

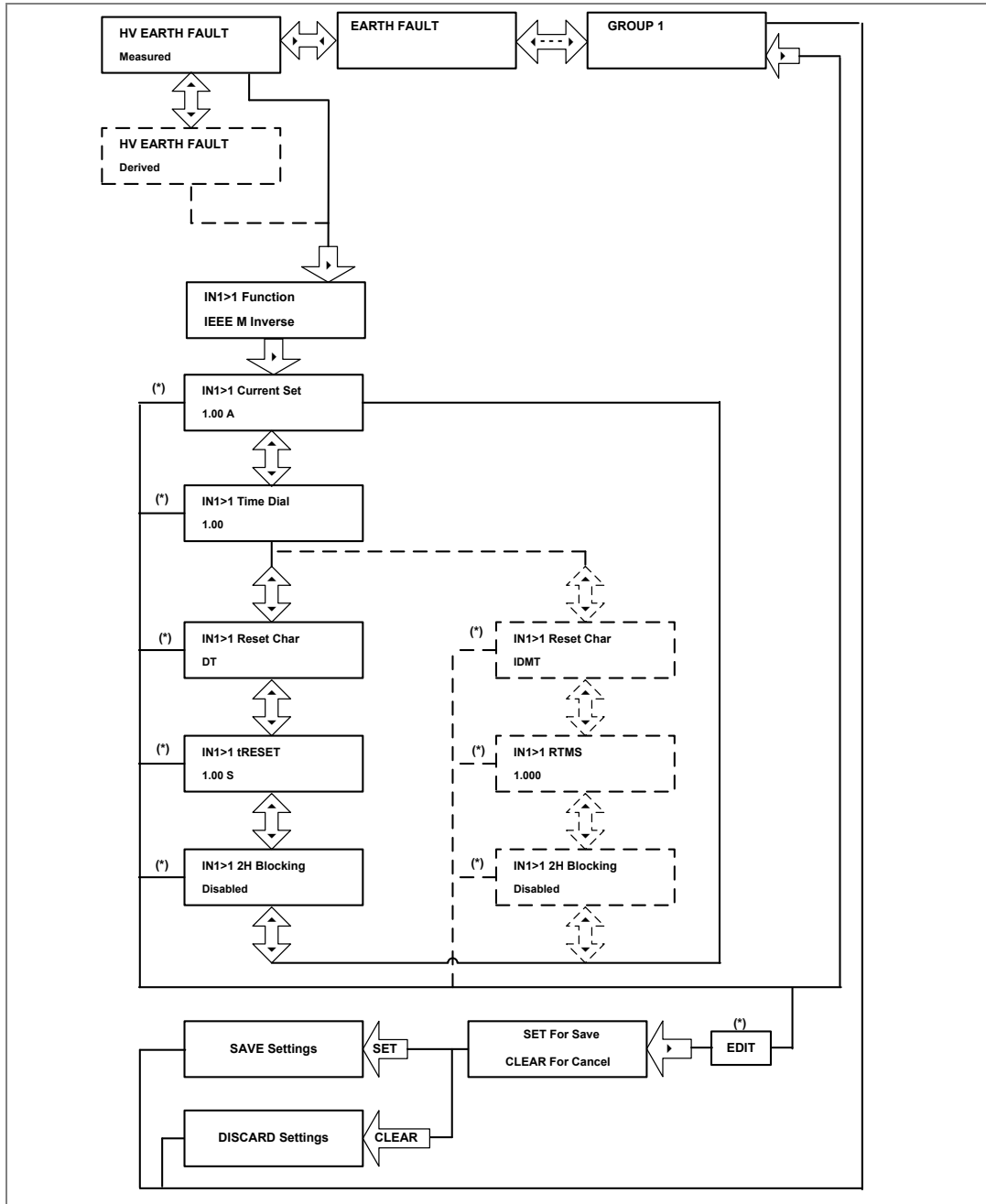

Note: The display windows shown in dashed lines will be seen if the *IN1>1 Reset Char* is selected as *IDMT*.

(*) indicates **EDIT** key used to modify settings. Refer to the *View and Edit settings* section.

2.4.21.4 View/edit settings- HV Earth Fault (If setting is enabled for DT)

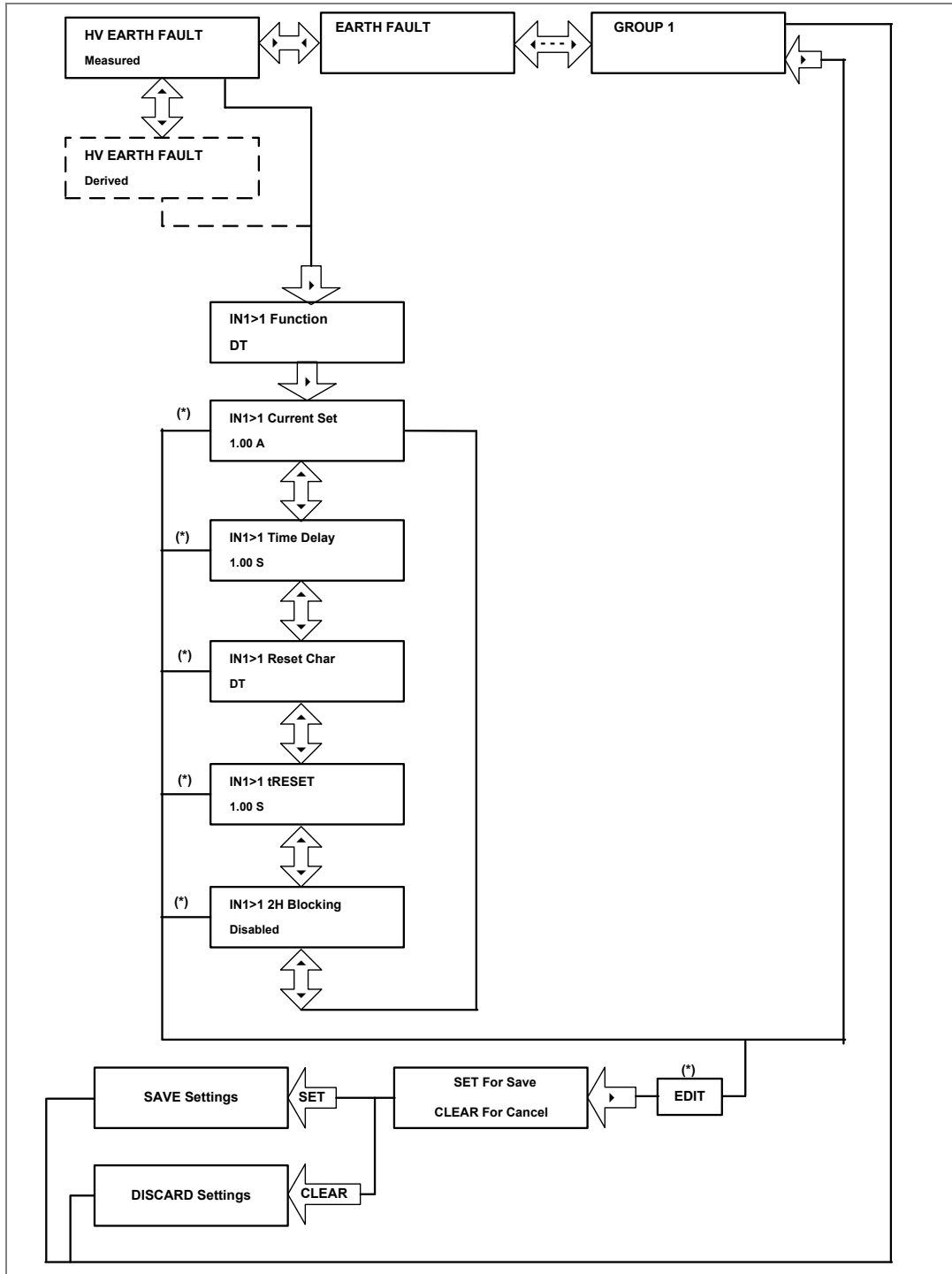

Note: (*) indicates **EDIT** key used to modify settings. Refer to the View and Edit settings section.

LV Earth Fault function can be set in similar manner as HV Earth Fault.

2.4.22 Group 1-Thermal Overload submenu

2.4.22.1 View/edit settings (If Characteristics is disabled)

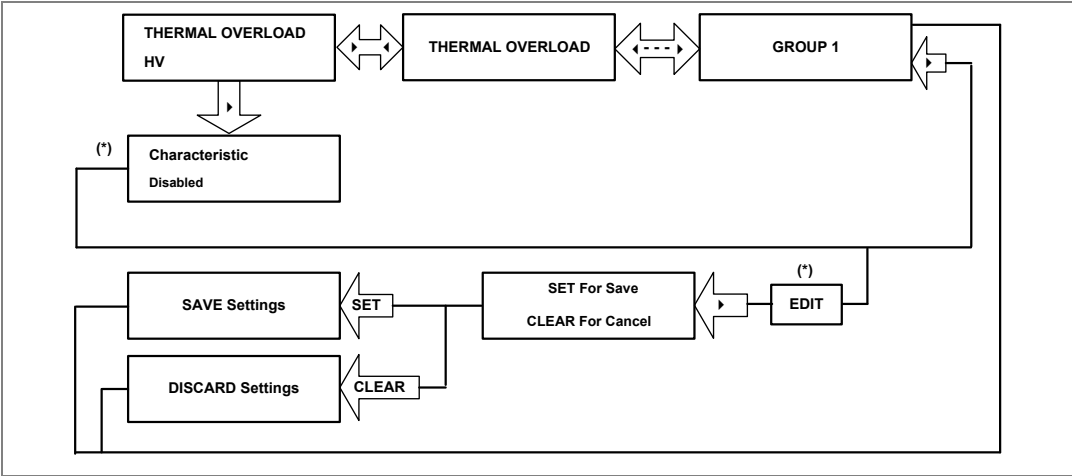

Note: (*) indicates **EDIT** key used to modify settings. Refer to the View and Edit settings section.

2.4.22.2 View/edit settings (If Characteristics is set as Single)

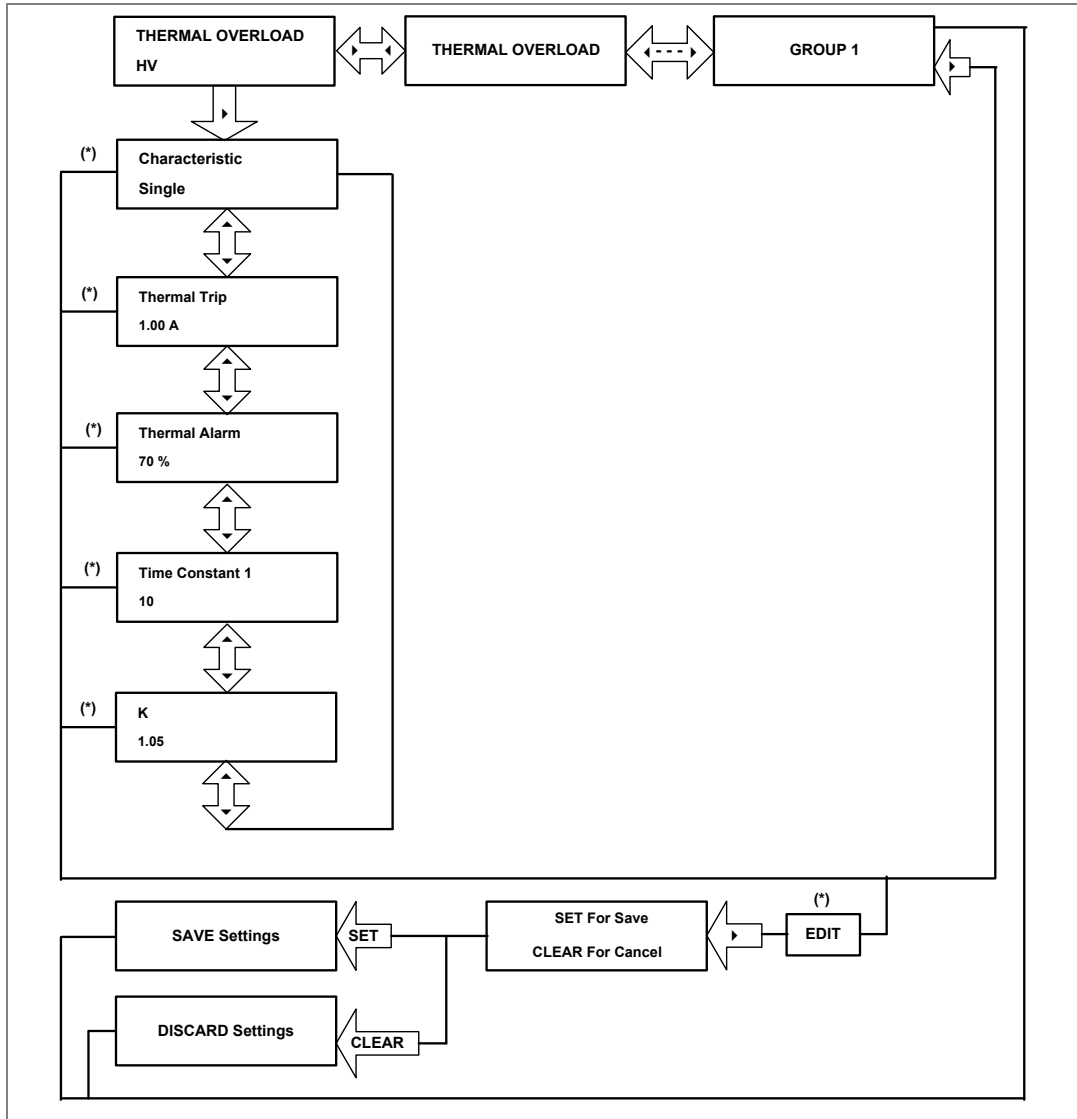

Note: (*) indicates **EDIT** key used to modify settings. Refer to the View and Edit settings section.

Thermal overload for LV can be set in similar manner as Thermal overload HV function.

2.4.23 Group 1-CB Fail submenu

2.4.23.1 View/edit settings- HV CB FAIL

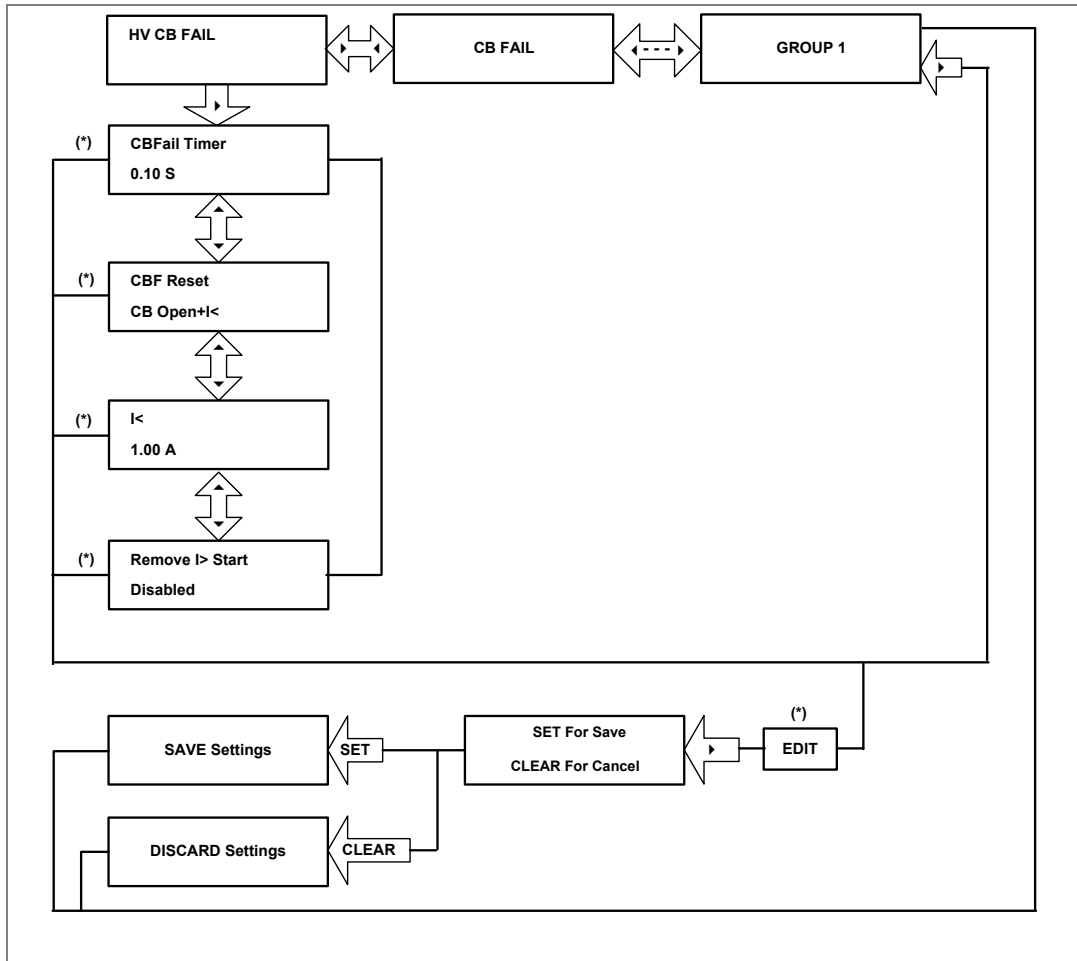

Note: (*) indicates **EDIT** key used to modify settings. Refer to the View and Edit settings section.

LV CB Fail settings can be done in similar manner as HV CB Fail settings

2.4.24 Group 1- Through Fault submenu

2.4.24.1 View/edit Settings (If function is enabled)

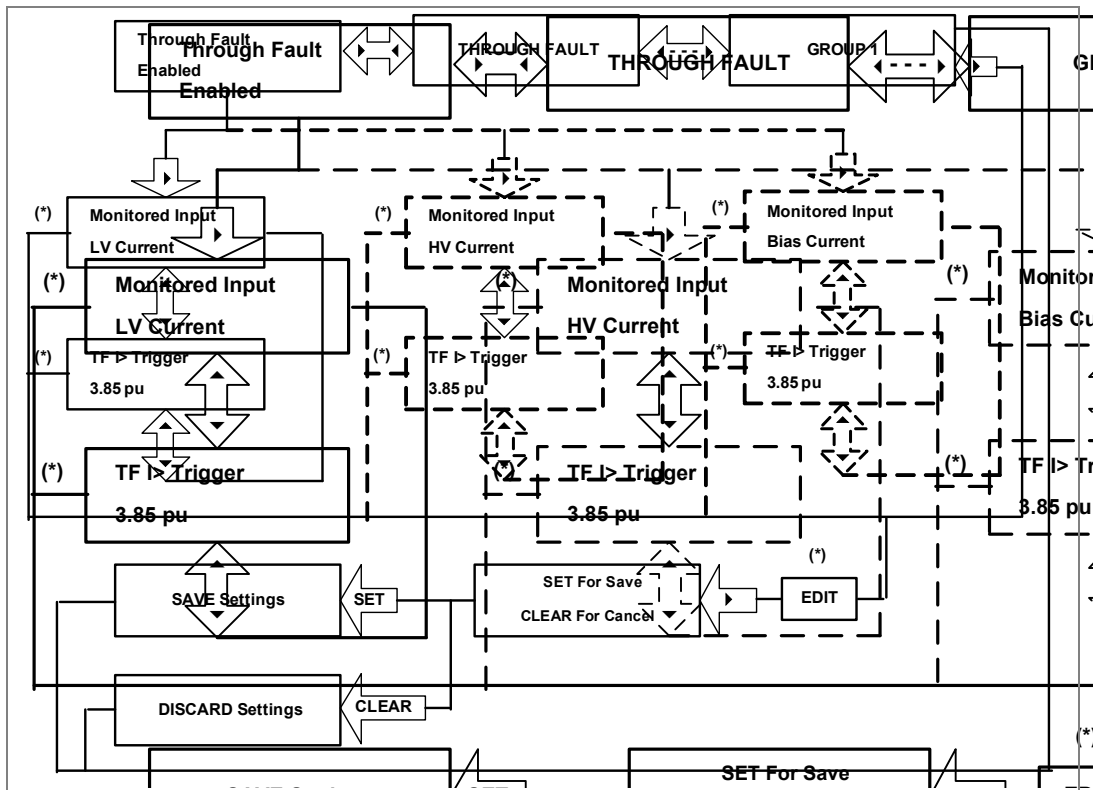

Note: (*) indicates **EDIT** key used to modify settings. Refer to the View and Edit settings section.

2.4.25 Group 2 menu

2.4.25.1 View/edit settings

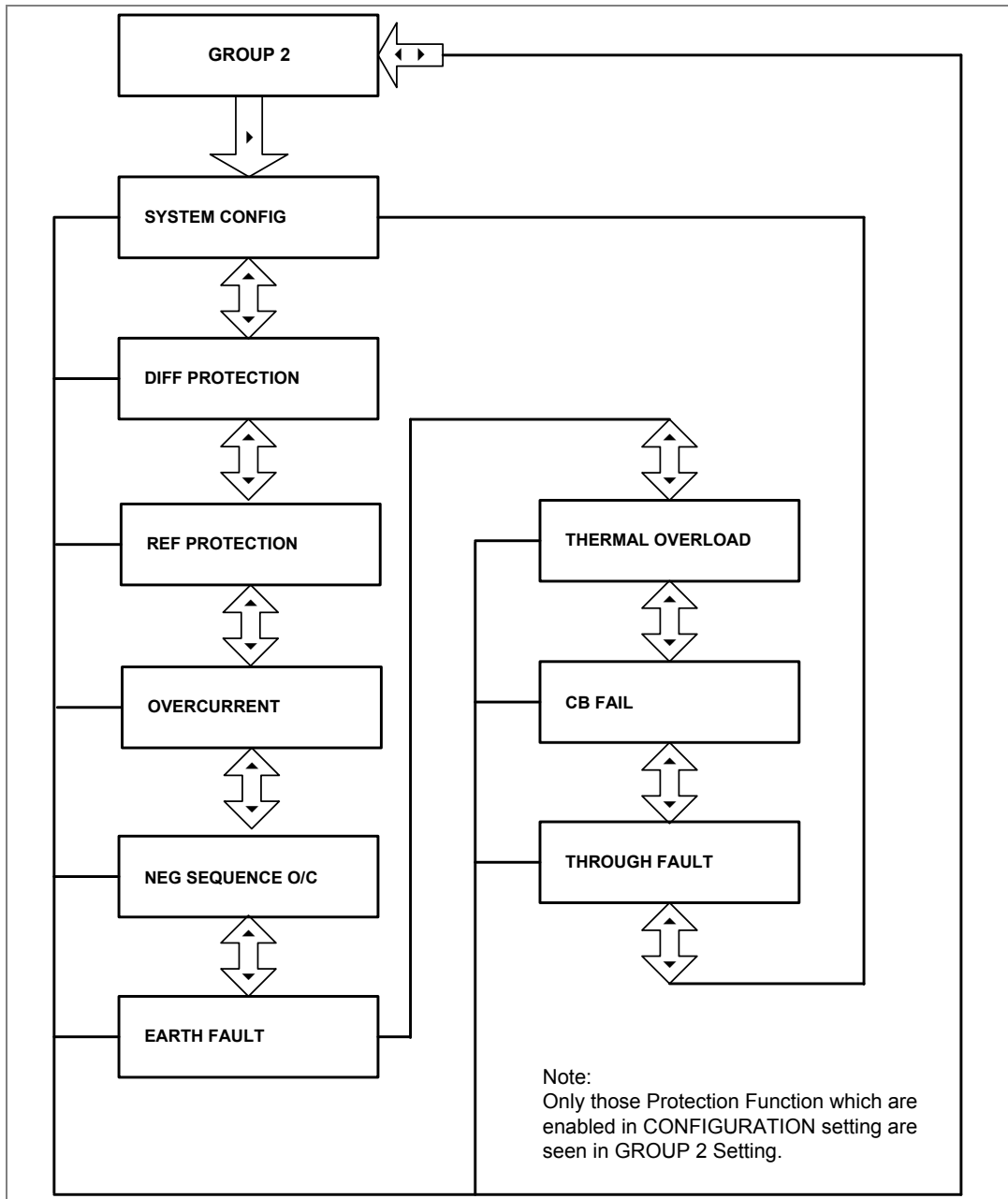

PROTECTION FUNCTIONS

CHAPTER 6

1 CHAPTER OVERVIEW

This chapter consists of the following sections:

1	Chapter Overview
2	Protection functions
2.1	Transformer Differential Protection principles
2.2	Through fault stability
2.3	Bias current compensation
2.4	Three-phase transformer connection types
2.5	Phase and amplitude compensation
2.6	Zero sequence filtering
2.7	Magnetising inrush restraint
2.8	Overfluxing restraint
2.9	Differential implementation
2.9.1	Defining the transformer
2.9.2	Amplitude compensation
2.9.3	Phase compensation
2.9.4	Setting zero sequence filtering
2.9.5	Transformer Differential operating characteristics
2.9.5.1	High set functions
2.9.5.2	5th harmonic blocking
2.9.5.3	2nd harmonic blocking
2.10	Overcurrent protection principles (HV and LV)
2.10.1	IDMT characteristics
2.10.2	Principle of protection function implementation
2.10.3	Timer hold facility/reset characteristics
2.11	Phase overcurrent protection
2.11.1	Phase Overcurrent Protection implementation
2.12	Negative sequence overcurrent protection (HV and LV)
2.12.1	Negative sequence overcurrent protection implementation
2.12.2	Negative sequence overcurrent protection logic
2.13	Earth fault protection (HV and LV)
2.13.1	Earth fault protection elements
2.13.2	Earth Fault protection logic
2.14	Restricted Earth Fault protection (HV and LV)
2.14.1	Restricted Earth Fault implementation
2.14.2	Application Note
2.14.2.1	Low impedance REF
2.14.2.2	High impedance REF
2.15	Thermal Overload function
2.15.1	Thermal Overload protection implementation
2.16	Circuit Breaker Fail protection (HV and LV)
2.16.1	Circuit Breaker Fail implementation
2.16.2	Circuit Breaker Fail logic (HV and LV)
2.17	Inrush current blocking function (2ND Harm Blocking)
2.17.1	Second harmonic blocking implementation (HV and LV)
2.18	Through fault function

2 PROTECTION FUNCTIONS

2.1 Transformer Differential Protection principles

Transformer Differential Protection (87T) uses the well-known current differential principle where current entering the protected equipment is compared with the current leaving the protected equipment. If there is no fault, the current entering the transformer will be equal to the current leaving the transformer multiplied by the inverse of the turns ratio. If there is a fault in the transformer zone, the currents will not be equal, which results in a differential current. This differential current is proportional to the fault current for internal faults, but approaches zero for any other operating conditions. The IED trips the circuit breakers protecting the transformer when it detects a minimum level of differential current.

The differential scheme creates a well-defined protection zone between the CT sets protecting the transformer. Any fault within the differential protection zone is called an internal fault, while any fault outside the differential protection zone is called an external fault. The protection should operate only for internal faults and be sensitive to low fault currents. It should also restrain on the highest prospective external faults, providing the CTS accurately reproduce the primary currents. This is difficult to achieve in practice because the CTs never have identical saturation characteristics. This will result in a differential current, which could cause undesirable operation.

An external fault, which causes a high current to flow through the transformer, is called a through fault. The through-fault current will usually be high enough to saturate the CTs. The differences in the saturation characteristics of the CTs will cause a differential current, which could cause the device to trip unless it is restrained. The term used to specify the IED's ability to cope with these imperfections is called Through Fault Stability.

CT saturation is not the only cause of undesirable differential current. Other aspects which need to be considered by the transformer differential element to avoid maloperation are:

- Phase shift between the transformer primary and secondary currents depending on the vector group
- Transformation ratio
- The zero-sequence current, which flows in the grounded star transformer winding or the grounding transformer within the differential protection zone
- Tap changer operation to adjust the voltage
- Magnetising inrush current that flows immediately after the transformer energisation or during a voltage recovery after the clearance of an external fault or when a second transformer is paralleled with the already energised transformer
- Over excitation of the transformer

2.2 Through fault stability

With any form of differential protection, it is important that the CTs have the same characteristics. This is to avoid unnecessarily creating a differential current. However, in reality CTs can never be identical; therefore a certain amount of differential current is inevitable. As the through-fault current in the primary increases, the discrepancies introduced by the imperfectly matched CTs are magnified, causing the differential current to build up. Eventually, the value of the differential current reaches the pickup current threshold, causing the IED to trip. In such cases, the differential scheme is said to have lost stability. To specify a differential scheme's ability to restrain from tripping on external faults, we define a parameter called 'through-fault stability limit', which is the maximum through-fault current a system can handle without losing stability.

2.3 Bias current compensation

To prevent maloperation, compensation is needed for the protection to remain sensitive to internal faults but to ignore through faults. This is achieved by applying a proportion of the scalar sum of all the currents entering and exiting the zone. This scalar sum is called bias current.

The bias characteristic changes the operating point of the IED depending on the fault current. At low through-fault currents, the CT performance is more reliable so a low bias current is needed. Less differential current is then needed to trip the circuit breakers, allowing greater sensitivity to internal faults. At high through-fault currents, the CTs may be close to saturation so a high bias current is needed. More differential current is then needed to trip the circuit breakers, allowing greater security from external faults and less risk of maloperation.

This is achieved by defining an operating current characteristic. Often a triple slope characteristic is used as shown below.

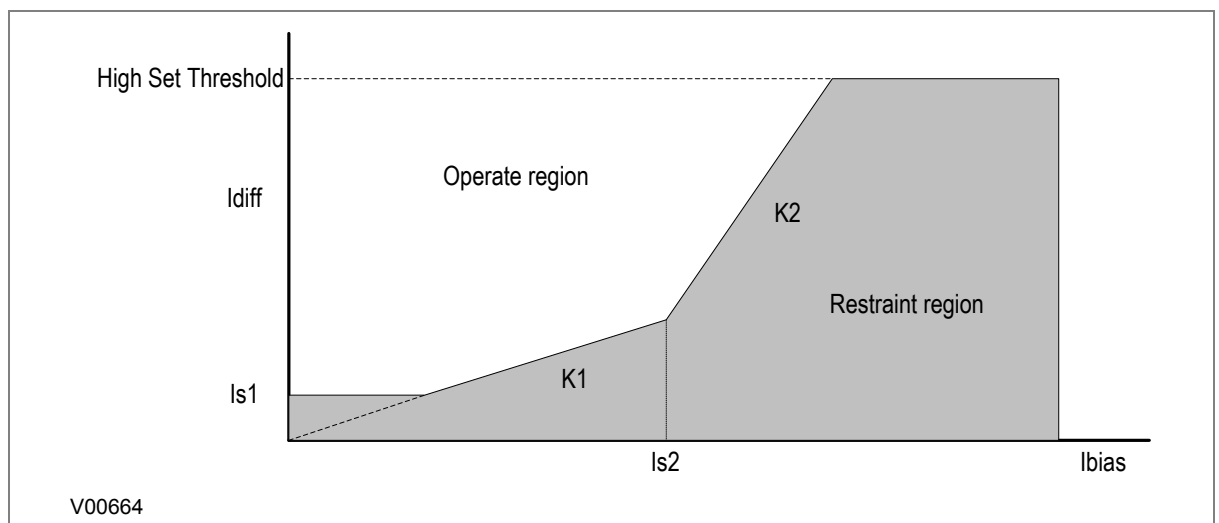

Figure 1: Compensation using biased differential characteristic

I_{diff} is the differential current, which is the vector sum of all the current inputs. I_{bias} is a current which is proportional to the scalar sum of all currents entering and leaving the zone. The bias current is used to calculate an operating current. If the differential current calculated by the IED is above the operation current, then the device will trip (providing no blocking signals are asserted).

The characteristic can be defined by setting certain parameters such as the minimum operating current I_{s1} , I_{s2} , $K1$ and $K2$. I_{s1} sets the minimum operating current. I_{s2} sets the level of bias current at which the steeper slope sets in. Constants $K1$ and $K2$ define the slopes. A High Set threshold is usually defined which ensures the device will operate for very high currents, even if blocking signals are present.

The slope parts of the characteristic curve provide stability for external faults that cause CT saturation. The high bias current region of the characteristic curve has a steeper slope than the low bias current region in order to improve the stability even further for high-current external faults. The first slope, $K1$, compensates for CT errors and tap changer errors. The second slope, $K2$, compensates for CT saturation. I_{s1} should be set above transient overfluxing and I_{s2} should be considered as the transformer full load current. The CTs are sized according to the transformer full load current.

2.4 Three-phase transformer connection types

There are two ways of connecting a three-phase transformer winding:

- Star-connected (sometimes known as Y, or Wye)
- Delta-connected (sometimes known as Δ or D)

In some transformers, the windings are split at the centre point and terminals are brought out so that they can also be interconnected. These windings can be zig-zag connected (Z-connected).

The more common connection types are:

- Y-y
- Y-d
- Y-z
- D-d
- D-y
- D-z

To differentiate between the low and high voltage sides of the transformer, a standard convention has been adopted whereby lower case is used for the low voltage side and upper case is used for the high voltage side.

Not only can the primary and secondary be connected as a star or a delta, each phase can also be reversed resulting in a large choice of possible connections. In reality, however, only a few of these are used, because we generally require that the phase shifts between the primary windings and their secondary counterparts be consistent. This reduces the common connection types to those shown in the table below.

You will notice that the naming convention specifying the connection type in the first column also has a number appended to it. This number, called the clock face vector, or vector group number represents the phase shift between the current in a low voltage winding with respect to its counterpart on the high voltage winding. This corresponds to the position of the number of a standard clock face. The table and diagram below shows examples of connections with the clock vectors Midnight, 1 o'clock, 6 o'clock and 11 o'clock, which is equivalent to a phase shift of 0°, -30°, -180° and +30° respectively.

Vector Group	Phase shift
Yy0	0°
Dd0	0°
Dz0	0°
Yd1	-30°
Dy1	-30°
Dz1	-30°
Yd5	-150°
Dy5	-150°
Dz5	-150°
Yy6	180°
Dd6	180°
Dz6	180°
Yd11	+30°
Dy11	+30°
Dz11a	+30°

Type	HV winding	LV winding	Winding Connection	Phase Shift
Yy0				0°
Dd0				0°
Dz0				0°
Yd1				-30°
Dy1				-30°
Yz1				-30°
Yd5				-150°
Dy5				-150°
Yz5				-150°

V03125

Figure 2: Transformer winding connections - part 1

Type	HV winding	LV winding	Winding Connection	Phase Shift
Yy6				180°
Dd6				180°
Dz6				180°
Yd11				30°
Dy11				30°
Yz11				30°

V03126

Figure 3: Transformer winding connections - part 2

2.5 Phase and amplitude compensation

A power transformer is designed to convert voltages. This means the line currents either side of the transformer are different in magnitude. If identical CTs were used on both sides of the transformer, the differential protection circuit would be unbalanced, causing a differential current. Obviously, this has to be compensated for. Amplitude compensation is theoretically arranged by having a suitable turns ratio on the secondary CT. Ideally, selecting CT ratios that exactly match the inverse of the transformer turns ratio would compensate for the difference in the transformer current magnitudes. However, the CT ratios associated with available CTs typically do not provide exact ratio matching. Also for Y-delta or delta-Y connected transformers, the voltage and current magnitudes used are changed by a factor of $\sqrt{3}$. Further, a phase shift is introduced, meaning the secondary side is out of phase with the primary side. So further amplitude compensation, as well as phase compensation is required.

Before the advent of numerical IEDs, this compensation was achieved by choosing CTs with appropriate turns ratios and connection types, and introducing interposing CTs with appropriate connection types. Of course, having CTs with different turns ratios and connection types on each side

of the protected zone exacerbates the CT errors, therefore increasing the need for good through-fault compensation.

With modern IEDs, it is possible to do a great deal of the compensation in software, so simple Y-connected CTs can be used on both sides of the transformer irrespective of the connection types. The CTs are chosen such that their respective turns ratios provide a nominal current usable by the IED (1A or 5A). This in itself provides a certain amount of amplitude compensation, but there will invariably be a CT ratio mismatch. This mismatch is compensated for by software in the IED. The device calculates suitable values based on the reference power rating, transformer voltage ratings, CT ratios and connection type (star or delta) to scale the secondary currents to a common base.

2.6 Zero sequence filtering

An earth fault in a three-phase system will always produce a zero sequence current component. With earthed Y-connected windings, this zero sequence current flows through the neutral conductor to earth. With delta-connected windings, this zero sequence current component just circulates around the delta connected windings (unless an earthing transformer is used). So in the case of a Y-delta transformer, an external fault will cause zero sequence current to be measured by the Y-side CTs. However, because this zero sequence current is trapped on the delta side, it is not measured by the delta-side CTs. This could cause maloperation if not compensated for. Before the advent of numerical IEDs, this was handled by a configuration involving interposing CTs. Numerical IEDs, however, can do this by filtering out the zero sequence components in software.

2.7 Magnetising inrush restraint

Whenever there is an abrupt change of magnetising voltage (e.g. when a transformer is initially connected to a source of AC voltage), there may be a substantial surge of current through the primary winding called inrush current.

In an ideal transformer, the magnetizing current would rise to approximately twice its normal peak value as well, generating the necessary MMF to create this higher-than-normal flux. However, most transformers are not designed with enough of a margin between normal flux peaks and the saturation limits to avoid saturating in a condition like this, and so the core will almost certainly saturate during this first half-cycle of voltage. During saturation, disproportionate amounts of MMF are needed to generate magnetic flux. This means that winding current, which creates the MMF to cause flux in the core, could rise to a value way in excess of its steady state peak value. Furthermore, if the transformer happens to have some residual magnetism in its core at the moment of connection to the source, the problem could be further exacerbated.

The following figure shows the magnetizing inrush phenomenon:

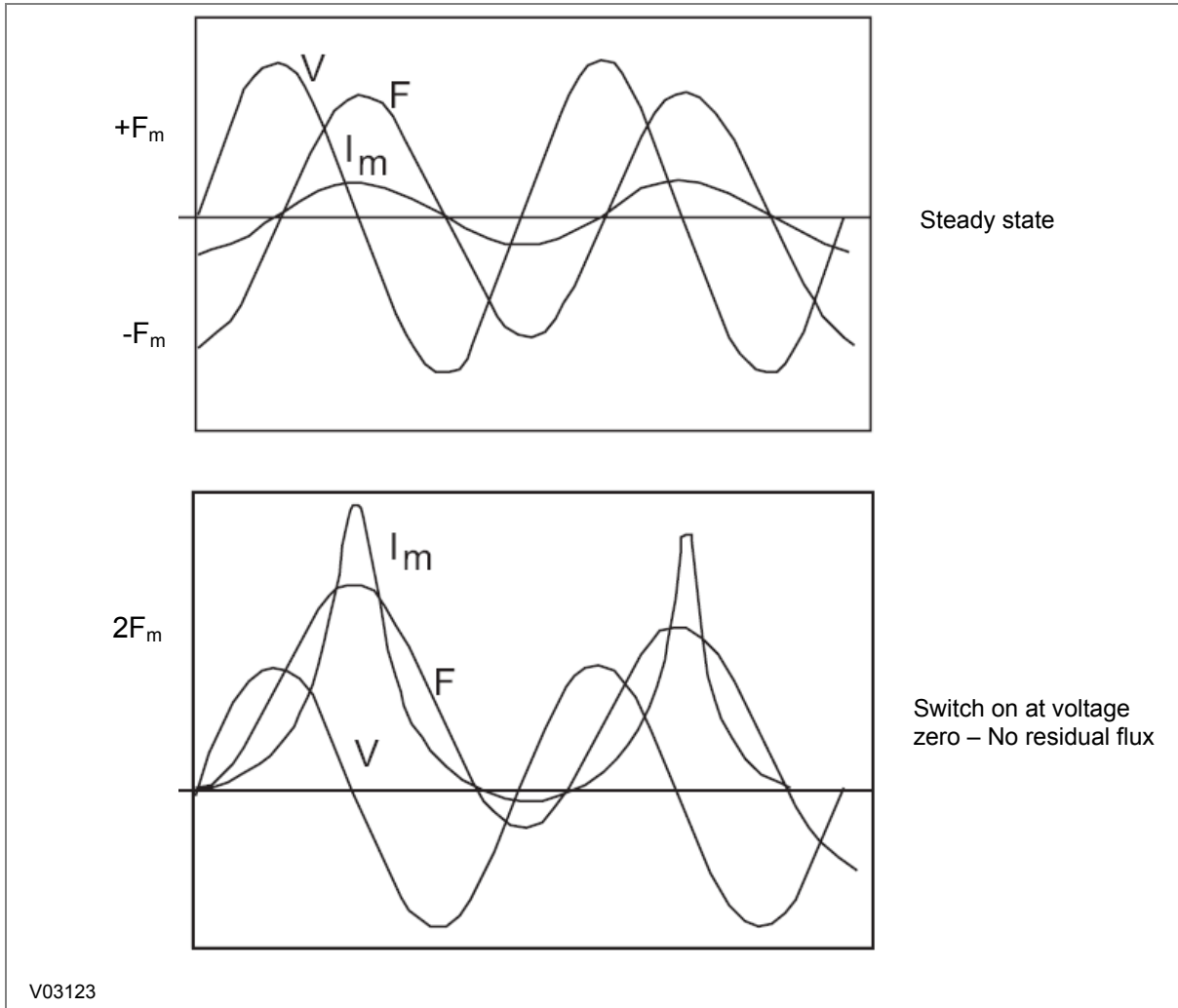

Figure 4: Magnetising inrush phenomenon

The main characteristics of magnetising inrush currents are:

- Higher magnitude than the transformer rated current magnitude
- Containing harmonics and DC offset
- Much longer time constant than that of the DC offset component of fault current

We can see that inrush current is a regularly occurring phenomenon and should not be considered a fault, as we do not wish the protection device to issue a trip command whenever a transformer is switched on at an inconvenient point during the input voltage cycle. This presents a problem to the protection device, because it should always trip on an internal fault. The problem is that typical internal transformer faults may produce overcurrents which are not necessarily greater than the inrush current. Furthermore, faults tend to manifest themselves on switch on, due to the high inrush currents. For this reason, we need to find a mechanism that can distinguish between fault current and inrush current. Fortunately, this is possible due to the different natures of the respective currents. An inrush current waveform is rich in harmonics, especially 2nd harmonics, whereas an internal fault current consists only of the fundamental. We can therefore develop a restraining method based on the 2nd harmonic content of the inrush current. The mechanism by which this is achieved, is called second harmonic blocking.

2.8 Overfluxing restraint

Sometimes the protected transformer is subject to overfluxing due to temporary overloading with a voltage in excess of the nominal voltage, or a reduced voltage frequency. For example, when a load is suddenly disconnected from a power transformer, the voltage at the input terminals of the transformer may rise by 10-20% of the rated value. Since the voltage increases, the flux also increases. As a result, the transformer steady state excitation current becomes higher. The resulting excitation current flows in one winding only and therefore appears as differential current which may rise to a value high enough to operate the differential protection. A typical differential current waveform during such a condition is as follows.

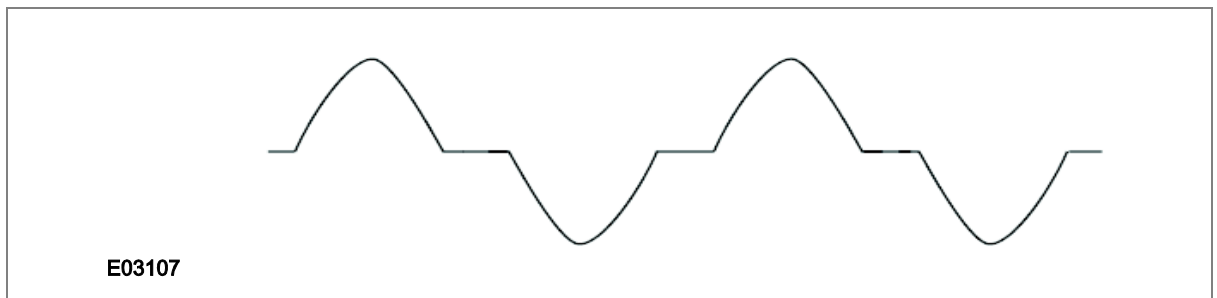

Figure 5: Typical overflux current waveform

Such waveforms have a significant 5th harmonic content. We can therefore develop a restraining method based on the 5th harmonic content of the inrush current. The mechanism by which this is achieved, is called fifth harmonic blocking.

2.9 Differential implementation

To enable or disable Differential Protection, set **DIFF PROTECTION** in the **CONFIGURATION** column.

2.9.1 Defining the transformer

To set up the transformer differential protection you need to define what type of transformer is being protected. You do this with settings in the **SYSTEM CONFIG** column.

The P652 only supports two-winding transformers.

The **Trafo Rating** setting sets the reference power of the protected transformer. This is used as a reference by the differential function to calculate the ratio correction factors. The Trafo rating refers to the maximum MVA rating specified in the transformer nameplate.

You can define each winding as Y (Star, or Wye), D (delta), or Z (zigzag) in the settings **HV connection** and **LV Connection**.

You also need to set the nominal voltage of each winding. You do this with the settings **HV Nominal and LV Nominal**.

The **HV Nominal Range** and **LV Nominal Range** settings are used to set the range of HV and LV nominal voltage to V (volts) / kV (Kilo Volts).

To ensure the device can perform vector group correction, you need to enter the vector group for the LV winding. To do this enter the relevant vector group reference (available on the nameplate) using the settings **LV Vector Group**.

2.9.2 Amplitude compensation

The P652 automatically calculates the matching factors for each of the CTs of protected windings on the basis of the calculated reference currents.

The reference currents **HV Iref** and **LV Iref** are calculated by using the setting parameters **Trafo Rating**, **HV Nominal** and **LV Nominal** from the **SYSTEM CONFIG** menu.

The reference current on HV side is calculated by using formula given below:

$$\text{HV Iref} = \text{Trafo rating} / (\sqrt{3} * \text{HV Nominal})$$

where

HV Iref = Calculated reference current for HV.

Trafo Rating = MVA rating of transformer.

HV Nominal = Nominal voltage of HV winding

Also the reference current on LV side “**LV Iref**” can be calculated in the same way.

The Matching factor on HV side is calculated by using formula given below:

$$\text{HV Match Factor} = \text{Inom} / \text{HV Iref}$$

Where

Inom = Nominal current of HV winding

The Matching factor on LV side is calculated by using formula given below:

$$\text{LV Match Factor} = \text{Inom} / \text{LV Iref}$$

If the matching factor is not in the range as specified below, the relay issues the warning and blocks the differential protection

$$0.5 < \text{Match Factor} < 12$$

The reference currents and match factors i.e. **HV Iref**, **LV Iref**, **HV Match Factor**” and **LV Match Factor** are automatically calculated by the relay and will be displayed in the **SYSTEM CONFIG** menu.

The measured values of the phase currents of the windings of the protected transformer are multiplied by the relevant matching factors and are then available for further processing (Phase compensation).

2.9.3 Phase compensation

Information about the transformers vector group is mentioned on the name plate of the transformer (provided by transformer manufacturer). The vector group identifies the connection of the windings and the phase relationship of the voltage phasor assigned to them.

The P652 relay requires setting for **LV Vector Group**, **LV Connection** and **HV Connection** parameter settings in **SYSTEM CONFIG** menu for automatically carrying out phase compensation.

For example if transformer connection setting is “**Yd11**”, then the HV winding is star connected and LV winding is Delta connected. The “11” numeral represents the phase shift code number. Every hour is multiplied by 30° to specify the angle by which the phasor of the low-voltage winding lags behind the phasor of the high-voltage winding.

There is no phase angle displacement between the primary and the secondary circuits with Zig-Zag connection; therefore, the Δ -zigzag connection can be used in the same manner as Y-Y and Δ - Δ transformers without introducing any phase shifts in the circuits.

Mathematical operations for Phase Compensation are automatically applied inside the relay.

2.9.4 Setting zero sequence filtering

To avoid the effect of the earth fault current on the operation of differential protection, the zero sequence current needs to be subtracted from the phase currents along with vector group matching.

In the event of system earth faults, the zero-sequence component of the fault current would flow via the earthed neutral that lies within the transformer differential protection zone and would thus appear in the measuring systems as differential current. The consequence would be undesirable tripping.

For this reason the zero-sequence component of the three-phase system must be eliminated from the phase currents on the high-voltage side or low voltage side.

On low voltage side with odd number of vector group, if the winding is grounded, then the zero sequence current is filtered automatically. In this case zero sequence current is not required to be subtracted from the phase currents. But the zero sequence current must be added to the phase current if winding is not grounded.

In the **SYSTEM CONFIG** menu the **HV Grounding** and **LV Grounding** setting defines whether the winding is earthed or not earthed. It is used to decide whether zero sequence filtering is required or not.

- **Grounded** = zero sequence filtering is implemented for that winding.
- **Ungrounded** = zero sequence filtering is not required.

The zero-sequence current is calculated by using the amplitude-matched phase currents.

$$I_0 = (\overline{I_A} + \overline{I_B} + \overline{I_C})/3$$

The measured values of the phase currents of the windings (with Amplitude and Phase corrected) of the protected transformer are available for further processing.

2.9.5 Transformer Differential operating characteristics

The P652 relay incorporated two slope tripping characteristics in order to issue the differential trip for the Transformer winding internal fault.

The differential tripping characteristic has two knees. The first knee is dependent on the settings of I_{s1} and $K1$. The second knee is defined by the setting I_{s2} and $K2$. The lower slope provides stability for low external faults. The higher slope provides stability for high through fault conditions, since transient differential currents may be present due to current transformer saturation.

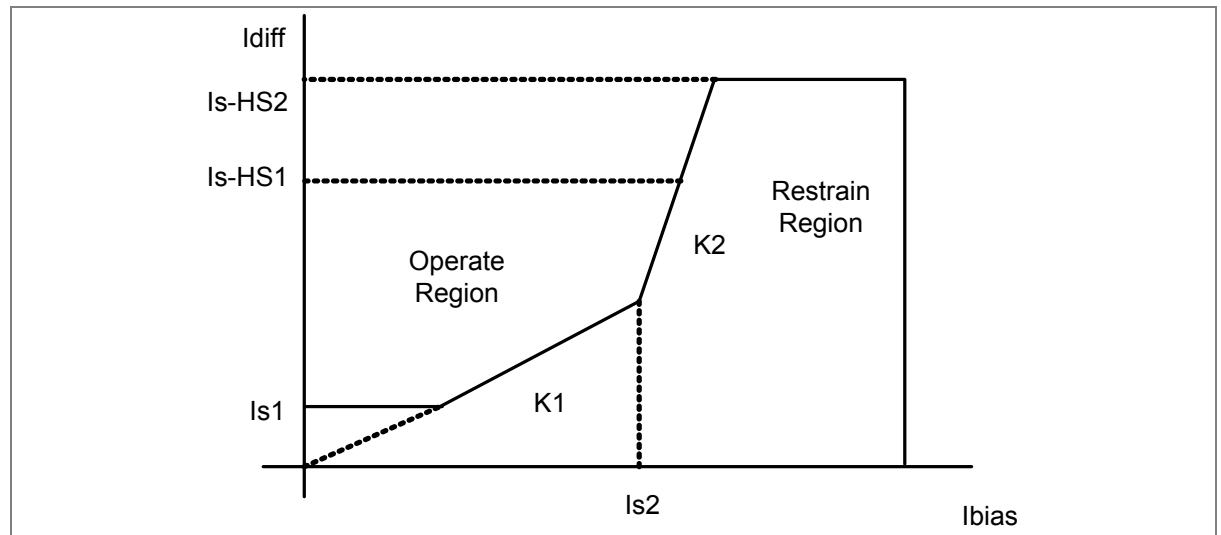

Figure 6: Transformer Differential operating characteristics

I_{diff} and I_{bias} are calculated by using formula given below:

The differential current is the vector sum of the HV and LV phase currents as follows:

$$I_{diff} = \left| \overline{\text{HV phase current}} + \overline{\text{LV phase current}} \right|$$

The bias current is defined as half of the scalar sum of the HV and LV phase current as follows:

$$I_{bias} = 0.5 \times \left\{ \left| \overline{\text{HV phase current}} \right| + \left| \overline{\text{LV phase current}} \right| \right\}$$

Once the differential and bias currents are calculated after amplitude and phase compensation, the following comparisons are made and an operate/restrain signal is obtained:

For the flat slope range: $0 \leq I_{bias_{max}} \leq I_{s1}/K1$

$$I_{diff} \geq I_{s1}$$

For the K1 slope range: $I_{s1}/K1 \leq I_{bias_{max}} \leq I_{s2}$

$$I_{diff} \geq K1 \cdot I_{bias_{max}}$$

For the K2 slope range: $I_{s2} \leq I_{bias_{max}} \leq I_{s-HS2}/K2$

$$I_{diff} \geq K1 \cdot I_{s2} + K2 (I_{bias_{max}} - I_{s2})$$

Where I_{diff} and I_{bias} are calculated current from HV and LV side current.

2.9.5.1 High set functions

There are two additional settings for the high internal fault in winding of the transformer (I_{s-HS1} and I_{s-HS2})

If the differential current is above the adjustable **Is-HS1** setting threshold, the device will trip if in the Operate region, but not in the restrain region. However, second harmonic blocking is not taken into account. The High Set 1 resets when the differential and bias currents are in the restraint area.

If the differential current is above the adjustable **Is-HS2** setting threshold, bias current is not taken into account and the device will trip regardless. As with High Set 1, second harmonic blocking is not taken into account. The High Set 2 element resets when the differential current drops below $0.95 \cdot I_{s-HS2}$.

2.9.5.2 5th harmonic blocking

Sometimes the protected transformer is subject to overfluxing due to temporary overloading with a voltage in excess of the nominal voltage. Hence steady state excitation current becomes higher. The resulting excitation current flows in one winding only and therefore appears as differential current which may rise to a value high enough to operate the differential protection. Such waveforms have a significant 5th harmonic content. We can therefore develop a restraining method based on the 5th harmonic content of the inrush current. The mechanism, by which this is achieved, is called 5th harmonic blocking.

The P652 relay filters the differential current to determine the fundamental $I_{diff}(fn)$ and fifth harmonic component $I_{diff}(5*fn)$. of the differential current are determined. The device uses these quantities to produce a blocking signal, which will block the protection in the event that the fifth harmonic component exceeds a certain level. If the ratio $I_{diff}(5*fn)/I_{diff}(fn)$ exceeds an adjustable threshold (**IH5 Diff Set**), Differential tripping is blocked.

The P652 relay provides 5th harmonic blocking function which can be used to prevent unwanted operation of the low set differential element under transient overfluxing conditions.

In the **DIFF PROTECTION** setting menu, 5th Harmonic blocking of a protection function can be enabled by setting **IH5 Diff Block** to 'Enabled'.

2.9.5.3 2nd harmonic blocking

The P652 relay filters the differential current to determine the fundamental $I_{diff}(fn)$ and second harmonic component $I_{diff}(2*fn)$. The device uses these quantities to produce a blocking signal, which will block the protection in the event that the second harmonic component exceeds a certain level. If the ratio $I_{diff}(2*fn)/I_{diff}(fn)$ exceeds an adjustable threshold (**IH2 Diff Set**) in at least one measuring system, Differential tripping is blocked.

The P652 relay provides 2nd harmonic blocking function to avoid the maloperation of the relay when transformer circuit experiences an inrush current.

In **DIFF PROTECTION** setting menu, 2nd harmonic blocking of a protection function can be enabled by setting **IH2 Diff Block** to 'Enabled'.

If the **Cross Blocking** setting in the **DIFF PROTECTION** menu is enabled, any one of the phase blocking signals will block all three phases.

No blocking signal is asserted if the differential current exceeds the set thresholds **Is-HS1** or **Is-HS2**.

2.10 Overcurrent protection principles (HV and LV)

Most power system faults result in an overcurrent of some kind. It is the job of protection devices, formerly known as relays but now known as Intelligent Electronic Devices (IEDs), to protect the power system from such faults. The general principle is to isolate the faults as quickly as possible to limit the danger and prevent unwanted fault currents flowing through systems, which can cause severe damage to equipment and systems. At the same time, we wish to switch off only the parts of the grid that are absolutely necessary, to prevent unnecessary blackouts. The protection devices that control the tripping of the grid's circuit breakers are highly sophisticated electronic units, providing an array of functionality to cover the different fault scenarios for a multitude of applications.

The described products offer a range of overcurrent protection functions including:

- Phase Overcurrent protection
- Earth Fault Overcurrent protection
- Negative Sequence Overcurrent protection
- Sensitive Earth Fault protection
- Restricted Earth Fault protection

To ensure that only the necessary circuit breakers are tripped and that these are tripped with the smallest possible delay, the IEDs in the protection scheme need to co-ordinate with each other. Various methods are available to achieve correct co-ordination between IEDs in a system.

These are:

- By means of time alone
- By means of current alone
- By means of a combination of both time and current.

Grading by means of current is only possible where there is an appreciable difference in fault level between the two locations where the devices are situated. Grading by time is used by some utilities but can often lead to excessive fault clearance times at or near source substations where the fault level is highest. For these reasons the most commonly applied characteristic in co-ordinating overcurrent devices is the IDMT (Inverse Definite Minimum Time) type.

The relay is designed for three stages programmable OC and EF functions for HV and LV windings. All three stages of overcurrent and earth fault protection function are programmable as Inverse Definite Minimum Time (IDMT) or Definite Time (DT) delay.

2.10.1 IDMT characteristics

All three stages of Overcurrent and Earth fault functions are programmable as per IDMT characteristic based on IEC and IEEE standards. The inverse time delay is calculated with the following mathematical formula:

$$t = T * \left(\frac{K}{\left(\frac{I}{I_s} \right)^\alpha - 1} + L \right)$$

where;

t: Operation time

K: Constant (see the table)

I: Measured current

I_s: Current threshold setting

α: Constant (see the table)

L: ANSI/IEEE constant (zero for IEC curve)

T: Time multiplier setting (TMS) for IEC curves or Time dial setting (TD) for IEEE curves

Description	Standard	K	α	L
Define Time	DT	-	-	0
Standard Inverse	IEC	0.14	0.02	0
Standard Inverse(1.3sec)	---	0.06	0.02	0
Very Inverse	IEC	13.5	1	0
Extremely inverse	IEC	80	2	0
Long Time Inverse	UK	120	1	0
Moderate Inverse	IEEE	0.0515	0.02	0.114
Very Inverse	IEEE	19.61	2	0.491
Extremely Inverse	IEEE	28.2	2	0.1217
US Inverse	CO8	5.95	2	0.18
US Short Time Inverse	CO2	0.02394	0.02	0.01694

2.10.2 Principle of protection function implementation

An energising quantity is a current input from a system current transformer or another quantity derived from the current input. The energising quantities are extracted from the power system and presented to the IED in the form of analogue signals. These analogue signals are then converted to digital quantities where they can be processed by the IEDs internal processor.

In general, an energising quantity is compared with a threshold value, which may be settable or hard-coded depending on the function. If the quantity exceeds (for overvalues) or falls short of (for undervalues) the threshold, a signal is produced, which when gated with the various inhibit and blocking functions becomes the Start signal for that protection function. This Start signal is generally made available to Fixed Scheme logic for further processing. It is also passed through a timer function to produce the Trip signal. The timer function may be an IDMT curve, or a Definite Time delay, depending on the function. The timer can be configured by a range of settings to define such parameters as the type of curve, The Time Multiplier Setting, the IDMT constants and Definite Time delay.

In the P652 there are several independent stages for each of the functions. All the stages (1, 2 and 3) can be set for DT/IDMT timer function. If the DT time delay is set to '0', then the function is known to be "instantaneous". In many instances the term "instantaneous protection" is used loosely to describe Definite Time protection stages even when the stage may not theoretically be instantaneous.

2.10.3 Timer hold facility/reset characteristics

This feature may be useful in certain applications, such as when grading with upstream electromechanical overcurrent relays, which have inherent reset time delays. If you set the hold timer to a value other than zero, the resetting of the protection element timers will be delayed for this period. This allows the element to behave in a similar way to an electromechanical relay. If you set the hold timer to zero, the overcurrent timer for that stage will reset instantaneously as soon as the current falls below a specified percentage of the current setting (typically 95%).

Another possible situation where the timer hold facility may be used to reduce fault clearance times is for intermittent faults. An example of this may occur in a plastic insulated cable. In this application it is possible for the fault energy to melt and reseal the cable insulation, thereby extinguishing the fault. This process repeats to give a succession of fault current pulses, each of increasing duration with reducing intervals between the pulses, until the fault becomes permanent.

When the reset time is instantaneous, the device will repeatedly reset and not be able to trip until the fault becomes permanent. By using the Timer Hold facility the device will integrate the fault current pulses, thereby reducing fault clearance time.

The timer hold facility is available to all three stages of OC and EF functions.

The Definite Time Reset characteristic is applicable for IEC curves/DT.

The value of the Reset Timer depends on the type of the timer associated to the pick-up phase (Earth) threshold.

Type of timer associated with phase (earth) threshold	Reset Timer	
	DT Reset Characteristic	IDMT Reset Characteristic
- For DT time delay	0 – 100 sec	Not available
- For IDMT IEC time delay	0 – 100 sec	Not available
- For IDMT IEEE or CO time delay	0 – 100 sec	Based on RTMS value (0.025-1.2)

The mathematical formula applicable to the five curves is:

$$t = \frac{RTMS \times K}{1 - (I / I_s)^\alpha}$$

Where:

- t = Reset time
- K = Factor (see table)
- I = Value of the measured current
- I_s = Value of the programmed threshold (pick-up value)
- α = Factor (see table)
- RTMS Reset time multiplier (RTMS) setting is between 0.025 and 1.2

Description	Standard	K	α
Moderate Inverse	IEEE	4.85	2
Very Inverse	IEEE	21.6	2
Extremely Inverse	IEEE	29.1	2
US Inverse	CO8	5.95	2
US Short Time Inverse	CO2	2.261	2

2.11 Phase overcurrent protection

Phase current faults are faults where fault current flows between two or more phases of a three-phase power system. The fault current may be between the phase conductors only or, between two or more phase conductors and earth. There are three types of phase fault:

- Line to Line (accounting for approximately 8% of all faults)
- Line to Line to Earth (accounting for approximately 5% of all faults)
- Line to Line to Line (accounting for approximately 2% of all faults)

Although not as common as earth faults (single line to earth), phase faults are typically more severe.

An example of a phase fault is where a fallen tree branch bridges two or more phases of an overhead line.

2.11.1 Phase Overcurrent Protection implementation

Phase Overcurrent Protection is implemented in the **OVERCURRENT** column of the relevant settings group. The relay provides phase overcurrent protection for HV & LV winding and relevant settings can be done under **HV OVERCURRENT** and **LV OVERCURRENT** submenu.

The product provides three stages of three-phase overcurrent protection with independent time delay characteristics for HV and LV windings. All settings apply to all three phases but are independent for each of the three stages.

Stages 1, 2 and 3 provide a choice of operate and reset characteristics, where you can select between:

- A range of standard IDMT (Inverse Definite Minimum Time) curves
- DT (Definite Time)

This is achieved using the cells

- **I>(n) Function** for the overcurrent operate characteristic
- **I>(n) Reset Char** for the overcurrent reset characteristic

where (n) is the number of the stage.

The IDMT capable stages, (1, 2 and 3) also provide a Timer Hold facility. This is configured using the cells **I>(n) tRESET**, where (n) is the number of the stage. Timer Hold facility is applicable for both IEC and IEEE curves. IEEE & US curves have IDMT reset curve option in addition to DT Phase Overcurrent protection logic.

Phase Overcurrent modules are level detectors that detect when the current magnitude exceeds a set threshold. When this happens, the Phase Overcurrent module in question issues a signal to produce the **Start** signal. This **Start** signal is applied to the IDMT/DT timer module. It is also made available directly to the user for use in the logic functions.

There are three Phase Overcurrent Modules, one for each phase. The three **Start** signals from each of these phases and common **Start** signal for each stage of phase overcurrent function is available for customer use.

The outputs of the IDMT/DT timer modules are the trip signals which are used to drive the tripping output relay. The three **Trip** signals from each of the phases and common **Trip** signal for each stage of phase overcurrent function is available for customer use.

The Phase overcurrent trip signal can be blocked by:

- The Second Harmonic blocking function which is for all three phases. The blocking is activated by setting the **I> (n) 2H Blocking** cell to 'Enabled', where (n) is the number of the stage.
- User defined blocking logic using 'IO Mask' functionality.

2.12 Negative sequence overcurrent protection (HV and LV)

When applying standard phase overcurrent protection, the overcurrent elements must be set significantly higher than the maximum load current, thereby limiting the element's sensitivity. Most protection schemes also use an earth fault element operating from residual current, which improves sensitivity for earth faults.

However, certain faults may arise which can remain undetected by such schemes. Negative Sequence Overcurrent elements can be used in such cases.

Any unbalanced fault condition will produce a negative sequence current component. Therefore, a negative phase sequence overcurrent element can be used for both phase-to-phase and phase-to-earth faults.

Negative Sequence Overcurrent protection offers the following advantages:

- Negative phase sequence overcurrent elements are more sensitive to resistive phase-to-phase faults, where phase overcurrent elements may not operate.
- In certain applications, residual current may not be detected by an earth fault element due to the system configuration. For example, an earth fault element applied on the delta side of a delta-star transformer is unable to detect earth faults on the star side. However, negative sequence current will be present on both sides of the transformer for any fault condition, irrespective of the transformer configuration. Therefore, a negative phase sequence overcurrent element may be used to provide time-delayed back-up protection for any uncleared asymmetrical faults downstream.
- Where rotating machines are protected by fuses, loss of a fuse produces a large amount of negative sequence current. This is a dangerous condition for the machine due to the heating effect of negative phase sequence current. An upstream negative phase sequence overcurrent element could therefore be applied to provide back-up protection for dedicated motor protection relays.
- It may be sufficient to simply trigger an alarm to indicate the presence of negative phase sequence currents on the system. Operators may then investigate the cause of the imbalance.

2.12.1 Negative sequence overcurrent protection implementation

Negative sequence overcurrent protection is implemented in the **NEG SEQUENCE O/C** column of the relevant settings group. The relay provides negative sequence overcurrent protection for HV & LV winding and relevant settings can be done under **HV NEG SEQ O/C** and **LV NEG SEQ O/C** submenu.

The product provides three stages of negative sequence overcurrent protection with independent time delay characteristics for HV and LV winding.

Stages 1, 2 and 3 provide a choice of operate and reset characteristics, where you can select between:

- A range of standard IDMT (Inverse Definite Minimum Time) curves
- DT (Definite Time)

This is achieved using the cells

- **I2>(n) Function** for the overcurrent operate characteristic
- **I2>(n) Reset Char** for the overcurrent reset characteristic

where (n) is the number of the stage.

The IDMT-capable stages, (1, 2 and 3) also provide a Timer Hold facility. This is configured using the cells **I2>(n) tRESET**, where (n) is the number of the stage. Timer Hold facility is applicable for both IEC and IEEE curves. IEEE & US curves have IDMT reset curve option in addition to DT.

2.12.2 Negative sequence overcurrent protection logic

For negative phase sequence overcurrent protection, the energising quantity $I_{2>}$ is compared with the threshold current **$I_{2>}(n)$ Current Set**. If the value exceeds this setting, a start signal is generated, provided there are no blocks. 5% hysteresis is built into the comparator such that the drop-off value is 0.95 x of the current set threshold.

The $I_{2>}$ start signal is fed into a timer to produce the $I_{2>}$ trip signal.

The Negative Sequence overcurrent trip signal can be blocked by:

- The Second Harmonic blocking function which is for all three phases. The blocking is activated by setting the **$I_{2>}(n)$ 2H Blocking** cell to 'Enable', where (n) is the number of the stage.
- User defined blocking logic using 'IO Mask' functionality

2.13 Earth fault protection (HV and LV)

Earth faults are simply overcurrent faults where the fault current flows to earth (as opposed to between phases). They are the most common type of fault. There are a few different kinds of earth fault, but the most common is the single phase-to-earth fault. Consequently this is the first and foremost type of fault that protection devices must cover.

Typical settings for earth fault IEDs are around 30-40% of the full load current. If greater sensitivity is required, then Sensitive Earth Fault should be used.

Earth faults can be measured directly from the system by means of:

- A separate CT located in a power system earth connection
- A separate Core Balance CT (CBCT)
- A residual connection of the three line CTs, whereby the Earth faults can be derived mathematically by summing the three measured phase currents.

Depending on the device model, it will provide one or more of the above means for Earth fault protection.

2.13.1 Earth fault protection elements

Earth fault protection is implemented in the column **EARTH FAULT** of the relevant settings group.

The relay provides Earth Fault protection for HV & LV winding and relevant settings can be done under **HV EARTH FAULT** and **LV EARTH FAULT** submenu.

Based on the Earth Fault setting as Measured/Derived, EARTH FAULT (IN) column will be used for earth fault current that is measured directly from the system or operate from a residual current quantity that is derived internally from the summation of the three-phase currents.

Note: Measured Earth Fault option should not be used if REF protection for this winding is enabled and selected for HighZ REF.

The product provides three stages of Earth Fault protection with independent time delay characteristics, for each winding (HV and LV).

Stages 1, 2 and 3 provide a choice of operate and reset characteristics, where you can select between:

- A range of standard IDMT (Inverse Definite Minimum Time) curves
- DT (Definite Time)

This is achieved using the cells

- **IN>(n) Function** for the overcurrent operate characteristics

- **IN>(n) Reset Char** for the overcurrent reset characteristic

where (n) is the number of the stage.

Stages 1, 2 and 3 provide a Timer Hold facility. This is configured using the cells **IN>(n) tRESET** for Earth Fault.

2.13.2 Earth Fault protection logic

The Earth Fault current is compared with a set threshold (IN>(n) Current) for each stage. If it exceeds this threshold, a Start signal is triggered, provided there are no blocks.

Earth Fault protection can follow the same IDMT characteristics as described in the Overcurrent Protection Principles section. Please refer to this section for details of IDMT characteristics.

The Earth Fault protection trip signal can be blocked by:

- The Second Harmonic blocking function is for all three phases. The blocking of Earth Fault is activated by setting the **IN> (n) 2H Blocking** cell to 'Enabled', where (n) is the number of the stage.
- User defined blocking logic using 'IO Mask' functionality

2.14 Restricted Earth Fault protection (HV and LV)

Winding-to-core faults in a transformer are quite common due to insulation breakdown. Such faults can have very low fault currents, but they are faults nevertheless and have to be picked up, as they can still severely damage expensive equipment. Often the fault currents are even lower than the nominal load current. Clearly, neither overcurrent nor percentage differential protection is sufficiently sensitive in this case. We therefore require a different type of protection arrangement. Not only should the protection arrangement be sensitive, but it must create a protection zone, which is limited to the transformer windings. Restricted Earth Fault (REF) protection satisfies these conditions.

The figure below shows an REF protection arrangement for the delta side of a delta-star transformer. The current transformers measuring the currents in each phase are connected in parallel. A fault outside the protection zone (i.e. outside the delta winding) will not result in a spill current, as the fault current would simply circulate in the delta windings. However, if any of the three delta windings were to develop a fault, the impedance of the faulty winding would change and that would result in a mismatch between the phase currents, resulting in a spill current, sufficient to trigger a trip command.

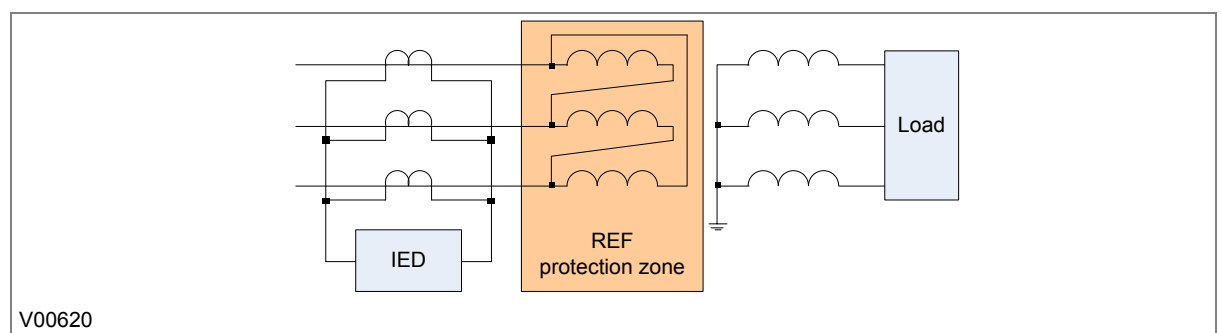

Figure 7: REF protection for delta side

The figure below shows an REF protection arrangement for the star side of a delta-star transformer. Here we have a similar arrangement of current transformers connected in parallel. The only difference is that we need to measure the zero sequence current in the neutral line as well. We know that an external unbalanced fault causes zero sequence current to flow through the neutral line, resulting in uneven currents in the phases, which would cause the IED to malfunction. By measuring this zero sequence current and placing the current transformer in parallel with the other three, the currents are balanced up resulting in stable operation.

Now only a fault inside the star winding can create an imbalance sufficient to cause the IED to issue a trip command.

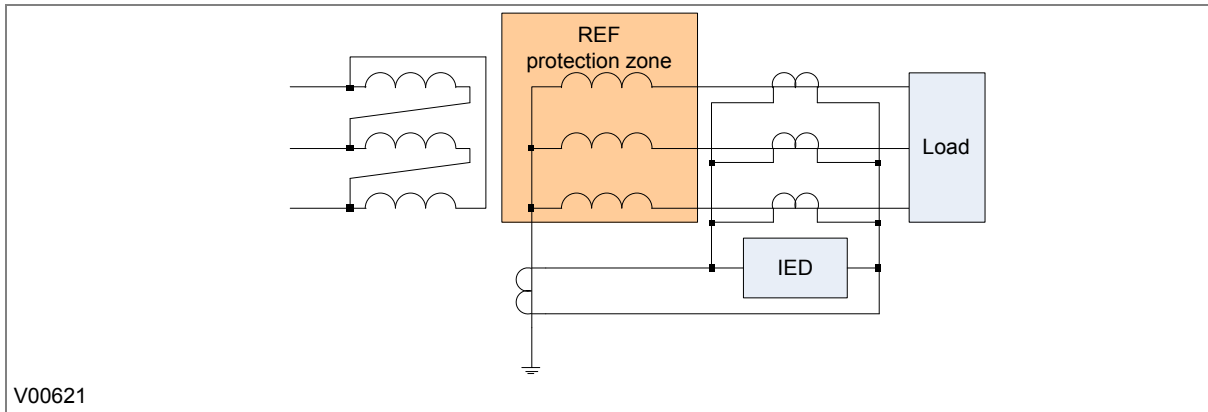

Figure 8: REF protection for star side

The relay supports High/ Low Impedance technique for REF. The high impedance technique ensures that the circuit is of sufficiently high impedance such that the differential voltage that may occur under external fault conditions is less than that required to drive setting current through the device.

2.14.1 Restricted Earth Fault implementation

REF element is available for each of the windings (HV and LV side). For each of these windings, you can disable REF protection or set it to Low Impedance or High Impedance using the settings **REF HV Status**, **REF LV Status** in the **REF PROTECTION** column.

2.14.2 Application Note

2.14.2.1 Low impedance REF

Low impedance REF uses a bias characteristic for increasing sensitivity and stabilising for through faults. The current required to trip the differential element is called the Operate current. This Operate current is a function of the differential current and the bias current according to the bias characteristic and those formula is given below:-

The differential current is defined as follows:

$$I_{diff} = K(\bar{I}_A + \bar{I}_B + \bar{I}_C) + \bar{I}_N$$

The bias current is as follows

$$I_{Bias} = \frac{1}{2}\{K(\max[|I_A| + |I_B| + |I_C|]) + |I_N|\}$$

Where:

- Scaling Factor K = Line CT ratio / Neutral CT ratio (0.5 < K < 12).
- I_N = current measured by the neutral CT.

The following settings are provided to define this bias characteristic:

- **Is1 Set:** sets the minimum trip threshold
- **Is2 Set:** sets the bias current knee point whereby the required trip current starts increasing.

- **IREF K1:** defines the first slope.
- **IREF K2:** defines the second slope.

Bias characteristics for Low Impedance:

The flat slope of the characteristic is the minimum differential current required to cause a trip at low bias currents. From the first knee point onwards, the operate current increases linearly with bias current, as shown by the lower slope on the characteristic. This lower slope provides sensitivity for internal faults. From the second knee point onwards, the operate current further increases linearly with bias current, but at a higher rate. The second slope provides stability under through fault conditions. Bias Characteristics for Low Impedance is shown in the following figure.

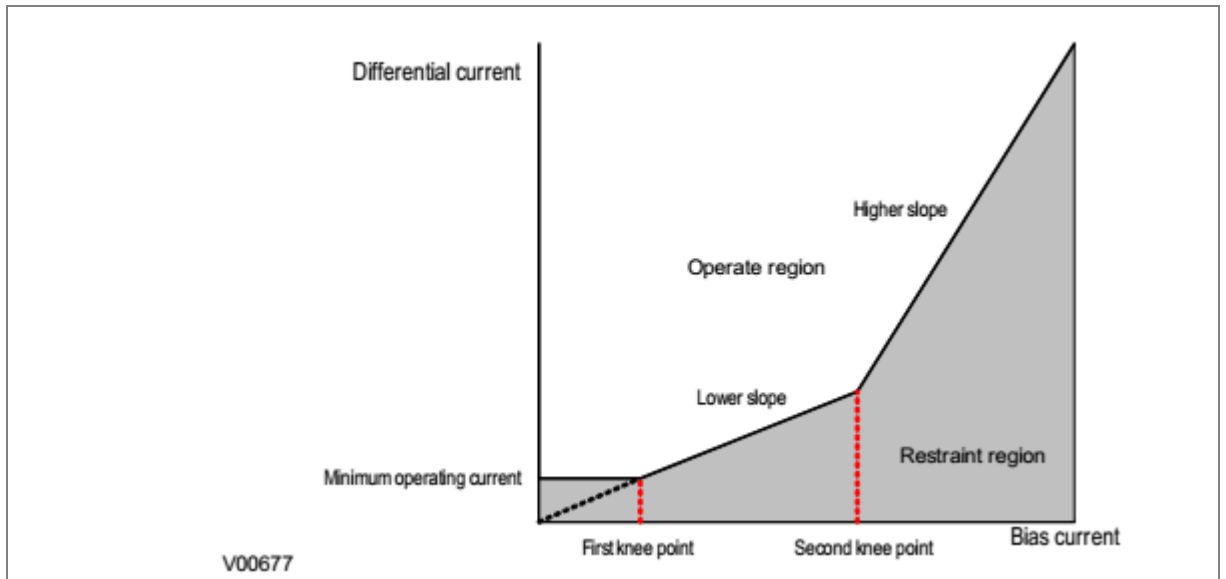

Figure 9: Percentage biased Differential Characteristics for LoZ REF function

The electrical connection diagram for the low impedance is shown below. The current from the Low impedance REF CT can also be used for standby earth fault function.

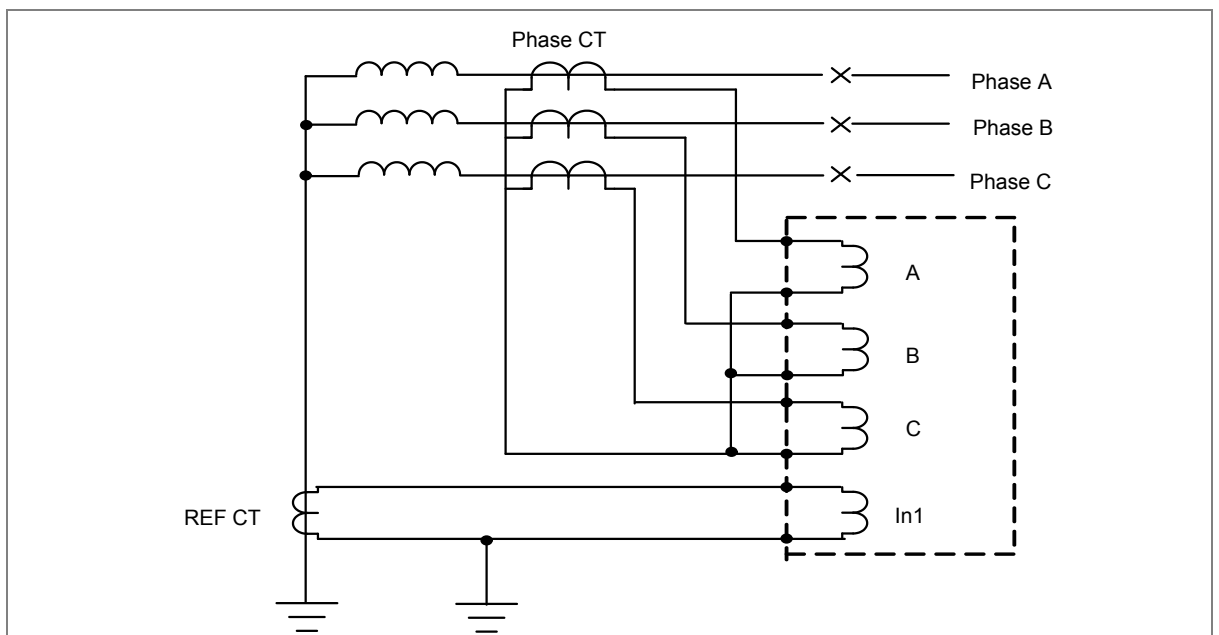

Figure 10: CT connection diagram for low impedance REF application

2.14.2.2 High impedance REF

The restricted earth fault relay is high impedance differential scheme which balance the zero sequence current flowing in the transformer neutral against zero sequence current flowing in transformer phase windings. Any unbalance in-zone fault will result in an increasing voltage on the CT secondary and thus will activate the REF protection.

The high impedance differential technique ensures that the impedance of the circuit is of sufficiently high so that the differential voltage that may occur under external fault conditions is lower than the voltage required driving setting current through the relay. This ensures stability against external fault conditions and then the relay will operate only for faults occurring inside the protected zone.

2.14.2.2.1 High impedance principle

High impedance schemes are used in a differential configuration, where one current transformer is completely saturated and the other CTs are healthy.

In the P652 relay IN1 CT is associated with the HV winding high impedance REF and IN2 CT is associated with the LV winding high impedance REF.

The following setting is done for High impedance REF protection.

- IREF Is setting.

The high impedance principle is best explained by considering a differential scheme where one CT is saturated for an external fault, as shown below.

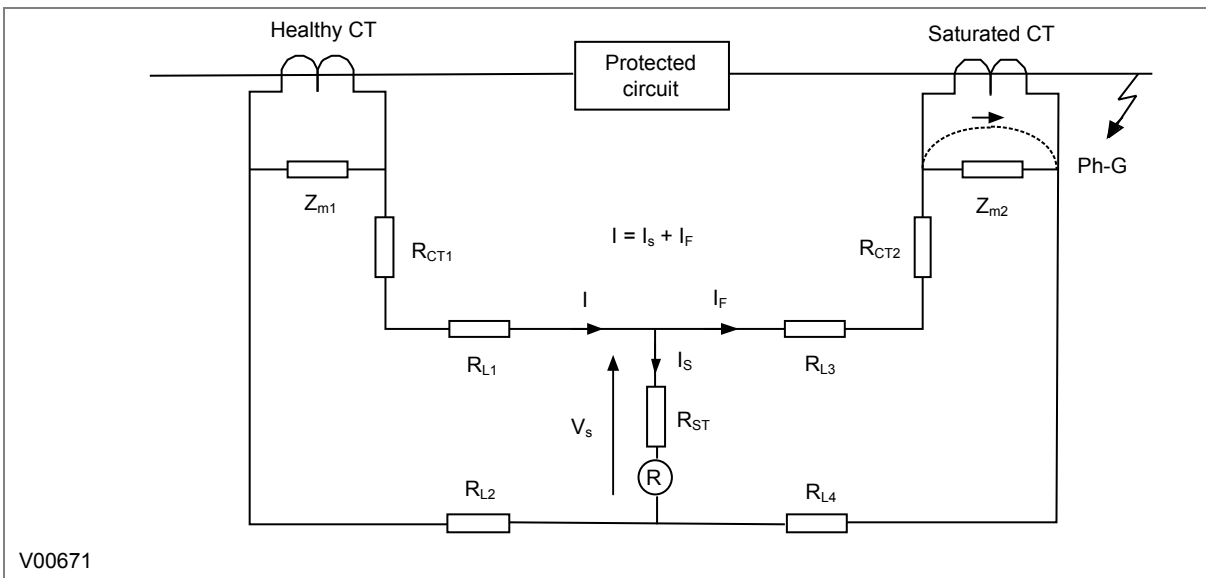

Figure 11: High Impedance principle

If the IED circuit has a very high impedance, the secondary current produced by the healthy CT will flow through the saturated CT. If CT magnetising impedance of the saturated CT is considered to be negligible, the maximum voltage across the circuit will be equal to the secondary fault current multiplied by the connected impedance, $(R_{L3} + R_{L4} + R_{CT2})$.

The IED can be made stable for this maximum applied voltage by increasing the overall impedance of the circuit, such that the resulting current through it is less than its current setting. As the impedance of the IED input alone is relatively low, a series connected external resistor is required. The value of this resistor, R_{ST} , is calculated by the formula shown. An additional non-linear, Metrosil, may be required to limit the peak secondary circuit voltage during internal fault conditions.

Voltage across REF element $V_s = I_F (R_{CT2} + R_{L3} + R_{L4})$

Stabilising resistor $R_{ST} = V_s / I_s - R_R$

where:

- I_F = maximum secondary through fault current
- R_R = device burden
- R_{CT} = CT secondary winding resistance
- R_{L2} and R_{L3} = Resistances of leads from the device to the current transformer
- R_{ST} = Stabilising resistor

To ensure that the protection will operate quickly during an internal fault, the CTs used to operate the protection must have a knee-point voltage significantly higher than voltage V_s .

The necessary connections for high impedance REF are as follows:

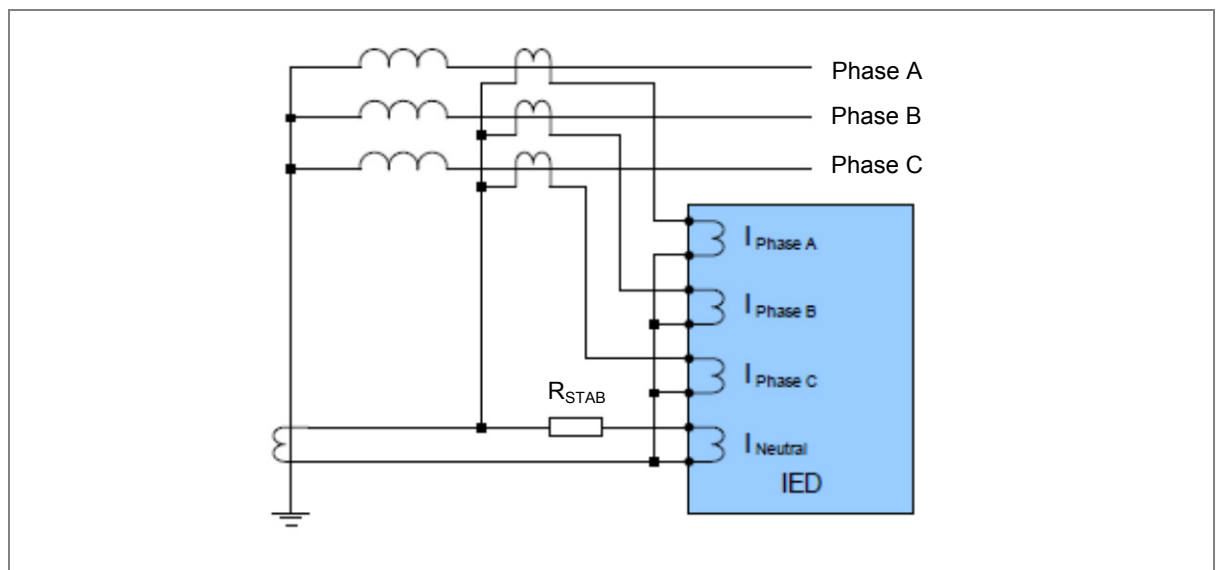

Figure 12: High Impedance REF connection

2.15 Thermal Overload function

The heat generated within an item of plant, such as a cable or a transformer, is the resistive loss (I^2Rt). The thermal time characteristic is therefore based on the square of the current integrated over time. The device automatically uses the largest phase current for input to the thermal model.

The equipment is designed to operate continuously at a temperature corresponding to its full load rating, where the heat generated is balanced with heat dissipated. Over-temperature conditions occur when currents in excess of their maximum rating are allowed to flow for a period of time. It is known that temperature changes during heating follow exponential time constants.

The device provides single time constant characteristic which is used to protect cables, dry type transformers (e.g. type AN), and capacitor banks.

Thermal overload protection is designed to prevent the electrical equipment when operating temperature is exceeded the maximum designed temperature. The RMS currents are measured and analysed to monitor the thermal state. In case of thermal overload function the calculation of the Time to Trip is given by:

$$t = \tau \ln \left(\frac{(K^2 - A)}{(K^2 - 1)} \right)$$

Where:

t: Time to trip (in seconds)

τ : Thermal time constant (T_e , in seconds) of the equipment to be protected

K : Thermal overload equal to $(I_{rms} / k \cdot \text{Thermal Trip})$

Where:

I_{rms} : RMS current corresponding to the largest phase current of HV or LV winding depending on the **Thermal Overload** menu setting as **HV** or **LV**.

Thermal Trip: Full load current rating (settable) based on the Thermal overload selection for **HV** or **LV** winding.

k : Settable (1 to 1.5 step 0.01)

A : Initial thermal state. If the initial thermal state is 50% then $A = 0.5$

The calculation of the thermal state is given by the following formula:

$$\Theta_{i+1} = (I_{rms} / k \cdot \text{Thermal Trip})^2 \cdot [1 - \exp(-t/T_e)] + \Theta_i \cdot \exp(-t/T_e)$$

Thermal Alarm Function (Thermal Alarm):

The purpose of this function is to produce an alarm signal indicating that the thermal state θ of the Transformer has exceeded "Alarm Threshold" setting 20% to 100%. Corrective action can thus be taken before thermal tripping occurs.

The equation used to calculate the time to the thermal alarm is:

$$\text{Thermal alarm} = \tau \cdot \ln(k^2 / (k^2 - \text{Th Alarm} / 100))$$

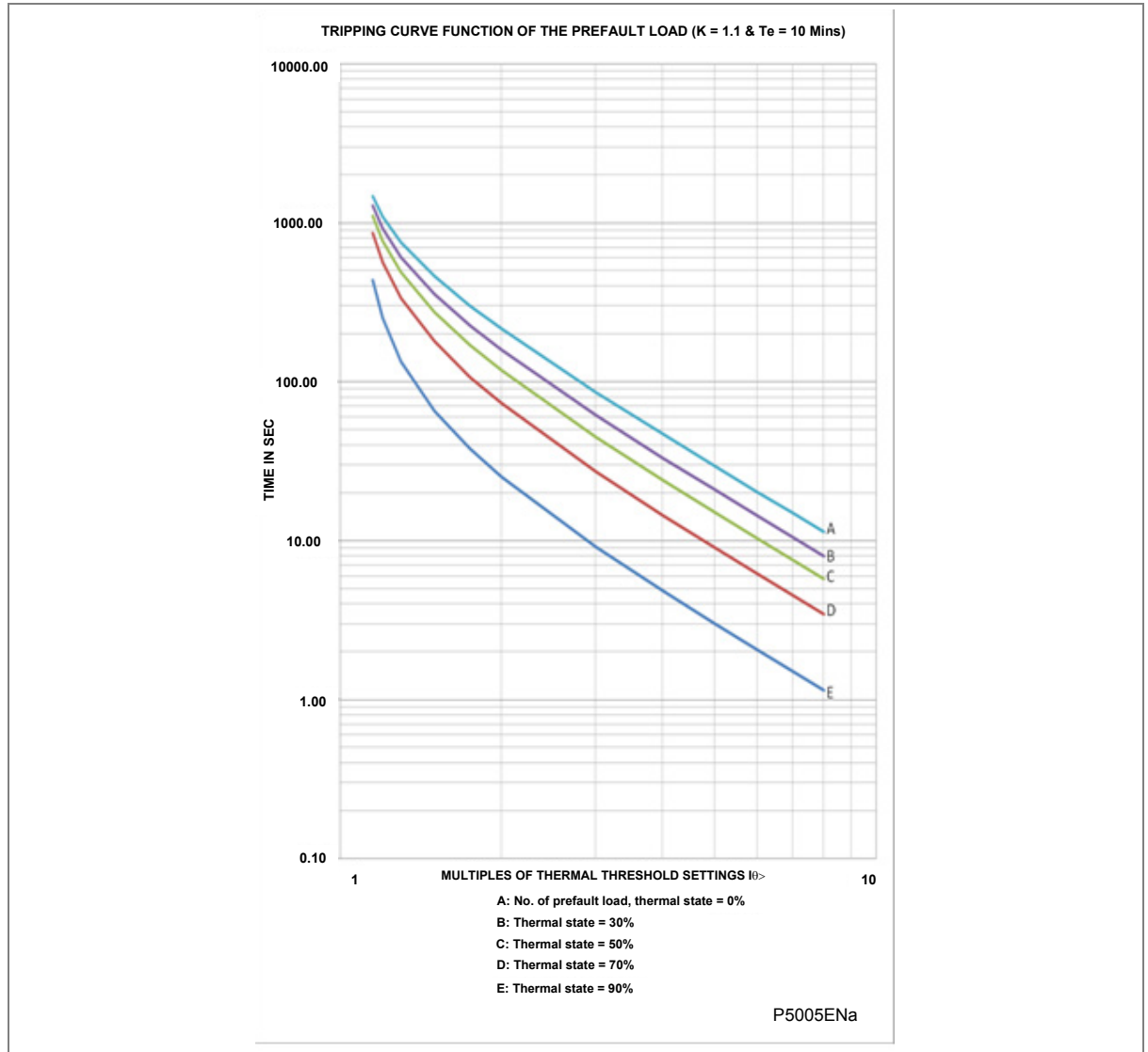

Figure 13: Thermal Overload curve

2.15.1 Thermal Overload protection implementation

The device incorporates a current-based thermal characteristic, using fundamental load current to model heating and cooling of the protected plant. The element can be set with both alarm and trip stages.

Thermal Overload protection is implemented in the **THERMAL OVERLOAD** column of the relevant settings group. The P652 relay incorporates the option of selecting this function for HV or LV side.

The magnitudes of the three phase input currents are compared and the largest magnitude is taken as the input to the thermal overload function.

Thermal over load function supports setting for alarm and trip stages. If the thermal overload function is enabled and thermal state of the protected equipment exceeds the alarm threshold setting, the alarm is issued and indicated by illuminated **START** LED on the relay front panel.

If the thermal overload function is enabled and thermal state of the protected equipment exceeds the Trip threshold setting, a trip command is issued resulting in operation of output contacts. Trip condition is indicated by illuminated **TRIP** LED.

The thermal state measurement is made available in the **MEASUREMENTS** menu.

The thermal state can be reset from the HMI panel by enabling the **Thermal Reset** setting to 'Yes' under **RECORD CONTROL** menu.

2.16 Circuit Breaker Fail protection (HV and LV)

When a fault occurs, one or more protection devices will operate and issue a trip command to the relevant circuit breakers. Operation of the circuit breaker is essential to isolate the fault and prevent, or at least limit, damage to the power system. For transmission and sub-transmission systems, slow fault clearance can also threaten system stability.

For these reasons, it is common practise to install Circuit Breaker Failure protection (CBF). CBF protection monitors the circuit breaker and establishes whether it has opened within a reasonable time. If the fault current has not been interrupted following a set time delay from circuit breaker trip initiation, the CBF protection will operate, whereby the upstream circuit breakers are back-tripped to ensure that the fault is isolated.

CBF operation can also reset all start output contacts, ensuring that any blocks asserted on upstream protection are removed.

2.16.1 Circuit Breaker Fail implementation

Circuit Breaker Failure Protection is implemented in the **CB FAIL** column of the relevant settings group. The CB Fail function is available for HV and LV breaker.

The circuit breaker failure protection incorporates **CB Fail Timer**. For any protection trip, the **CB Fail Timer** is started, and normally reset when the circuit breaker opens to isolate the fault. If breaker opening is not detected, the CB Fail Timer times out and close an output contact assigned to breaker fail (using the I/O assignment feature). This contact is used to back-trip upstream switchgear, generally tripping all infeeds connected to the same busbar section.

2.16.2 Circuit Breaker Fail logic (HV and LV)

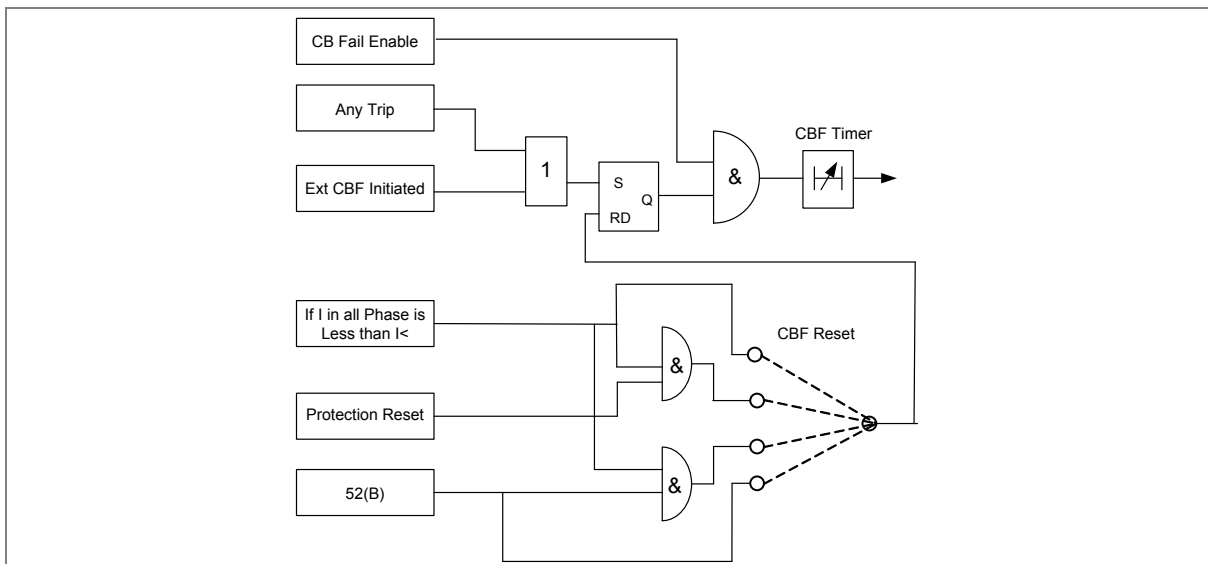

Figure 14: CB Fail logic

CBF elements CB Fail Timer can be configured to operate for trips triggered by protection elements within the device or via an external protection trip. The latter is achieved by allocating one of the opto-isolated inputs to CBF Init signal using the I/O Mask feature.

It is possible to reset the CBF from a breaker open indication from a protection reset. In these cases resetting is only allowed provided the undercurrent elements have also been reset. The resetting options are summarised in the following table:

CBF function Reset options	Description
I<	CBF function will reset when the phase current is less than set current
CB Open + I<	CBF function will reset when both conditions are satisfied: <ul style="list-style-type: none"> • CB is open (i.e. CB(52B) status is active) • The phase current is less than set current
Prot Reset + I<	CBF function will reset when both conditions are satisfied: <ul style="list-style-type: none"> • Protection is reset • Phase current is less than set current
CB Open	CBF function will reset when CB is open (i.e. CB(52B) status is active)

The **Remove I> Start** setting is used to remove starts issued from the overcurrent and earth elements respectively following a breaker fail time out. The start is removed when the cell is set to 'Enabled'.

2.17 Inrush current blocking function (2ND Harm Blocking)

When a transformer is initially connected to a source of AC voltage, there may be a substantial surge of current through the primary winding called inrush current. This is analogous to the inrush current exhibited by an electric motor that is started up by sudden connection to a power source, although transformer inrush is caused by a different phenomenon.

In an ideal transformer, the magnetizing current would rise to approximately twice its normal peak value as well, generating the necessary MMF to create this higher-than-normal flux. However, most transformers are not designed with enough of a margin between normal flux peaks and the saturation limits to avoid saturating in a condition like this, and so the core will almost certainly saturate during this first half-cycle of voltage. During saturation, disproportionate amounts of MMF are needed to generate magnetic flux. This means that winding current, which creates the MMF to cause flux in the core, could rise to a value way in excess of its steady state peak value. Furthermore, if the transformer happens to have some residual magnetism in its core at the moment of connection to the source, the problem could be further exacerbated.

We can see that inrush current is a regularly occurring phenomenon and should not be considered a fault, as we do not wish the protection device to issue a trip command whenever a transformer or machine is switched on. This presents a problem to the protection device, because it should always trip on an internal fault. The problem is that typical internal transformer faults may produce overcurrents which are not necessarily greater than the inrush current. Furthermore faults tend to manifest themselves on switch on, due to the high inrush currents. For this reason, we need to find a mechanism that can distinguish between fault current and inrush current. Fortunately this is possible due to the different natures of the respective currents. An inrush current waveform is rich in harmonics, whereas an internal fault current consists only of the fundamental. We can thus develop a restraining method based on the harmonic content of the inrush current. The mechanism by which this is achieved is called second harmonic blocking.

2.17.1 Second harmonic blocking implementation (HV and LV)

Second harmonic blocking can be applied to the following overcurrent protection types:

- Phase Overcurrent protection
- Earth Fault protection
- Negative sequence overcurrent protection

Second harmonic blocking is implemented in the **GROUP (n) SYSTEM CONFIG** column, where (n) is the number of the setting group.

Second harmonic blocking is applicable to all stages of each of the elements.

The function works by identifying and measuring the inrush currents present at switch on. It does this by comparing the value of the second harmonic current components to the value of the fundamental component. If this ratio exceeds the set thresholds, then the blocking signal is generated. The threshold is defined by the **IH2 HV Set & IH2 LV Set** setting for HV and LV winding respectively.

We only want the function to block the protection if the fundamental current component is within the normal range. If this exceeds the normal range, then this is indicative of a fault, which must be protected. For this reason there is another settable trigger **I> lift 2H HV**, which when exceeded, stops the 2nd harmonic blocking function.

Each overcurrent protection element has a **2H Blocking** setting with which the type of blocking is defined.

2.18 Through fault function

Through-fault monitoring can be enabled in the **THROUGH FAULT** column. The through-fault current monitoring function monitors the through fault current level.

A single-stage alarm is available for through-fault monitoring. The alarm is issued if the monitored current exceeds the through fault current threshold setting **TF I> Trigger**.

The Through fault condition can be monitored by setting **Monitoring input** to HV/LV/Bias current as per the customer's application requirement.

CURRENT TRANSFORMER REQUIREMENTS

CHAPTER 7

1 CHAPTER OVERVIEW

This chapter consists of the following sections:

- 1 Chapter Overview**
- 2 Current Transformer Requirements**
 - 2.1 Current Transformer Theory
 - 2.2 CT Requirements - Transformer Differential Protection Application
 - 2.3 CT Requirements - Low Impedance REF Protection Application
 - 2.4 CT Requirements - High Impedance REF Protection Application

2 CURRENT TRANSFORMER REQUIREMENTS

2.1 Current Transformer Theory

The current flowing in the primary winding produces an alternating flux in the core and this flux induces an e.m.f. in the secondary winding. This results in the flow of secondary current when this winding is connected to an external closed circuit. The magnetic effect of the secondary current is in opposition to that of the primary. The value of the secondary current automatically adjusts itself to such a value that the resultant magnetic effect of the primary and secondary currents, produces a flux required to induce the e.m.f. necessary to drive the secondary current through the impedance of the secondary. In an ideal transformer, the primary ampere-turns are always exactly equal to the secondary ampere-turns and the secondary current is, therefore, always proportional to the primary current. In an actual current transformer, however, this is never the case. All core materials require a certain number of ampere-turns to induce the magnetic flux required to induce the necessary voltage. The most accurate current transformer is where the exciting ampere-turns are least in proportion to the secondary ampere-turns.

In many applications core saturation will almost inevitably occur during the transient phase of a heavy short circuit. The performance of the current transformers during faults is, therefore, an important consideration in providing an effective relaying scheme. In any current transformer the first consideration is the highest secondary winding voltage possible prior to core saturation.

This may be calculated from: $E_k = 4.44 \times B \times A \times f \times N$ volts

Where:

E_k = secondary induced volts (rms value, known as the knee-point voltage)

B = flux density in tesla

N = number of secondary turns

f = system frequency in hertz

A = net core cross-sectional area in square meters

This induced voltage causes the maximum current to flow through the external burden while still maintaining a virtually sinusoidal secondary current. Any higher value of primary current demanding further increase in secondary current would, due to core saturation, tend to produce a distorted secondary current.

The circuit voltage required is typically, $E_s = I_s (Z_B + Z_S + Z_L)$

Where:

I_s = secondary current of CT in amps (assume nominal value, usually 1 A or 5 A)

Z_B = the connected external burden in ohms

Z_S = the CT secondary winding impedance in ohms

Z_L = the resistance of any associated connecting leads

In any given case several of these quantities are known or can usually be estimated to predict the performance of the transformers. From the ac magnetization characteristic, commonly plotted in secondary volts versus exciting current, E_s can be determined for a minimum exciting current. The equation for E_s given above then indicates whether the voltage required is adequate. It may be seen that the secondary burden and the maximum available fault current are two important criteria in determining the performance of a given current transformer.

The primary current contains two components. These are respectively the secondary current which is transformed in the inverse ratio of the turns ratio and an exciting current, which supplies the eddy and hysteresis losses and magnetizes the core. This latter current flows in the primary winding only and therefore, is the cause of the transformer errors. It is, therefore, not sufficient to assume a value of secondary current and to work backwards to determine the value of primary current by invoking the

constant ampere-turns rule, since this approach does not consider the exciting current. From this observation, it may be concluded that certain values of secondary current could never be produced whatever the value of primary current and this is of course, the case when the core saturates and a disproportionate amount of primary current is required to magnetize the core.

The amount of exciting current drawn by a current transformer depends on the core material and the amount of flux which must be developed in the core to satisfy the burden requirements of the current transformer. The appropriate current may be obtained directly from the exciting characteristic of the transformer since the secondary e.m.f. and therefore the flux developed is proportional to the product of secondary current and burden impedance.

The general shape of the exciting characteristic for a typical grade of CROSS core (cold rolled grain orientated silicon steel) is shown in Figure 1. The characteristic is divided into three regions, defined by ankle-point and the knee-point. The working range of a protective current transformer extends over the full range between the ankle-point and the knee-point and beyond. Protection current transformers are required to operate correctly at many times the rated current.

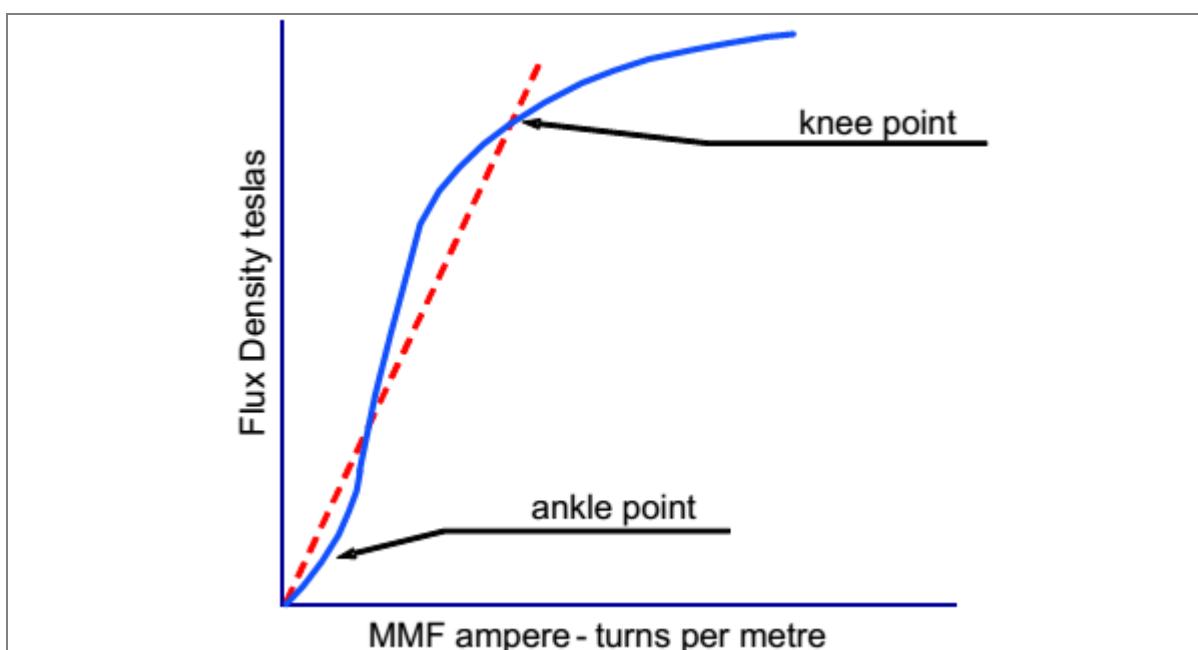

Figure1: Exciting characteristic for a CROSS core CT

The current transformer requirements for each current input will depend on the protection function with which they are related and whether the line current transformers are being shared with other current inputs. Where current transformers are being shared by multiple current inputs, the knee-point voltage requirements should be calculated for each input and the highest calculated value used.

IEC defines the knee-point of the excitation characteristic as the point at which a 10% increase in secondary voltage produces a 50% increase in exciting current. It may, therefore, be regarded as practical limit beyond which a specified current ratio may be maintained.

The current transformer magnetization curve, is usually expressed in terms of K_v , ($K_v = E_s/B$), and K_i , ($K_i = L/N$, where L is the mean magnetic path) which when multiplied by the flux density in teslas and ampere-turns per m respectively gives corresponding volts and amperes.

Warning:

The secondary circuit of a current transformer should never be left open-circuited while primary continues to flow. In these circumstances, only the primary winding is effective so the current transformer behaves as a highly saturated choke (induction) to the flow of primary winding current. Therefore, a peaky and relatively high value of voltage appears at the secondary output of terminals, endangering life, not to mention the possible resulting breakdown of secondary circuit insulation.

The errors of a current transformer may be considered as due to the whole of the primary current not being transformed, a component of which being required to excite the core. Alternatively, as shown in Figure 2, we may consider that the whole of the primary current is transformed without loss but that the secondary current is shunted by a parallel circuit. The impedance of this parallel circuit is such that the equivalent of the exciting current flows through it. The circuit shown is the equivalent circuit of the current transformer. The primary current is assumed to be transformed perfectly, with no ratio or phase angle error, to a current I_p/N which is often called 'the primary current referred to the secondary'. A part of the current may be considered consumed in exciting the core and this current I_e is called the secondary excitation current. The remainder I_s is a true secondary current. It will be evident that the excitation current is a function of the secondary excitation voltage E_s and the secondary excitation impedance Z_e . It will also be evident that the secondary current is a function of E_s and the total impedance in the secondary circuit. This total impedance consists of the effective resistance (and any leakage reactance) of the secondary winding and the impedance of the burden.

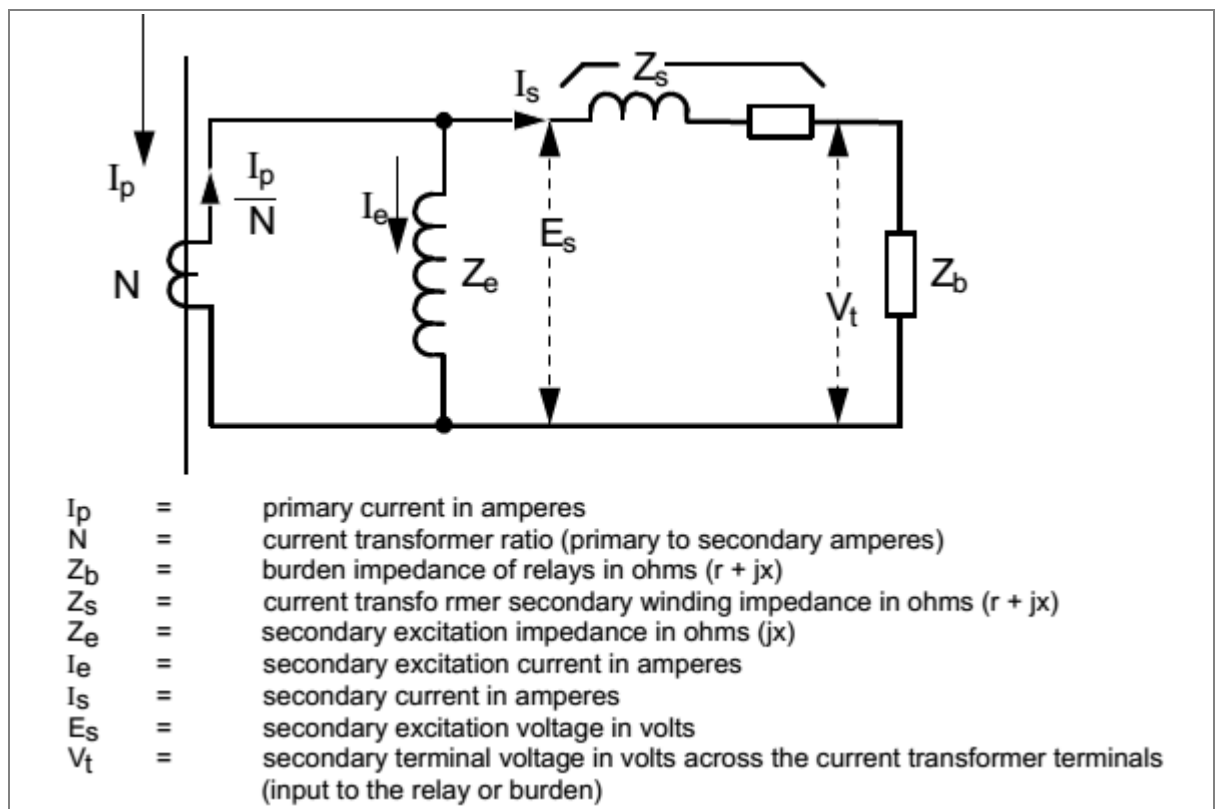

Figure 2: CT equivalent circuit

2.2 CT Requirements - Transformer Differential Protection Application

We strongly recommend Class X or Class 5P current transformers for transformer differential protection applications.

The current transformer knee-point voltage requirements are based on the following settings:

Parameter	Description	Value
Is1	This sets the minimum differential current threshold required for the transformer differential protection to trip	0.2pu
Is2	This defines the bias current threshold at which the second slope of the bias current characteristic becomes active.	2pu
K1	This setting defines the gradient of the first slope in the bias current characteristic	30%
K2	This setting defines the gradient of the second slope in the bias current characteristic	60%
Is-Hs1	This setting defines the gradient of the second slope in the bias current characteristic. This setting defines the first High set threshold on the bias current characteristic. This setting is only used in advanced mode.	10pu
Is-Hs2	This setting defines the second High set threshold on the bias current characteristic. This setting is only used in advanced mode	30pu
HV Grounding	This setting enables or disables zero sequence filtering on the HV winding	Enabled
LV Grounding	This setting enables or disables zero sequence filtering on the LV winding	Enabled
IH2 Diff Set	This setting defines the second harmonic blocking threshold	20%
Cross Blocking	This setting enables or disables cross blocking (cross blocking is where a 2nd harmonic blocking signal from any one phase, blocks all three phases).	Enabled
IH5 Diff Set	This setting defines the fifth harmonic blocking threshold	20%

A series of internal and external faults were simulated to determine the CT requirements for the differential function. Tests have been performed with different X/R ratios, CT burdens, fault currents, fault types and points on the current waveform.

To achieve through-fault stability, the K dimensioning factor must comply with the following expression:

System Condition	K	Knee point voltage (V_K)
$I_n < I_f \leq 40I_n$ $5 \leq X/R \leq 40$	2 (Refer Note)	$V_K = K \cdot I_f \cdot (I_S / I_P) \cdot (R_{CT} + 2R_L + (VA / (I_n)^2))$

Where;

V_K = knee point voltage

K = CT dimensioning factor

I_f = maximum primary fault current (A).

I_S = rated CT secondary current (A)

I_P = rated CT primary current (A)

R_{CT} = resistance of the CT secondary winding (Ohm)

R_L = resistance of a single lead from device to current transformer and additional load (W).

VA = burden of an IED current input channel (VA).

I_n = rated current of the protection IED (A)

Note: During heavy fault condition there is always chance of CT saturation. For proper operation of relay during such condition it is necessary to set HS1 setting below saturation level.

2.3 CT Requirements - Low Impedance REF Protection Application

To achieve through-fault stability, the K dimensioning factor must comply with the following expression:

System Condition	K	Knee point voltage (V_K)
$I_n < I_f \leq 40I_n$ $5 \leq X/R \leq 40$	2 (Refer Note)	$V_K = K \cdot I_f \cdot (I_S / I_P) \cdot (R_{CT} + 2R_L + (VA / (I_n)^2))$

Where;

V_K = knee point voltage

K = CT dimensioning factor

I_f = maximum primary fault current (A).

I_S = rated CT secondary current (A)

I_P = rated CT primary current (A)

R_{CT} = resistance of the CT secondary winding (Ohm)

R_L = resistance of a single lead from device to current transformer and additional load (W).

VA = burden of an IED current input channel (VA).

I_n = rated current of the protection IED (A)

Note: During heavy fault condition there is always chance of CT saturation. For proper operation of relay during such condition it is necessary to set HS1 setting below saturation level.

2.4 CT Requirements - High Impedance REF Protection Application

The guidelines for selecting knee point voltage for High Impedance REF scheme is explained below:

The general stability conditions can be obtained when:

$$V_S \geq K \cdot I_f \cdot (R_{CT} + 2R_L)$$

Where,

V_S = Stabilising voltage

K = Stability factor.

I_f = Maximum secondary external fault current.

R_{CT} = Resistance of the CT secondary winding.

R_L = Resistance of single wire from the relay to the CT

This stability factor is influenced by the ratio V_K / V_S . This in turns governs the stability of the High Impedance REF protection element for through faults.

Where V_K = the knee point voltage of the CT.

To obtain a high-speed operation for internal faults, the knee point voltage V_K of the CT must be significantly higher than stabilising voltage V_S . A ratio of 4 would be appropriate.

For P652:

$K = 1$ for V_K / V_S less or equal to 16 and

$K = 1.2$ for $V_K / V_S > 16$

A stabilizing resistor R_S is used in series with the relay circuit to improve the stability of the relay under external fault conditions. The value of R_S can be calculated using below formula:

$R_S \geq V_S / I_S$ (assuming the relay burden is negligible)

$I_S = HV$ IREF or LV IREF current setting in relay

$V_S =$ Stabilising Voltage

PROTECTION PARAMETER SETTINGS

CHAPTER 8

1 CHAPTER OVERVIEW

This chapter consists of the following sections:

- 1 Chapter Overview**
- 2 Protection Parameter Settings**
 - 2.1 System Data
 - 2.2 CB CONTROL settings
 - 2.2.1 HV CB CONTROL settings
 - 2.2.2 LV CB CONTROL settings
 - 2.3 DATE AND TIME settings
 - 2.4 CONFIGURATION settings
 - 2.5 TRANS. RATIOS settings
 - 2.6 RECORD CONTROL settings
 - 2.7 COMMUNICATION settings
 - 2.8 IO CONFIGURATION settings
 - 2.9 O/P RELAY CONFIG settings
 - 2.10 DISTURBANCE RECORD settings
 - 2.11 COMMISSION TEST settings
 - 2.12 GROUP settings
 - 2.12.1 SYSTEM CONFIG settings
 - 2.12.2 DIFF PROTECTION settings
 - 2.12.3 REF PROTECTION settings
 - 2.12.4 OVERCURRENT settings
 - 2.12.4.1 HV OVERCURRENT settings
 - 2.12.4.2 LV OVERCURRENT settings
 - 2.12.5 EARTH FAULT
 - 2.12.5.1 HV EARTH FAULT settings
 - 2.12.5.2 LV EARTH FAULT settings
 - 2.12.6 THERMAL OVERLOAD settings
 - 2.12.7 NEG SEQUENCE O/C
 - 2.12.7.1 HV NEG SEQUENCE O/C settings
 - 2.12.7.2 HV NEG SEQ O/C settings
 - 2.12.7.3 LV NEG SEQ O/C settings
 - 2.12.8 CB FAIL settings
 - 2.12.8.1 HV CB FAIL settings
 - 2.12.8.2 LV CB FAIL settings
 - 2.12.9 THROUGH FAULT settings
 - 2.12.10 VIEW RECORDS

2 PROTECTION PARAMETER SETTINGS

2.1 System Data

Sr. No	Parameter	Defaults setting	Setting / Ranges
1.	Language	English	Not editable
2.	Description	P50 Agile P652	Not editable
3.	Model Number	P652 xxxAxAxxxxA	Not editable
4.	Serial Number	xxxP652xxxx	Not editable
5.	Software Version	P652_x_x_0Vxx.xx	Not editable
6.	Frequency	50Hz	50Hz / 60Hz
This cell sets the frequency to either 50 Hz or 60 Hz.			
7.	USB Address	1	Not editable
This cell displays the address for the front USB port of the relay.			
8.	USB Parity	None	Not editable
This cell displays the parity format used in the data frames.			
9.	USB Baud rate	57600	Not editable
This cell sets the communication speed between relay and configuration tool.			
10.	Password	0000	0000 to zzzz
This cell allows you to set new password. (Alphanumeric 4- characters)			
11.	Active Group	Group 1	Not editable
This setting displays the active setting group (Group1 / Group2, whichever is selected).			
12.	Opto I/P Status	Status of the Inputs	Not editable
This setting displays the current status of Digital input			
13.	Relay O/P Status	Status of the outputs	Not editable
This setting displays the current status of Digital output			
14.	HV CB Open/Close	No Operation	No Operation / CB Open / CB Close
This setting supports open and close commands if enabled in the HV Circuit Breaker Control menu.			
15.	LV CB Open/Close	No Operation	No Operation / CB Open / CB Close
This setting supports open and close commands if enabled in the LV Circuit Breaker Control menu.			
16.	Opto I/P	DC	DC/AC
This setting allows selection of auxiliary voltage type AC/DC for opto inputs.			
17.	Config Port	USB	USB/RP
This setting allows selection of communication port for relay configuration using P50 Agile configurator. (For DNP3.0, Config Port setting is fixed as 'USB').			

2.2 CB CONTROL settings

2.2.1 HV CB CONTROL settings

Sr. No	Parameter	Defaults setting	Setting / Ranges
1.	Password	0000	0000 to zzzz
This setting specifies to enter the set password			
2.	TCS Alarm	No	Yes / No
This setting is used to enable (activate) or disable (turn off) the Trip Circuit Supervision alarm function.			
3.	TCS Timer	0.5 S	0.1s to 10s step 0.01s

Sr. No	Parameter	Defaults setting	Setting / Ranges
	This setting is used to set the time delay for the Trip Circuit supervision. If relay detects any discontinuity, then TCS alarm is generated after the set time delay.		
4.	CB Open S'vision	Enabled	Enabled / Disabled
	This setting is used to enable (activate) or disable (turn off) the CB Open Supervision function		
5.	CB Open Time	0.30 S	0.05s to 1.0s step 0.01s
	This setting is used to define the circuit breaker opening time threshold.		
6.	CB Open Alarm	Enabled	Enabled / Disabled
	This setting is used to enable (activate) or disable (turn off) the CB Open Alarm function.		
7.	CB Open Oper	2000	1 to 30000 step 1
	This setting is used to define the threshold for number of CB open operations and an alarm is issued once this threshold is crossed.		
8.	CB Control By	Disabled	Disabled / Local/Remote / Local + Remote
	This setting selects the type of circuit breaker control to be used.		
9.	Close Pulse Time	0.50 S	0.1s to 50s step 0.01s
	This setting defines duration of the close pulse within which the CB should close after a close command is issued		
10.	Open Pulse Time	0.50 S	0.1s to 50s step 0.01s
	This setting defines the duration of the trip pulse within which the CB should trip when a manual or protection trip command is issued		

2.2.2 LV CB CONTROL settings

Sr. No	Parameter	Defaults setting	Setting / Ranges
1.	Password	0000	0000 to zzzz
	This setting specifies to enter the set password		
2.	TCS Alarm	No	Yes / No
	This setting is used to enable (activate) or disable (turn off) the Trip Circuit Supervision alarm function		
3.	TCS Timer	0.5 S	0.1s to 10s step 0.01s
	This setting is used to set the time delay for the Trip Circuit supervision. If relay detects any discontinuity, then TCS alarm is generated after the set time delay.		
4.	CB Open S'vision	Enabled	Enabled / Disabled
	This setting is used to enable (activate) or disable (turn off) the CB Open Supervision function		
5.	CB Open Time	0.30 S	0.05s to 1.0s step 0.01s
	This setting is used to define the circuit breaker opening time threshold.		
6.	CB Open Alarm	Enabled	Enabled / Disabled
	This setting is used to enable (activate) or disable (turn off) the CB Open Alarm function.		
7.	CB Open Oper	2000	1 to 30000 step 1
	This setting is used to define the threshold for number of CB open operations and an alarm is issued once this threshold is crossed.		
8.	CB Control By	Disabled	Disabled / Local/Remote / Local + Remote
	This setting selects the type of circuit breaker control to be used.		
9.	Close Pulse Time	0.50 S	0.1s to 50s step 0.01s
	This setting defines duration of the close pulse within which the CB should close after a close command is issued		
10.	Open Pulse Time	0.50 S	0.1s to 50s step 0.01s
	This setting defines the duration of the trip pulse within which the CB should trip when a manual or protection trip command is issued		

2.3 DATE AND TIME settings

Sr. No	Parameter	Defaults setting	Setting / Ranges
1.	Password	0000	0000 to zzzz
	This setting specifies to enter the set password.		

Sr. No	Parameter	Defaults setting	Setting / Ranges
2.	Local Time Enable	Fixed	Fixed / Flexible / Disabled
Setting to turn on/off local time adjustments. Fixed - A local time zone adjustment can be defined using the Local Time offset setting and all interfaces will use local time. Flexible - A local time zone adjustment can be defined using the Local Time offset setting and each interface can be assigned to the UTC zone or local time zone with the exception of the local interfaces which will always be in the local time zone. Disabled - No local time zone will be maintained. Time synchronization from any interface will be used to directly set the master clock and all displayed (or read) times on all interfaces will be based on the master clock with no adjustment.			
3.	Local Time Offset	0 Mins	-720 to + 720 step 15 mins
Setting to specify an offset for local time zone from -12 to +12 hrs in 15 minute intervals. This adjustment is applied to the time based on UTC/GMT master clock.			
4.	DST Enable	Enabled	Enabled / Disabled
Setting to turn on/off daylight saving time adjustment to local time.			
5.	DST Offset	60 Mins	30 mins, 60 mins
Setting to specify daylight saving offset used for the local time adjustment.			
6.	DST Start	Last	First / Second / Third / Fourth / Last
Setting to specify the week of the month in which daylight saving time adjustment starts			
7.	DST Start Day	Sunday	Sunday / Monday / Tuesday / Wednesday / Thursday / Friday/ Saturday
Setting to specify the day of the week in which daylight saving time adjustment starts			
8.	DST Start Month	March	January / February / March / April / May / June / July / August / September / October / November / December
Setting to specify the month in which daylight saving time adjustment starts			
9.	DST Start Mins	60 Mins	0 to 1425 mins step 15mins.
Setting to specify the time of day in which daylight saving time adjustment starts. This is set relative to 00:00 hrs on the selected day when time adjustment is to start			
10.	DST End	Last	First / Second / Third / Fourth / Last
Setting to specify the week of the month in which daylight saving time adjustment ends			
11.	DST End Day	Sunday	Sunday / Monday / Tuesday / Wednesday / Thursday / Friday/ Saturday
Setting to specify the day of the week in which daylight saving time adjustment ends			
12.	DST End Month	October	January / February / March / April / May / June / July / August / September / October / November / December
Setting to specify the month in which daylight saving time adjustment ends			
13.	DST End Mins	60 Mins	0 to 1425 mins step 15mins.
Setting to specify the time of day in which daylight saving time adjustment ends. This is set relative to 00:00 hrs on the selected day when time adjustment is to end			
14.	RP Time Zone	Local	UTC / Local
Setting for the rear port 1 interface to specify if time synchronization received will be local or universal time co-ordinated.			
15.	SET Hours	11 *	0 to 23 Hrs step 1
Hour setting needed when relay is not connected to SCADA system			
16.	SET Minutes	35 *	0 to 59 Mins step 1
Minutes setting needed when relay is not connected to SCADA system			
17.	SET Seconds	54 *	0 to 59s step 1
Seconds setting needed when relay is not connected to SCADA system			
18.	SET Date	28 *	1 to 31 Days step 1
Date setting needed when relay is not connected to SCADA system			
19.	SET Month	10 *	1 to 12 Months step 1

Sr. No	Parameter	Defaults setting	Setting / Ranges
Month setting needed when relay is not connected to SCADA system			
20.	SET Year	14 *	0 to 99 Years step 1
Year setting needed when relay is not connected to SCADA system			

*Note:** The relay displays the current Date/Time set in the relay.

2.4 CONFIGURATION settings

Sr. No	Parameter	Defaults setting	Setting / Ranges
1.	Password	0000	0000 to zzzz
This setting specifies to enter the set password			
2.	Restore Defaults	No Operation	No Operation / All Settings / Setting Group 1 / Setting Group 2
<p>This setting restores the chosen setting groups to factory default values.</p> <p>To restore the default values to any Group, set the 'restore defaults' cell to the relevant Group number. Alternatively it is possible to set the 'restore defaults' cell to 'all settings' to restore the default values to all of the IED's settings, not just the Group settings.</p> <p>The default settings will be placed in Flash and will only be used by the IED after they have been confirmed by the user.</p>			
<p><i>Note:</i> Restoring defaults to all settings includes the rear communication port settings, which may result in communication via the rear port being disrupted if the new (default) settings do not match those of the master station</p>			
3.	Active Settings	Group 1	Group 1 / Group 2
This setting selects the active settings group.			
4.	Copy From	Group 1	Group 1 / Group 2
This setting allows settings to be copied from a selected setting group.			
5.	Copy To	No Operation	No Operation / Group 1 / Group 2
This command allows the displayed settings to be copied to a selected setting group.			
6.	Setting Group 1	Enabled	Enabled / Disabled
This setting enables or disables settings Group 1. If the Setting Group 1 is enabled from the configuration setting, then all associated settings and signals are available in Group 1 setting menu. If the Setting Group1 is disabled from the configuration, then all associated settings and signals are hidden, with the exception of this setting.			
7.	Setting Group 2	Disabled	Enabled / Disabled
This setting enables or disables settings Group 2. If the Setting Group 2 is enabled from the configuration setting, then all associated settings and signals are available in Group 2 setting menu. If the Setting Group 2 is disabled from the configuration, then all associated settings and signals are hidden, with the exception of this setting.			
8.	System Config	Disabled	Enabled / Disabled
This setting hides or unhides the System Config menu. Inside the 2nd Harmonic blocking related parameters are present			
	Diff Protection	Disabled	Enabled / Disabled
This setting enables or disables the Differential protection menu and it is visible further on in the Group setting menu with related parameters setting			
	REF Protection	Disabled	Disabled / Enabled
This setting enables (activate) or disables (turn off) the Restricted Earth Fault function.			
9.	HV Overcurrent	Enabled	Enabled / Disabled
This setting enables (activate) or disables (turn off) the Phase Overcurrent Protection function. If disabled, then all associated settings and signals are hidden, with the exception of this setting. Same for all other Items.			
10.	LV Overcurrent	Enabled	Enabled / Disabled

Sr. No	Parameter	Defaults setting	Setting / Ranges
			This setting enables (activate) or disables (turn off) the HV Phase Overcurrent Protection function. If disabled, then all associated settings and signals are hidden, with the exception of this setting. Same for all other Items.
11.	HV Neg Sequence O/C	Disabled	Enabled / Disabled
			This setting enables (activate) or disables (turn off) the LV Negative Sequence Overcurrent Protection.
12.	LV Neg Sequence O/C	Disabled	Enabled / Disabled
			This setting enables (activate) or disables (turn off) the LV Negative Sequence Overcurrent Protection.
13.	HV Earth Fault	Enabled	Enabled / Disabled
			This setting enables (activate) or disables (turn off) the HV Earth Fault Protection function
14.	LV Earth Fault	Enabled	Enabled / Disabled
			This setting enables (activate) or disables (turn off) the LV Earth Fault Protection function.
15.	Thermal Overload	Disabled	Enabled / Disabled
			This setting enables (activate) or disables (turn off) the Thermal Overload function.
16.	HV CB Fail	Disabled	Enabled / Disabled
			This setting enables (activate) or disables (turn off) the HV CB Fail Protection.
17.	LV CB Fail	Disabled	Enabled / Disabled
			This setting enables (activate) or disables (turn off) the LV CB Fail Protection.
18.	Through Fault	Disabled	Enabled / Disabled
			This setting enables (activate) or disables (turn off) through-fault current monitoring.
19.	Measure't Setup	ABC	ABC /RYB
			This setting determines the representation of Phases. Based on this setting, the representation in measurements, records etc shall change. No change is expected for the stored records (if any).
20.	Setting Values	Secondary	Primary/Secondary
			This setting determines the reference for all settings dependent on the transformer ratios; either referenced to the primary or the secondary.
21.	Measure't Values	Secondary	Primary/Secondary
			This setting determines to display the Measured values with respect to CT secondary or primary. Based on this setting the representation in measurements shall change in the relay.

2.5 TRANS. RATIOS settings

Sr. No	Parameter	Defaults setting	Setting / Ranges
1.	Password	0000	0000 to zzzz
			This setting specifies to enter the set password
2.	HV Ph CT Prim'y	500A	1 to 30000A step 1A
			This setting determines the phase current transformer input primary current rating for HV side
3.	HV Ph CT Sec'y	1 A	1A or 5 A (non editable -as per ordering option)
			This setting determines the phase current transformer input secondary current rating for HV side.
4.	LV Ph CT Prim'y	800A	1 to 30000A step 1A
			This setting determines the phase current transformer input primary current rating for LV side
5.	LV Ph CT Sec'y	1 A	1A or 5 A (non editable -as per ordering option)
			This setting determines the phase current transformer input secondary current rating for LV side.
6.	HV REF CT Prim'y	100A	1 to 30000A step 1A
			This setting determines the REF current transformer input primary current rating for HV side
7.	HV REF CT Sec'y	1 A	1A or 5 A
			This setting determines the REF current transformer input secondary current rating for HV side.
8.	LV REF CT Prim'y	100A	1 to 30000A step 1A

Sr. No	Parameter	Defaults setting	Setting / Ranges
This setting determines the REF current transformer input primary current rating for LV side			
9.	LV REF CT Sec'y	1 A	1A or 5 A
This setting determines the REF current transformer input secondary current rating for LV side.			

2.6 RECORD CONTROL settings

Sr. No	Parameter	Defaults setting	Setting / Ranges
1.	Password	0000	0000 to zzzz
This setting specifies to enter the set password			
2.	Clear Events	No	Yes / No
Selecting "Yes" will erase the existing events stored in the relay.			
3.	Clear Faults	No	Yes / No
Selecting "Yes" will erase the existing fault records from the relay.			
4.	Clear Dist Recs	No	Yes / No
Selecting "Yes" will erase the existing disturbance records from the relay.			
5.	Clear Maint	No	Yes / No
Selecting "Yes" will erase the existing maintenance records from the relay.			
6.	Reset HV CB Data	No	Yes / No
Selecting "Yes" will erase the existing HV CB data from the relay.			
7.	Reset LV CB Data	No	Yes / No
Selecting "Yes" will erase the existing LV CB data from the relay.			
8.	Thermal Reset	No	Yes / No
Selecting "Yes" will reset the existing thermal state to zero.			

2.7 COMMUNICATION settings

Sr. No	Parameter	Defaults setting	Setting / Ranges
1.	Password	0000	0000 to zzzz
This setting specifies to enter the set password			
2.	RP1 Address	1	1 to 247 step 1
This setting sets the address of RP1.			
3.	RP1 Baud rate	57600	9600 / 19200 / 38400 / 57600
This cell sets the communication speed between relay and master station. It is important that both relay and master station are set at the same speed setting.			
4.	RP1 Parity	Even	Even / Odd / None
This cell sets the parity format used in the data frames. It is important that both relay and master station are set with the same parity setting.			
5.	RP1 Timesync	Disabled	Enabled / Disabled
This setting enables or disables time synchronization with master clock			

2.8 IO CONFIGURATION settings

Sr. No	Parameter	Defaults setting	Setting / Ranges
1.	Password	0000	0000 to zzzz
This setting specifies to enter the set password			
2.	Relay Gen Strt*	654321 000000	6→ RL6.....1→RL1 1 = assigned ; 0 = not assigned

Sr. No	Parameter	Defaults setting	Setting / Ranges
This cell sets the output contact RL1 – RL6 for desired function.			
3.	LED G Gen Strt*	8765 0000	8→ LED8.....5→LED5 1 = assigned ; 0 = not assigned
This cell sets the Green LED L5 – L8 for desired function.			
4.	LED R Gen Strt*	8765 0000	8→ LED L8.....5→LED L5 1 = assigned ; 0 = not assigned
This cell sets the RED LED L5 – L8 for desired function.			
5.	AND Logic Gen Strt*	DCBA 0000	D→ AND Logic D.....A→ AND Logic A 1 = assigned ; 0 = not assigned
This cell sets the input for AND Logic equation (A, B, C and D).			
6.	Opto I/P Rem.Rst*	654321 000000	6→ S6.....1→S1 1 = assigned ; 0 = not assigned
This cell sets the Opto I/P 1 – Opto I/P 6 for desired function.			

Note: The functions which can be assigned to Output Relay, LED Green, LED RED, AND Logic and Opto I/P are listed in **Chapter 8: Monitoring and Control.*

2.9 O/P RELAY CONFIG settings

Sr. No	Parameter	Defaults setting	Setting / Ranges
1.	Password	0000	0000 to zzzz
This setting specifies to enter the set password			
2.	Contact HR/SR	000000	1= HR / 0 = SR
This setting specifies the reset mechanism (manual / hand reset or self reset) for O/P relay contacts.			
3.	O/P-1 Open Time	0.05 S	0s to 1s step 0.01s
4.	O/P-2 Open Time	0.05 S	0s to 1s step 0.01s
5.	O/P-3 Open Time	0.05 S	0s to 1s step 0.01s
6.	O/P-4 Open Time	0.05 S	0s to 1s step 0.01s
7.	O/P-5 Open Time	0.05 S	0s to 1s step 0.01s
8.	O/P-6 Open Time	0.05 S	0s to 1s step 0.01s
This setting specifies the time duration for which the output contacts holds its state after non availability of the command to the O/P contact.			
9.	LED G HR/SR	0000	1= HR / 0 = SR
This setting specifies the reset mechanism (manual/hand reset or self reset) for Green LED.			
10.	LED R HR/SR	0000	1= HR / 0 = SR
This setting specifies the reset mechanism (manual/hand reset or self reset) for RED LED.			
11.	ANDEQ A Op Time	1 S	1s to 3600s step 1s
12.	ANDEQ A Rst Time	1 S	1s to 3600s step 1s
13.	ANDEQ B Op Time	1 S	1s to 3600s step 1s
14.	ANDEQ B Rst Time	1 S	1s to 3600s step 1s
15.	ANDEQ C Op Time	1 S	1s to 3600s step 1s
16.	ANDEQ C Rst Time	1 S	1s to 3600s step 1s
17.	ANDEQ D Op Time	1 S	1s to 3600s step 1s
18.	ANDEQ D Rst Time	1 S	1s to 3600s step 1s

Sr. No	Parameter	Defaults setting	Setting / Ranges
These settings specifies the operating / reset time delay allocated to the logic AND equation.			

Note: In P50 Agile Configurator, the above settings parameters from serial no. 9 to 18 are available under "IO Mask".

2.10 DISTURBANCE RECORD settings

Sr. No	Parameter	Defaults setting	Setting / Ranges
1.	Password	0000	0000 to zzzz
This setting specifies to enter the set password			
2.	Trigger Position	50%	10% to 90% step 1%
This setting sets the trigger point as a percentage of the duration. For example, the default setting, which is set to 50% (of 1.0s) gives 0.5s pre-fault and 0.5s post-fault recording times.			

2.11 COMMISSION TEST settings

Sr. No	Parameter	Defaults setting	Setting / Ranges
1.	Password	0000	0000 to zzzz
This setting specifies to enter the set password			
2.	Test Mode	Disabled	Disabled, Test Mode, Contacts Blocked
This setting allows secondary injection testing to be performed on the relay itself.			
3.	Test Pattern	000000	0 = not operated , 1 = operated
This setting is used to select the output relay contacts that will be tested when the Contact Test cell is set to Apply Test.			
4.	Contact Test	No Operation	No Operation, Apply Test, Remove Test
This setting is used to test the relay output contact operation.			
5.	Test LEDs	No Operation	No Operation / Apply Test
This setting is used to test the 4 no's programmable LED's.			

2.12 GROUP settings

The following settings are common to GROUP 1 and 2.

2.12.1 SYSTEM CONFIG settings

Sr. No	Parameter	Default setting	Setting Range
1.	HV Connection	Y-Wye	Y-Wye, D-Delta
This setting defines the power transformer's HV winding connection type.			
2.	HV Grounding	Grounded	Grounded or Ungrounded
This setting defines whether the winding is earthed or not earthed. It is used to decide whether zero sequence filtering is required or not Grounded = zero sequence filtering required Ungrounded = zero sequence filtering not required			
3.	HV Nominal Range	KV	V / KV
This setting is used to set the range of HV nominal voltage in KV or V. If the nominal voltage is less than 1000 V then V can be selected, otherwise KV should be selected.			
4.	HV Nominal	11kV*	1.0 kV to 1000.0 kV step 0.1kV
This setting determines the voltage of the HV winding, mid-tap voltage of the on-load tap changer, or no-load tap changer tap voltage. *This setting is visible only if HV Nominal Range is set as KV			

Sr. No	Parameter	Default setting	Setting Range
5.	HV Nominal	415V*	1 to 1000V step 1V
This setting determines the voltage of the HV winding, mid-tap voltage of the on-load tap changer, or no-load tap changer tap voltage. *This setting is visible only if HV Nominal Range is set as V.			
6.	Trafo Rating	10MVA	0.1 MVA to 3000 MVA step 0.1 MVA
This setting is used to set the MVA rating of Transformer.			
7.	LV Vector Group	0	0 to 11 step 1
This setting defines the vector group of the LV winding with respect to the reference vector group. It is used to correct the phase shift between HV and LV windings.			
8.	LV Connection	Y-Wye	Y-Wye, D-Delta or Z-Zigzag
This setting defines the power transformer's LV winding connection type.			
9.	LV Grounding	Grounded	Grounded or Ungrounded
This setting defines whether the winding is earthed or not earthed. It is used to decide whether zero sequence filtering is required or not. Grounded = zero sequence filtering required Ungrounded = zero sequence filtering not required			
10.	LV Nominal Range	KV	V/KV
This setting is used to set the range of LV nominal voltage interims of kV or V. if the nominal voltage is less than 1000 V then V can be selected, otherwise should select as kV.			
11.	LV Nominal	11kV*	1.0 k to 1000.0 kV step 0.1kV
This setting determines the voltage of the LV winding, mid-tap voltage of the on-load tap changer, or no-load tap changer tap voltage. *This setting is visible only if LV Nominal Range is set as kV			
12.	HV Nominal	415V*	1 to 1000V step 1V
This setting determines the voltage of the LV winding, mid-tap voltage of the on-load tap changer, or no-load tap changer tap voltage. *This setting is visible only if LV Nominal Range is set as V			
13.	HV Match Factor	Set by relay	Read Only
This cell displays the CT1 ratio correction factor used by the differential function.			
14.	LV Match Factor	Set by relay	Read Only
This cell displays the CT2 ratio correction factor used by the differential function.			
15.	HV Iref	Set by relay	Read Only
The reference current for HV winding of the protected object is calculated by the relay			
16.	LV Iref	Set by relay	Read Only
The reference current for LV winding of the protected object is calculated by the relay			
17.	IH2 HV Prot'n	Disabled	Disabled / Enabled
This setting enables or disables the 2nd Harmonic blocking of the HV overcurrent protection.			
18.	IH2 HV Set	20%	From 5% to 70% step 1%
If the level of 2nd harmonic/fundamental in any phase current or neutral current exceeds the setting, the overcurrent protection will be blocked as selected.			
19.	>lift 2H HV	10*In	From 4*In to 32*In step 0.01*In
The 2nd harmonic blocking is applied only when the fundamental current is above 2nd Harm Thresh and below > lift 2H HV setting. The reset levels are 95% of these thresholds.			
20.	IH2 LV Prot'n	Disabled	Disabled / Enabled
This setting enables or disables the 2nd Harmonic blocking of the LV overcurrent protection.			
21.	IH2 LV Set	20%	From 5% to 70% step 1%
If the level of 2nd harmonic/fundamental in any phase current or neutral current exceeds the setting, the overcurrent protection will be blocked as selected.			
22.	>lift 2H LV	10*In	From 4*In to 32*In step 0.01*In

Sr. No	Parameter	Default setting	Setting Range
The 2nd harmonic blocking is applied only when the fundamental current is above 2nd Harm Thresh and below I> lift 2H LV setting. The reset levels are 95% of these thresholds.			

2.12.2 DIFF PROTECTION settings

Sr. No	Parameter	Default setting	Setting Range
1.	DIFF PROTECTION	Enabled	Disabled / Enabled
To enable (activate) or disable (turn off) the Differential Protection.			
2.	Is1	0.2 pu	0.1pu to 2.5pu step 0.01 pu
This sets the minimum differential current threshold required for the transformer differential protection to trip.			
3.	K1	30%	0% to 150% step of 1%
This setting defines the gradient of the first slope in the bias current characteristic			
4.	Is2	1 pu	1.5 pu to 10 pu step 0.1 pu
This defines the bias current threshold at which the second slope of the bias current characteristic becomes active.			
5.	K2	80%	15% to 150% steps of 1%
This setting defines the gradient of the second slope in the bias current characteristic			
6.	IH2 Diff Block	Disabled	Disabled / Enabled
This setting enables or disables second harmonic blocking			
7.	IH2 Diff Set	20%	From 5% to 70% step 1%
If the level of 2nd harmonic/fundamental in any phase current or neutral current exceeds the setting, the Differential protection will be blocked. This setting is visible only when IH2 Diff Block is enabled			
8.	Cross Blocking	Enabled	Disabled / Enabled
This setting is used to enable or disable the cross blocking function. This setting is visible only when IH2 Diff Block is enabled			
9.	IH5 Diff Block	Disabled	Disabled / Enabled
This setting enables or disables fifth harmonic blocking			
10.	IH5 Diff Set	20%	From 5% to 70% step 1%
If the level of 5th harmonic/fundamental in any phase current or neutral current exceeds the setting, the Differential protection will be blocked. This setting is visible only when IH5 Diff Block is enabled			
11.	tDiff	0 S	0s to 10s step 0.01s
This sets the time delay for the transformer differential protection			
12.	Is-HS1	10 pu	0.5pu to 30pu step 0.1pu
This setting defines the first High set threshold on the bias current characteristics. If the differential current is above the adjustable Is-HS1 threshold, the device will trip if in the Operate region, but not in the restrain region regardless of harmonic blocking.			
13.	Is-HS2	10.00pu	0.5pu to 30pu step 0.1pu
This setting defines the second High set threshold on the bias current characteristic. If the differential current is above the adjustable Is-HS2 threshold, bias current is not taken into account and the device will trip.			

2.12.3 REF PROTECTION settings

Sr. No	Parameter	Default setting	Setting Range
HV REF			
1.	REF status	LowZ REF	Disabled, LowZ REF or HighZ REF
This setting disables REF or selects the type of REF (Low Impedance or High Impedance) for the HV winding. Based on selection of REF status only relevant settings are visible.			
2.	Is1 Set	0.1 pu	0.05pu to 1pu step 0.01pu
This sets the minimum differential current required for the HV REF protection to trip. This setting is visible only when REF status is selected as LowZ REF.			
3.	Is2 Set	0.1 pu	0.1pu to 10pu step 0.1pu

Sr. No	Parameter	Default setting	Setting Range
This defines the bias current threshold at which the second slope of the bias current characteristic becomes active for the HV REF protection. This setting is visible only if REF status is selected as LowZ REF.			
4.	IREF K1	0%	0% to 150% step 1%
This setting defines the gradient of the first slope in the bias current characteristic for the HV REF protection. This setting is visible only if REF status is selected as LowZ REF.			
5.	IREF K2	150%	15% to 150% step 1%
This setting defines the gradient of the second slope in the bias current characteristic for the HV REF protection. This setting is visible only if REF status is selected as LowZ REF.			
6.	tREF	0s	0s to 10s step 0.01s
This sets the time delay for the HV REF protection element. This setting is visible only if REF status is selected as LowZ REF.			
7.	IREF Is	0.09	0.05In to 1In step 0.01In
This sets minimum differential threshold of the HV HighZ REF protection. This setting is visible only if REF status is selected as HighZ REF.			
8.	IH2 REF Block	Disabled	Enabled or Disabled
This setting enables or disables second harmonic blocking for the HV element. This setting is visible only if REF HV status is selected as HighZ REF or LowZ REF.			
9.	IH2 REF Set	20%	From 5% to 70% step 1%
This setting is used to set 2nd harmonic threshold.			
LV REF			
10.	REF status	Disabled	Disabled, LowZ REF or HighZ REF
This setting disables REF or selects the type of REF (Low Impedance or High Impedance) for the LV winding. Based on selection of REF status, only the relevant settings are visible.			
11.	Is1 Set	0.1 pu	0.05pu to 1pu step 0.01 pu
This sets the minimum differential current required for the LV REF protection to trip. This setting is visible only if REF status is selected as LowZ REF.			
12.	Is2 Set	0.1 pu	0.1pu to 10pu step 0.1 pu
This defines the bias current threshold at which the second slope of the bias current characteristic becomes active for the LV REF protection. This setting is visible only if REF status is selected as LowZ REF.			
13.	IREF K1	0	0% to 150% step 1%
This setting defines the gradient of the first slope in the bias current characteristic for the LV REF protection. This setting is visible only if REF status is selected as LowZ REF.			
14.	IREF K2	150%	15% to 150% step 1%
This setting defines the gradient of the second slope in the bias current characteristic for the LV REF protection. This setting is visible only if REF status is selected as LowZ REF.			
15.	tREF	0s	0s to 10s step 0.01s
This sets the time delay for the LV REF protection element. This setting is visible only if REF LV status is selected as LowZ REF.			
16.	IREF Is	0.09	0.02In to 1In step 0.01In
This sets the minimum differential threshold of the LV HighZ REF protection. This setting is visible only if REF status is selected as HighZ REF.			
17.	IH2 REF Block	Disabled	Enabled or Disabled
This setting enables or disables second harmonic blocking for the LV element. This setting is visible only if REF status is selected as HighZ REF or LowZ REF.			
18.	IH2 REF Set	20%	From 5% to 70% step 1%
This setting is used to set 2nd harmonic threshold.			

2.12.4 OVERCURRENT settings

2.12.4.1 HV OVERCURRENT settings

2.12.4.1.1 I>1 Function

Sr. No	Parameter	Default setting	Setting Range
1.	I>1 Function	IEC S Inverse	Disabled / DT / IEC S Inverse / S Inverse / 1.3Sec / IEC V Inverse / IEC E Inverse / UK LT Inverse / IEEE M Inverse / IEEE V Inverse / IEEE E Inverse / US Inverse / US ST Inverse
This setting determines the tripping characteristic for the first stage overcurrent element.			
2.	I>1 Current Set	1.00*In	If DT 0.05 to 35.00*In step 0.01*In If IDMT 0.05 to 4.00*In step 0.01*In
This setting determines the pick-up setting for first stage overcurrent element.			
3.	I>1 Time Delay	1.00 S	0s to 100s step 0.01s
This setting determines the time-delay for the definite time setting if selected for first stage overcurrent element.			
4.	I>1 TMS	1.000	0.025 to 1.2 step 0.005
This time multiplier setting is used to adjust the operating time of the IEC / UK IDMT characteristic.			
5.	I>1 Time Dial	1.00	0.01 to 100 step 0.01s
This time multiplier setting is used to adjust the operating time of the IEEE / US IDMT curves.			
6.	I>1 Reset Char	DT	DT/IDMT
This setting determines the type of reset/release characteristics. IDMT applicable for IEEE / US curves only.			
7.	I>1 RTMS	1.000	0.025 to 1.2 step 0.005
This setting determines the reset/release time for IEEE IDMT characteristic			
8.	I>1 tRESET	0.01 S	0s to 100s step 0.01s
This setting determines the reset/release time for Definite Time (DT) and all IDMT curve			
9.	I>1 2H Blocking	Disabled	Enabled / Disabled
This setting enables/disables blocking of first stage HV overcurrent element due to presence of inrush current. If I>1 2H Blocking and IH2 HV Prot'n settings are enabled, then (I>1) trip command will be blocked in case 2nd harmonic content in any phase is above the IH2 HV Set and fundamental current is below I> lift 2H HV setting . (Set in SYSTEM CONFIG menu)			

2.12.4.1.2 I>2 Function

Sr. No	Parameter	Default setting	Setting Range
1.	I>2 Function	IEC S Inverse	Disabled / DT / IEC S Inverse / S Inverse / 1.3Sec / IEC V Inverse / IEC E Inverse / UK LT Inverse / IEEE M Inverse / IEEE V Inverse / IEEE E Inverse / US Inverse / US ST Inverse
This setting determines the tripping characteristic for the second stage overcurrent element.			
2.	I>2 Current Set	1.00*In	If DT 0.05 to 35.00*In step 0.01*In If IDMT 0.05 to 4.00*In step 0.01*In
This setting determines the pick-up setting for second stage overcurrent element.			
3.	I>2 Time Delay	1.00 S	0s to 100s step 0.01s
This setting determines the time-delay for the definite time setting if selected for second stage overcurrent element.			
4.	I>2 TMS	1.000	0.025 to 1.2 step 0.005
This time multiplier setting is used to adjust the operating time of the IEC / UK IDMT characteristic.			

Sr. No	Parameter	Default setting	Setting Range
5.	I>2 Time Dial	1.00	0.01 to 100 step 0.01
This time multiplier setting is used to adjust the operating time of the IEEE / US IDMT curves.			
6.	I>2 Reset Char	DT	DT/IDMT
This setting determines the type of reset/release characteristics. IDMT applicable for IEEE / US curves only.			
7.	I>2 RTMS	1.000	0.025 to 1.2 step 0.005
This setting determines the reset/release time for IEEE IDMT characteristic			
8.	I>2 tRESET	0.01 S	0s to 100s step 0.01s
This setting determines the reset/release time for Definite Time (DT) and all IDMT curve			
9.	I>2 2H Blocking	Disabled	Enabled / Disabled
This setting enables/disables blocking of second stage HV overcurrent element due to presence of inrush current. If I>2 2H Blocking and IH2 HV Prot'n settings are enabled, then (I>2) trip command will be blocked in case 2nd harmonic content in any phase is above the IH2 HV Set and fundamental current is below I> lift 2H HV setting . (Set in SYSTEM CONFIG menu)			

2.12.4.1.3 I>3 Function

Sr. No	Parameter	Default setting	Setting Range
1.	I>3 Function	IEC S Inverse	Disabled / DT / IEC S Inverse / S Inverse 1.3Sec / IEC V Inverse / IEC E Inverse / UK LT Inverse / IEEE M Inverse / IEEE V Inverse / IEEE E Inverse / US Inverse / US ST Inverse
This setting determines the tripping characteristic for the third stage overcurrent element.			
2.	I>3 Current Set	1.00*In	If DT 1.0 to 35.00*In step 0.01*In If IDMT 0.05 to 4.00*In step 0.01*In
This setting determines the pick-up setting for second third overcurrent element.			
3.	I>3 Time Delay	1.00 S	0s to 100s step 0.01s
This setting determines the time-delay for the definite time setting if selected for third stage overcurrent element.			
4.	I>3 TMS	1.000	0.025 to 1.2 step 0.005
This time multiplier setting is used to adjust the operating time of the IEC / UK IDMT characteristic.			
5.	I>3 Time Dial	1.00	0.01 to 100 step 0.01s
This time multiplier setting is used to adjust the operating time of the IEEE / US IDMT curves.			
6.	I>3 Reset Char	DT	DT/IDMT
This setting determines the type of reset/release characteristics. IDMT applicable for IEEE / US curves only.			
7.	I>3 RTMS	1.000	0.025 to 1.2 step 0.005
This setting determines the reset/release time for IEEE IDMT characteristic			
8.	I>3 tRESET	0.01 S	0s to 100s step 0.01s
This setting determines the reset/release time for Definite Time (DT) and all IDMT curve			
9.	I>3 2H Blocking	Disabled	Enabled / Disabled
This setting enables/disables blocking of third stage HV overcurrent element due to presence of inrush current. If I>3 2H Blocking and IH2 HV Prot'n settings are enabled, then (I>3) trip command will be blocked in case 2nd harmonic content in any phase is above the IH2 HV Set and fundamental current is below I> lift 2H HV setting . (Set in SYSTEM CONFIG menu)			

2.12.4.2 LV OVERCURRENT settings

2.12.4.2.1 I>1 Function

Sr. No	Parameter	Default setting	Setting Range
1.	I>1 Function	IEC S Inverse	Disabled / DT / IEC S Inverse / S Inverse / 1.3Sec / IEC V Inverse / IEC E Inverse / UK LT Inverse / IEEE M Inverse / IEEE V Inverse / IEEE E Inverse / US Inverse / US ST Inverse
This setting determines the tripping characteristic for the first stage overcurrent element.			
2.	I>1 Current Set	1.00*In	If DT 0.05 to 35.00*In step 0.01*In If IDMT 0.05 to 4.00*In step 0.01*In
This setting determines the pick-up setting for first stage overcurrent element.			
3.	I>1 Time Delay	1.00 S	0s to 100s step 0.01s
This setting determines the time-delay for the definite time setting if selected for first stage overcurrent element.			
4.	I>1 TMS	1.000	0.025 to 1.2 step 0.005
This time multiplier setting is used to adjust the operating time of the IEC / UK IDMT characteristic.			
5.	I>1 Time Dial	1.00	0.01 to 100 step 0.01s
This time multiplier setting is used to adjust the operating time of the IEEE / US IDMT curves.			
6.	I>1 Reset Char	DT	DT/IDMT
This setting determines the type of reset/release characteristics. IDMT applicable for IEEE / US curves only.			
7.	I>1 RTMS	1.000	0.025 to 1.2 step 0.005
This setting determines the reset/release time for IEEE IDMT characteristic			
8.	I>1 tRESET	0.01 S	0s to 100s step 0.01s
This setting determines the reset/release time for Definite Time (DT) and all IDMT curve			
9.	I>1 2H Blocking	Disabled	Enabled / Disabled
This setting enables/disables blocking of first stage LV overcurrent element due to presence of inrush current. If I>1 2H Blocking and IH2 LV Prot'n settings are enabled, then (I>1) trip command will be blocked in case 2nd harmonic content in any phase is above the IH2 LV Set and fundamental current is below I> lift 2H LV setting . (Set in SYSTEM CONFIG menu)			

2.12.4.2.2 I>2 Function

Sr. No	Parameter	Default setting	Setting Range
1.	I>2 Function	IEC S Inverse	Disabled / DT / IEC S Inverse / S Inverse / 1.3Sec / IEC V Inverse / IEC E Inverse / UK LT Inverse / IEEE M Inverse / IEEE V Inverse / IEEE E Inverse / US Inverse / US ST Inverse
This setting determines the tripping characteristic for the second stage overcurrent element.			
2.	I>2 Current Set	1.00*In	If DT 0.05 to 35.00*In step 0.01*In If IDMT 0.05 to 4.00*In step 0.01*In
This setting determines the pick-up setting for second stage overcurrent element.			
3.	I>2 Time Delay	1.00 S	0s to 100s step 0.01s
This setting determines the time-delay for the definite time setting if selected for second stage overcurrent element.			
4.	I>2 TMS	1.000	0.025 to 1.2 step 0.005
This time multiplier setting is used to adjust the operating time of the IEC / UK IDMT characteristic.			
5.	I>2 Time Dial	1.00	0.01 to 100 step 0.01
This time multiplier setting is used to adjust the operating time of the IEEE / US IDMT curves.			

Sr. No	Parameter	Default setting	Setting Range
6.	I>2 Reset Char	DT	DT/IDMT
This setting determines the type of reset/release characteristics. IDMT applicable for IEEE / US curves only.			
7.	I>2 RTMS	1.000	0.025 to 1.2 step 0.005
This setting determines the reset/release time for IEEE IDMT characteristic			
8.	I>2 tRESET	0.01 S	0s to 100s step 0.01s
This setting determines the reset/release time for Definite Time (DT) and all IDMT curve			
9.	I>2 2H Blocking	Disabled	Enabled / Disabled
This setting enables/disables blocking of second stage LV overcurrent element due to presence of inrush current. If I>2 2H Blocking and IH2 LV Prot'n settings are enabled, then (I>2) trip command will be blocked in case 2nd harmonic content in any phase is above the IH2 LV Set and fundamental current is below I> lift 2H LV setting . (Set in SYSTEM CONFIG menu)			

2.12.4.2.3 I>3 Function

Sr. No	Parameter	Default setting	Setting Range
1.	I>3 Function	IEC S Inverse	Disabled / DT / IEC S Inverse / S Inverse / 1.3Sec / IEC V Inverse / IEC E Inverse / UK LT Inverse / IEEE M Inverse / IEEE V Inverse / IEEE E Inverse / US Inverse / US ST Inverse
This setting determines the tripping characteristic for the third stage overcurrent element.			
2.	I>3 Current Set	1.00*In	If DT 1.0 to 35.00*In step 0.01*In If IDMT 0.05 to 4.00*In step 0.01*In
This setting determines the pick-up setting for second third overcurrent element.			
3.	I>3 Time Delay	1.00 S	0s to 100s step 0.01s
This setting determines the time-delay for the definite time setting if selected for third stage overcurrent element.			
4.	I>3 TMS	1.000	0.025 to 1.2 step 0.005
This time multiplier setting is used to adjust the operating time of the IEC / UK IDMT characteristic.			
5.	I>3 Time Dial	1.00	0.01 to 100 step 0.01s
This time multiplier setting is used to adjust the operating time of the IEEE / US IDMT curves.			
6.	I>3 Reset Char	DT	DT/IDMT
This setting determines the type of reset/release characteristics. IDMT applicable for IEEE / US curves only.			
7.	I>3 RTMS	1.000	0.025 to 1.2 step 0.005
This setting determines the reset/release time for IEEE IDMT characteristic			
8.	I>3 tRESET	0.01 S	0s to 100s step 0.01s
This setting determines the reset/release time for Definite Time (DT) and all IDMT curve			
9.	I>3 2H Blocking	Disabled	Enabled / Disabled
This setting enables/disables blocking of third stage LV overcurrent element due to presence of inrush current. If I>3 2H Blocking and IH2 LV Prot'n settings are enabled, then (I>3) trip command will be blocked in case 2nd harmonic content in any phase is above the IH2 LV Set and fundamental current is below I> lift 2H LV setting . (Set in SYSTEM CONFIG menu)			

2.12.5 EARTH FAULT

2.12.5.1 HV EARTH FAULT settings

2.12.5.1.1 IN>1 Function

Sr. No	Parameter	Default setting	Setting Range
1.	HV EARTH FAULT	Derived	Derived/Measured

Sr. No	Parameter	Default setting	Setting Range
This setting is used to set the earth fault as derived or measured. Note : Measured E/F should not be selected if HV HighZ REF protection is enabled.			
1.	IN>1 Function	IEC S Inverse	Disabled / DT / IEC S Inverse / S Inverse 1.3Sec / IEC V Inverse / IEC E Inverse / UK LT Inverse / IEEE M Inverse / IEEE V Inverse / IEEE E Inverse / US Inverse / US ST Inverse
This setting determines the tripping characteristic for the first stage measured earth fault element.			
2.	IN>1 Current Set	1.00*In	If DT 0.1 to 35.00*In step 0.01*In If IDMT 0.1 to 4.00*In step 0.01*In
This setting determines the pick-up setting for first stage measured earth fault element.			
3.	IN>1 Time Delay	1.00 S	0s to 200s step 0.01s
This setting determines the time-delay for the definite time setting if selected for first stage of measured earth fault element.			
4.	IN>1 TMS	1.000	0.025 to 1.2 step 0.005
This time multiplier setting is used to adjust the operating time of the IEC / UK IDMT characteristic.			
5.	IN>1 Time Dial	1.00	0.01 to 100 step 0.01
This time multiplier setting is used to adjust the operating time of the IEEE / US IDMT curves.			
6.	IN>1 Reset Char	DT	DT/IDMT
This setting determines the type of reset/release characteristics. IDMT applicable for IEEE / US curves only.			
7.	IN>1 RTMS	1.000	0.025 to 1.2 step 0.005
This setting determines the reset/release time for IEEE IDMT characteristic			
8.	IN>1 tRESET	0.01 S	0s to 100s step 0.01s
This setting determines the reset/release time for Definite Time (DT) and all IDMT curve			
9.	IN>1 2H Blocking	Disabled	Enabled / Disabled
This setting enables/disables blocking of first stage HV earth fault element due to presence of inrush current. If IN>1 2H Blocking and IH2 HV Prot'n settings are enabled, then (IN>1) trip command will be blocked in case 2nd harmonic content is above the IH2 HV Set and fundamental current is below I> lift 2H HV setting . (Set in SYSTEM CONFIG menu)			

2.12.5.1.2 IN>2 Function

Sr. No	Parameter	Default setting	Setting Range
1.	IN>2 Function	IEC S Inverse	Disabled / DT / IEC S Inverse / S Inverse 1.3Sec / IEC V Inverse / IEC E Inverse / UK LT Inverse / IEEE M Inverse / IEEE V Inverse / IEEE E Inverse / US Inverse / US ST Inverse
This setting determines the tripping characteristic for the second stage measured earth fault element.			
2.	IN>2 Current Set	1.00*In	If DT 0.1 to 35.00*In step 0.01*In If IDMT then 0.1 to 4.00*In step 0.01*In
This setting determines the pick-up setting for second stage measured earth fault element.			
3.	IN>2 Time Delay	1.00 S	0s to 200s step 0.01s
This setting determines the time-delay for the definite time setting if selected for second stage of measured earth fault element.			
4.	IN>2 TMS	1.000	0.025 to 1.2 step 0.005
This time multiplier setting is used to adjust the operating time of the IEC / UK IDMT characteristic.			
5.	IN>2 Time Dial	1.00	0.01 to 100 step 0.01
This time multiplier setting is used to adjust the operating time of the IEEE / US IDMT curves.			
6.	IN>2 Reset Char	DT	DT/IDMT
This setting determines the type of reset/release characteristics. IDMT applicable for IEEE / US curves only.			

Sr. No	Parameter	Default setting	Setting Range
7.	IN>2 RTMS	1.000	0.025 to 1.2 step 0.005
This setting determines the reset/release time for IEEE IDMT characteristic			
8.	IN>2 tRESET	0.01 S	0s to 100s step 0.01s
This setting determines the reset/release time for Definite Time (DT) and all IDMT curve			
9.	IN>2 2H Blocking	Disabled	Enabled / Disabled
This setting enables/disables blocking of second stage HV earth fault element due to presence of inrush current. If IN>2 2H Blocking and IH2 HV Prot'n settings are enabled, then (IN>2) trip command will be blocked in case 2nd harmonic content is above the IH2 HV Set and fundamental current is below I> lift 2H HV setting . (Set in SYSTEM CONFIG menu)			

2.12.5.1.3 IN>3 Function

Sr. No	Parameter	Default setting	Setting Range
1.	IN>3 Function	IEC S Inverse	Disabled / DT / IEC S Inverse / S Inverse 1.3Sec / IEC V Inverse / IEC E Inverse / UK LT Inverse / IEEE M Inverse / IEEE V Inverse / IEEE E Inverse / US Inverse / US ST Inverse
This setting determines the tripping characteristic for the third stage measured earth fault element.			
2.	IN>3 Current Set	01.00*In	If DT 1.0 to 35.00*In step 0.01*In If IDMT 0.1 to 4.00*In step 0.01*In
This setting determines the pick-up setting for third stage measured earth fault element.			
3.	IN>3 Time Delay	1.00 S	0s to 200s step 0.01s
This setting determines the time-delay for the definite time setting if selected for third stage of measured earth fault element.			
4.	IN>3 TMS	1.000	0.025 to 1.2 step 0.005
This time multiplier setting is used to adjust the operating time of the IEC / UK IDMT characteristic.			
5.	IN>3 Time Dial	1.00	0.01 to 100 step 0.01
This time multiplier setting is used to adjust the operating time of the IEEE / US IDMT curves.			
6.	IN>3 Reset Char	DT	DT/IDMT
This setting determines the type of reset/release characteristics. IDMT applicable for IEEE / US curves only.			
7.	IN>3 RTMS	1.000	0.025 to 1.2 step 0.005
This setting determines the reset/release time for IEEE IDMT characteristic			
8.	IN>3 tRESET	0.01 S	0s to 100s step 0.01s
This setting determines the reset/release time for Definite Time (DT) and all IDMT curve			
9.	IN>3 2H Blocking	Disabled	Enabled / Disabled
This setting enables/disables blocking of third stage HV earth fault element due to presence of inrush current. If IN>3 2H Blocking and IH2 HV Prot'n settings are enabled, then (IN>3) trip command will be blocked in case 2nd harmonic content is above the IH2 HV Set and fundamental current is below I> lift 2H HV setting . (Set in SYSTEM CONFIG menu)			

2.12.5.2 LV EARTH FAULT settings

2.12.5.2.1 IN>1 Function

Sr. No	Parameter	Default setting	Setting Range
1.	LV EARTH FAULT	Derived	Derived/Measured
This setting is used to set the earth fault as derived or measured Note: Measured E/F should not be selected if LV HighZ REF protection is enabled.			

Sr. No	Parameter	Default setting	Setting Range
1.	IN>1 Function	IEC S Inverse	Disabled / DT / IEC S Inverse / S Inverse 1.3Sec / IEC V Inverse / IEC E Inverse / UK LT Inverse / IEEE M Inverse / IEEE V Inverse / IEEE E Inverse / US Inverse / US ST Inverse
This setting determines the tripping characteristic for the first stage measured earth fault element.			
2.	IN>1 Current Set	1.00*In	If DT 0.1 to 35.00*In step 0.01*In If IDMT 0.1 to 4.00*In step 0.01*In
This setting determines the pick-up setting for first stage measured earth fault element.			
3.	IN>1 Time Delay	1.00 S	0s to 200s step 0.01s
This setting determines the time-delay for the definite time setting if selected for first stage of measured earth fault element.			
4.	IN>1 TMS	1.000	0.025 to 1.2 step 0.005
This time multiplier setting is used to adjust the operating time of the IEC / UK IDMT characteristic.			
5.	IN>1 Time Dial	1.00	0.01 to 100 step 0.01
This time multiplier setting is used to adjust the operating time of the IEEE / US IDMT curves.			
6.	IN>1 Reset Char	DT	DT/IDMT
This setting determines the type of reset/release characteristics. IDMT applicable for IEEE / US curves only.			
7.	IN>1 RTMS	1.000	0.025 to 1.2 step 0.005
This setting determines the reset/release time for IEEE IDMT characteristic			
8.	IN>1 tRESET	0.01 S	0s to 100s step 0.01s
This setting determines the reset/release time for Definite Time (DT) and all IDMT curve			
9.	IN>1 2H Blocking	Disabled	Enabled / Disabled
This setting enables/disables blocking of first stage LV earth fault element due to presence of inrush current. If IN>1 2H Blocking and IH2 LV Prot'n settings are enabled, then (IN>1) trip command will be blocked in case 2nd harmonic content is above the IH2 LV Set and fundamental current is below I> lift 2H LV setting . (Set in SYSTEM CONFIG menu)			

2.12.5.2.2 IN>2 Function

Sr. No	Parameter	Default setting	Setting Range
1.	IN>2 Function	IEC S Inverse	Disabled / DT / IEC S Inverse / S Inverse 1.3Sec / IEC V Inverse / IEC E Inverse / UK LT Inverse / IEEE M Inverse / IEEE V Inverse / IEEE E Inverse / US Inverse / US ST Inverse
This setting determines the tripping characteristic for the second stage measured earth fault element.			
2.	IN>2 Current Set	1.00*In	If DT 0.1 to 35.00*In step 0.01*In If IDMT then 0.1 to 4.00*In step 0.01*In
This setting determines the pick-up setting for second stage measured earth fault element.			
3.	IN>2 Time Delay	1.00 S	0s to 200s step 0.01s
This setting determines the time-delay for the definite time setting if selected for second stage of measured earth fault element.			
4.	IN>2 TMS	1.000	0.025 to 1.2 step 0.005
This time multiplier setting is used to adjust the operating time of the IEC / UK IDMT characteristic.			
5.	IN>2 Time Dial	1.00	0.01 to 100 step 0.01
This time multiplier setting is used to adjust the operating time of the IEEE / US IDMT curves.			
6.	IN>2 Reset Char	DT	DT/IDMT
This setting determines the type of reset/release characteristics. IDMT applicable for IEEE / US curves only.			
7.	IN>2 RTMS	1.000	0.025 to 1.2 step 0.005
This setting determines the reset/release time for IEEE IDMT characteristic			

Sr. No	Parameter	Default setting	Setting Range
8.	IN>2 tRESET	0.01 S	0s to 100s step 0.01s
This setting determines the reset/release time for Definite Time (DT) and all IDMT curve			
9.	IN>2 2H Blocking	Disabled	Enabled / Disabled
This setting enables/disables blocking of second stage LV earth fault element due to presence of inrush current. If IN>2 2H Blocking and IH2 LV Prot'n settings are enabled, then (IN>2) trip command will be blocked in case 2nd harmonic content is above the IH2 LV Set and fundamental current is below I> lift 2H LV setting . (Set in SYSTEM CONFIG menu)			

2.12.5.2.3 IN>3 Function

Sr. No	Parameter	Default setting	Setting Range
1.	IN>3 Function	IEC S Inverse	Disabled / DT / IEC S Inverse / S Inverse 1.3Sec / IEC V Inverse / IEC E Inverse / UK LT Inverse / IEEE M Inverse / IEEE V Inverse / IEEE E Inverse / US Inverse / US ST Inverse
This setting determines the tripping characteristic for the third stage measured earth fault element.			
2.	IN>3 Current Set	01.00*In	If DT 1.0 to 35.00*In step 0.01*In If IDMT 0.1 to 4.00*In step 0.01*In
This setting determines the pick-up setting for third stage measured earth fault element.			
3.	IN>3 Time Delay	1.00 S	0s to 200s step 0.01s
This setting determines the time-delay for the definite time setting if selected for third stage of measured earth fault element.			
4.	IN>3 TMS	1.000	0.025 to 1.2 step 0.005
This time multiplier setting is used to adjust the operating time of the IEC / UK IDMT characteristic.			
5.	IN>3 Time Dial	1.00	0.01 to 100 step 0.01
This time multiplier setting is used to adjust the operating time of the IEEE / US IDMT curves.			
6.	IN>3 Reset Char	DT	DT/IDMT
This setting determines the type of reset/release characteristics. IDMT applicable for IEEE / US curves only.			
7.	IN>3 RTMS	1.000	0.025 to 1.2 step 0.005
This setting determines the reset/release time for IEEE IDMT characteristic			
8.	IN>3 tRESET	0.01 S	0s to 100s step 0.01s
This setting determines the reset/release time for Definite Time (DT) and all IDMT curve			
9.	IN>3 2H Blocking	Disabled	Enabled / Disabled
This setting enables/disables blocking of third stage LV earth fault element due to presence of inrush current. If IN>3 2H Blocking and IH2 LV Prot'n settings are enabled, then (IN>3) trip command will be blocked in case 2nd harmonic content is above the IH2 LV Set and fundamental current is below I> lift 2H LV setting . (Set in SYSTEM CONFIG menu)			

2.12.6 THERMAL OVERLOAD settings

Sr. No	Parameter	Default setting	Setting Range
1.	Thermal overload	HV	HV/LV
This setting is used to specify the Thermal overload function provided for HV/LV side or disabled.			
2.	Characteristic	Single	Disabled/ Single
This setting determines the operating characteristic of the thermal overload element.			
3.	Thermal Trip	1*In	0.1*In to 4.00* In step 0.01*In
This setting sets the pick-up threshold of the thermal characteristic. This would normally be the maximum full load current.			
4.	Thermal Alarm	70%	50 to 100% step 1%
This setting sets the thermal state threshold at which an alarm will be generated. This corresponds to a percentage of the trip threshold.			
5.	Time constant 1	10	1 to 200min step 1min

Sr. No	Parameter	Default setting	Setting Range
This setting determines the thermal time constant for a single time constant characteristic.			
6.	K	1.05	1 to 1.5 step 0.01
This setting specify the k constant of thermal over load function			

2.12.7 NEG SEQUENCE O/C

2.12.7.1 HV NEG SEQUENCE O/C settings

2.12.7.2 HV NEG SEQ O/C settings

2.12.7.2.1 I2>1 Function

Sr. No	Parameter	Default setting	Setting Range
1.	I2>1 Function	IEC S Inverse	Disabled / DT / IEC S Inverse / S Inverse / 1.3Sec / IEC V Inverse / IEC E Inverse / UK LT Inverse / IEEE M Inverse / IEEE V Inverse / IEEE E Inverse / US Inverse / US ST Inverse
This setting determines the tripping characteristic for the first stage Negative sequence overcurrent element.			
2.	I2>1 Current Set	1.00*In	If DT 0.10 to 35.00*In step 0.01*In If IDMT 0.10 to 4.00*In step 0.01*In
This setting determines the pick-up setting for first stage Negative sequence overcurrent element.			
3.	I2>1 Time Delay	1.00 S	0s to 200s step 0.01s
This setting determines the time-delay for the definite time setting if selected for first stage Negative sequence overcurrent element.			
4.	I2>1 TMS	1.000	0.025 to 1.2 step 0.005
This time multiplier setting is used to adjust the operating time of the IEC / UK IDMT characteristic.			
5.	I2>1 Time Dial	1.00	0.01 to 100 step 0.01
This time multiplier setting is used to adjust the operating time of the IEEE / US IDMT curves.			
6.	I2>2 Reset Char	DT	DT/IDMT
This setting determines the type of reset/release characteristics.			
7.	I2>1 RTMS	1.000	0.025 to 1.2 step 0.005
This setting determines the reset/release time for IEEE IDMT characteristic. IDMT applicable for IEEE / US curves only.			
8.	I2>1 tRESET	0.01 S	0s to 100s step 0.01s
This setting determines the reset/release time for Definite Time (DT) and all IDMT curve			
9.	I2>1 2H Blocking	Disabled	Enabled / Disabled
This setting enables/disables blocking of first stage HV negative sequence overcurrent element due to presence of inrush current. If I2>1 2H Blocking and IH2 HV Prot'n settings are enabled, then (I2>1) trip command will be blocked in case 2nd harmonic content is above the IH2 HV Set and fundamental current is below I> lift 2H HV setting. (Set in SYSTEM CONFIG menu)			

2.12.7.2.2 I2>2 Function

Sr. No	Parameter	Default setting	Setting Range
1.	I2>2 Function	IEC S Inverse	Disabled / DT / IEC S Inverse / S Inverse / 1.3Sec / IEC V Inverse / IEC E Inverse / UK LT Inverse / IEEE M Inverse / IEEE V Inverse / IEEE E Inverse / US Inverse / US ST Inverse
This setting determines the tripping characteristic for the second stage Negative sequence overcurrent element.			

Sr. No	Parameter	Default setting	Setting Range
2.	I2>2 Current Set	1.00*In	If DT 0.10 to 35.00*In step 0.01*In If IDMT 0.10 to 4.00*In step 0.01*In
This setting determines the pick-up setting for second stage Negative sequence overcurrent element.			
3.	I2>2 Time Delay	1.00 S	0s to 200s step 0.01s
This setting determines the time-delay for the definite time setting if selected for second stage Negative sequence overcurrent element.			
4.	I2>2 TMS	1.000	0.025 to 1.2 step 0.005
This time multiplier setting is used to adjust the operating time of the IEC / UK IDMT characteristic.			
5.	I2>2 Time Dial	1.00	0.01 to 100 step 0.01
This time multiplier setting is used to adjust the operating time of the IEEE / US IDMT curves.			
6.	I2>3 Reset Char	DT	DT/IDMT
This setting determines the type of reset/release characteristics. IDMT applicable for IEEE / US curves only.			
7.	I2>2 RTMS	1.000	0.025 to 1.2 step 0.005
This setting determines the reset/release time for IEEE IDMT characteristic			
8.	I2>2 tRESET	0.01 S	0s to 100s step 0.01s
This setting determines the reset/release time for Definite Time (DT) and all IDMT curve			
9.	I2>2 2H Blocking	Disabled	Enabled / Disabled
This setting enables/disables blocking of second stage HV negative sequence overcurrent element due to presence of inrush current. If I2>2 2H Blocking and IH2 HV Prof'n settings are enabled, then (I2>2) trip command will be blocked in case 2nd harmonic content is above the IH2 HV Set and fundamental current is below I> lift 2H HV setting. (Set in SYSTEM CONFIG menu)			

2.12.7.2.3 I2>3 Function

Sr. No	Parameter	Default setting	Setting Range
1.	I2>3 Function	IEC S Inverse	Disabled / DT / IEC S Inverse / S Inverse 1.3Sec / IEC V Inverse / IEC E Inverse / UK LT Inverse / IEEE M Inverse / IEEE V Inverse / IEEE E Inverse / US Inverse / US ST Inverse
This setting determines the tripping characteristic for the third stage Negative sequence overcurrent element.			
2.	I2>3 Current Set	1.00*In	If DT 1.0 to 35.00*In step 0.01*In If IDMT 0.10 to 4.00*In step 0.01*In
This setting determines the pick-up setting for second third Negative sequence overcurrent element.			
3.	I2>3 Time Delay	1.00 S	0s to 200s step 0.01s
This setting determines the time-delay for the definite time setting if selected for third stage Negative sequence overcurrent element.			
4.	I2>3 TMS	1.000	0.025 to 1.2 step 0.005
This time multiplier setting is used to adjust the operating time of the IEC / UK IDMT characteristic.			
5.	I2>3 Time Dial	1.00	0.01 to 100 step 0.01s
This time multiplier setting is used to adjust the operating time of the IEEE / US IDMT curves.			
6.	I2>3 Reset Char	DT	DT/IDMT
This setting determines the type of reset/release characteristics. IDMT applicable for IEEE / US curves only.			
7.	I2>3 RTMS	1.000	0.025 to 1.2 step 0.005
This setting determines the reset/release time for IEEE IDMT characteristic			
8.	I2>3 tRESET	0.01 S	0s to 100s step 0.01s
This setting determines the reset/release time for Definite Time (DT) and all IDMT curve			
9.	I2>3 2H Blocking	Disabled	Enabled / Disabled

Sr. No	Parameter	Default setting	Setting Range
This setting enables/disables blocking of third stage HV negative sequence overcurrent element due to presence of inrush current. If I2>3 2H Blocking and IH2 HV Prot'n settings are enabled, then (I2>3) trip command will be blocked in case 2nd harmonic content is above the IH2 HV Set and fundamental current is below I> lift 2H HV setting. (Set in SYSTEM CONFIG menu)			

2.12.7.3 LV NEG SEQ O/C settings

2.12.7.3.1 I2>1 Function

Sr. No	Parameter	Default setting	Setting Range
1.	I2>1 Function	IEC S Inverse	Disabled / DT / IEC S Inverse / S Inverse / 1.3Sec / IEC V Inverse / IEC E Inverse / UK LT Inverse / IEEE M Inverse / IEEE V Inverse / IEEE E Inverse / US Inverse / US ST Inverse
This setting determines the tripping characteristic for the first stage Negative sequence overcurrent element.			
2.	I2>1 Current Set	1.00*In	If DT 0.10 to 35.00*In step 0.01*In If IDMT 0.10 to 4.00*In step 0.01*In
This setting determines the pick-up setting for first stage Negative sequence overcurrent element.			
3.	I2>1 Time Delay	1.00 S	0s to 200s step 0.01s
This setting determines the time-delay for the definite time setting if selected for first stage Negative sequence overcurrent element.			
4.	I2>1 TMS	1.000	0.025 to 1.2 step 0.005
This time multiplier setting is used to adjust the operating time of the IEC / UK IDMT characteristic.			
5.	I2>1 Time Dial	1.00	0.01 to 100 step 0.01
This time multiplier setting is used to adjust the operating time of the IEEE / US IDMT curves.			
6.	I2>2 Reset Char	DT	DT/IDMT
This setting determines the type of reset/release characteristics.			
7.	I2>1 RTMS	1.000	0.025 to 1.2 step 0.005
This setting determines the reset/release time for IEEE IDMT characteristic. IDMT applicable for IEEE / US curves only.			
8.	I2>1 tRESET	0.01 S	0s to 100s step 0.01s
This setting determines the reset/release time for Definite Time (DT) and all IDMT curve			
9.	I2>1 2H Blocking	Disabled	Enabled / Disabled
This setting enables/disables blocking of first stage LV negative sequence overcurrent element due to presence of inrush current. If I2>1 2H Blocking and IH2 LV Prot'n settings are enabled, then (I2>1) trip command will be blocked in case 2nd harmonic content is above the IH2 LV Set and fundamental current is below I> lift 2H LV setting. (Set in SYSTEM CONFIG menu)			

2.12.7.3.2 I2>2 Function

Sr. No	Parameter	Default setting	Setting Range
1.	I2>2 Function	IEC S Inverse	Disabled / DT / IEC S Inverse / S Inverse / 1.3Sec / IEC V Inverse / IEC E Inverse / UK LT Inverse / IEEE M Inverse / IEEE V Inverse / IEEE E Inverse / US Inverse / US ST Inverse
This setting determines the tripping characteristic for the second stage Negative sequence overcurrent element.			
2.	I2>2 Current Set	1.00*In	If DT 0.10 to 35.00*In step 0.01*In If IDMT 0.10 to 4.00*In step 0.01*In
This setting determines the pick-up setting for second stage Negative sequence overcurrent element.			
3.	I2>2 Time Delay	1.00 S	0s to 200s step 0.01s
This setting determines the time-delay for the definite time setting if selected for second stage Negative sequence overcurrent element.			

Sr. No	Parameter	Default setting	Setting Range
4.	I2>2 TMS	1.000	0.025 to 1.2 step 0.005
This time multiplier setting is used to adjust the operating time of the IEC / UK IDMT characteristic.			
5.	I2>2 Time Dial	1.00	0.01 to 100 step 0.01
This time multiplier setting is used to adjust the operating time of the IEEE / US IDMT curves.			
6.	I2>3 Reset Char	DT	DT/IDMT
This setting determines the type of reset/release characteristics. IDMT applicable for IEEE / US curves only.			
7.	I2>2 RTMS	1.000	0.025 to 1.2 step 0.005
This setting determines the reset/release time for IEEE IDMT characteristic			
8.	I2>2 tRESET	0.01 S	0s to 100s step 0.01s
This setting determines the reset/release time for Definite Time (DT) and all IDMT curve			
9.	I2>2 2H Blocking	Disabled	Enabled / Disabled
This setting enables/disables blocking of second stage LV negative sequence overcurrent element due to presence of inrush current. If I2>2 2H Blocking and IH2 LV Prot'n settings are enabled, then (I2>2) trip command will be blocked in case 2nd harmonic content is above the IH2 LV Set and fundamental current is below I> lift 2H LV setting. (Set in SYSTEM CONFIG menu)			

2.12.7.3.3 I2>3 Function

Sr. No	Parameter	Default setting	Setting Range
1.	I2>3 Function	IEC S Inverse	Disabled / DT / IEC S Inverse / S Inverse / 1.3Sec / IEC V Inverse / IEC E Inverse / UK LT Inverse / IEEE M Inverse / IEEE V Inverse / IEEE E Inverse / US Inverse / US ST Inverse
This setting determines the tripping characteristic for the third stage Negative sequence overcurrent element.			
2.	I2>3 Current Set	1.00*In	If DT 1.0 to 35.00*In step 0.01*In If IDMT 0.10 to 4.00*In step 0.01*In
This setting determines the pick-up setting for second third Negative sequence overcurrent element.			
3.	I2>3 Time Delay	1.00 S	0s to 200s step 0.01s
This setting determines the time-delay for the definite time setting if selected for third stage Negative sequence overcurrent element.			
4.	I2>3 TMS	1.000	0.025 to 1.2 step 0.005
This time multiplier setting is used to adjust the operating time of the IEC / UK IDMT characteristic.			
5.	I2>3 Time Dial	1.00	0.01 to 100 step 0.01s
This time multiplier setting is used to adjust the operating time of the IEEE / US IDMT curves.			
6.	I2>3 Reset Char	DT	DT/IDMT
This setting determines the type of reset/release characteristics. IDMT applicable for IEEE / US curves only.			
7.	I2>3 RTMS	1.000	0.025 to 1.2 step 0.005
This setting determines the reset/release time for IEEE IDMT characteristic			
8.	I2>3 tRESET	0.01 S	0s to 100s step 0.01s
This setting determines the reset/release time for Definite Time (DT) and all IDMT curve			
9.	I2>3 2H Blocking	Disabled	Enabled / Disabled

Sr. No	Parameter	Default setting	Setting Range
			This setting enables/disables blocking of third stage LV negative sequence overcurrent element due to presence of inrush current. If I2>3 2H Blocking and IH2 LV Prot'n settings are enabled, then (I2>3) trip command will be blocked in case 2nd harmonic content is above the IH2 LV Set and fundamental current is below I> lift 2H LV setting. (Set in SYSTEM CONFIG menu)

2.12.8 CB FAIL settings

2.12.8.1 HV CB FAIL settings

Sr. No	Parameter	Defaults setting	Setting / Ranges
1.	CB Fail Timer	0.10 S	0s to 50s step 0.01s
			This setting sets the time delay in which the CB opening must be detected.
2.	CBF Reset	CB Open + I<	1=I< Only 2=CB Open + I< 3=Prot Reset + I< 4= CB Open
			This setting determines the elements that will reset the CB fail timer for CB Failures
3.	I<	1*In	0.05*In to 3.20*In step 0.01*In
			This setting determines the current threshold, which will reset the CB Fail timer for Overcurrent based protection
4.	Remove I> Start	Disabled	Disabled / Enabled
			This setting for removing phase overcurrent start signal following CBF operation

2.12.8.2 LV CB FAIL settings

Sr. No	Parameter	Defaults setting	Setting / Ranges
1.	CB Fail Timer	0.1 S	0s to 50s step 0.01s
			This setting sets the time delay in which the CB opening must be detected.
2.	CBF Reset	CB Open + I<	1=I< Only 2=CB Open + I< 3=Prot Reset + I< 4= CB Open
			This setting determines the elements that will reset the CB fail timer for CB Failures
3.	I<	1*In	0.05*In to 3.20*In step 0.01*In
			This setting determines the current threshold, which will reset the CB Fail timer for Overcurrent based protection
4.	Remove I> Start	Disabled	Disabled / Enabled
			This setting for removing phase overcurrent start signal following CBF operation

2.12.9 THROUGH FAULT settings

Sr. No	Parameter	Defaults setting	Setting / Ranges
1.	Through Fault	Disabled	Enabled or Disabled
			This setting enables or disables monitoring of through fault
2.	Monitored Input	HV	HV, LV or Biased Current
			This setting determines the winding to be monitored
3.	TF I> Trigger	3.85pu	0.08pu to 20pu in step 0.01pu
			A through fault event is recorded and alarm issued if any of the phase currents is larger than this setting.

2.12.10 VIEW RECORDS

Sr. No	Parameter	Display value on LCD
1.	Fault Record	Display the Records of fault i.e. parameter value, flag of fault & date and time of Fault
2.	Event Record	Display of all digital events with time stamping (max 512 events)
3.	Maint Record	Display of error generated by relay if any, in case of failure of hardware
4.	Alarm Record	Display of alarm generated by relay & date and time of generated alarm.

MONITORING & CONTROL

CHAPTER 9

1 CHAPTER OVERVIEW

This chapter consists of the following sections:

- 1 Chapter Overview**
- 2 Monitoring & Control**
 - 2.1 Monitoring Functions (Event, Fault, Disturbance record)
 - 2.1.1 Event record
 - 2.1.2 Alarm record
 - 2.1.3 Fault record
 - 2.1.4 Maintenance record
 - 2.1.5 Disturbance record
 - 2.2 Record control
 - 2.3 Display of measuring parameters
 - 2.3.1 Measurement 1 (primary values)
 - 2.3.2 Measurement 1 (secondary values)
 - 2.3.3 Measurement 2 (primary values)
 - 2.3.4 Measurement 2 (secondary values)
 - 2.3.5 Measurement 3 (primary values) **
 - 2.3.6 Measurement 3 (secondary values) **
 - 2.4 Opto inputs
 - 2.5 Output relays
 - 2.5.1 Output relay function assignment
 - 2.5.2 O/P Relay configuration
 - 2.5.3 O/P Contact Open Time
 - 2.6 Programmable LEDs
 - 2.7 Logic equations
 - 2.8 CB monitoring (HV and LV)
 - 2.8.1 CB Open Supervision (HV and LV)
 - 2.8.2 CB Open Operation Alarm (HV and LV)
 - 2.9 CB control (HV and LV)
 - 2.9.1 Local Control using IED menu (HV and LV CB)
 - 2.9.2 Remote Control
 - 2.10 Trip circuit supervision (HV and LV)
 - 2.10.1 Calculations for external resistor
 - 2.11 Self-Diagnostic features
 - 2.12 Watchdog feature

2 MONITORING & CONTROL

2.1 Monitoring Functions (Event, Fault, Disturbance record)

The IED logs three different types of record. These are Event, Fault and Disturbance records, which are stored in the IEDs non-volatile memory. It is important to log records because this allows you to establish the sequence of events that occurred, for example following a particular power system condition.

The device is capable of storing up to:

- 512 event records (including Alarm/maintenance records)
- 5 Fault records
- 5 Disturbance records

When the available space is exhausted, the oldest record is automatically overwritten by the new one. The IEDs internal clock provides a time tag for each event, to a resolution of 1 ms.

The VIEW RECORDS column contains details of these Event, Alarm, Fault and maintenance records, which can be displayed on the IEDs front panel, although it is easier to view them using the settings application software.

The device supports IEC 60870-5-103, Modbus and DNP3.0 protocol. In case IEC60870-5-103/Modbus protocol is selected while ordering, then relay auto-detects IEC-60870-5-103 and MODBUS command and responds in respective protocol. There is no specific setting which defines the protocol selection between IEC60870-5-103 and Modbus.

2.1.1 Event record

The Event record is generated when certain events happen. A change in any digital input signal or protection element output signal causes an event record to be created. These events are generated by the protection software and immediately time stamped. They are then transferred to non-volatile memory for storage.

The device continuously monitors logical and physical status. There are six physical Binary inputs provided, marked as S1, S2 up to S6. Any physical or logical change is recorded as event. These events are stored in internal, non-volatile memory along with a time stamp. Some of the events recorded include: Protection pickup, Relay Reset and CB Trip. A complete list can be found in protocol document. Up to 512 such events can be stored and downloaded for detailed analysis. Details of the event data are as follows:

Capacity: 512 events (including Alarm/maintenance records)

Time-tag: 1 millisecond

Triggers: Any selected protection alarm and threshold, Logic input change of state, Self-test events and setting changes.

The user can view the event records either using the front panel interface, the USB port or remotely using the rear EIA(RS)485 port.

2.1.2 Alarm record

The P652 logs any alarm conditions it generates as individual events. Details of the event are displayed in the **Alarm Record** submenu under **VIEW RECORDS** menu.

A Time and Date stamp is always associated with the event in question and is displayed after the event description. The alarms are stored in alarm record till the alarm is acknowledged by **CLEAR** key.

Capacity: 1 record (latest)

Triggers: Any alarm (including HV & LV circuit breaker operation alarm)

Data: Alarm description with date & time

2.1.3 Fault record

A fault record is triggered by any protection signal which trips the circuit breaker. If there are any fault records, these will appear automatically in the **VIEW RECORDS** column. You can select the fault record in the **VIEW RECORDS** column. A value of '1' corresponds to the latest fault record.

Information about the fault follows in the subsequent cells. The time stamp assigned to the fault record itself is more accurate than the corresponding stamp of the event record, because the event is logged after the actual fault record is generated. The fault measurements in the fault record are given at the time of the protection Start.

After every fault relay latched fault data which can be viewed for detailed analysis. The following details are applicable for fault record.

Capacity: 5 faults

Time-tag: 1 millisecond

Triggers: Any selected protection threshold.

Data: Fault number, type of fault (stage / phase / EF etc.), fault current magnitude in secondary, trip timing, trip counter, thermal state, fault date and time.

2.1.4 Maintenance record

Internal failures detected by the self-monitoring circuitry, such as watchdog failure and alarms related to CB operation are logged as maintenance records. If there are any maintenance records, these will appear automatically in the **VIEW RECORDS** column. You can select the maintenance record in the **Maint Record** submenu in the **VIEW RECORDS** column. The latest maintenance record is always displayed at the top while navigating the **Maint Record** submenu.

The following details are applicable for maintenance data

Capacity : 100 records

Triggers : Any hardware error and firmware incompatibility error

Data : Error code, error description and date & time

2.1.5 Disturbance record

The disturbance recorder can record the waveforms of the calibrated analogue channels, as well as the values of the digital signals. The disturbance recorder is supplied with data once per cycle, and collates the received data into a disturbance record. The disturbance records can be extracted using application software or the SCADA system, which can also store the data in COMTRADE format, allowing the use of other packages to view the recorded data.

The integral disturbance recorder has an area of memory specifically set aside for storing disturbance records. Up to 5 such waveforms can be recorded; the duration of each disturbance record is 1sec. The maximum total recording time is 5 seconds.

When the available memory is exhausted, the oldest records are overwritten by the newest ones. The disturbance recorder stores the samples that are taken at a rate of 16 samples per cycle.

Each disturbance record consists of 10 analogue data channels and 77 digital data channels. The relevant CT ratio for the analogue channels is also extracted to enable scaling to primary quantities.

The relay records the waveform of the current along with all digital and logical status during a fault. The disturbance record can be triggered from trip operation of relay. It is not possible to view the disturbance records locally via the front panel LCD. This waveform can be downloaded via the communication port for further analysis.

The fault recording is set by **Trigger Position** cell. The **Trigger Position** cell sets the trigger point as a percentage of the duration.

The details of the disturbance record are as follows:

Capacity:	5 records of 1 sec each
Pre fault Trigger position:	Programmable
Sampling rate:	16 samples/cycles
Triggers:	Trip signals, external trigger via opto input assignment.
Data:	10 analogue channels and up to 77 digital channels (physical and logical status).

2.2 Record control

The data stored in Event/Fault/Maintenance/Disturbance Records can be cleared by enabling the settings **Clear Events/Clear Faults/Clear Maint/Clear Dist Recs** in **Record Control** menu. The HV and LV CB data, Thermal State can be reset by enabling Reset HV CB Data, Reset LV CB data and Thermal Reset setting respectively.

2.3 Display of measuring parameters

The device directly measures and calculates a number of system quantities, which are updated at regular intervals. These values can be viewed in the MEASUREMENTS menu on the LCD screen using the navigation keys on the front panel or using the P50 Agile configurator tool.

The relay measurements are organised under Measurement1, Measurement2 and Measurement3 submenus for easy access of measurement information.

The device measures and displays the following quantities:

2.3.1 Measurement 1 (primary values)

Parameter	Unit	Description
IA-HV	amp	Primary current in phase A of HV winding
IB-HV	amp	Primary current in phase B of HV winding
IC-HV	amp	Primary current in phase C of HV winding
IN-HV	amp	Primary earth current in HV winding
IA-LV	amp	Primary current in phase A of LV winding
IB-LV	amp	Primary current in phase B of LV winding
IC-LV	amp	Primary current in phase C of LV winding
IN-LV	amp	Primary earth current in LV winding
I0-HV	amp	Primary zero phase sequence current in HV winding
I1-HV	amp	Primary +ve phase sequence current in HV winding
I2-HV	amp	Primary -ve phase sequence current in HV winding

Parameter	Unit	Description
I0-LV	amp	Primary zero phase sequence current in LV winding
I1-LV	amp	Primary +ve phase sequence current in LV winding
I2-LV	amp	Primary -ve phase sequence current in LV winding
IA-HV RMS	amp	Primary true RMS current in phase A of HV winding
IB-HV RMS	amp	Primary true RMS current in phase B of HV winding
IC-HV RMS	amp	Primary true RMS current in phase C of HV winding
IA-LV RMS	amp	Primary true RMS current in phase A of LV winding
IB-LV RMS	amp	Primary true RMS current in phase B of LV winding
IC-LV RMS	amp	Primary true RMS current in phase C of LV winding

2.3.2 Measurement 1 (secondary values)

Parameter	Unit	Description
ia-HV	amp	Secondary current in phase A of HV winding
ib-HV	amp	Secondary current in phase B of HV winding
ic-HV	amp	Secondary current in phase C of HV winding
in-HV	amp	Secondary earth current in HV winding
ia-LV	amp	Secondary current in phase A of LV winding
ib-LV	amp	Secondary current in phase B of LV winding
ic-LV	amp	Secondary current in phase C of LV winding
in-LV	amp	Secondary earth current in LV winding
i0-HV	amp	Secondary zero phase sequence current in HV winding
i1-HV	amp	Secondary +ve phase sequence current in HV winding
i2-HV	amp	Secondary -ve phase sequence current in HV winding
i0-LV	amp	Secondary zero phase sequence current in LV winding
i1-LV	amp	Secondary +ve phase sequence current in LV winding
i2-LV	amp	Secondary -ve phase sequence current in LV winding
ia-HV rms	amp	Secondary true RMS primary current in phase A of HV winding
ib-HV rms	amp	Secondary true RMS current in phase B of HV winding
ic-HV rms	amp	Secondary true RMS current in phase C of HV winding
ia-LV rms	amp	Secondary true RMS current in phase A of LV winding

Parameter	Unit	Description
ib-LV rms	amp	Secondary true RMS current in phase B of LV winding
ic-LV rms	amp	Secondary true RMS current in phase C of LV winding

2.3.3 Measurement 2 (primary values)

Parameter	Unit	Description
IA-BIAS	pu	Bias current on A phase winding of transformer
IA-DIFF	pu	Differential current on B phase winding of transformer
IB-BIAS	pu	Bias current on B phase winding of transformer
IB-DIFF	pu	Differential current on B phase winding of transformer
IC-BIAS	pu	Bias current on C phase winding of transformer
IC-DIFF	pu	Differential current on C phase winding of transformer
Thermal State	%	Thermal state of the Transformer
BOT-HV	millisecond	HV Breaker operating time (Breaker contact opening time for the latest trip)
BOC-HV	counter	HV Breaker operation counter (Count of total Breaker operations-local & relay tripping)
BOT-LV	millisecond	LV Breaker operating time (Breaker contact opening time for the latest trip)
BOC-LV	counter	LV Breaker operation counter (Count of total Breaker operations-local & relay tripping)
TC	counter	Breaker trip counter (Count of numbers of trip issued by relay)

2.3.4 Measurement 2 (secondary values)

Parameter	Unit	Description
ia-BIAS	pu	Bias current on A phase winding of transformer
ia-DIFF	pu	Differential current on B phase winding of transformer
ib-BIAS	pu	Bias current on B phase winding of transformer
ib-DIFF	pu	Differential current on B phase winding of transformer
ic-BIAS	pu	Bias current on C phase winding of transformer
ic-DIFF	pu	Differential current on C phase winding of transformer
Thermal State	%	Thermal state of the Transformer

Parameter	Unit	Description
BOT-HV	millisecond	HV Breaker operating time (Breaker contact opening time for the latest trip)
BOC-HV	counter	HV Breaker operation counter (Count of total Breaker operations- local & relay tripping)
BOT-LV	millisecond	LV Breaker operating time (Breaker contact opening time for the latest trip)
BOC-LV	counter	LV Breaker operation counter (Count of total Breaker operations- local & relay tripping)
TC	counter	LV Breaker trip counter (Count of numbers of trip issued by relay)

2.3.5 Measurement 3 (primary values) **

Parameter	Unit	Description
IREF HV LoZ DIFF	pu	Low impedance REF differential current on HV side
IREF HV LoZ BIAS	pu	Low impedance REF bias current on HV side
IREF LV LoZ DIFF	pu	Low impedance REF differential current on LV side
IREF LV LoZ BIAS	pu	Low impedance REF Bias current on LV side
IREF HV	pu	High impedance REF current on HV side
IREF LV	pu	High impedance REF current on LV side

2.3.6 Measurement 3 (secondary values) **

Parameter	Unit	Description
iref HV LoZ DIFF	pu	Low impedance REF differential current on HV side
iref HV LoZ BIAS	pu	Low impedance REF bias current on HV side
iref LV LoZ DIFF	pu	Low impedance REF differential current on LV side
iref LV LoZ BIAS	pu	Low impedance REF Bias current on LV side
Iref HV	pu	High impedance REF current on HV side
iref LV	pu	High impedance REF current on LV side

In the event of a fault, the type of the fault and fault current are displayed on LCD. The IED measures the fault current and stores it in the non-volatile memory.

*Note: The setting to display the measured values with respect to CT secondary or primary is available under **CONFIGURATION/Measure't Values**. Based on this setting, the representation of measurements will change in the relay.*

*** Measurement 3 values visible only when REF protection is enable.*

2.4 Opto inputs

The device supports 6 numbers of opto-inputs. The use of these opto-inputs depends on the application. There are a number of settings associated with the opto-inputs.

The relays have programmable opto-isolated logic inputs, which can be assigned to any available function which are identified as Opto I/P 1 to Opto I/P 6. These inputs are used to acquire status of external field signals such as CB close, CB open etc or can be programmed for function such as external reset, External trigger to DR etc. by using P50 Configurator as well as relay user interface. On the user interface, the Opto I/P can be assigned to any function from I/O configuration menu. The function can be assigned to any input by entering the values to them either 0 or 1 i.e. 0 = not assigned and 1 = assigned.

The following list of functions can be assigned to digital input.

Function	Description
Rem. Rst.	Function used to reset Latch type output contact and LED indication
CBFInit HV	Function used to initiate HV Breaker Fail
CBFInit LV	Function used to initiate LV Breaker Fail
Sel Grp2	Function used to enable Group 2 setting
ExTrip HV	Function initiates the relay assigned for Gen. Trip to operate and trip the HV CB.
ExTrip LV	Function initiates the relay assigned for Gen. Trip to operate and trip the LV CB.
DR Trig	Function used to trigger Disturbance Record
HV (52A)	Status used to detect HV CB Close position
HV (52B)	Status used to detect HV CB Open position
LV (52A)	Status used to detect LV CB Close position
LV (52B)	Status used to detect LV CB Open position
Blk Diff	Function used to block tripping of Differential protection
B HV I>1	Function used to block tripping of HV O/C stage 1
B HV I>2	Function used to block tripping of HV O/C stage 2
B HV I>3	Function used to block tripping of HV O/C stage 3
B LV I>1	Function used to block tripping of LV O/C stage 1
B LV I>2	Function used to block tripping of LV O/C stage 2
B LV I>3	Function used to block tripping of LV O/C stage 3
BHV I2>1	Function used to block tripping of HV NPS stage 1
BHV I2>2	Function used to block tripping of HV NPS stage 2
BHV I2>3	Function used to block tripping of HV NPS stage 3
BLV I2>1	Function used to block tripping of LV NPS stage 1
BLV I2>2	Function used to block tripping of LV NPS stage 2
BLV I2>3	Function used to block tripping of LV NPS stage 3
B HV IN>1	Function used to block tripping of HV E/F stage 1
B HV IN>2	Function used to block tripping of HV E/F stage 2
B HV IN>3	Function used to block tripping of HV E/F stage 3
B LV IN>1	Function used to block tripping of LV E/F stage 1
B LV IN>2	Function used to block tripping of LV E/F stage 2
B LV IN>3	Function used to block tripping of LV E/F stage 3
B TH OL	Function used to block tripping of Thermal Overload
HVTCSTrig	Status is used to monitor HV Trip Circuit Supervision
LVTCSTrig	Status is used to monitor LV Trip Circuit Supervision
B REF HV	Function used to block tripping of HV REF
B REF LV	Function used to block tripping of LV REF

The Digital inputs are suitable for accepting AC or DC auxiliary supply. The selection for AC or DC auxiliary supply is done from submenu **Opto I/P** under **SYSTEM DATA** menu.

The DI can be selectable for different operating voltage (ordering option) depending on the application requirement.

For details regarding the operating voltage and its threshold values, please refer to the Technical Specification section of this manual.

2.5 Output relays

The device supports 6 numbers of relay output. The use of this relay output depends on the application. There are a number of settings associated with the relay outputs.

2.5.1 Output relay function assignment

The relays have configurable logic outputs, which can be assigned to any available function. The logic outputs are identified as RL1 to RL6. All logic outputs have changeover contacts and can be configured to change state on activation of the different functions available in the relay. A basic output matrix is included in the P50 Agile configurator. Different functions can be assigned by using P50 Configurator as well as relay user interface. On the user interface, the output relays can be assigned to any function from I/O configuration menu. The function can be assigned to any input by entering the values to them either 0 or 1 i.e. 0 = not assigned and 1 = assigned.

The following diagram explains the assignment process to relay either by UI or P50 Configuration.

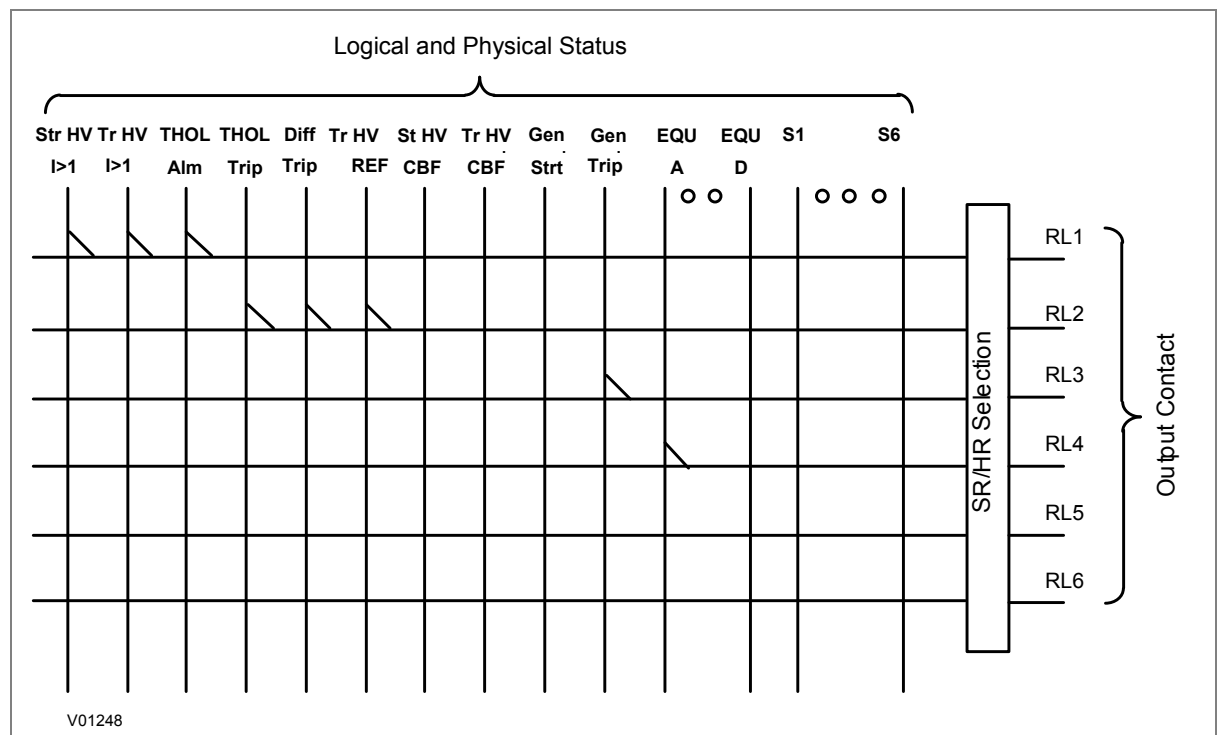

Figure 1: Output contact configuration logic

The following functions can be assigned to the relay contacts.

Function	Description
Gen Strt	General start
St Dif L1	Differential protection start detected in phase A
St Dif L2	Differential protection start detected in phase B
St Dif L3	Differential protection start detected in phase C
St HV REF	Start HV REF protection

Function	Description
St LV REF	Start LV REF protection
St HV L1	HV protection pickup in phase A
St HV L2	HV protection pickup in phase B
St HV L3	HV protection pickup in phase C
St LV L1	LV protection pickup in phase A
St LV L2	LV protection pickup in phase B
St LV L3	LV protection pickup in phase C
St HV I>1	Start HV O/C stage 1
St HV I>2	Start HV O/C stage 2
St HV I>3	Start HV O/C stage 3
St LV I>1	Start LV O/C stage 1
St LV I>2	Start LV O/C stage 2
St LV I>3	Start LV O/C stage 3
St HVI2>1	Start HV Neg seq. O/C stage 1
St HVI2>2	Start HV Neg seq. O/C stage 2
St HVI2>3	Start HV Neg seq. O/C stage 3
St LVI2>1	Start LV Neg seq. O/C stage 1
St LVI2>2	Start LV Neg seq. O/C stage 2
St LVI2>3	Start LV Neg seq. O/C stage 3
St HVIN1>1	Start HV Measured E/F stage 1
St HVIN1>2	Start HV Measured E/F stage 2
St HVIN1>3	Start HV Measured E/F stage 3
St LVIN1>1	Start LV Measured E/F stage 1
St LVIN1>2	Start LV Measured E/F stage 2
St LVIN1>3	Start LV Measured E/F stage 3
St HVIN2>1	Start HV Derived E/F stage 1
St HVIN2>2	Start HV Derived E/F stage 2
St HVIN2>3	Start HV Derived E/F stage 3
St LVIN2>1	Start LV Derived E/F stage 1
St LVIN2>2	Start LV Derived E/F stage 2
St LVIN2>3	Start LV Derived E/F stage 3
THOL Alm	Start Thermal overload alarm
St HV CBF	Start HV Breaker failure
HV I>BCBF	Block HV O/C protection during CB Fail
St LV CBF	Start LV Breaker failure
LV I>BCBF	Block LV O/C protection during CB Fail
ThroughFlt	Through fault Alarm
HV TCsAlm	HV CB Trip Circuit Supervision alarm
HVCBOprAL	HV CB Operation alarm
HVCBOpnSp	HV CB Open Supervision alarm
HVClsFail	HV CB Close Fail alarm (during control operation)
HVOpnFail	HV CB Open Fail alarm (during control operation)
LV TCsAlm	LV CB Trip Circuit Supervision alarm
LVCBOprAL	LV CB Operation alarm

Function	Description
LVCBOpnSp	LV CB Open Supervision alarm
LVCIsFail	LV CB Close Fail alarm (during control operation)
LVOpnFail	LV CB Open Fail alarm (during control operation)
Optol/P 1	Opto Input 1
Optol/P 2	Opto Input 2
Optol/P 3	Opto Input 3
Optol/P 4	Opto Input 4
Optol/P 5	Opto Input 5
Optol/P 6	Opto Input 6
Strt Diff	Differential protection start
Diff Trip	Differential protection trip
DifHS1Trp	Differential High set 1 trip
DifHS2Trp	Differential High set 2 trip
Gen Trip	General trip
Tr Dif L1	Differential Trip in phase A
Tr Dif L2	Differential Trip in phase B
Tr Dif L3	Differential Trip in phase C
Dif HS1L1	Differential High set 1 trip in phase A
Dif HS1L2	Differential High set 1 trip in phase B
Dif HS1L3	Differential High set 1 trip in phase C
Dif HS2L1	Differential High set 2 trip in phase A
Dif HS2L2	Differential High set 2 trip in phase B
Dif HS2L3	Differential High set 2 trip in phase C
Tr HV REF	HV REF trip
Tr LV REF	LV REF trip
Tr HV L1	HV Protection trip in phase A
Tr HV L2	HV Protection trip in phase B
Tr HV L3	HV Protection trip in phase C
Tr LV L1	LV Protection trip in phase A
Tr LV L2	LV Protection trip in phase B
Tr LV L3	LV Protection trip in phase C
Tr HV I>1	Trip HV O/C stage 1
Tr HV I>2	Trip HV O/C stage 2
Tr HV I>3	Trip HV O/C stage 3
Tr LV I>1	Trip LV O/C stage 1
Tr LV I>2	Trip LV O/C stage 2
Tr LV I>3	Trip LV O/C stage 3
Tr HVI2>1	Trip HV Neg seq. O/C stage 1
Tr HVI2>2	Trip HV Neg seq. O/C stage 3
Tr HVI2>3	Trip HV Neg seq. O/C stage 2
Tr LVI2>1	Trip LV Neg seq. O/C stage 1
Tr LVI2>2	Trip LV Neg seq. O/C stage 3
Tr LVI2>3	Trip LV Neg seq. O/C stage 2
TrHVIN1>1	Trip HV Measured EF stage 1

Function	Description
TrHVIN1>2	Trip HV Measured EF stage 2
TrHVIN1>3	Trip HV Measured EF stage 3
TrLVIN1>1	Trip LV Measured EF stage 1
TrLVIN1>2	Trip LV Measured EF stage 2
TrLVIN1>3	Trip LV Measured EF stage 3
TrHVIN2>1	Trip HV Derived EF stage 1
TrHVIN2>2	Trip HV Derived EF stage 2
TrHVIN2>3	Trip HV Derived EF stage 3
TrLVIN2>1	Trip LV Derived EF stage 1
TrLVIN2>2	Trip LV Derived EF stage 2
TrLVIN2>3	Trip LV Derived EF stage 3
THOL Trip	Trip Thermal overload
Tr HVCBF	Trip HV Breaker fail
Tr LVCBF	Trip LV Breaker fail
Relay OK	Relay healthy
HVCBTrip	HV Circuit Breaker Trip
HVCBClos	HV Circuit Breaker Close
LVCBTrip	LV Circuit Breaker Trip
LVCBClos	LV Circuit Breaker Close
AndLogicA	AND logic equation A
AndLogicB	AND logic equation B
AndLogicC	AND logic equation C
AndLogicD	AND logic equation D
2HBkDif	Second Harmonic blocking
2HBkDifA	Second Harmonic blocking in phase A
2HBkDifB	Second Harmonic blocking in phase B
2HBkDifC	Second Harmonic blocking in phase C
5HBkDif	Fifth Harmonic blocking
5HBkDifA	Fifth Harmonic blocking in phase A
5HBkDifB	Fifth Harmonic blocking in phase B
5HBkDifC	Fifth Harmonic blocking in phase C

Note: The above functions can be assigned to LEDs and AND Logic Equation.

2.5.2 O/P Relay configuration

All relay contacts can be individually set as self-reset or latching

The self-reset trip contact remains closed until the fault persists and opens only after fault current become less than reset value. The latching type contact will close when a fault occurs and will remain closed even if there is no fault persisting. The contact can be reset by pressing **CLEAR** key.

The selection of HR/SR type is made by changing bits value from 0 or 1 in **O/P RELAY CONFIG** menu setting.

For Self-reset output contact set bit 0

For Latch type (HR) output contact set bit 1.

The bit position for relay contacts is as shown in following table.

RL-6	RL-5	RL-4	RL-3	RL-2	RL-1	
0	0	0	0	0	0	1 is HR type & 0 is SR type

For example, if you select RL-1 to hand reset (latching) type and all other relay self-reset then you have to select the configuration below.

RL-6	RL-5	RL-4	RL-3	RL-2	RL-1	
0	0	0	0	0	1	1 is HR type & 0 is SR type

2.5.3 O/P Contact Open Time

This timer is used to hold relay contact after executing trip to ensure proper CB opening.

All digital outputs have a separate setting to set the contact open time. This timer is applicable only when output contact is SR type.

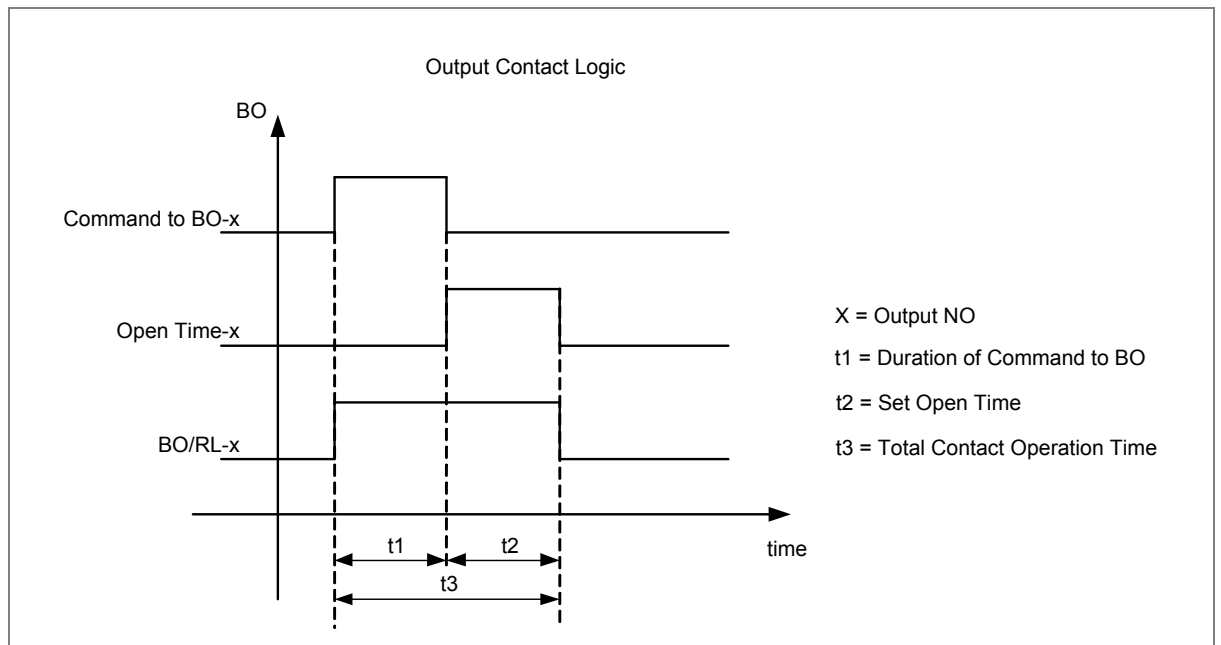

Figure 2: Output contact logic

2.6 Programmable LEDs

The device supports 4 numbers of programmable LEDs. All of the programmable LEDs on the unit are bi-colour and can be set to RED or GREEN. The use of these LEDs depends on the application. There are a number of settings associated with the relay outputs.

The programmable LEDs can be assigned to any available function. The programmable LEDs are identified as L5 to L8. Different functions can be assigned by using P50 Configurator as well as relay user interface. On the user interface, the LEDs can be assigned to any function from **I/O configuration** menu. The function can be assigned to any input by entering the values to them either 0 or 1 i.e. 0 = not assigned and 1 = assigned.

The following diagram explains the assignment process of LEDs by either by UI or P50 Configuration.

Here **G** represents **Green** LED and **R** represents **Red** LED indication. Both are part of one command dual LED.

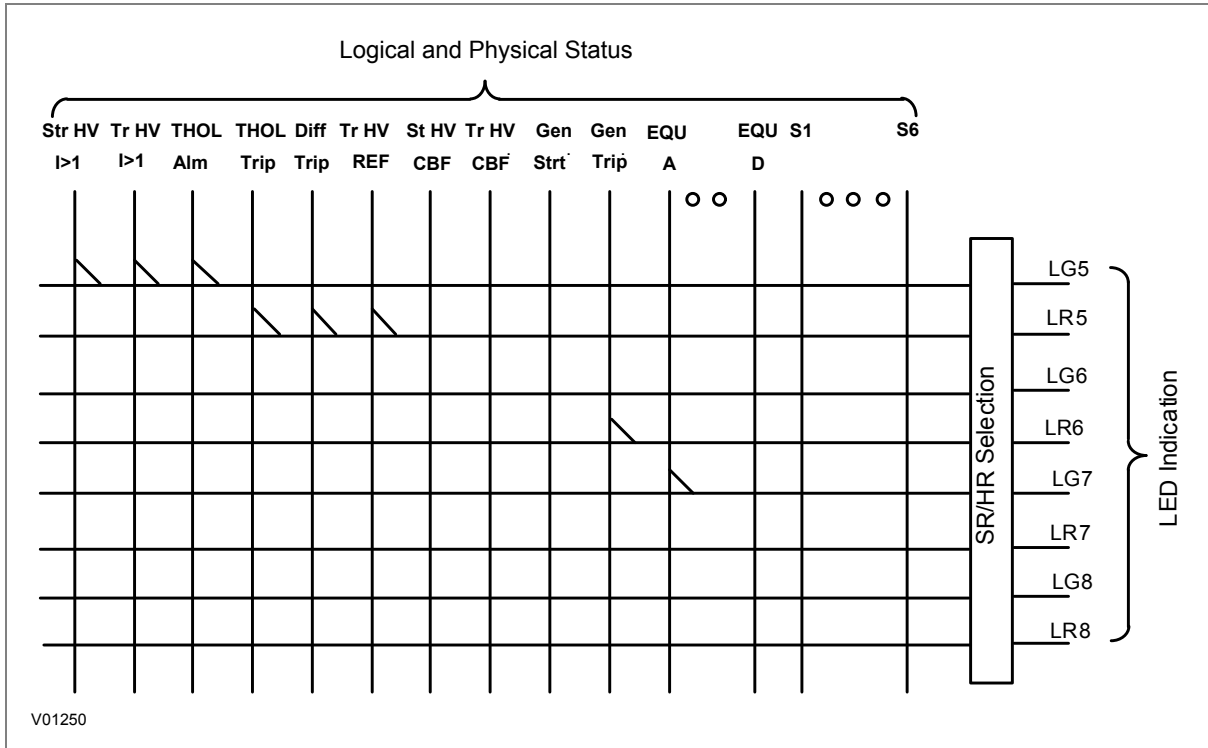

Figure 3: LEDs configuration logic

The functions that can be assigned to Green LED and Red LED are same to relay contact.

All Green LEDs and Red LEDs can be individually set as self-reset or latching

The selection of HR/SR type is made by changing bits value from 0 or 1 in **O/P Contact Configuration** setting.

For Self-reset output contact, set bit 0

For Latch type (HR) output contact, set bit 1.

The bit position for Green LEDs is as shown in following table.

LG-8	LG-7	LG-6	LG-5	
0	0	0	0	1 is HR type & 0 is SR type

The bit position for Red LEDs is as shown in following table..

LR-8	LR-7	LR-6	LR-5	
0	0	0	0	1 is HR type & 0 is SR type

2.7 Logic equations

The device supports 4 Logic AND equations which can be used to form Boolean functions using AND operators. Any function available in the IO Mask can be assigned to any single equation. Maximum numbers of the signals that can be assigned to any equation depends on the maximum number of functions available in IO mask for assignment.

The Logic equations are identified as AndLogicA, AndLogicB, AndLogicC and AndLogicD.

Any protection functions, Control Operation and opto I/Ps can be assigned to the AND logic equations and result of equation can be time delayed and assigned to any output relays and LEDs. The relevant settings are available under **O/P Relay configuration** menu.

The signals available for mapping to an equation are same as available for Relay contacts and LEDs.

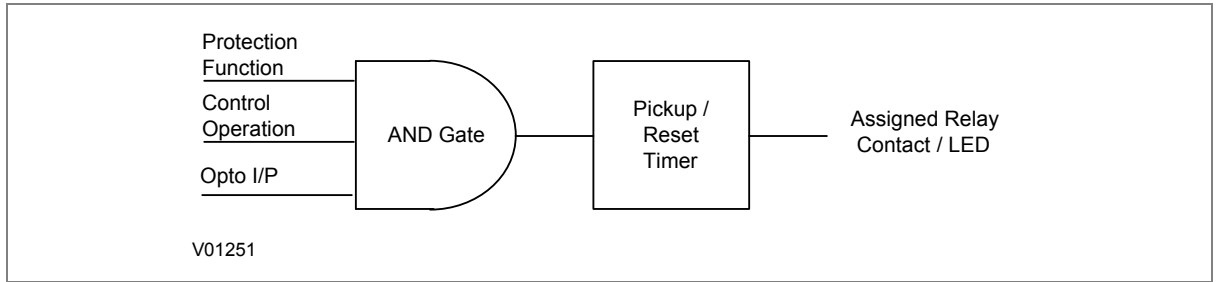

Figure 4: AND logic equation

AND Logic application example

The figure below is an example for AND logic implementation in the relay. There are two inputs to the AND equations, one is SF6 Gas low signal which is externally wired to Opto I/P 1 of relay and other input is TCS Alarm which is internally generated signal. Both signals are assigned to AND logic equation and when both the input signals are high, then the output of AND logic equation will be high. This output can be used to block all protection functions through external wiring.

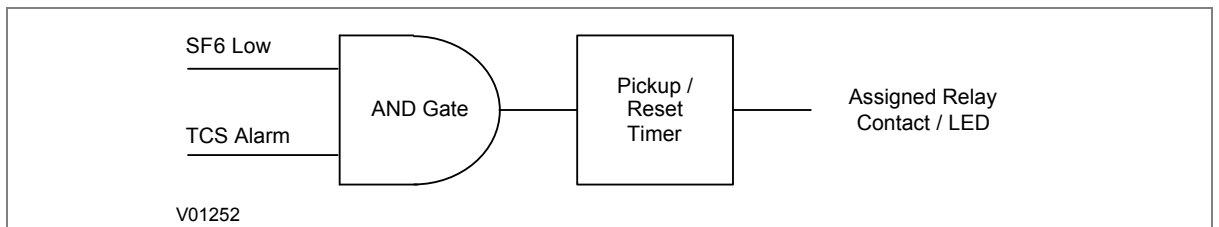

Figure 5: AND logic equation application example

2.8 CB monitoring (HV and LV)

Periodic maintenance of circuit breakers is necessary to ensure that the trip circuit and mechanism operate correctly and also that the breaking capability has not been compromised due to previous fault interruptions. Generally, such maintenance is based on a fixed time interval. These methods of monitoring circuit breaker condition give a rough guide only and can provide early indications of maintenance required. The relays record various statistics related to each circuit breaker trip operation, allowing a more accurate assessment of the circuit breaker condition.

Relay records following circuit breaker operation statistics:

Record in Measurement	Description
BOT-HV	"Breaker Opening Time"- This indicates HV circuit breaker opening time in ms.
BOC-HV	"Breaker Operation Counter"- This counter indicates number of HV circuit breaker operation.
BOT-LV	"Breaker Opening Time"- This indicates LV circuit breaker opening time in ms.
BOC-LV	"Breaker Operation Counter"- This counter indicates number of LV circuit breaker operation.
TC	"Trip Counter"- This counter indicates number of protection trip.

The above counters can be reset to zero, after maintenance inspection and overhaul.

2.8.1 CB Open Supervision (HV and LV)

Slow CB operation indicates the need for mechanism maintenance. Alarm threshold (**CB Open Time**) is provided to enforce this and can be set in the range of 50 ms to 1 s. This time relates to the interrupting time of the circuit breaker and includes relay trip contact operating time, CB main contact operation time and CB auxiliary contact operating time.

The relay starts internal timer as soon as any protection function is operated. The relay monitors the CB open contact status and stops the timer as soon as the CB open feedback is received by the relay.

If this measured time is more than setting “**CB Open Time**”, then the relay generates CB Open Supervision alarm. An alarm message is displayed on the LCD display and the START LED starts blinking. The associated event is stored in Event Record. In the event the measured Breaker opening time is less than the setting “**CB Open Time**”, the timer is reset and no alarm is generated.

Breaker opening time is displayed on the LCD display under **MEASUREMENTS** menu.

The HV CB Open Supervision logic is explained in following diagram:

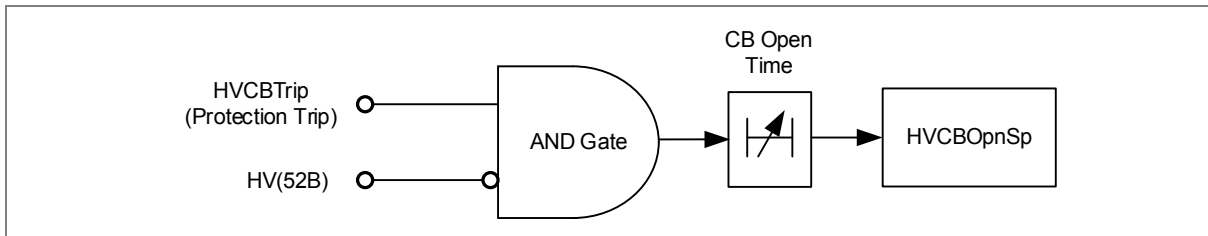

Figure 6: HV CB open supervision logic

2.8.2 CB Open Operation Alarm (HV and LV)

Every circuit breaker operation results in some degree of wear for its components. Therefore routine maintenance, such as oiling of mechanisms, may be based on the number of operations. Suitable setting of the maintenance threshold will allow an alarm to be raised, indicating when preventive maintenance is due.

Some circuit breakers, such as oil circuit breakers (OCBs) can only perform a certain number of fault interruptions before requiring maintenance attention. This is because each fault interruption causes carbonising of the oil, degrading its dielectric properties. The maintenance alarm threshold (setting CB Open operations) may be set to indicate the requirement for oil dielectric testing, or for more comprehensive maintenance.

For each circuit breaker trip operation, the relay records statistics. The relay monitors the number of circuit breaker operation by maintaining two types of counter (1) Breaker Trip counter which is based on the number of trips issued by the relay and (2) Breaker Operation counter which is the count of total breaker operations and based on the status change of CB auxiliary contact wired to one of the relay opto inputs. The relay compares the Breaker Operation Counter (**BOC**) with CB Open Operations (**CB Open Oper**) setting and generates **CB Open Operation** alarm when counter exceeds the set value, indicating that the preventative maintenance is due. The alarm message is displayed on LCD display and **START** LED starts blinking. The associated event is stored in Event Record.

2.9 CB control (HV and LV)

There are several types of circuit breaker;

- CBs with no auxiliary contacts
- CBs with 52A contacts (where the auxiliary contact follows the state of the CB)
- CBs with 52B contacts (where the auxiliary contact is in the opposite state the state of the CB)
- CBs with both 52A and 52B contacts

Circuit Breaker control is only possible if the circuit breaker in question provides auxiliary contacts.

For local control, the **CB control by** cell should be set accordingly.

The length of the trip and close control pulses can be set via the Open Pulse Time and Close Pulse Time settings respectively. These should be set long enough to ensure the breaker has completed its open or close cycle before the pulse has elapsed.

If an attempt to close the breaker is being made, and a protection trip signal is generated, the protection trip command overrides the close command.

If the CB fails to respond to the control command (indicated by no change in the state of CB Status inputs) an Open Fail alarm or Close Fail alarm is generated after the relevant trip or close pulses have expired. These alarms can be viewed on the LCD display, remotely, or can be assigned to output contacts.

The control operations of CB such as CB Open and CB Close command is controlled locally through relay HMI or Remote operation. Type of Control operation is enabled (i.e. Local, Remote or Local + Remote) in the **CB CONTROL** menu.

The device includes the following options for control of a single circuit breaker:

- Local control using the IED menu
- Remote control using remote communication

2.9.1 Local Control using IED menu (HV and LV CB)

You can control HV and LV circuit breaker manual open and close with the **CB Open/Close** cell in the **SYSTEM DATA** menu. This can be set to 'No Operation', 'Open', or 'Close' accordingly.

For this to work you have to set the **CB Control By** cell to option 2: 'Local', or option 4: 'Local+Remote' in the **CB CONTROL** menu.

2.9.2 Remote Control

Remote HV and LV CB control can be achieved by setting the **CB Open/Close** cell in the **SYSTEM DATA** column to Open or Close by using a **SCADA** command to the rear interface RP1.

For this to work, you have to set the **CB Control By** cell to option 3: 'Remote', or option 4: 'Local+Remote', in the **CB CONTROL** menu.

We recommend that you allocate separate relay output contacts for remote CB control and protection tripping. This allows you to select the control outputs using a simple local/remote selector switch as shown below. Where this feature is not required the same output contact(s) can be used for both protection and remote tripping.

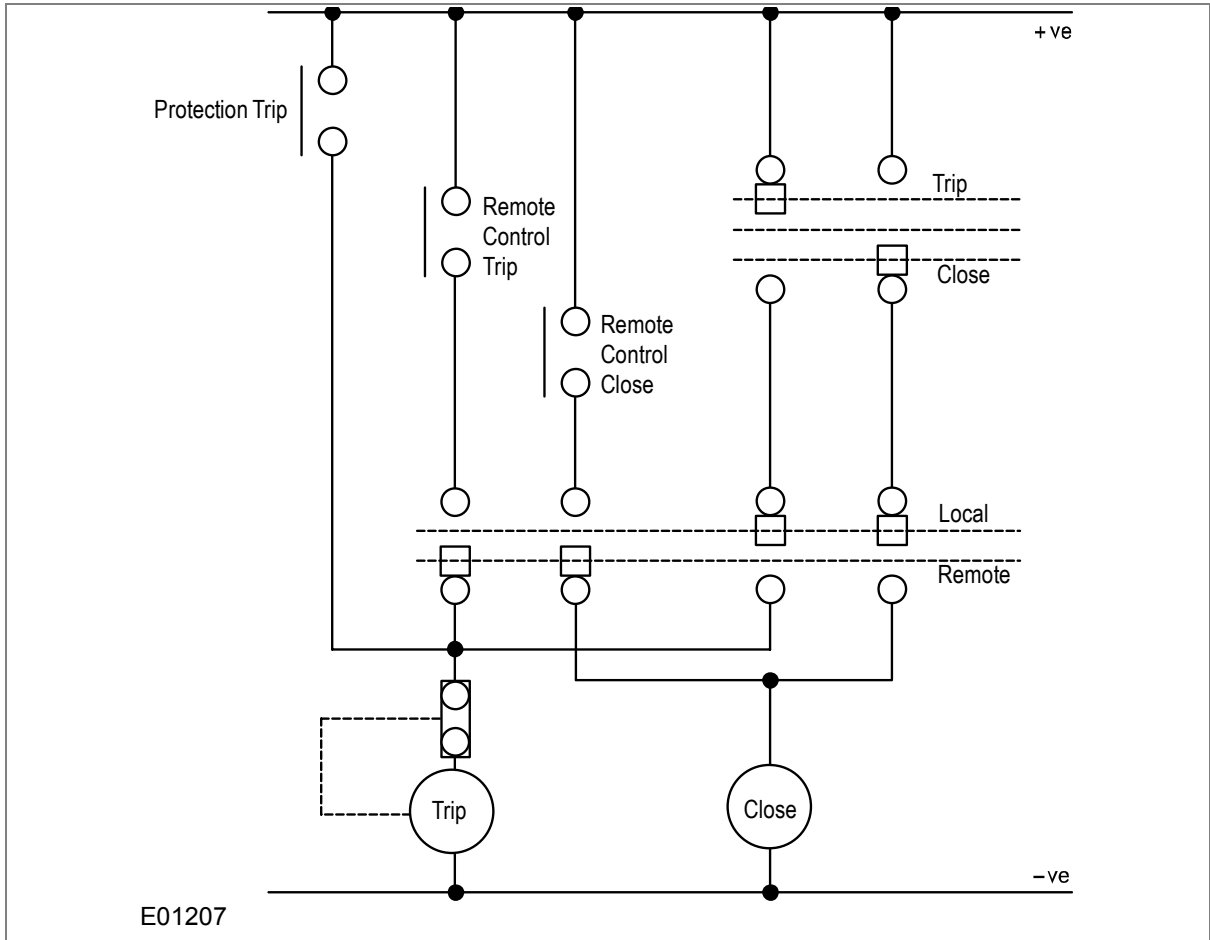

Figure 7: Local and Remote Control of Circuit Breaker

For CB OPEN command:

Once a CB Open command is received from local or remote the assigned relay contact for the CB trip will operate. Simultaneously the relay starts monitoring the status of opto input 52B. If the status of 52B input is not high after the expiry of open pulse time (settable in the range of 0.1 to 50 sec), then the relay output contact, which is assigned to CB Open fail, will operate. Simultaneously the relay will generate an Open Fail alarm on the LCD display and the associated event will be stored in the Event Record.

The HVCB open fail logic is explained in following diagram:

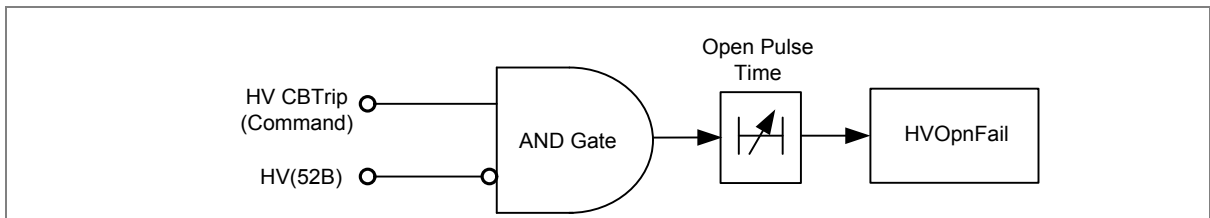

Figure 8: HV CB open fail alarm

For CB CLOSE command:

Once a CB Close command is received from local or remote the assigned relay contact for the CB close will operate. Simultaneously the relay starts monitoring the status of opto input 52A. If the status of 52A input is not high after the expiry of close pulse time (settable in the range of 0.1 to 50 sec), then the relay output contact, which is assigned to CB Close fail, will operate. Simultaneously the relay will generate Close Fail alarm on the LCD display and the associated event will be stored in the Event Record.

The HV CB close fail logic is explained in following diagram:

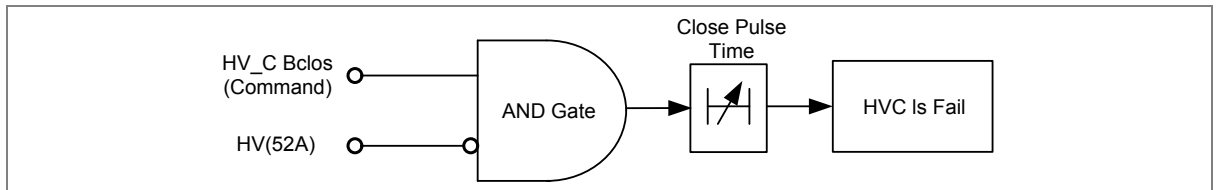

Figure 9: HV CB close fail alarm

2.10 Trip circuit supervision (HV and LV)

TCS scheme provides supervision of the trip coil with the breaker open or closed but does not provide pre-closing supervision of the trip path. However, using two opto-inputs allows the IED to correctly monitor the Trip Circuit. This can be done by assigning **TCS Trig** signal to the opto inputs, which are connected to Circuit Breaker auxiliary contacts (52A and 52B).

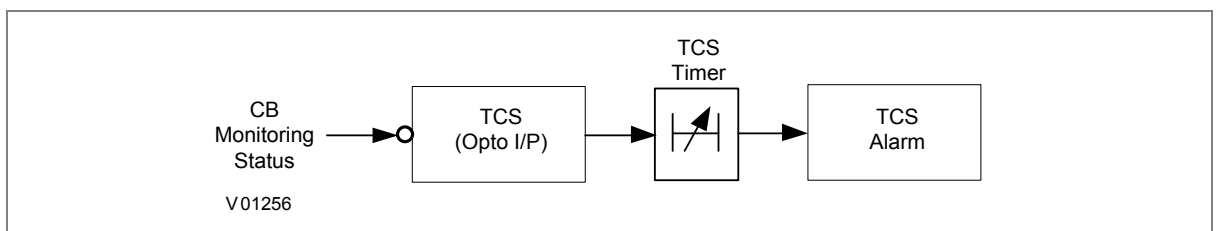

Figure 10: Trip circuit supervision logic

The TCS scheme is also fully compatible with latched contacts as the supervision current will be maintained through the 52B contact when the trip contact is closed.

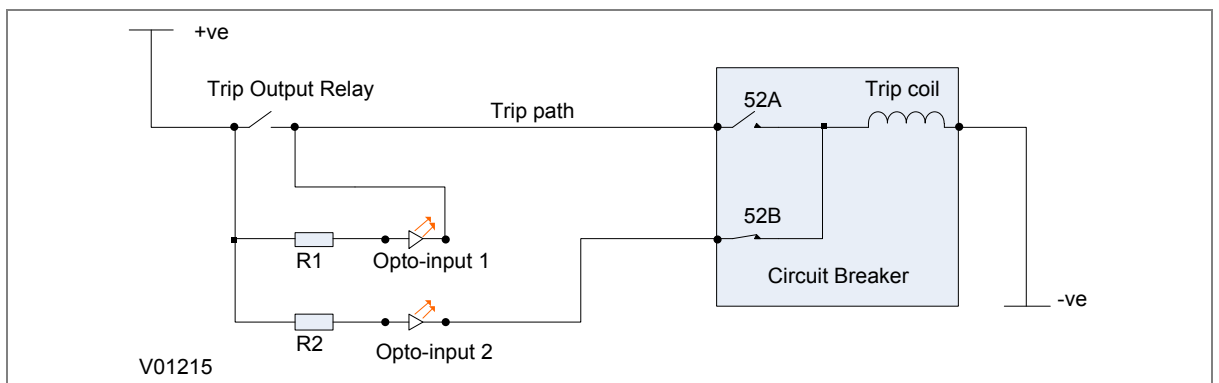

Figure 11: TCS scheme

When the breaker is closed, supervision current passes through opto input 1 and the trip coil. When the breaker is open current flows through opto input 2 and the trip coil. No supervision of the trip path is provided whilst the breaker is open. Any fault in the trip path will only be detected on CB closing, after the elapse of TCS timer available under **CB CONTROL** menu.

2.10.1 Calculations for external resistor

As shown in the TCS scheme, optional resistors R1 and R2 can be added to prevent tripping of the CB if either opto input is shorted.

The minimum sensing current required by opto coupler is 0.18 mA and the maximum current capacity of opto coupler is 10 mA. For the safe operation, the current should be always between minimum required current and maximum current capacity of opto coupler. The maximum current is limited by internal resistor (RInt.) connected in series with opto coupler. The value of this internal resistor (RInt.) is 82 KΩ (Ohm).

The supervision current is a lot less than the current required by the trip coil to trip a CB. The opto-input limits this supervision current. If the opto-input were to be short-circuited however; it could be possible for the supervision current to reach a level that could trip the CB. For this reason, optional resistors R1 and R2 are often used to limit the current in the event of a short-circuited opto-input. It is recommended to use 2.5 K Ω / 50 W resistor for all type of auxiliary power supply.

2.11 Self-Diagnostic features

The P652 relay includes self-monitoring function to check the operation of its hardware and software while in service. If there is a problem with the hardware or software, it is able to detect and report the problem.

The relay continuously monitors the hardware and in the event detects any hardware fault/error; corresponding error code is displayed on the LCD. These faults / errors are stored in the '**Main't Rec Num**' and can be viewed from **Maint Record** submenu. Error log is stored as 16 bit integer.

For example if an RTC error occurs then the error code/error log will be as follows:

Error code : 0000 0000 0000 0100

Error log on LCD: 0004

If the error is cleared during the self-diagnostic procedure the corresponding error bit will be cleared. The P652 internal errors are also indicated by a change in status of **ON** and **OUT OF SERVICE** LEDs. For more details, refer to the 'Maintenance and Troubleshooting' chapter.

2.12 Watchdog feature

The relay continuously monitors the healthiness of hardware and detects the hardware fault/error. As soon as an internal fault is detected, the **ON** LED changes from green to red and the contact assigned to '**Relay OK**' signal operates.

The output contact assigned to '**Relay OK**' signal remains in active state when the relay is Healthy, i.e. NO contact will be in closed position and vice versa.

The output contact assigned to '**Relay OK**' will become inactive in case any error is detected or failure of auxiliary supply.

There are 6 nos. of programmable binary outputs (changeover type contacts) marked as RL1 to RL6. Any binary output can be assigned as watchdog contact by assigning '**Relay OK**' signal through '**IO CONFIGURATION**' setting or using '**IO Mask**' function in P50 Agile Configurator.

SCADA COMMUNICATIONS

CHAPTER 10

1 CHAPTER OVERVIEW

This chapter consists of the following sections:

- 1 Chapter Overview**
- 2 SCADA Communications**
 - 2.1 Modbus
 - 2.1.1 Overview
 - 2.1.1.1 Physical connection and link layer
 - 2.1.2 MODBUS functions
 - 2.1.2.1 Protocol mapping
 - 2.2 IEC60-870-5-103
 - 2.2.1 Overview
 - 2.2.2 Physical connection and link layer
 - 2.2.3 Initialisation
 - 2.2.4 Time synchronisation
 - 2.2.5 Spontaneous events
 - 2.2.6 General interrogation (GI)
 - 2.2.7 Cyclic measurements
 - 2.2.8 Commands
 - 2.2.9 Test mode
 - 2.2.10 Disturbance records
 - 2.2.11 Configuration
 - 2.2.12 Protocol mapping
 - 2.3 DNP3.0
 - 2.3.1 Overview
 - 2.3.2 DNP V3.00 device Profile
 - 2.3.3 Implementation Table
 - 2.3.4 Point List
 - 2.3.4.1 Binary Input Points
 - 2.3.4.2 Binary Output Status Points and Control Output Blocks
 - 2.3.4.3 Binary Counters
 - 2.3.4.4 Analog Inputs

2 SCADA COMMUNICATIONS

2.1 Modbus

This section describes how the MODBUS standard is applied to the Px50 platform. It is not a description of the standard itself. The level at which this section is written assumes that the reader is already familiar with the MODBUS standard.

The MODBUS protocol is a master/slave protocol, defined and administered by the MODBUS Organization. For further information on MODBUS and the protocol specifications please see the Modbus web site (www.modbus.org).

2.1.1 Overview

2.1.1.1 Physical connection and link layer

Only one option is available for connecting MODBUS.

- Rear serial port 1 - for permanent SCADA connection via EIA(RS)485

The MODBUS interface uses 'RTU' mode communication rather than 'ASCII' mode as this provides more efficient use of the communication bandwidth. This mode of communication is defined by the MODBUS standard.

The IED address and baud rate can be selected using the front panel menu or with P50 Agile configurator.

When using a serial interface, the data format is: 1 start bit, 8 data bits, 1 stop bit and 1 parity bit (a total of 11 bits per character).

2.1.2 MODBUS functions

2.1.2.1 Protocol mapping

The following MODBUS function codes are supported:

Code	Function Name	Addresses starts with
02	Read Input Status	1x addresses
03	Read Holding Registers	4x addresses
04	Read Input Registers	3x addresses
05	Force Single Coil	0x addresses
16	Preset Multiple Registers	4x addresses

- Exception Codes generated in case of an error:

Code	MODBUS Response Name	Product interpretation
01	Illegal Function Code	The function code received in query is not supported by the IED.
02	Illegal Data Address	The start address received in the query is not an allowable value.

Note: If the start address received is correct but the range includes unsupported address, then this error is produced.

Note: The addresses of the MODBUS registers start from 1 and the user may have to subtract 1 from the addresses, depending upon the Master station configuration.

Sr. No.		Function Code	Register	No. of Regs	Format	Reg. Type	Address Map
1	Product Information	03					
			Manufacturer Name	10	20-Bytes ASCII	R	40001 – 40010
			Relay Name	10	20-Bytes ASCII	R	40011 – 40020
			Model	10	20-Bytes ASCII	R	40021 – 40030
			Version	10	20-Bytes ASCII	R	40031 – 40040
			Relay Description	10	20-Bytes ASCII	R	40041 – 40050

Sr. No.		Function Code	Register	No. of Regs	Format	Reg. Type	Address Map
2	Relay Configuration	03					
			Num Status (s)	1	16 bit	R	40258
			Num Controls (c)	1	16 bit	R	40259
			Num Parameters (p)	1	16 bit	R	40260
			Num Faults (f)	1	16 bit	R	40261

Sr. No.		Function Code	Register	No. of Regs	Format	Reg. Type	Address Map
3	Time Synchronization (Unicast/Broadcast)	03/16					
			Year	1	16 bit	R/W	42049
			Month- Day	1	16 bit	R/W	42050
			Hour, Min	1	16 bit	R/W	42051
			Milliseconds	1	16 bit	R/W	42052

For GE Vernova P50 Agile relays on Modbus, time synchronization is possible via a broadcast command to 800H (42049 through 42052). The format is inverted IEC 870-5-4 CP56Time2a																	
Words	7	6	5	4	3	2	1	0	7	6	5	4	3	2	1	0	
1	0	0	0	0	0	0	0	0	Year								00..99
2	0	0	0	0	Month				Day of Week			Day of Month			1..12 1..7 1..31		
3	SU 0 0			Hours				lv 0			Minutes			0..23 0..59			
4	Milliseconds Hi								Milliseconds Lo								0..59999 (seconds + milliseconds)

Su	(=0 Standard, =1 Summer Time)						
iv	(=0 valid, =1 non valid or non synchronised system case)						
	First Day of week is Monday						
Sr. No.	Function Code	Register	No. of Regs	Format	Reg. Type	Address Map	
4	Status and Logical Status	02					
		Gen Strt	1	1 bit	R	12769	
		St HV L1	1	1 bit	R	12770	
		St HV L2	1	1 bit	R	12771	
		St HV L3	1	1 bit	R	12772	
		St HV I>1	1	1 bit	R	12773	
		St HV I>2	1	1 bit	R	12774	
		St HV I>3	1	1 bit	R	12775	
		St HVI2>1	1	1 bit	R	12776	
		St HVI2>2	1	1 bit	R	12777	
		St HVI2>3	1	1 bit	R	12778	
		StHVIN1>1	1	1 bit	R	12779	
		StHVIN1>2	1	1 bit	R	12780	
		StHVIN1>3	1	1 bit	R	12781	
		StHVIN2>1	1	1 bit	R	12782	
		StHVIN2>2	1	1 bit	R	12783	
		StHVIN2>3	1	1 bit	R	12784	
		THOL Alm	1	1 bit	R	12786	
		St HV CBF	1	1 bit	R	12789	
		HV I>BCBF	1	1 bit	R	12790	
		Test Mode	1	1 bit	R	12792	
		HVCIsFail	1	1 bit	R	12793	
		HVOpnFail	1	1 bit	R	12794	
		Relay OK	1	1 bit	R	12795	
		Gen Trip	1	1 bit	R	12796	
		Tr HV L1	1	1 bit	R	12797	
		Tr HV L2	1	1 bit	R	12798	
		Tr HV L3	1	1 bit	R	12799	
		Tr HV I>1	1	1 bit	R	12800	
		Tr HV I>2	1	1 bit	R	12801	
		Tr HV I>3	1	1 bit	R	12802	
		Tr HVI2>1	1	1 bit	R	12803	
		Tr HVI2>2	1	1 bit	R	12804	
		Tr HVI2>3	1	1 bit	R	12805	
		TrHVIN1>1	1	1 bit	R	12806	
		TrHVIN1>2	1	1 bit	R	12807	
		TrHVIN1>3	1	1 bit	R	12808	
		TrHVIN2>1	1	1 bit	R	12809	
		TrHVIN2>2	1	1 bit	R	12810	
		TrHVIN2>3	1	1 bit	R	12811	

Sr. No.	Function Code	Register	No. of Regs	Format	Reg. Type	Address Map
		THOL Trip	1	1 bit	R	12813
		Tr HVCBF	1	1 bit	R	12816
		HV Ext Trip	1	1 bit	R	12817
		HVCBOprAL	1	1 bit	R	12818
		Optol/P 1	1	1 bit	R	12819
		Optol/P 2	1	1 bit	R	12820
		Optol/P 3	1	1 bit	R	12821
		Optol/P 4	1	1 bit	R	12822
		Optol/P 5	1	1 bit	R	12823
		Optol/P 6	1	1 bit	R	12824
		HV TCSAlm	1	1 bit	R	12825
		Trip LED	1	1 bit	R	12826
		HVCBOpnSp	1	1 bit	R	12827
		St LV L1	1	1 bit	R	15101
		St LV L2	1	1 bit	R	15102
		St LV L3	1	1 bit	R	15103
		St LV I>1	1	1 bit	R	15104
		St LV I>2	1	1 bit	R	15105
		St LV I>3	1	1 bit	R	15106
		St LVI2>1	1	1 bit	R	15107
		St LVI2>2	1	1 bit	R	15108
		St LVI2>3	1	1 bit	R	15109
		StLVIN1>1	1	1 bit	R	15110
		StLVIN1>2	1	1 bit	R	15111
		StLVIN1>3	1	1 bit	R	15112
		StLVIN2>1	1	1 bit	R	15113
		StLVIN2>2	1	1 bit	R	15114
		StLVIN2>3	1	1 bit	R	15115
		St LV CBF	1	1 bit	R	15116
		LV I>BCBF	1	1 bit	R	15117
		LVClsFail	1	1 bit	R	15118
		LVOpnFail	1	1 bit	R	15119

Sr. No.	Function Code	Register	No. of Regs	Format	Reg. Type	Address Map
		Tr LV L1	1	1 bit	R	15120
		Tr LV L2	1	1 bit	R	15121
		Tr LV L3	1	1 bit	R	15122
		Tr LV I>1	1	1 bit	R	15123
		Tr LV I>2	1	1 bit	R	15124
		Tr LV I>3	1	1 bit	R	15125
		Tr LVI2>1	1	1 bit	R	15126
		Tr LVI2>2	1	1 bit	R	15127
		Tr LVI2>3	1	1 bit	R	15128
		TrLVIN1>1	1	1 bit	R	15129
		TrLVIN1>2	1	1 bit	R	15130
		TrLVIN1>3	1	1 bit	R	15131
		TrLVIN2>1	1	1 bit	R	15132
		TrLVIN2>2	1	1 bit	R	15133
		TrLVIN2>3	1	1 bit	R	15134
		Tr LV CBF	1	1 bit	R	15135
		LV Ext Trip	1	1 bit	R	15136
		LVCBOPrAL	1	1 bit	R	15137
		LV TCSAlm	1	1 bit	R	15138
		LVCBOPnSp	1	1 bit	R	15139
		St Dif L1	1	1 bit	R	15140
		St Dif L2	1	1 bit	R	15141
		St Dif L3	1	1 bit	R	15142
		St HV Ref	1	1 bit	R	15143
		St LV Ref	1	1 bit	R	15144
		Tr Dif L1	1	1 bit	R	15145
		Tr Dif L2	1	1 bit	R	15146
		Tr Dif L3	1	1 bit	R	15147
		Dif HS1L1	1	1 bit	R	15148
		Dif HS1L2	1	1 bit	R	15149
		Dif HS1L3	1	1 bit	R	15150
		Dif HS2L1	1	1 bit	R	15151

Sr. No.		Function Code	Register	No. of Regs	Format	Reg. Type	Address Map
			Dif HS2L2	1	1 bit	R	15152
			Dif HS2L3	1	1 bit	R	15153
			Tr HV REF	1	1 bit	R	15154
			Tr LV REF	1	1 bit	R	15155
			ThrougFlt	1	1 bit	R	15156
			Strt Diff	1	1 bit	R	15157
			Diff Trip	1	1 bit	R	15158
			DifHS1Trp	1	1 bit	R	15159
			DifHS2Trp	1	1 bit	R	15160

Sr.No.		Function Code	Register	No. of Regs	Format	Reg. Type	Address Map
5	Outputs	05					
			LED Reset	1	16 bit	W	03025
			HV CB Trip	1	16 bit	W	03026
			HV CB Close	1	16 bit	W	03027
			Output 1	1	16 bit	W	03028
			Output 2	1	16 bit	W	03029
			Output 3	1	16 bit	W	03030
			Output 4	1	16 bit	W	03031
			Output 5	1	16 bit	W	03032
			Output 6	1	16 bit	W	03033
			LV CB Trip	1	16 bit	W	03034
			LV CB Close	1	16 bit	W	03035

Sr.No.		Function Code	Register	No. of Regs	Format	Reg. Type	Address Map
6	Parameters	04					
			IL1 HV	2	32 bit Float	R	33281– 33282
			IL2 HV	2	32 bit Float	R	33283– 33284
			IL3 HV	2	32 bit Float	R	33285 – 33286
			IN HV	2	32 bit Float	R	33287 – 33288
			I2 HV	2	32 bit Float	R	33291 – 33292
			I1 HV	2	32 bit Float	R	33293 – 33294
			Thermal State	2	32 bit Float	R	33295 – 33296
			L1-RMS HV	2	32 bit Float	R	33299 – 33300
			L2-RMS HV	2	32 bit Float	R	33301– 33302
			L3-RMS HV	2	32 bit Float	R	33303– 33304
			TC	2	32 bit Float	R	33305– 33306
			BOC HV	2	32 bit Float	R	33307– 33308
			BOT HV	2	32 bit Float	R	33309– 33310
			I0 HV	2	32 bit Float	R	33311– 33312
			IBIAS L1	2	32 bit Float	R	35301– 35302
			IDIFF L1	2	32 bit Float	R	35303– 35304
			IBIAS L2	2	32 bit Float	R	35305– 35306
			IDIFF L2	2	32 bit Float	R	35307– 35308
			IBIAS L3	2	32 bit Float	R	35309– 35310
			IDIFF L3	2	32 bit Float	R	35311– 35312
			IREF HV	2	32 bit Float	R	35313– 35314
			IREF LV	2	32 bit Float	R	35315– 35316
			IREF LoZ BIAS HV	2	32 bit Float	R	35317– 35318
			IREF LoZ DIFF HV	2	32 bit Float	R	35319– 35320
			IL1 LV	2	32 bit Float	R	35321– 35322
			IL2 LV	2	32 bit Float	R	35323– 35324
			IL3 LV	2	32 bit Float	R	35325– 35326
			IN LV	2	32 bit Float	R	35327– 35328
			I0 LV	2	32 bit Float	R	35329– 35330
			I1 LV	2	32 bit Float	R	35331– 35332
			I2 LV	2	32 bit Float	R	35333– 35334
			L1-RMS LV	2	32 bit Float	R	35335– 35336
			L2-RMS LV	2	32 bit Float	R	35337– 35338
			L3-RMS LV	2	32 bit Float	R	35339– 35340
			BOT LV	2	32 bit Float	R	35341– 35342
			BOC LV	2	32 bit Float	R	35343– 35344
			IREF LoZ BIAS LV	2	32 bit Float	R	35345– 35346
			IREF LoZ DIFF LV	2	32 bit Float	R	35347– 35348

2.2 IEC60-870-5-103

2.2.1 Overview

The specification IEC 60870-5-103 (Telecontrol Equipment and Systems Part 5 Section 103: Transmission Protocols), defines the use of standards IEC 60870-5-1 to IEC 60870-5-5, which were designed for communication with protection equipment.

This section describes how the IEC 60870-5-103 standard is applied to the P652 relay. It is not a description of the standard itself. The level at which this section is written assumes that the reader is already familiar with the IEC 60870-5-103 standard.

This section should provide sufficient detail to enable understanding of the standard at a level required by most users.

The IEC 60870-5-103 interface is a master/slave interface with the device as the slave device. The device conforms to compatibility level 2, as defined in the IEC 60870-5-103 standard.

The following IEC 60870-5-103 facilities are supported by this interface:

- Initialization (reset)
- Time synchronisation
- Event record extraction
- General interrogation
- Cyclic measurements
- General commands
- Disturbance record extraction

2.2.2 Physical connection and link layer

There is just one option for IEC 60870-5-103:

- Rear serial port 1- for permanent SCADA connection via RS485

The IED address and baud rate can be selected using the front panel menu or with P50 Agile configurator.

2.2.3 Initialisation

Whenever the device has been powered up, or if the communication parameters have been changed, a reset command is required to initialize the communications. The device will respond to either of the two reset commands; Reset CU or Reset FCB (Communication Unit or Frame Count Bit). The difference between the two commands is that the Reset CU command will clear any unsent messages in the transmit buffer, whereas the Reset FCB command does not delete any messages.

The device will respond to the reset command with an identification message ASDU 5. The Cause of Transmission (COT) of this response will be either Reset CU or Reset FCB depending on the nature of the reset command.

The relay will also produce a power up event, when the relay is powered up.

2.2.4 Time synchronisation

The time and date can be set using the time synchronisation feature of the IEC 60870-5-103 protocol. The device will correct the transmission delay depending on communication speed. For this, transmission time, required for the time synchronization frame from the Master to IED, considering current baud rate is added in the received time.

The device will correct the transmission delay depending on baud rate. If the time synchronisation message is sent as a send/confirm message then the device will respond with a confirm message. A time synchronisation Class 1 event will be generated/produced whether the time-synchronisation message is sent as a send confirm or a broadcast (send/no reply) message.

2.2.5 Spontaneous events

Events are categorized using the following information:

- Function type
- Information Number

The IEC 60870-5-103 profile contains a complete listing of all events produced by the device.

2.2.6 General interrogation (GI)

The GI request can be used to read the status of the device, the function numbers, and information numbers that will be returned during the GI cycle. These are shown in the IEC 60870-5-103 profile.

2.2.7 Cyclic measurements

The device will produce measured values using ASDU 3 or ASDU 9 & ASDU 244. ASDU 3 will be reported with information number 147, ASDU9 is reported with information number 148 and ASDU 244 is reported with information number 0. These three frames are reported alternately. This can be read from the device using a Class 2 poll. For every query the current online data is reported.

The device transmits its measurands at 2.4 times the rated value of the analogue value.

2.2.8 Commands

The list of commands supported in P652 relay is provided in section 2.2.12 -Protocol Mapping (Sr.No.8). The device will respond to valid Control Command with ASDU1 and a cause of transmission indicating 'Positive (COT-20) / Negative (COT-21) acknowledgement'. The device will respond to commands with invalid FUN/ INF combination with an ASDU 1, with a cause of transmission indicating 'negative acknowledgement'.

2.2.9 Test mode

It is possible to enable test mode in the relay using either the front panel menu or with P50 Agile configurator. An event will be produced to indicate both entry to and exit from test mode. Spontaneous events and cyclic measured data transmitted whilst the device is in test mode will have a COT of 'test mode'.

2.2.10 Disturbance records

The disturbance records are stored in uncompressed format and can be extracted using the standard mechanisms described in IEC 60870-5-103. This relay supports up-to 5 records.

2.2.11 Configuration

To configure the IED for this protocol, please see the Configuration chapter.

2.2.12 Protocol mapping

Sr. No.	INF	Description	GI	TYP	COT	FUN
1	Semantics of INFORMATION NUMBER : System Functions in monitor direction					
	0	End of general interrogation	-	8	10	255
	0	Time synchronization	-	6	8	255
	2	Reset FCB	-	5	3	160
	3	Reset CU	-	5	4	160
	4	Start/Restart	-	5	5	160
	5	Power on	-	5	6	160

Note: X under GI heading means DI Status is included in General Interrogation response.

Sr. No.	INF	Description	GI	TYP	COT	FUN
2	Semantics of INFORMATION NUMBER : Status Indications in monitor direction					
	19	Trip LED	X	1	1,7,9,11,12,20,21	160
	22	Local parameter setting	X	1	11,12	160
	27	Opto I/P-1	X	1	1,7,9	160
	28	Opto I/P-2	X	1	1,7,9	160
	29	Opto I/P-3	X	1	1,7,9	160
	30	Opto I/P-4	X	1	1,7,9	160
	31	Opto I/P-5	X	1	1,7,9	127
	32	Opto I/P-6	X	1	1,7,9	127
	36	HV TCS Alarm	X	1	1,7,9	160
	203	LV TCS Alarm	X	1	1,7,9	124
	134	Password Reset	-	2	1,7	124
	135	HV CBOpr Alm	X	2	1,7,9	124
	204	LV CBOpr Alm	X	2	1,7,9	124

Sr. No.	INF	Description	GI	TYP	COT	FUN
3	Semantics of INFORMATION NUMBER : Fault indications in monitor direction					
	84	Gen Strt	X	2	1,7,9	160
	182	St Dif L1	X	2	1,7,9	124
	183	St Dif L2	X	2	1,7,9	124
	184	St Dif L3	X	2	1,7,9	124
	172	St HV Ref	X	2	1,7,9	124
	173	St LV Ref	X	2	1,7,9	124
	64	St HV L1	X	2	1,7,9	126
	65	St HV L2	X	2	1,7,9	126
	66	St HV L3	X	2	1,7,9	126
	185	St LV L1	X	2	1,7,9	124
	186	St LV L2	X	2	1,7,9	124
	187	St LV L3	X	2	1,7,9	124
	117	St HV I>1	X	2	1,7,9	126
	103	St HV I>2	X	2	1,7,9	126
	105	St HV I>3	X	2	1,7,9	126
	188	St LV I>1	X	2	1,7,9	124
	189	St LV I>2	X	2	1,7,9	124
	190	St LV I>3	X	2	1,7,9	124
	126	St HVI2>1	X	2	1,7,9	126
	146	St HVI2>2	X	2	1,7,9	126
	147	St HVI2>3	X	2	1,7,9	126
	191	St LVI2>1	X	2	1,7,9	124
	192	St LVI2>2	X	2	1,7,9	124
	193	St LVI2>3	X	2	1,7,9	124
	143	StHVIN1>1	X	2	1,7,9	126
	144	StHVIN1>2	X	2	1,7,9	126
	145	StHVIN1>3	X	2	1,7,9	126
	194	StLVIN1>1	X	2	1,7,9	124
	195	StLVIN1>2	X	2	1,7,9	124
	196	StLVIN1>3	X	2	1,7,9	124
	140	StHVIN2>1	X	2	1,7,9	126
	141	StHVIN2>2	X	2	1,7,9	126
	142	StHVIN2>3	X	2	1,7,9	126
	197	StLVIN2>1	X	2	1,7,9	124
	198	StLVIN2>2	X	2	1,7,9	124
	199	StLVIN2>3	X	2	1,7,9	124
	200	THOL Alm	-	2	1,7,9	126
	26	St HV CBF	X	2	1,7,9	124
	154	HV I>BCBF	-	2	1,7,9	124
	200	St LV CBF	X	2	1,7,9	124
	201	LV I>BCBF	-	2	1,7,9	124
	202	ThrougFit	-	2	1,7,9	124

Sr. No.	INF	Description	GI	TYP	COT	FUN
	1	HVCBOpnSp	-	2	1,7,9	124
	205	LVCBOpnSp	-	2	1,7,9	124
	156	HVClsFail	-	2	1,7,9	124
	157	HVOpnFail	-	2	1,7,9	124
	209	LVClsFail	-	2	1,7,9	124
	210	LVOpnFail	-	2	1,7,9	124
	68	Gen Trip	-	2	1,7	160
	94	Tr Dif L1	-	2	1,7	126
	95	Tr Dif L2	-	2	1,7	126
	96	Tr Dif L3	-	2	1,7	126
	167	Dif HS1L1	-	2	1,7	124
	168	Dif HS1L2	-	2	1,7	124
	169	Dif HS1L3	-	2	1,7	124
	222	Dif HS2L1	-	2	1,7	124
	223	Dif HS2L2	-	2	1,7	124
	224	Dif HS2L3	-	2	1,7	124
	170	Tr HV REF	-	2	1,7	124
	171	Tr LV REF	-	2	1,7	124
	69	Tr HV L1	-	2	1,7	160
	70	Tr HV L2	-	2	1,7	160
	71	Tr HV L3	-	2	1,7	160
	174	Tr LV L1	-	2	1,7	124
	175	Tr LV L2	-	2	1,7	124
	176	Tr LV L3	-	2	1,7	124
	90	Tr HV I>1	-	2	1,7	160
	91	Tr HV I>2	-	2	1,7	160
	104	Tr HV I>3	-	2	1,7	126
	214	Tr LV I>1	-	2	1,7	126
	215	Tr LV I>2	-	2	1,7	126
	216	Tr LV I>3	-	2	1,7	126
	158	Tr HVI2>1	-	2	1,7	124
	127	Tr HVI2>2	-	2	1,7	126
	128	Tr HVI2>3	-	2	1,7	126
	177	Tr LVI2>1	-	2	1,7	124
	220	Tr LVI2>2	-	2	1,7	124
	221	Tr LVI2>3	-	2	1,7	124
	123	TrHVIN1>1	-	2	1,7	126
	124	TrHVIN1>2	-	2	1,7	126
	125	TrHVIN1>3	-	2	1,7	126
	178	TrLVIN1>1	-	2	1,7	124
	179	TrLVIN1>2	-	2	1,7	124
	180	TrLVIN1>3	-	2	1,7	124
	92	TrHVIN2>1	-	2	1,7	160
	93	TrHVIN2>2	-	2	1,7	160

Sr. No.	INF	Description	GI	TYP	COT	FUN
	121	TrHVIN2>3	-	2	1,7	126
	217	TrLVIN2>1	-	2	1,7	126
	218	TrLVIN2>2	-	2	1,7	126
	219	TrLVIN2>3	-	2	1,7	126
	202	THOL Trip	-	2	1,7	126
	85	Tr HVCBF	-	2	1,7	126
	181	Tr LVCBF	-	2	1,7	124
	145	Relay OK	-	2	1,7	127
	22	Test Mode	-	2	1,7	124
	2	HV Ext Trip	-	2	1,7	124
	208	LV Ext Trip	-	2	1,7	124
	211	Strt Diff	-	2	1,7,9	124
	212	Diff Trip	-	2	1,7	124
	213	DifHS1Trp	-	2	1,7	124
	214	DifHS2Trp	-	2	1,7	124

Sr. No.	INF	Description	GI	TYP	COT	FUN
4	Semantics of INFORMATION NUMBER : Measurands in monitor direction					
	148	Measurand I _{L 1,2,3}	-	9	2,7	160
	147	Measurand I _{N (HV)}	-	3	2,7	160
	0	IA-HV,IB-HV,IC-HV,IN-HV, IA-LV,IB-LV,IC-LV,IN-LV, I0-HV,I1-HV,I2-HV, I0-LV,I1-LV,I2-LV, IA-HV RMS,IB-HV RMS, IC-HV RMS, IA-LV RMS,IB-LV RMS, IC-LV RMS, IA-BIAS,IA-DIFF,IB-BIAS,IB- DIFF,IC-BIAS,IC-DIFF, Thermal State, TC, BOT-HV,BOC-HV, BOT-LV,BOC-LV, IREF HV LoZ BIAS, IREF HV LoZ DIFF, IREF LV LoZ BIAS, IREF LV LoZ DIFF, IREF HV,IREF LV,	-	244	2,7	127

Sr. No.	INF	Description	GI	TYP	COT	FUN
5	Semantics of INFORMATION NUMBER: Fault list in monitor direction					
	0	List of Recorded DR	-	23	31	160

Sr. No.	INF	Description
6	Semantics of Actual Channel : Used for DR Transmission	
	ACC	Description
	1	IA-HV
	2	IB-HV
	3	IC-HV
	4	IN-HV
	64	IA-LV
	65	IB-LV
	66	IC-LV
	90	IN-LV
	74	IREF HV
	127	IREF LV

Sr. No.	INF	Description	GI	TYP	COT	FUN
7	Semantics of INFORMATION NUMBER : System Functions in control direction					
	0	Initialization of general interrogation	-	7	9	255
	0	Time synchronization	-	6	8	255

Sr. No.	INF	Description	GI	TYP	COT	FUN
8	Semantics of INFORMATION NUMBER : General commands in control direction					
	19	LED Reset	ON	20	20	160
	123	HV CB Trip	ON/OFF	20	20	127
	125	HV CB Close	ON/OFF	20	20	127
	206	LV CB Trip	ON/OFF	20	20	124
	207	LV CB Close	ON/OFF	20	20	124
	94	Output 1	ON/OFF	20	20	127
	95	Output 2	ON/OFF	20	20	127
	96	Output 3	ON/OFF	20	20	127
	97	Output 4	ON/OFF	20	20	127
	98	Output 5	ON/OFF	20	20	127
	99	Output 6	ON/OFF	20	20	127

2.3 DNP3.0

2.3.1 Overview

This section describes the specific implementation of the Distributed Network Protocol (DNP 3.0) in P652 – Transformer protection relay.

It uses Triangle MicroWorks, Inc. DNP 3.0 Slave Source Code Library Version 3.17.

This document is to be referred in conjunction with the DNP3.0 Basic 4 Document Set, and the DNP Subset Definitions Document, for complete information on how to communicate with P652 using DNP3.0 protocol.

This implementation of DNP3.0 is fully compliant with DNP3.0 Subset Definition Level 2 and contains many Subset Level 3 features including some functionality beyond Subset Level 3.

2.3.2 DNP V3.00 device Profile

The following table provides a “Device Profile Document” in the standard format defined in the DNP 3.0 Subset Definition Document. While it is referred to in the DNP 3.0 Subset Definition as a “Document”, it is only a component of a total interoperability guide. This table, in combination with the following should provide a complete interoperability/configuration guide for P652.

This table in combination with the following should provide a complete interoperability/configuration guide for the P652 relays:

- The Implementation Table provided in Section 2.3.3
- The Point List Tables provided in Section 2.3.4

<h1 style="margin: 0;">DNP V3.00</h1> <h2 style="margin: 0;">DEVICE PROFILE DOCUMENT</h2>	
Vendor Name: GE Vernova	
Device Name: P50 Platform using the Triangle MicroWorks, Inc. DNP 3.0 Slave Source Code Library, Version 3.17.	
Highest DNP Level Supported: For Requests: Level 2 For Responses: Level 2	Device Function: <input checked="" type="checkbox"/> Master <input type="checkbox"/> Slave

Notable objects, functions, and/or qualifiers supported in addition to the Highest DNP Levels supported (the complete list is described in the attached table):

For static (non-change-event) object requests, request qualifier codes 00 and 01 (start-stop), 07 and 08 (limited quantity), and 17 and 28 (index) are supported in addition to request qualifier code 06 (no range – or all points).

Static object requests received with qualifiers 00, 01, 06, 07, or 08, will be responded with qualifiers 00 or 01. Static object requests received with qualifiers 17 or 28 will be responded with qualifiers 17 or 28.

For change-event object requests, qualifiers 17 or 28 are always responded.

16-bit and 32-bit Analog Change Events with Time may be requested.

The read function code for Object 50 (Time and Date), variation 1, is supported.

<p>Maximum Data Link Frame Size (octets):</p> <p>Transmitted: 292 Received: 292</p>	<p>Maximum Application Fragment Size (octets):</p> <p>Transmitted: 2048 Received: 2048</p>
<p>Maximum Data Link Re-tries:</p> <p><input checked="" type="checkbox"/> None <input type="checkbox"/> Fixed at 2 <input checked="" type="checkbox"/> Configurable</p>	<p>Maximum Application Layer Re-tries:</p> <p><input type="checkbox"/> None <input checked="" type="checkbox"/> Configurable</p>
<p>Requires Data Link Layer Confirmation:</p> <p><input type="checkbox"/> Never <input checked="" type="checkbox"/> Always <input checked="" type="checkbox"/> Sometimes <input checked="" type="checkbox"/> Configurable</p>	
<p>Requires Application Layer Confirmation:</p> <p><input checked="" type="checkbox"/> Never <input checked="" type="checkbox"/> Always (not recommended) <input type="checkbox"/> When reporting Event Data (Slave devices only) <input type="checkbox"/> When sending multi-fragment responses (Slave devices only) <input checked="" type="checkbox"/> Sometimes <input checked="" type="checkbox"/> Configurable</p>	

Timeouts while waiting for:				
Data Link Confirm:	<input checked="" type="checkbox"/> None	<input type="checkbox"/> Fixed at 100ms	<input checked="" type="checkbox"/> Variable	<input checked="" type="checkbox"/> Configurable
Complete Appl. Fragment:	<input type="checkbox"/> None	<input checked="" type="checkbox"/> Fixed at _____	<input checked="" type="checkbox"/> Variable	<input checked="" type="checkbox"/> Configurable
Application Confirm:	<input checked="" type="checkbox"/> None	<input type="checkbox"/> Fixed at 1s	<input checked="" type="checkbox"/> Variable	<input checked="" type="checkbox"/> Configurable
Complete Appl. Response:	<input type="checkbox"/> None	<input checked="" type="checkbox"/> Fixed at _____	<input checked="" type="checkbox"/> Variable	<input checked="" type="checkbox"/> Configurable
Others:				
Binary Input change scanning period:	2ms			
Analog Input change scanning period:	1s			
Sends/Executes Control Operations:				
WRITE Binary Outputs	<input type="checkbox"/> Never	<input checked="" type="checkbox"/> Always	<input checked="" type="checkbox"/> Sometimes	<input checked="" type="checkbox"/> Configurable
SELECT/OPERATE	<input checked="" type="checkbox"/> Never	<input type="checkbox"/> Always	<input checked="" type="checkbox"/> Sometimes	<input checked="" type="checkbox"/> Configurable
DIRECT OPERATE	<input checked="" type="checkbox"/> Never	<input type="checkbox"/> Always	<input checked="" type="checkbox"/> Sometimes	<input checked="" type="checkbox"/> Configurable
DIRECT OPERATE - NO ACK	<input checked="" type="checkbox"/> Never	<input type="checkbox"/> Always	<input checked="" type="checkbox"/> Sometimes	<input checked="" type="checkbox"/> Configurable
Count > 1	<input type="checkbox"/> Never	<input checked="" type="checkbox"/> Always	<input checked="" type="checkbox"/> Sometimes	<input checked="" type="checkbox"/> Configurable
Pulse On	<input checked="" type="checkbox"/> Never	<input type="checkbox"/> Always	<input checked="" type="checkbox"/> Sometimes	<input checked="" type="checkbox"/> Configurable
Pulse Off	<input type="checkbox"/> Never	<input checked="" type="checkbox"/> Always	<input checked="" type="checkbox"/> Sometimes	<input checked="" type="checkbox"/> Configurable
Latch On	<input type="checkbox"/> Never	<input checked="" type="checkbox"/> Always	<input checked="" type="checkbox"/> Sometimes	<input checked="" type="checkbox"/> Configurable
Latch Off	<input type="checkbox"/> Never	<input checked="" type="checkbox"/> Always	<input checked="" type="checkbox"/> Sometimes	<input checked="" type="checkbox"/> Configurable
Queue	<input type="checkbox"/> Never	<input checked="" type="checkbox"/> Always	<input checked="" type="checkbox"/> Sometimes	<input checked="" type="checkbox"/> Configurable
Clear Queue	<input type="checkbox"/> Never	<input checked="" type="checkbox"/> Always	<input checked="" type="checkbox"/> Sometimes	<input checked="" type="checkbox"/> Configurable
Reports Binary Input Change Events when no specific variation requested: <input checked="" type="checkbox"/> Never <input type="checkbox"/> Only time-tagged <input checked="" type="checkbox"/> Only non-time-tagged <input checked="" type="checkbox"/> Configurable	Reports time-tagged Binary Input Change Events when no specific variation requested: <input checked="" type="checkbox"/> Never <input type="checkbox"/> Binary Input Change With Time <input checked="" type="checkbox"/> Binary Input Change With Relative Time <input checked="" type="checkbox"/> Configurable (attach explanation)			

<p>Sends Unsolicited Responses:</p> <ul style="list-style-type: none"> <input checked="" type="checkbox"/> Never <input checked="" type="checkbox"/> Configurable (attach explanation) <input checked="" type="checkbox"/> Only certain objects <input checked="" type="checkbox"/> Sometimes (attach explanation) <input type="checkbox"/> ENABLE/DISABLE UNSOLICITED Function codes supported 	<p>Sends Static Data in Unsolicited Responses:</p> <ul style="list-style-type: none"> <input type="checkbox"/> Never <input checked="" type="checkbox"/> When Device Restarts <input checked="" type="checkbox"/> When Status Flags Change <p>No other options are permitted.</p>												
<p>Default Counter Object/Variation:</p> <ul style="list-style-type: none"> <input checked="" type="checkbox"/> No Counters Reported <input checked="" type="checkbox"/> Configurable (attach explanation) <input type="checkbox"/> Default Object: 20 <input type="checkbox"/> Default Variation: 5 <input checked="" type="checkbox"/> Point-by-point list attached 	<p>Counters Roll Over at:</p> <table border="1" data-bbox="699 819 1501 999"> <thead> <tr> <th>Point Index</th> <th>Name/Description</th> <th>Roll Over value</th> </tr> </thead> <tbody> <tr> <td>0</td> <td>TC</td> <td>9999</td> </tr> <tr> <td>1</td> <td>HV BOC</td> <td>Settable up to 30000</td> </tr> <tr> <td>2</td> <td>LV BOC</td> <td>Settable up to 30000</td> </tr> </tbody> </table> <ul style="list-style-type: none"> <input checked="" type="checkbox"/> No Counters Reported <input checked="" type="checkbox"/> Configurable (attach explanation) <input checked="" type="checkbox"/> 16 Bits <input type="checkbox"/> 32 Bits <input checked="" type="checkbox"/> Other Value <input checked="" type="checkbox"/> Point-by-point list attached 	Point Index	Name/Description	Roll Over value	0	TC	9999	1	HV BOC	Settable up to 30000	2	LV BOC	Settable up to 30000
Point Index	Name/Description	Roll Over value											
0	TC	9999											
1	HV BOC	Settable up to 30000											
2	LV BOC	Settable up to 30000											

2.3.3 Implementation Table

The following table identifies the variations, function codes, and qualifiers supported by the P652 in both request messages and in response messages.

For static (non-change-event) objects, requests sent with qualifiers 00, 01, 06, 07, or 08, will be responded with qualifiers 00 or 01. Static object requests sent with qualifiers 17 or 28 will be responded with qualifiers 17 or 28. For change-event objects, qualifiers 17 or 28 are always responded.

In the table below, the text shaded as indicates Subset Level 3 functionality (beyond Subset Level 2) and text shaded as indicates functionality beyond Subset Level 3.

OBJECT			REQUEST (Library will parse)		RESPONSE (Library will respond with)	
Object Number	Variation Number	Description	Function Codes (dec)	Qualifier Codes (hex)	Function Codes (dec)	Qualifier Codes (hex)
1	0	Binary Input (Variation 0 is used to request default variation)	1 (read)	00, 01 (start-stop) 06 (no range, or all) 07, 08 (limited qty) 17, 28 (index)		
1	1 (default – see note 1)	Binary Input	1 (read) 22	00, 01 (start-stop) 06 (no range, or all) 07, 08 (limited qty) 17, 28 (index)	129 (response)	00, 01 (start-stop) 17, 28 (index – see note 2)
1	2	Binary Input with Status	1 (read)	00, 01 (start-stop) 06 (no range, or all) 07, 08 (limited qty) 17, 28 (index)	129 (response)	00, 01 (start-stop) 17, 28 (index – see note 2)
2	0	Binary Input Change (Variation 0 is used to request default variation)	1 (read)	06 (no range, or all) 07, 08 (limited qty)		
2	1	Binary Input Change without Time	1 (read)	06 (no range, or all) 07, 08 (limited qty)	129 (response)	17, 28 (index)
2	2 (default – see note 1)	Binary Input Change with Time	1 (read)	06 (no range, or all) 07, 08 (limited qty)	129 (response)	17, 28 (index)
10	0	Binary Output Status (Variation 0 is used to request default variation)	1 (read)	00, 01 (start-stop) 06 (no range, or all) 07, 08 (limited qty) 17, 28 (index)		
10	2 (default – see note 1)	Binary Output Status	1 (read)	00, 01 (start-stop) 06 (no range, or all) 07, 08 (limited qty) 17, 28 (index)	129 (response)	00, 01 (start-stop) 17, 28 (index – see note 2)
12	1 (default – see note 1)	Control Relay Output Block	3 (select) 4 (operate) 5 (direct op) 6 (dir.op,noack)	00, 01 (start-stop) 07, 08 (limited qty) 17, 28 (index)	129 (response)	Echo of request

OBJECT			REQUEST (Library will parse)		RESPONSE (Library will respond with)	
Object Number	Variation Number	Description	Function Codes (dec)	Qualifier Codes (hex)	Function Codes (dec)	Qualifier Codes (hex)
20	0	Binary Counter (Variation 0 is used to request default variation)	1 (read) 7 (freeze) 8 (freezenoack) 9 (freeze clear) 10 (frz. cl. Noack)	00, 01 (start-stop) 06 (no range, or all) 07, 08 (limited qty) 17, 28 (index)		
20	1	32-Bit Binary Counter	1 (read) 7 (freeze) 8 (freeze noack) 9 (freeze clear) 10 (frz. cl. Noack)	00, 01 (start-stop) 06 (no range, or all) 07, 08 (limited qty) 17, 28 (index)	129 (response)	00, 01 (start-stop) 17, 28 (index – see note 2)
20	2	16-Bit Binary Counter	1 (read) 7 (freeze) 8 (freeze noack) 9 (freeze clear) 10 (frz. cl. Noack)	00, 01 (start-stop) 06 (no range, or all) 07, 08 (limited qty) 17, 28 (index)	129 (response)	00, 01 (start-stop) 17, 28 (index – see note 2)
20	5 (default – see note 1)	32-Bit Binary Counter without Flag	1 (read) 7 (freeze) 8 (freeze noack) 9 (freeze clear) 10 (frz. cl. Noack)	00, 01 (start-stop) 06 (no range, or all) 07, 08 (limited qty) 17, 28 (index)	129 (response)	00, 01 (start-stop) 17, 28 (index – see note 2)
20	6	16-Bit Binary Counter without Flag	1 (read) 7 (freeze) 8 (freeze noack) 9 (freeze clear) 10 (frz. cl. Noack)	00, 01 (start-stop) 06 (no range, or all) 07, 08 (limited qty) 17, 28 (index)	129 (response)	00, 01 (start-stop) 17, 28 (index – see note 2)
22	0	Counter change Event	1 (read)	06 (no range, or all) 07, 08 (limited qty)		
22	1 (default – see note 1)	32-Bit Counter Change Event without Time	1 (read)	06 (no range, or all) 07, 08 (limited qty)	129 (response)	17, 28 (index – see note 2)
22	2	16-Bit Counter Change Event without Time	1 (read)	06 (no range, or all) 07, 08 (limited qty)	129 (response)	17, 28 (index – see note 2)
22	5	32-Bit Counter Change Event with Time	1 (read)	06 (no range, or all) 07, 08 (limited qty)	129 (response)	17, 28 (index – see note 2)
22	6	16-Bit Counter Change Event with Time	1 (read)	06 (no range, or all) 07, 08 (limited qty)	129 (response)	17, 28 (index – see note 2)
30	0	Analog Input (Variation 0 is used to request default variation)	1 (read)	00, 01 (start-stop) 06 (no range, or all) 07, 08 (limited qty) 17, 28 (index)		
30	1	32-Bit Analog Input	1 (read)	00, 01 (start-stop) 06 (no range, or all) 07, 08 (limited qty) 17, 28 (index)	129 (response)	00, 01 (start-stop) 17, 28 (index – see note 2)
30	2	16-Bit Analog Input	1 (read)	00, 01 (start-stop) 06 (no range, or all) 07, 08 (limited qty) 17, 28 (index)	129 (response)	00, 01 (start-stop) 17, 28 (index – see note 2)
30	3 (default – see note 1)	32-Bit Analog Input without Flag	1 (read)	00, 01 (start-stop) 06 (no range, or all) 07, 08 (limited qty) 17, 28 (index)	129 (response)	00, 01 (start-stop) 17, 28 (index – see note 2)
30	4	16-Bit Analog Input without Flag	1 (read)	00, 01 (start-stop) 06 (no range, or all) 07, 08 (limited qty) 17, 28 (index)	129 (response)	00, 01 (start-stop) 17, 28 (index – see note 2)

OBJECT			REQUEST (Library will parse)		RESPONSE (Library will respond with)	
Object Number	Variation Number	Description	Function Codes (dec)	Qualifier Codes (hex)	Function Codes (dec)	Qualifier Codes (hex)
30	5	Single-precision, floating-point with flag	1 (read)	00, 01 (start-stop) 06 (no range, or all) 07, 08 (limited qty) 17, 28 (index)	129 (response)	00, 01 (start-stop) 17, 28 (index – see note 2)
32	0	Analog Change Event (Variation 0 is used to request default variation)	1 (read)	06 (no range, or all) 07, 08 (limited qty)		
32	1 (default – see note 1)	32-Bit Analog Change Event without Time	1 (read)	06 (no range, or all) 07, 08 (limited qty)	129 (response)	17, 28 (index)
32	2	16-Bit Analog Change Event without Time	1 (read)	06 (no range, or all) 07, 08 (limited qty)	129 (response)	17, 28 (index)
32	3	32-Bit Analog Change Event with Time	1 (read)	06 (no range, or all) 07, 08 (limited qty)	129 (response)	17, 28 (index)
32	4	16-Bit Analog Change Event with Time	1 (read)	06 (no range, or all) 07, 08 (limited qty)	129 (response)	17, 28 (index)
32	7	Single-precision, floating-point with time	1 (read)	06 (no range, or all) 07, 08 (limited qty)	129 (response)	17, 28 (index)
50	0	Time and Date	1 (read)	00, 01 (start-stop) 06 (no range, or all) 07, 08 (limited qty) 17, 28 (index)	129 (response)	00, 01 (start-stop) 17, 28 (index – see note 2)
50	1 (default – see note 1)	Time and Date	1 (read) 2 (write)	00, 01 (start-stop) 06 (no range, or all) 07 (limited qty=1) 08 (limited qty) 17, 28 (index)	129 (response)	00, 01 (start-stop) 17, 28 (index – see note 2)
60	0	Class 0, 1, 2, and 3 Data	1 (read)	06 (no range, or all)		
60	1	Class 0 Data	1 (read)	06 (no range, or all)	129 (response)	17,28
60	2	Class 1 Data	1 (read)	06 (no range, or all) 07, 08 (limited qty)	129 (response)	17,28
60	3	Class 2 Data	1 (read)	06 (no range, or all) 07, 08 (limited qty)	129 (response)	17,28
60	4	Class 3 Data	1 (read)	06 (no range, or all) 07, 08 (limited qty)	129 (response)	17,28
80	1	Internal Indications	2 (write)	00 (start-stop) (index must =7)	129 (response)	17,28
		No Object (function code only)	13 (cold restart)			
		No Object (function code only)	14 (warm restart)			
		No Object (function code only)	23 (delay meas.)			

Note 1: A Default variation refers to the variation responded when variation 0 is requested and/or in class 0, 1, 2, or 3 scans.

Note 2: For static (non-change-event) objects, qualifiers 17 or 28 are only responded when a request is sent with qualifiers 17 or 28, respectively. Otherwise, static object requests sent with qualifiers 00, 01, 06, 07, or 08, will be responded with qualifiers 00 or 01. (For change-event objects, qualifiers 17 or 28 are always responded.)

2.3.4 Point List

The tables in the following sections identify all the individual data points provided by this implementation of DNP 3.0.

2.3.4.1 Binary Input Points

All Binary Input Status points are included in class 0 polls, because they are included in one of classes 1, 2 or 3.

Point Index	Name/Description	Initial value	Changes Event class (1,2,3)
0	Gen Strt	0	1
1	St Dif L1	0	1
2	St Dif L2	0	1
3	St Dif L3	0	1
4	St HV REF	0	1
5	St LV REF	0	1
6	St HV L1	0	1
7	St HV L2	0	1
8	St HV L3	0	1
9	St LV L1	0	1
10	St LV L2	0	1
11	St LV L3	0	1
12	St HV I>1	0	1
13	St HV I>2	0	1
14	St HV I>3	0	1
15	St LV I>1	0	1
16	St LV I>2	0	1
17	St LV I>3	0	1
18	St HVI2>1	0	1
19	St HVI2>2	0	1
20	St HVI2>3	0	1
21	St LVI2>1	0	1
22	St LVI2>2	0	1
23	St LVI2>3	0	1
24	StHVIN1>1	0	1
25	StHVIN1>2	0	1
26	StHVIN1>3	0	1
27	StLVIN1>1	0	1
28	StLVIN1>2	0	1

Point Index	Name/Description	Initial value	Changes Event class(1,2,3)
29	StLVIN1>3	0	1
30	StHVIN2>1	0	1
31	StHVIN2>2	0	1
32	StHVIN2>3	0	1
33	StLVIN2>1	0	1
34	StLVIN2>2	0	1
35	StLVIN2>3	0	1
36	THOL Alm	0	1
37	St HV CBF	0	1
38	HV I>BCBF	0	1
39	St LV CBF	0	1
40	LV I>BCBF	0	1
41	ThrougFlt	0	1
42	HV TCSAlm	0	1
43	HVCBOprAL	0	1
44	HVCBOpnSp	0	1
45	HVClsFail	0	1
46	HVOpnFail	0	1
47	LV TCSAlm	0	1
48	LVCBOprAL	0	1
49	LVCBOpnSp	0	1
50	LVClsFail	0	1
51	LVOpnFail	0	1
52	Opto I/P 1	0	2
53	Opto I/P 2	0	2
54	Opto I/P 3	0	2
55	Opto I/P 4	0	2
56	Opto I/P 5	0	2
57	Opto I/P 6	0	2
58	Strt Diff	0	1
59	Diff Trip	0	1
60	DifHS1Trp	0	1
61	DifHS2Trp	0	1
62	HV Ext Trip	0	1
63	LV Ext Trip	0	1
64	Gen Trip	0	1
65	Tr Dif L1	0	1
66	Tr Dif L2	0	1
67	Tr Dif L3	0	1
68	Dif HS1L1	0	1
69	Dif HS1L2	0	1
70	Dif HS1L3	0	1
71	Dif HS2L1	0	1
72	Dif HS2L2	0	1

Point Index	Name/Description	Initial value	Changes Event class(1,2,3)
73	Dif HS2L3	0	1
74	Tr HV REF	0	1
75	Tr LV REF	0	1
76	Tr HV L1	0	1
77	Tr HV L2	0	1
78	Tr HV L3	0	1
79	Tr LV L1	0	1
80	Tr LV L2	0	1
81	Tr LV L3	0	1
82	Tr HV I>1	0	1
83	Tr HV I>2	0	1
84	Tr HV I>3	0	1
85	Tr LV I>1	0	1
86	Tr LV I>2	0	1
87	Tr LV I>3	0	1
88	Tr HVI2>1	0	1
89	Tr HVI2>2	0	1
90	Tr HVI2>3	0	1
91	Tr LVI2>1	0	1
92	Tr LVI2>2	0	1
93	Tr LVI2>3	0	1
94	TrHVIN1>1	0	1
95	TrHVIN1>2	0	1
96	TrHVIN1>3	0	1
97	TrLVIN1>1	0	1
98	TrLVIN1>2	0	1
99	TrLVIN1>3	0	1
100	TrHVIN2>1	0	1
101	TrHVIN2>2	0	1
102	TrHVIN2>3	0	1
103	TrLVIN2>1	0	1
104	TrLVIN2>2	0	1
105	TrLVIN2>3	0	1
106	THOL Trip	0	1
107	Tr HVCBF	0	1
108	Tr LVCBF	0	1
109	Relay OK	0	1
110	Test Mode	0	1
111	LED Reset	0	2

2.3.4.2 Binary Output Status Points and Control Output Blocks

The following table lists both the Binary Output Status Point (Object 10) and the Control Relay Output Blocks (Objects 12).

Binary Output Status Points Object Number: 10 Request Function Codes supported: 1 (read) Default Variation reported when variation 0 requested: 2 (Binary Output Status)			
Control Relay Output Blocks Object Number: 12 Request Function Codes supported: 3 (select), 4 (operate),5 (direct operate), 6 (direct operate, noack)			
Point Index	Name/Description	Initial status value	Supported control relay output block fields
0	LED Reset	0	Pulse ON
1	HV CB Trip	0	Pulse ON
2	HV CB Close	0	Pulse ON
3	LV CB Trip	0	Pulse ON
4	LV CB Close	0	Pulse ON
5	Output 1	0	Pulse ON
6	Output 2	0	Pulse ON
7	Output 3	0	Pulse ON
8	Output 4	0	Pulse ON
9	Output 5	0	Pulse ON
10	Output 6	0	Pulse ON

2.3.4.3 Binary Counters

The following table lists Binary Counters (Object 20). All binary counter points are included in class 0 polls, because they are included in one of classes 1, 2 or 3.

Binary Counters Static (Steady-State) Object Number: 20 Change Event Object Number: 22 Request Function Codes supported: 1 (read) Static Variation reported when variation 0 requested: 5 (32-bit, unsigned integer count value without flag) Change Event Variation reported when variation 0 requested: 1 (32-bit, unsigned integer count value, with flag)			
Point Index	Name/Description	Initial value	Initial Change Event Class (1, 2, 3 or none)
0	TC	0	3
1	BOC-HV	0	3
2	BOC-LV	0	3

2.3.4.4 Analog Inputs

The following table lists Analog Inputs (Object 30). All Analog Input point is included in class 0 polls, because they are included in one of classes 1, 2 or 3.

Analog Inputs
 Static (Steady-State) Object Number: **30**
 Change Event Object Number: **32**
 Request Function Codes supported: **1 (read)**
 Static Variation reported when variation 0 requested: **1 (32-Bit Analog Input w/o flag)**
 Change Event Variation reported when variation 0 requested: **1 (32-Bit Analog Change Event w/o Time)**
 Change Event Scan Rate: The scan rate for analog input change events is fixed at 1s

Point Index	Name/Description	Initial value	Initial Change Event Class (1, 2, 3 or none)
0	IA-HV	0	3
1	IB-HV	0	3
2	IC-HV	0	3
3	IN-HV	0	3
4	IA-LV	0	3
5	IB-LV	0	3
6	IC-LV	0	3
7	IN-LV	0	3
8	I0-HV	0	3
9	I1-HV	0	3
10	I2-HV	0	3
11	I0-LV	0	3
12	I1-LV	0	3
13	I2-LV	0	3
14	IA-HV RMS	0	3
15	IB-HV RMS	0	3
16	IC-HV RMS	0	3
17	IA-LV RMS	0	3
18	IB-LV RMS	0	3
19	IC-LV RMS	0	3
20	IA-BIAS	0	3
21	IA-DIFF	0	3
22	IB-BIAS	0	3
23	IB-DIFF	0	3
24	IC-BIAS	0	3
25	IC-DIFF	0	3
26	Th State%	0	3
27	BOT-HV	0	3
28	BOT-LV	0	3
29	IREF HV LoZ BIAS	0	3

Point Index	Name/Description	Initial value	Initial Change Event Class (1, 2, 3 or none)
30	IREF HV LoZ DIFF	0	3
31	IREF LV LoZ BIAS	0	3
32	IREF LV LoZ DIFF	0	3
33	IREF HV	0	3
34	IREF LV	0	3

Note 3: The measurands transmitted by the relay are sent as a primary values.

*Note 4: The measurement value transmitted by relay in **pu** is displayed as multiplied by 100.*

INSTALLATION

CHAPTER 11

1 CHAPTER OVERVIEW

This chapter consists of the following sections:

- 1 Chapter Overview**
- 2 Installation**
 - 2.1 Handling the goods
 - 2.1.1 Receipt of the goods
 - 2.1.2 Unpacking the goods
 - 2.1.3 Storing the goods
 - 2.1.4 Dismantling the goods
 - 2.2 Mounting the device
 - 2.2.1 Flush panel mounting
 - 2.3 Relay connection
 - 2.3.1.1 Relay operating condition
 - 2.3.1.2 Current transformer (CT) circuit
 - 2.3.1.3 Insulation and dielectric strength testing
 - 2.3.2 Cables and connectors
 - 2.3.3 Terminal blocks
 - 2.3.3.1 CT/Auxiliary power/Input/Output connections
 - 2.3.3.2 Rear serial port connection
 - 2.3.3.3 Power supply connections
 - 2.3.3.4 Earth connection
 - 2.3.3.5 Current transformers
 - 2.3.3.6 EIA(RS) 485 Connections
 - 2.3.3.7 Output relay connections
 - 2.3.3.8 USB connection
 - 2.4 Case dimensions

2 INSTALLATION

2.1 Handling the goods

Our products are of robust construction but require careful treatment before installation on site. This section discusses the requirements for receiving and unpacking the goods, as well as associated considerations regarding product care and personal safety.



Caution: Before lifting or moving the equipment you should be familiar with the Safety Information chapter of this manual.

2.1.1 Receipt of the goods

On receipt, ensure the correct product has been delivered. Unpack the product immediately to ensure there has been no external damage in transit. If the product has been damaged, make a claim to the transport contractor and notify us promptly.

For products not intended for immediate installation, repack them in their original delivery packaging.

2.1.2 Unpacking the goods

When unpacking and installing the product, take care not to damage any of the parts and make sure that additional components are not accidentally left in the packing or lost. Do not discard any CDROMs or technical documentation. These should accompany the unit to its destination substation and put in a dedicated place.

The site should be well lit to aid inspection, clean, dry and reasonably free from dust and excessive vibration. This particularly applies where installation is being carried out at the same time as construction work.

2.1.3 Storing the goods

If the unit is not installed immediately, store it in a place free from dust and moisture in its original packaging. Keep any de-humidifier bags included in the packing. The de-humidifier crystals lose their efficiency if the bag is exposed to ambient conditions. Restore the crystals before replacing it in the carton. Bags should be placed on flat racks and spaced to allow circulation around them. The time taken for regeneration will depend on the size of the bag. If a ventilating, circulating oven is not available, when using an ordinary oven, open the door on a regular basis to let out the steam given off by the regenerating silica gel. On subsequent unpacking, make sure that any dust on the carton does not fall inside. Avoid storing in locations of high humidity. In locations of high humidity the packaging may become impregnated with moisture and the de-humidifier crystals will lose their efficiency.

The device can be stored between -25° to $+70^{\circ}\text{C}$.

2.1.4 Dismantling the goods

If you need to dismantle the device, always observe standard ESD (Electrostatic Discharge) precautions.

The minimum precautions to be followed are as follows:

- Use an antistatic wrist band earthed to a suitable earthing point.
- Avoid touching the electronic components and PCBs.

2.2 Mounting the device

The products are available for flush panel mounting only

2.2.1 Flush panel mounting

The P652 supports flush panel mounting and can be mounted into panels using fitting clamps with M5 X 10 screws.

The fitting clamp and screws are supplied along with the relay.

For mounting the relay in to the panel follow this procedure:

1. By loosening the M5 x 10 screws, remove the fitting clamps on the relay and then insert the Relay in to the panel cut-out as show below.

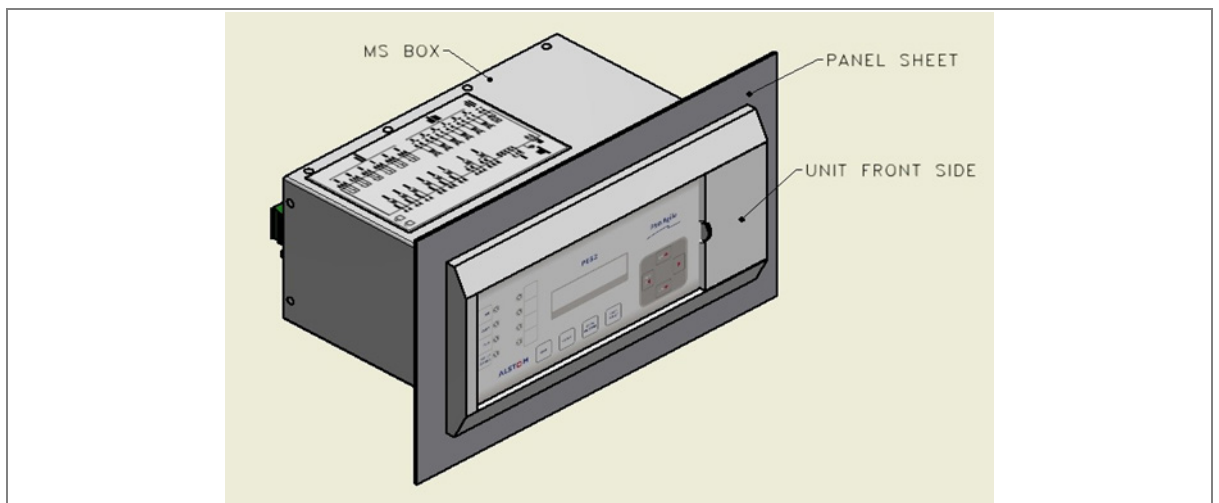

Figure 1: Inserting relay in to the panel cutout

2. After inserting the relay in the panel using the fitting clamps and the M5 x 10 screws, fasten the relay to the panel as shown below.

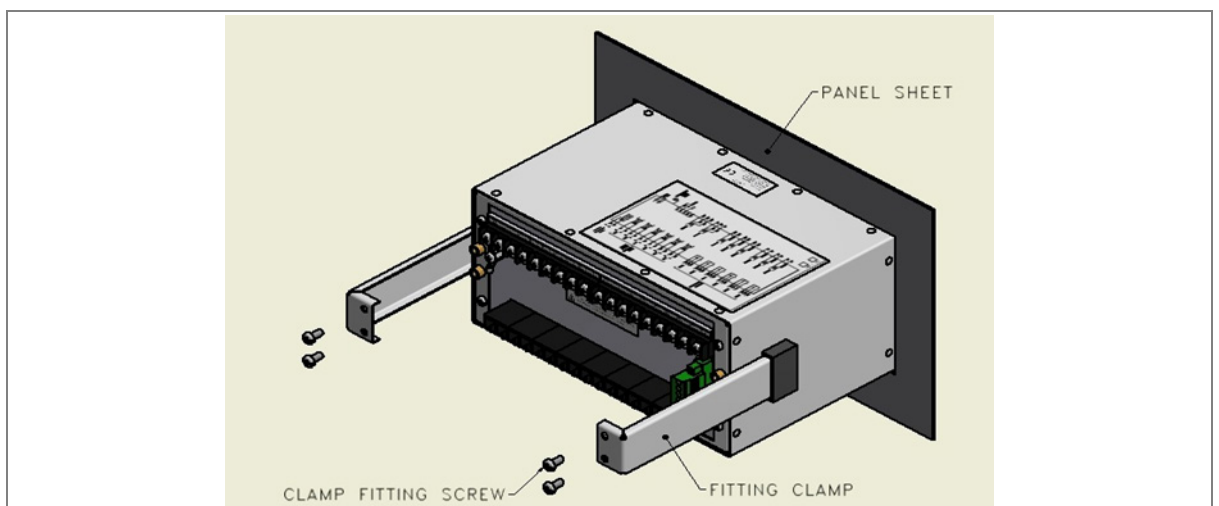

Figure 2: Tightening fitting clamps



Caution: All screws of fitting clamps to be properly tightened. Always use M5x10 screws for fitting the clamps.

- The relay after fastening to the panel with the help of fitting clamps and the M5 x 10 screws is shown below.

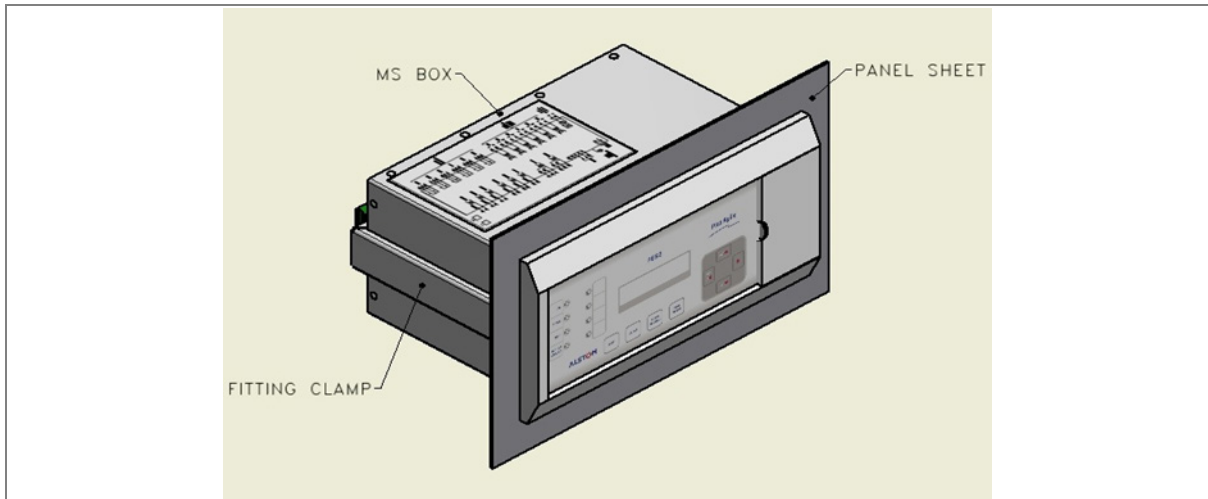

Figure 3: Relay mounted on the panel-front view

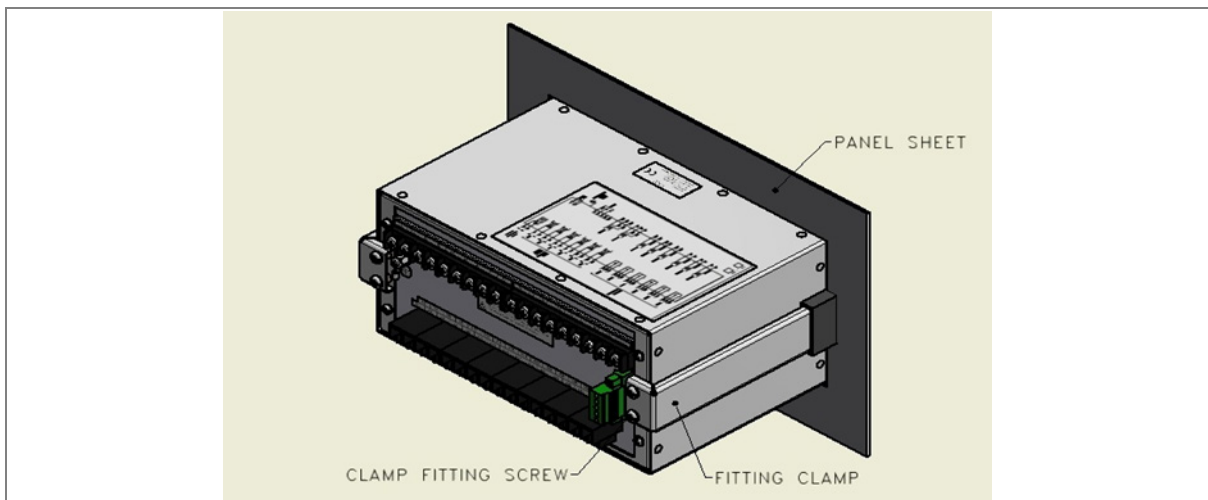

Figure 4: Relay mounted on the panel-rear view

2.3 Relay connection

Before installation of the relay check the correct working procedure to ensure safety. The Terminal exposed during installation may present a hazardous voltage unless the equipment is electrically isolated. Any disassembly of the equipment may expose parts to hazardous voltage. Electronic parts may be damaged if suitable electrostatic discharge (ESD) precautions are not taken. Voltage and current connection should be made using insulated crimp termination to ensure that terminal block insulation requirements are maintained for safety. To ensure that wires are correctly terminated the correct crimp terminal and tool for wire size should be used. The equipment must be connected in accordance with the appropriate connection diagram.

Before energizing the following should be checked

1. Voltage rating and polarity.
2. CT circuit rating and integrity of connection.
3. Protective fuse rating.
4. Integrity of the earthing connection.
5. Voltage and current rating of external wiring, applicable as per application.

2.3.1.1 Relay operating condition

The equipment should be operated within the specified electrical and environmental limits.

2.3.1.2 Current transformer (CT) circuit

Do not open the secondary circuit of a live CT as the high voltage produce may be lethal to personnel and could damage insulation. Generally, for safety, the secondary of the line CT must be shorted before opening any connection to it.

2.3.1.3 Insulation and dielectric strength testing

Insulation testing may leave capacitors charged up to a hazardous voltage. At the end of each part test, the voltage should be gradually reduced to zero, to discharge capacitors, as this may result in damage.

2.3.2 Cables and connectors

This section describes the type of wiring and connections that should be used when installing the device. For pin-out details please refer to the wiring diagrams.



Caution: Before carrying out any work on the equipment you should be familiar with the Safety Section and the ratings on the equipment's rating label.

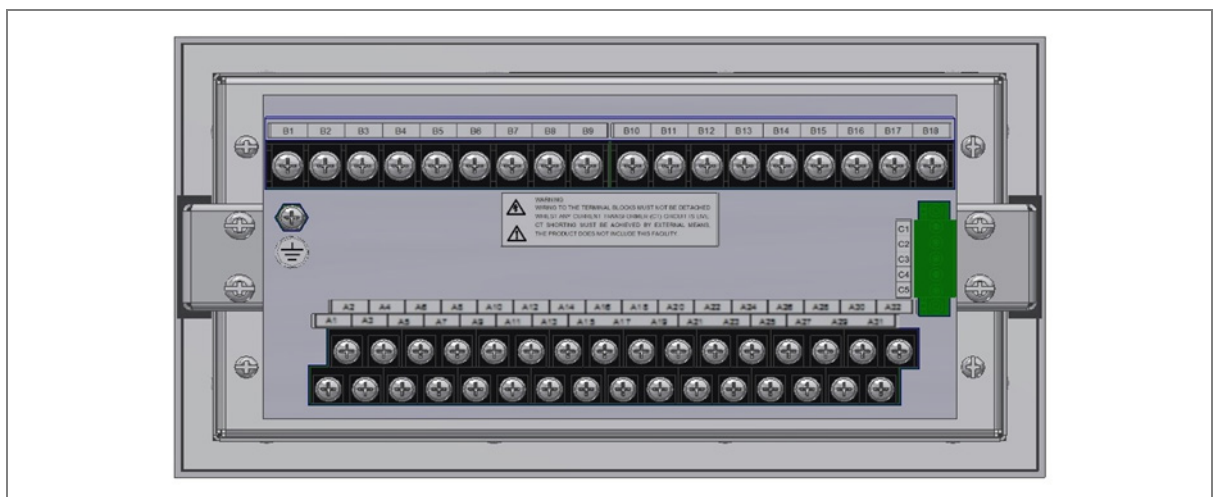

Figure 5: P652 rear view-terminal connection

2.3.3 Terminal blocks

2.3.3.1 CT/Auxiliary power/Input/Output connections

The P50 Agile devices use terminal blocks as shown below. The terminal block consists of up to 18 x M5 screw terminals and 32 x M4 screw terminals. M5 terminal blocks are used for CT connections and M4 terminal blocks are used for auxiliary power/ input/output connections. The wires should be terminated with rings using 90° ring terminals, with no more than two rings per terminal. The product is supplied with sufficient M5 & M4 screws for proper connection.

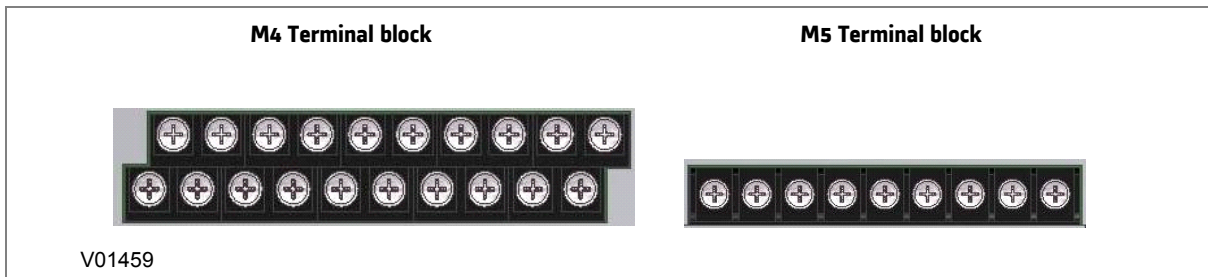

Figure 6: Terminal blocks



Caution: Always fit an insulating sleeve over the ring terminal.

2.3.3.2 Rear serial port connection

The rear serial port is intended for use with a permanently wired connection to a remote SCADA system. The physical connectivity is achieved using three screw terminals: C3, C4 terminals for signal connection, and C5 terminal for connecting cable shield. The terminal block is located at the rear of the relay as shown below.

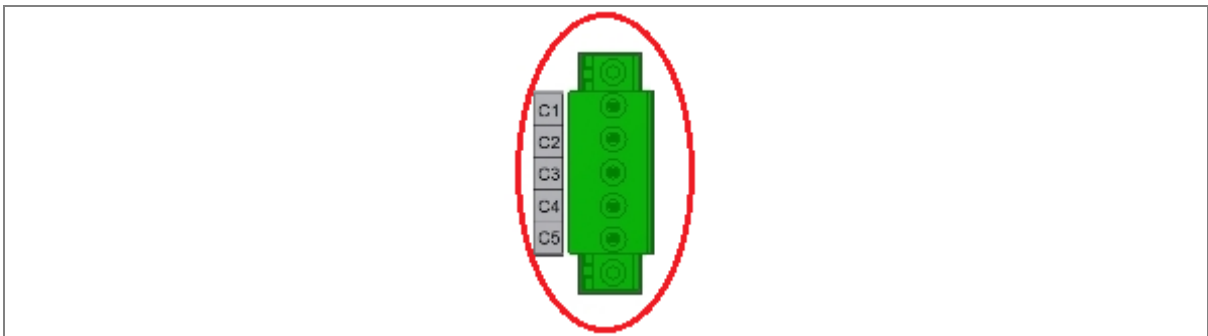

Figure 7: Rear serial port terminal block

2.3.3.3 Power supply connections

These should be wired with 1.5 mm PVC insulated multi-stranded copper wire terminated with M4 ring terminals. The wire should have a minimum voltage rating of 300 V RMS.

As per the application, in case auxiliary supply input of the relay needs to be wired, then adequate care should be taken to wire as per polarity marking on the Terminal sticker at the rear of the relay. The supply range is also mentioned on the Terminal sticker and before energising, care should be taken to confirm that the auxiliary supply being wired is within range.

2.3.3.4 Earth connection

Every device must be connected to the cubicle earthing bar. The earthing terminal is provided on back side of the relay. Ensure that the relay earthing is connected to the local earth bar. With several relays present; make sure that the copper earth bar is properly installed for solidity connecting to the earthing terminal of each relay equipment box.

Before energizing the equipment it must be earthed using the protective conductor terminal, (if provided) or the appropriate termination of the supply plug in the case of plug connected equipment. The protective conductor (earth) connection must not be removed since the protection against electric shock provided by the equipment would be lost. The recommended minimum protective conductor (earth) wire size is 2.5 mm² or as per industries standard practice. The protective conductor (earth) connection must be of low-inductance and as short as possible.

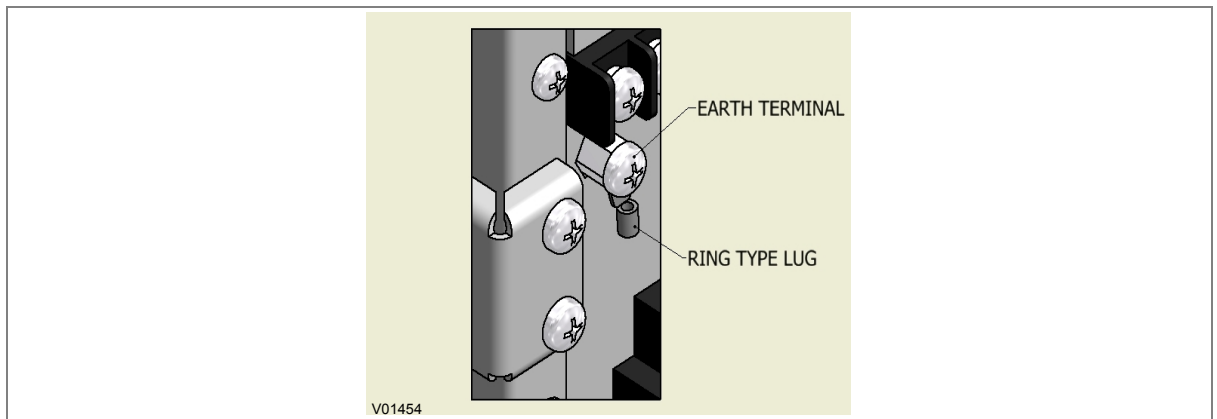

Figure 8: Earthing terminal on the rear side of the relay

Note: To prevent any possibility of electrolytic action between brass or copper ground conductors and the rear panel of the product, precautions should be taken to isolate them from one another. This could be achieved in several ways, including placing a nickel-plated or insulating washer between the conductor and the product case, or using tinned ring terminals.

2.3.3.5 Current transformers

Current transformers would generally be wired with 2.5 mm² PVC insulated multi-stranded copper wire terminated with M5 ring terminals. The wires should be terminated with rings using 90° rings terminals, with no more than two rings per terminal.

Due to the physical limitations of the ring terminal, the maximum wire size you can use is 4.0 mm² using ring terminals.

The wire should have a minimum voltage rating of 300 V RMS.



Caution: Current transformer circuits must never be fused.

Note 1: Terminal blocks must not be detached whilst any current transformer (CT) circuit is live. CT shorting must be achieved by external means; the product does not include this facility.

Note 2: For 5A CT secondary, we recommend using 2 x 2.5 mm² PVC insulated multi-stranded copper wire.

2.3.3.6 EIA(RS) 485 Connections

For connecting the EIA (RS485), use 2-core screened cable with a maximum total length of 1000 m or 200 nF total cable capacitance.

A typical cable specification would be:

- Each core: 16/0.2 mm² copper conductors, PVC insulated
- Nominal conductor area: 0.5 mm² per core
- Screen: Overall braid, PVC sheathed

There is no electrical connection of the cable screen to the device. The link is provided purely to link together the two cable screens.

2.3.3.7 Output relay connections

These should be wired with 1 mm PVC insulated multi-stranded copper wire terminated with M4 ring terminals.

2.3.3.8 USB connection

The IED has a type B USB socket on the front panel. A standard USB printer cable (type A one end, type B the other end) can be used to connect a local PC to the IED. This cable is the same as that used for connecting a printer to a PC.

2.4 Case dimensions

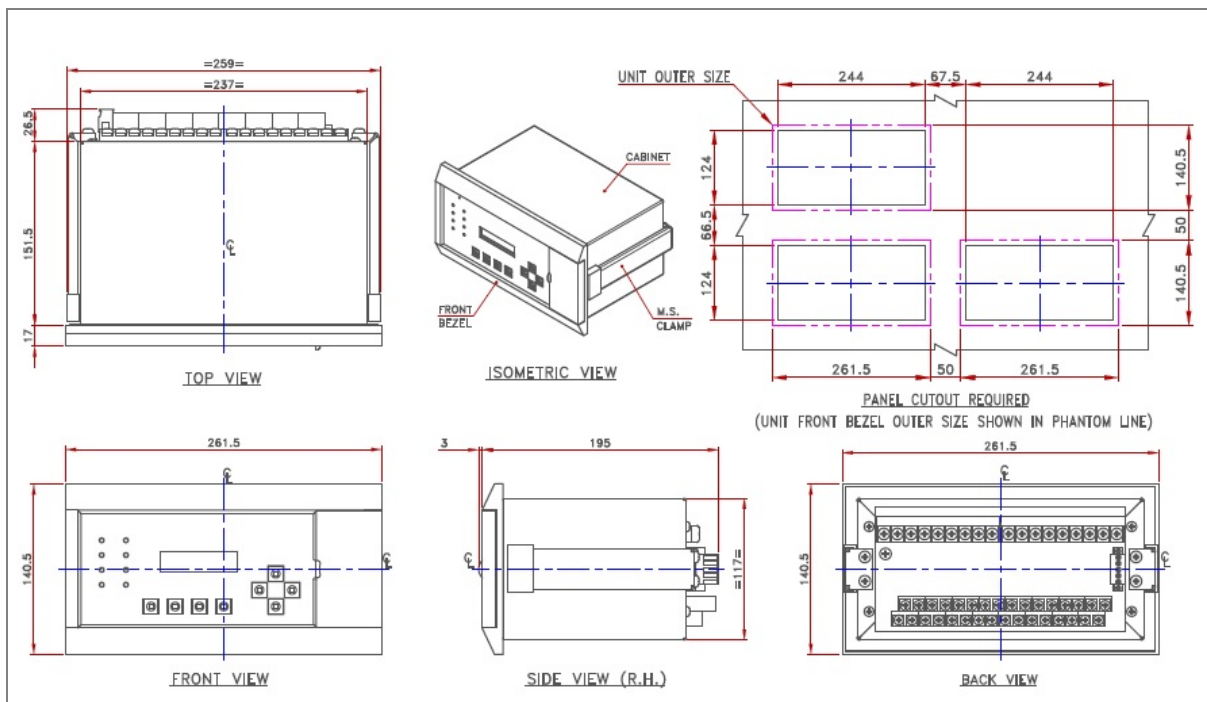

Figure 9: P652 case dimensions

Note: All dimensions are in mm.

COMMISSIONING INSTRUCTIONS

CHAPTER 12

1 CHAPTER OVERVIEW

This chapter consists of the following sections:

- 1 Chapter Overview**
- 2 Commissioning**
 - 2.1 Commissioning Test Menu
 - 2.1.1 Test Mode
 - 2.1.2 Test Pattern
 - 2.1.3 Contact Test
 - 2.1.4 Test LEDs
 - 2.1.5 Opto input status check
 - 2.1.6 Opto output status check
 - 2.1.7 Commissioning test equipment required
 - 2.1.8 Battery check
 - 2.1.9 External circuitry check
 - 2.1.9.1 Earthing
 - 2.1.9.2 CT Polarity
 - 2.1.10 Secondary injection tests
 - 2.1.10.1 Test current inputs
 - 2.1.10.2 Check polarity of three phase CTs
 - 2.1.11 Relay settings check
 - 2.1.12 Checking the differential element
 - 2.1.13 Protection timing checks
 - 2.1.13.1 Overcurrent check
 - 2.1.13.2 Connecting the test circuit
 - 2.1.13.3 Performing the test
 - 2.1.13.4 Operating time check
 - 2.1.14 Onload checks
 - 2.1.14.1 Confirm current connections
 - 2.1.15 Final checks

2 COMMISSIONING

The P652 is fully numerical in its design - it has self-supervision function which continuously keeps track of its internal hardware, and it will display a message on the LCD screen if it detects the failure of any component. This is why the commissioning tests are less extensive than those for non-numeric electronic devices or electromechanical relays.

2.1 Commissioning Test Menu

The IED provides several test facilities under the **COMMISSION TEST** menu heading. There are menu cells that allow you to monitor the status of the opto-inputs, output relay contacts, and user-programmable LEDs.

This section describes the commissioning tests available in the IED's Commissioning test menu.

2.1.1 Test Mode

The Test Mode menu cell is used to allow secondary injection testing to be performed on the relay itself without operation of the trip contacts. It also enables a facility to test the output contacts by applying menu controlled test signals.

To select test mode, the **Test Mode** menu cell should be set to **Test Mode**, which takes the relay out of service and blocks the maintenance, counters. It also causes an alarm condition to be recorded and the amber **OUT OF SERVICE** LED to illuminate. This also freezes any information stored in the CB Condition column and in IEC 60870-5-103 builds changes the Cause of Transmission, COT, to Test Mode.

To enable testing of output contacts the **Test Mode** cell should be set to **Contacts Blocked**. This blocks the protection from operating the contacts and enables the test pattern and contact test functions which can be used to manually operate the output contacts.

Once testing is complete the cell must be set back to **Disabled** to restore the relay back to service.

2.1.2 Test Pattern

This cell is used to select the output relay contacts that will be tested when the **Contact Test** cell is set to **Apply Test**.

2.1.3 Contact Test

When the **Apply Test** command in this cell is issued, the contacts set for operation (set to 1) in the Test Pattern cell change state. After the test has been applied, the command text on the LCD will change to **No Operation** and the contacts will remain in the Test State until reset issuing the **Remove Test** command. The command text on the LCD will again revert to **No Operation** after the **Remove Test** command has been issued.

2.1.4 Test LEDs

When the Apply Test command in this cell is issued, the 4 programmable LEDs will illuminate for approximately 2 seconds before they extinguish and the command text on the LCD reverts to **No Operation**.

2.1.5 Opto input status check

The **Opto I/P** cell under **SYSTEM DATA** menu can be used to monitor the status of the opto-inputs while they are sequentially energised with a suitable voltage. The cell is a binary string that displays the status of the opto-inputs where '1' means energised and '0' means de-energised.

2.1.6 Opto output status check

The **Opto O/P** cell under **SYSTEM DATA** menu can be used to monitor the status of the relay outputs. The cell is a binary string that displays the status of the relay outputs where '1' means energised and '0' means de-energised. The cell indicates the status of the output relays when the IED is in service. You can check for relay damage by comparing the status of the output contacts with their associated bits.

Note: When the Test Mode cell is set to Contacts Blocked, the relay output status indicates which contacts would operate if the IED was in-service. It does not show the actual status of the output relays, as they are blocked.

2.1.7 Commissioning test equipment required

At the time of commissioning the P652, the following test equipment is required as a minimum:

- Current injection test kit
- Multimeter with suitable AC current range and DC voltage range.
- Timer with precision 1 ms.
- Required auxiliary supply.
- Connecting wire, as per required length extension board etc.
- A portable PC, installed with appropriate software (P50 Agile Configurator)

2.1.8 Battery check

If the relay is losing its time or date settings or you are receiving a message of RTC Error, then this may require checking internal battery. Follow the steps below:

- Remove all the electrical connection (like SCADA system, current inputs, voltage inputs, etc.) from the relay terminals.
- Reconfigure date and time setting by using the feather touch keys.
- After re-configuring the date and time, switch OFF the relay for some time by disconnecting the auxiliary supply.
- Switch ON the relay, and check its date and time. If you are still receiving the RTC Error message, then replace the lithium coin battery. (Refer to instructions in the **Maintenance and Troubleshooting** chapter)

2.1.9 External circuitry check

Check the relay wiring on the back terminal of relay against the appropriate wiring diagram:

1. CT secondary must be connected to the relay 1A or 5A. All CT wiring screws should be properly tightened.



Warning: An open circuit of the CT secondary wiring can cause high voltage which may be lethal and could damage insulation.

2. External supply can be wired to the relay auxiliary supply terminals with proper polarity marking as mentioned on the Terminal sticker at the top of the relay. The supply range is mentioned under the front flap covering the USB port connection. Confirm that the auxiliary supply is in range before energizing the relay.

3. The Trip Coil contact connection should be as per the given schematic diagram.
4. Latching type annunciation contact connection as per requirement of site.

2.1.9.1 Earthing

An earthing terminal is provided at the back of the relay. Make sure that the case earthing connections are used to connect the IED to a local earth bar using an adequate conductor.

With several relays present, make sure that the copper earth bar is properly installed for solidity connecting to the earthing terminal of each relay.

2.1.9.2 CT Polarity

Ensure proper CTs are connected as per required maximum load current and their polarity. When all CTs are connected with proper polarity and sequence, unbalance current flowing through earth fault element will be approximately zero. Otherwise the relay will trip on earth fault when the CB is energized.

2.1.10 Secondary injection tests

Secondary injection testing is carried out to verify the integrity of the CT readings. All devices leave the factory set for operation at a system frequency of 50 Hz. If operation at 60 Hz is required, you must set this in the Frequency cell in the **SYSTEM DATA** column.

Connect the current outputs of the test set to the appropriate terminals of the first current channel and apply nominal current.

2.1.10.1 Test current inputs

This test verifies that the current measurement inputs are configured correctly.

All devices leave the factory set for operation at a system frequency of 50 Hz. If operation at 60 Hz is required, you must set this in the Frequency cell in the **SYSTEM DATA** column.

1. Using secondary injection test equipment such as an Omicron, apply and measure nominal rated current to each CT in turn.
2. Check its magnitude using a multi-meter or test set readout. Check this value against the value displayed on the HMI panel (usually in **MEASUREMENTS 1** column).
3. Record the displayed value. The measured current values will either be in primary or secondary Amperes. If the Measure't Values cell is set to 'Primary', the values displayed should be equal to the applied current multiplied by the corresponding current transformer ratio (set in the **TRANS. RATIOS** column). If the Measure't Values cell is set to 'Secondary', the value displayed should be equal to the applied current.

The measurement accuracy of the IED is +/- 2%. However, an additional allowance must be made for the accuracy of the test equipment being used.

2.1.10.2 Check polarity of three phase CTs

This test checks the polarity of all three-phase CTs associated with a winding.

1. Apply the same current to phases A, B, and C, phase displaced as for a balanced 3-phase set with standard ABC phase rotation (phase A = 0°, phase B = -120°, phase C = +120°).
2. Starting from CT input 1, apply the balanced current and check the measured residual current in the relevant cell. This will be **IN-HV or IN-LV** depending on the transformer winding to which the current input is assigned.

3. The residual current measured should be as per technical claims. If high residual current is measured, one or more of the CT circuits for the end concerned may have a problem (for example, an inverted connection). Repeat the same test on the rest of the CT inputs

2.1.11 Relay settings check

The relay setting check ensures that all of the application-specific settings for the particular installation have been correctly applied to the relay. Enter all settings manually via the front panel interface or using P50 Agile configurator tool.

2.1.12 Checking the differential element

Testing of the differential element during commissioning is not necessary unless explicitly requested.

To avoid spurious operation of any other protection elements, all protection elements except the transformer differential protection should be disabled for the duration of the differential element tests. This is done in the product's **CONFIGURATION** column. Make a note of which elements need to be re-enabled after testing.

The following tests demonstrate correct operation of the differential protection. Testing should be performed on individual current inputs of each phase and on each winding, but note that the timing test should only be performed on the high voltage winding. Testing the low-set element is sufficient to test the correct operation of the differential protection.

Using a suitable current injection method, slowly increase the current from 0 Amps and note the pick-up value at which the element operates. Reduce the current slowly and note the drop-off value at which it resets. Check that the pick-up and drop-off are within the range shown in the table.

Pickup/Drop-off	Current level
Pick-up	$0.90 \times I_n$ to $1.1 \times I_n$
Drop-off	$0.90 \times \text{pick-up}$ to $1 \times \text{pick-up}$

where $I_n = I_{s1}/(\text{amplitude matching factor})$. Also take into consideration of HV/LV Grounding setting, if enabled, for arriving the actual pick-up.

and I_{s1} is the low set setting which can be found in the I_{s1} cell in the **DIFF PROTECTION** column.

The amplitude matching factor is used to compensate for a mismatch in currents due to the line side current transformer ratios. There is one amplitude matching factor for the high-voltage side and one for the low-voltage side. You will find these in the **SYSTEM CONFIG** column. Use the appropriate amplitude matching factor to calculate the required injection current. This depends on whether it is being injected into the HV or LV current transformer inputs.

1. While connected to the HV windings, connect the output contacts for the low set differential protection function to trip the test set and also to stop a timer.
2. Configure the test set so that when the current is applied, the timer starts.
3. Inject $5 \times I_n$ into the HV CT input.
4. Check that the element operates within technical claims value and record the time.

Note: If this test has been successfully performed there is no need to carry out the tests described in the protection timing checks section

2.1.13 Protection timing checks

There is no need to check every protection function. Only one protection function needs to be checked as the purpose is to verify the timing on the processor is functioning correctly.

2.1.13.1 Overcurrent check

If the overcurrent protection function is being used, test the overcurrent protection for stage 1.

1. Check for any possible dependency conditions and simulate as appropriate.
2. In the **CONFIGURATION** menu, disable all protection elements other than the one being tested.
3. Make a note of which elements need to be re-enabled after testing.
4. Connect the test circuit
5. Perform the test
6. Check the operating time

2.1.13.2 Connecting the test circuit

1. Identify the function associated with the overcurrent protection stage 1 trip.
2. Use the output relay RL1 for assigning the overcurrent trip function
3. Use the IO Masking function in the P50 Configurator or IO configuration menu on relay HMI to map the protection stage under test directly to an output relay.
4. Connect the output relay so that its operation will trip the test set and stop the timer.
5. Connect the current output of the test set to the A-phase current transformer input.
6. Ensure that the timer starts when the current is applied.

2.1.13.3 Performing the test

1. Ensure that the timer is reset.
2. Apply a current of twice the setting shown in the **I>1 Current Set** cell in the **HV (LV) OVERCURRENT** menu.
3. Note the time displayed when the timer stops.
4. Check that the red trip LED has illuminated.

2.1.13.4 Operating time check

Check that the operating time recorded by the timer is within the range shown below.

For all characteristics, allowance must be made for the accuracy of the test equipment being used.

Characteristic	Operating time at twice current setting and time multiplier/ time dial setting of 1.0	
	Nominal (seconds)	Range (seconds)
DT	I>1 Time Delay setting	Setting $\pm 5\%$ or 55ms whichever is greater
IEC S Inverse	10.03	Please refer to the Technical Specifications chapter for operating time accuracy
IEC V Inverse	13.50	
IEC E Inverse	26.67	
UK LT Inverse	20.00	
IEEE M Inverse	3.8	
IEEE V Inverse	7.03	
IEEE E Inverse	9.50	
US Inverse	2.16	
US ST Inverse	12.12	

Note: With the exception of the definite time characteristic, the operating times given are for a Time Multiplier Setting (TMS) or Time Dial Setting (TDS) of 1. For other values of TMS or TDS, the values need to be modified accordingly



Caution: On completion of the tests, you must restore all settings that were disabled

2.1.14 Onload checks

Onload checks can only be carried out if there are no restrictions preventing the energisation of the plant, and the other devices in the group have already been commissioned.

Remove all test leads and temporary shorting links, then replace any external wiring that has been removed to allow testing.



Caution: If any external wiring has been disconnected for the commissioning process, replace it in accordance with the relevant external connection or scheme diagram.

2.1.14.1 Confirm current connections

1. Measure the current transformer secondary values for each input using a multimeter connected in series with the corresponding current input.
2. Check that the current transformer polarities are correct by measuring the negative sequence current magnitude or derived earth fault current.
3. Ensure the current flowing in the neutral circuit of the current transformers is negligible.
4. Compare the values of the secondary phase currents with the measured values, which can be found in the **MEASUREMENTS** menu.

The 'Secondary' values displayed on the relay should be equal to the applied secondary current. The values should be within 2% of the applied secondary Current. However, an additional allowance must be made for the accuracy of the test equipment being used.

2.1.15 Final checks

1. Remove all test leads and temporary shorting leads.
2. If you have had to disconnect any of the external wiring in order to perform the wiring verification tests, replace all wiring, fuses and links in accordance with the relevant external connection or scheme diagram.
3. Ensure that the IED has been restored to service by checking that the **Test Mode** cell in the **COMMISSION TESTS** menu is set to 'Disabled' .
4. The settings applied should be carefully checked against the required application-specific settings to ensure that they are correct, and have not been mistakenly altered during testing.
5. Ensure that all protection elements required have been set to **Enabled** in the **CONFIGURATION** menu.
6. If the IED is in a new installation or the circuit breaker has just been maintained, the circuit breaker maintenance and current counters should be zero. These counters can be reset using the **Clear Maint** function in the **RECORD CONTROL** menu.
7. If the required access level is not active, the device will prompt for a password to be entered so that the setting change can be made.

8. If a P991/MMLG test block is installed, remove the P992/MMLB test plug and replace the cover so that the protection is put into service.
9. Ensure that all event records, fault records, disturbance records, alarms and LEDs and communications statistics have been reset.

Note: **Clear Maint** function will clear all Maintenance record memory.

MAINTENANCE AND TROUBLESHOOTING

CHAPTER 13

1 CHAPTER OVERVIEW

This chapter consists of the following sections:

- 1 Chapter Overview**
- 2 MAINTENANCE**
 - 2.1 Maintenance checks
 - 2.1.1 Opto-Isolators
 - 2.1.2 Output Relays
 - 2.1.3 Measurement Accuracy
 - 2.2 Changing the battery
 - 2.2.1 Instructions to replace the lithium coin battery
 - 2.3 Replacing the Unit
 - 2.4 Cleaning
- 3 Troubleshooting**

2 MAINTENANCE

2.1 Maintenance checks

In view of the critical nature of the application, GE Vernova products should be checked at regular intervals to confirm they are operating correctly.

The devices are self-supervising and so require less maintenance than earlier designs of protection devices. Most problems will result in an alarm, indicating that remedial action should be taken. However, some periodic tests should be carried out to ensure that they are functioning correctly and that the external wiring is intact. It is the responsibility of the customer to define the interval between maintenance periods. If your organisation has a Preventative Maintenance Policy, the recommended product checks should be included in the regular program. Maintenance periods depend on many factors, such as:

- The operating environment
- The accessibility of the site
- The amount of available manpower
- The importance of the installation in the power system
- The consequences of failure

Although some functionality checks can be performed from a remote location, these are predominantly restricted to checking that the unit is measuring the applied currents and voltages accurately, and checking the circuit breaker maintenance counters. For this reason, maintenance checks should also be performed locally at the substation.



Caution: Before carrying out any work on the equipment you should be familiar with the contents of the Safety Section or the Safety Guide Pxxx-SG-4LM-1 and the ratings on the equipment's rating label.

2.1.1 Opto-Isolators

Check the opto-inputs by repeating the commissioning test detailed in the Commissioning chapter.

2.1.2 Output Relays

Check the output relays by repeating the commissioning test detailed in the Commissioning chapter.

2.1.3 Measurement Accuracy

If the power system is energised, the measured values can be compared with known system values to check that they are in the expected range. If they are within a set range, this indicates that the A/D conversion and the calculations are being performed correctly. Suitable test methods can be found in Commissioning chapter.

Alternatively, the measured values can be checked against known values injected into the device using the test block, (if fitted) or injected directly into the IED's terminals. These tests will prove the calibration accuracy is being maintained.

2.2 Changing the battery

The P652 relay has a battery to maintain status data and the correct time when the auxiliary supply voltage fails.

The data maintained includes event, fault and disturbance records and the thermal state at the time of failure. The battery periodically needs changing if there is a low battery condition, to ensure reliability. The lithium coin battery is located on the CPU PCB.



Caution: Before carrying out any work on the equipment you should be familiar with the contents of the Safety Section or the Safety Guide Pxxx-SG-4LM-1 and the ratings on the equipment's rating label.

2.2.1 Instructions to replace the lithium coin battery

1. Remove the relay cover by loosening the screws as shown in figure below.

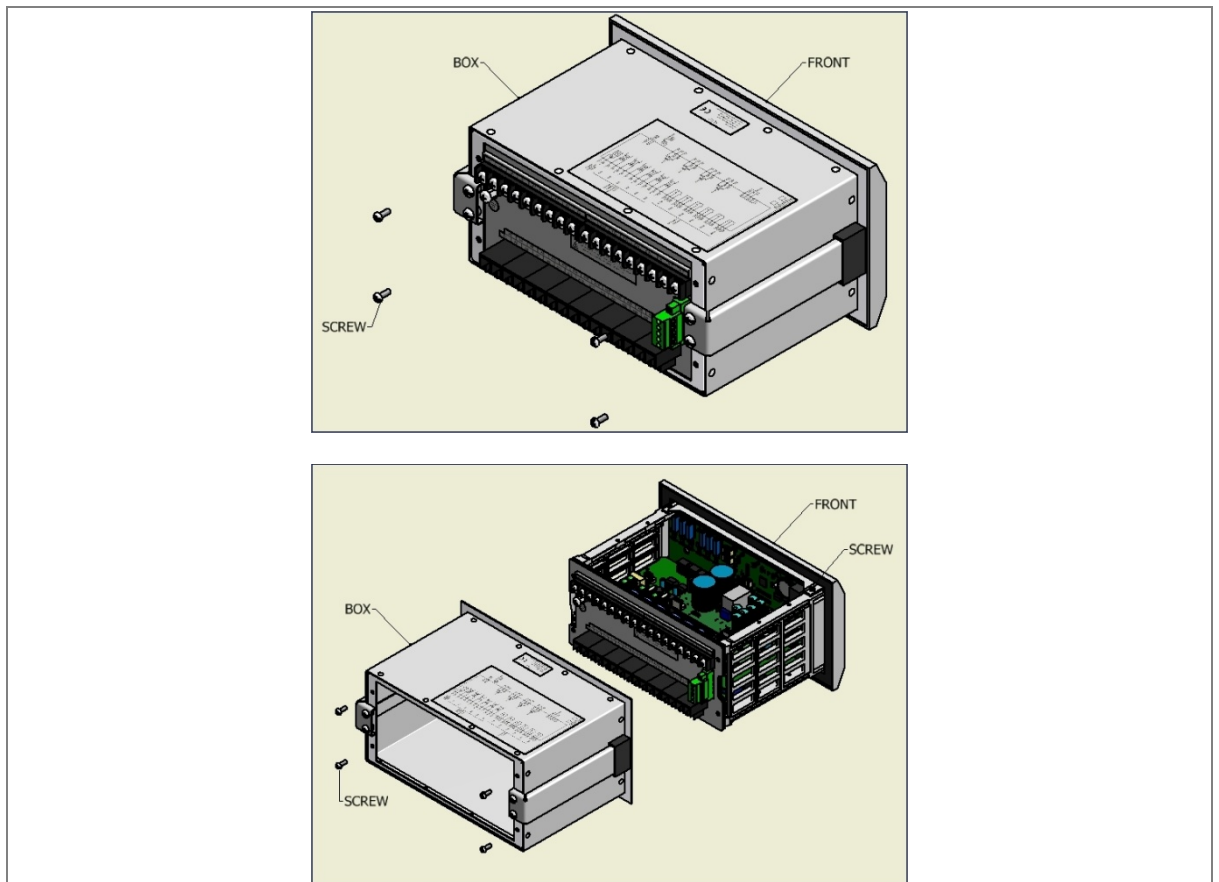

Figure 1: Removal of relay cover

2. Remove the front bezel by loosening the screws as shown in figure below.

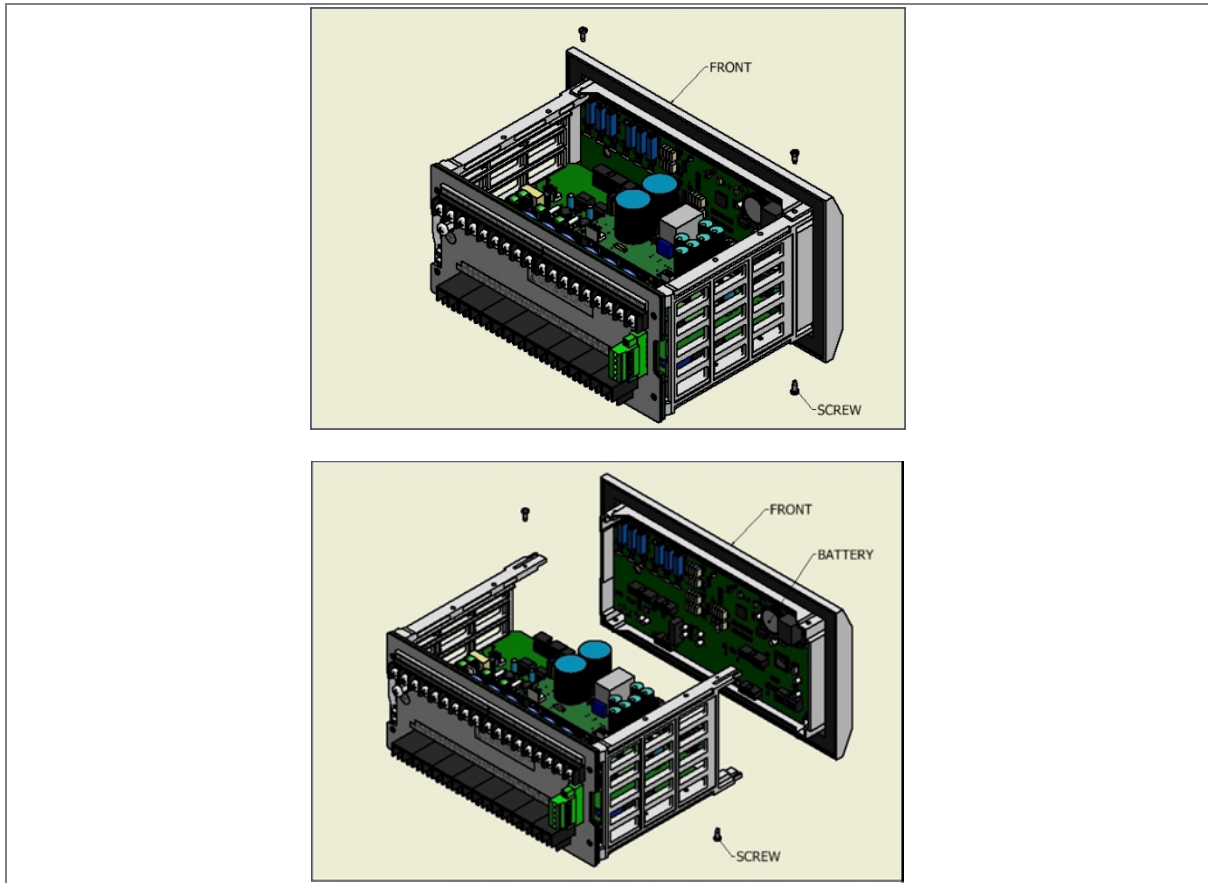

Figure 2: Removal of front bezel

3. Locate the exact position of the lithium coin battery on the CPU PCB

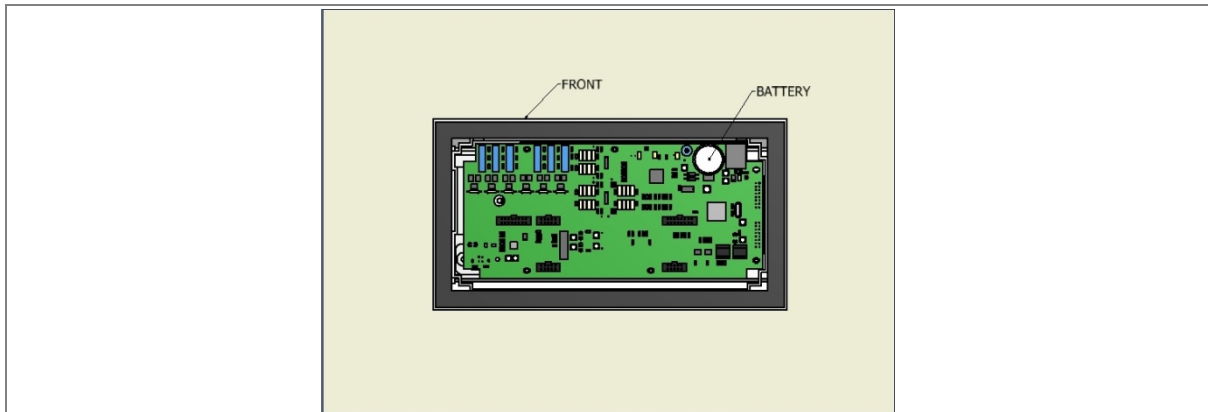

Figure 3: Battery location on CPU PCB

4. Gently remove the battery. If necessary, use a small insulated screwdriver.
5. Make sure the metal terminals in the battery socket are free from corrosion, grease and dust.
6. Remove the replacement battery from its packaging and insert it in the battery holder, ensuring correct polarity. Orient the lithium coin battery so that the positive (+) side is visible.

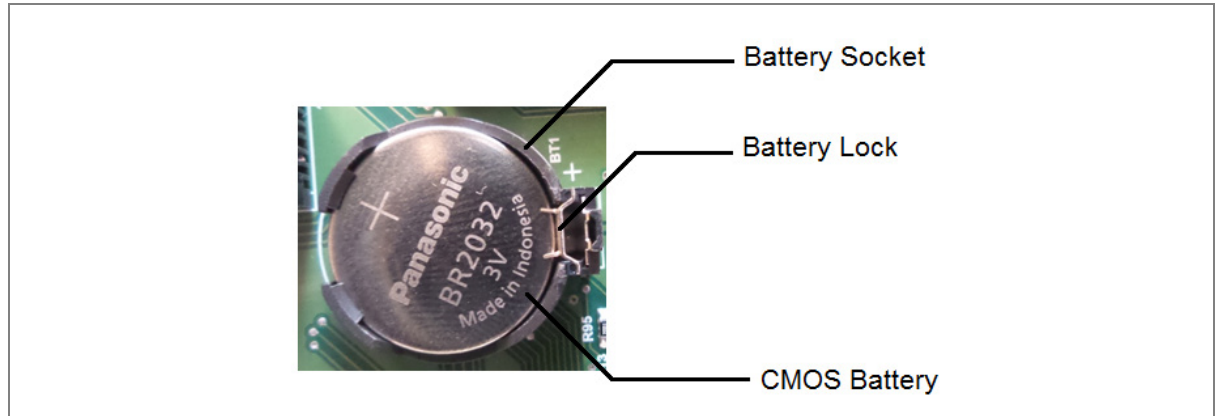

Figure 4: Correct polarity of battery



Only use Panasonic make Lithium battery type BR2032 or equivalent with a nominal voltage of 3 V.

7. Ensure that the battery is held securely in its socket and that the battery terminals make good contact with the socket terminals.
8. Replace the front bezel and relay cover.
9. After replacing the lithium coin battery, you must reconfigure and reset the system date and time.

2.3 Replacing the unit

If your product should develop a fault while in service, depending on the nature of the fault, the error codes will be generated which can be viewed on the relay HMI. First step is to take actions as suggested in the Troubleshooting section of this manual. In the unlikely event that the problem persists or lies with the wiring and/or terminals, then you must replace the complete device, rewire and re-commission the device.

Once the unit has been reinstalled, it should be re-commissioned.



Caution: If the repair is not performed by an approved service centre, the warranty will be invalidated.



Caution: Before carrying out any work on the equipment, you should be familiar with the contents of the Safety Information section of this guide or the Safety Guide Pxxx-SG-4LM-1 as well as the ratings on the equipment's rating label. This should ensure that no damage is caused by incorrect handling of the electronic components.



Warning: Before working at the rear of the unit, isolate all voltage and current supplying it.

Note: P652 does not support automatic current transformer shorting. Therefore for safety reasons CT terminals to be shorted when the terminal block is removed.

2.4 Cleaning



Warning: Before cleaning the IED, ensure that all AC and DC supplies and transformer connections are isolated to prevent any chance of an electric shock while cleaning.

Only clean the equipment with a lint-free cloth dampened with clean water. Do not use detergents, solvents or abrasive cleaners as they may damage the product's surfaces and leave a conductive residue.

3 TROUBLESHOOTING

The relay continuously monitors the hardware and detects any hardware fault/error. In case of hardware failure relay displays the corresponding error code on the LCD.

- The IED performs continuous periodic self-diagnostic procedure at every one minute for checking of all errors excluding Setting Error.
- If the error is cleared during self-diagnostic procedure, corresponding error bit will be cleared.
- For Setting Error, ADC Error and FRAM1 Error, the IED goes in **OUT OF SERVICE** mode (Protection will be blocked). The **OUT OF SERVICE** LED on the front facia will continuously blink at 1 sec interval and **ON** LED indication will turn from GREEN to RED.

The errors are stored in the 'Main't Rec Num= "and can be viewed from **Maint Record** submenu. Error code is stored in 16 bit integer.

The bit definition applicable to P652 is as under:

Bit 12 - 15	Bit 11	Bit 10	Bit 6-9	Bit 5	Bit 4	Bit 3	Bit 2	Bit 1	Bit 0
Unused	Incompatible Firmware	Incompatible CommFirmware	Unused	FRAM 1 Error	ADC Error	Unused	RTC Error	Unused	Setting Error

Error code descriptions are given below:

Sr. No	Error code display	Error Data Bitwise	Description	Cause	Action taken by MCU	Proposed action for user
1	0001	0000 0000 0000 0001	SETTING Error	<ol style="list-style-type: none"> 1. Setting corrupted 2. Change of Setting address in memory 	ON LED turns Red and OUT OF SERVICE LED starts blinking. (Protection is blocked)	Go to CONFIGURATION menu, restore default settings and then save settings. Press (EDIT + PROT. RESET).
2	0004	0000 0000 0000 0100	RTC Error	<ol style="list-style-type: none"> 1. I2C Bus Error 2. Damaged RTC 3. Battery backup not functioning 	ON LED turns Red	Set correct values for Date & Time and press (EDIT + PROT. RESET).
3	0010	0000 0000 0001 0000	ADC Error	<ol style="list-style-type: none"> 1. ADC device not working. 2. SPI bus error 	ON LED turns Red and OUT OF SERVICE LED starts blinking. (Protection is blocked)	Press (EDIT + PROT. RESET)

Sr. No	Error code display	Error Data Bitwise	Description	Cause	Action taken by MCU	Proposed action for user
4	0020	0000 0000 0010 0000	FRAM 1 Error	1. SPI bus error 2. FRAM not working	ON LED turns Red and OUT OF SERVICE LED starts blinking.	Press (EDIT + PROT. RESET)
5	Incompatible CommFirmware	0000 0100 0000 0000	Incompatible CommFirmware Error	Firmware being flashed is incompatible with the protocol option as per relay model number.	ON LED turns Red	Flash correct FW as per the cortec information on the relay.
6	Incompatible Firmware	0000 1000 0000 0000	Incompatible Firmware Error	Firmware being flashed is incompatible with the hardware option as per relay model number (e.g. mismatch in CT selection / DI Input threshold voltage etc.)	ON LED turns Red and OUT OF SERVICE LED starts blinking. (Protection is blocked)	Flash correct FW as per the cortec information on the relay.

TECHNICAL SPECIFICATIONS

CHAPTER 14

1 CHAPTER OVERVIEW

This chapter consists of the following sections:

- 1 **Chapter Overview**
- 2 **Technical Specification**
 - 2.1.1 Standards compliance

2 TECHNICAL SPECIFICATION

Current Input					
I.	CT secondary	1 A or 5 A (Ordering option for Phase CTs)			
II.	Nominal burden at rated current (without tripping condition)	< 0.20 VA at rated current (In)			
III.	Thermal withstand capacity	100 x rated current (In) for 1s 50 x rated current (In) for 3s 4 x rated current (In) continuous for Phase and REF CT			
IV.	Measurement linearity range (for non – offset AC current)	For O/C : 0.05 – 40 In For REF : 0.05 – 40 In			
V.	Measurement accuracy	Typical $\pm 2\%$ at In for Phase and REF CTs			
VI.	Nominal frequency range for current Inputs	50/60 Hz (selectable in P652 Menu)			
VII.	Frequency measurement range	45 Hz – 65 Hz			
Auxiliary Supply					
I.	Nominal auxiliary voltage	24-230 V AC (50 / 60 Hz) or 24-230 V DC			
II.	Operating range	80% of lower nominal range and 120% of upper nominal range for DC supply 80% of lower nominal range and 110% of upper nominal range for AC supply			
III.	Nominal burden on 24 – 230 V auxiliary power supply	24-230 V AC	< 12 VA (no status energized) < 15 VA (with all status and outputs energised)		
		24-230 V DC	< 5 W (no status energized) < 6 W (with all status and outputs energised)		
IV.	Tolerable ac ripple	Up to 15% of highest dc supply, as per IEC 60255-26: 2013			
V.	Relay power up time with auxiliary supply	< 2.50s			
Opto Isolated Input					
I.	Nominal operating voltage range	24-230 V AC (50 / 60 Hz) or 24-230 V DC			
II.	Threshold setting (ordering option)	Option -1*	Option -2	Option -3	Option -4
	Threshold voltage for DC	18V +/- 3V	35V +/- 3V	77V +/- 3V	154V +/- 3V
	Threshold voltage for AC	16V +/- 3V	33V +/- 3V	75V +/- 3V	152V +/- 3V
	Maximum operating voltage range	276VDC / AC	276VDC / AC	276VDC / AC	276VDC / AC
		<i>*Note: The inputs must be connected via screened cable or twisted pair cable.</i>			
III.	Drop out	Within 85% of threshold voltage value			
IV.	VA burden of opto inputs	For each status < 1.5 W / VA			
V.	Filtering time	< 40 ms			
VI.	Logic input recognition time	For all status inputs: filtering time + 5 ms \pm 5 ms			

Output Contact			
I.	Non Latching contact	Continuous	5A/250 V AC or 5A/220 V DC
		Make & carry (AC/DC)	30A for 3s
		Short time withstand capacity (AC/DC)	50A for 1s
		Breaking capacity	AC- 1250 VA max., 5A or 250 V (PF= 0.4)
			DC- 100 W resistive max., 5A or 300 V 50 W Inductive (L/R =45 ms) max., 5A or 300 V
		Operating time	<10ms
Minimum no. of operations	10,000 operation loaded condition & unloaded 100,000 operations		
Accuracy of protection function			
Overcurrent (HV and LV)			
I.	Operating value	Pick-up	Setting $\pm 5\%$
		Minimum trip level (IDMT)	1.05 x Setting $\pm 5\%$
		Drop-off	0.95 x Setting $\pm 5\%$
II.	Operating time	IDMT characteristic shape	As per clause 5.2 of IEC60255-151 or 50 ms whichever is greater
		DT operation	$\pm 5\%$ or 55ms whichever is greater**
		** Reference condition	Currents applied at 2x pick-up level or higher
III.	Reset time	DT	Set delay $\pm 7.5\%$ or 55ms whichever is greater
		IDMT (only for IEEE & US curves)	Calculated time $\pm 10\%$
Earth Fault (HV and LV) – Measured / Derived			
I.	Operating value	Pick-up	Setting $\pm 5\%$
		Minimum trip level (IDMT)	1.05 x Setting $\pm 5\%$
		Drop-off	0.95 x Setting $\pm 5\%$
II.	Operating time	IDMT characteristic shape	As per clause 5.2 of IEC60255-151 or 50 ms whichever is greater
		DT operation	$\pm 5\%$ or 55ms whichever is greater**
		** Reference condition	Currents applied at 2x pick-up level or higher
III.	Reset time	DT	Set delay $\pm 7.5\%$ or 55ms whichever is greater
		IDMT (only for IEEE & US curves)	Calculated time $\pm 10\%$
Negative Phase Sequence Overcurrent (HV and LV)			
I.	Operating value	Pick-up	Setting $\pm 5\%$
		Minimum trip level (IDMT)	1.05 x Setting $\pm 5\%$
		Drop-off	0.95 x Setting $\pm 5\%$
II.	Operating time	IDMT characteristic shape	As per clause 5.2 of IEC60255-151 or 50 ms whichever is greater
		DT operation	$\pm 5\%$ or 55 ms whichever is greater**
		** Reference condition	Currents applied at 2x pick-up level or higher

III.	Reset time	DT	Set delay $\pm 7.5\%$ or 55ms whichever is greater
		IDMT (only for IEEE & US curves)	Calculated time $\pm 10\%$
Transformer Differential			
I.	Operating value	Pick-up	Calculated difference $\pm 5\%$ or 20 mA (1A input), or 100mA (5A input) whichever is greater
		Drop-off	0.95 of formula $\pm 5\%$
II.	Operating time	DT operation	< 55 ms (Currents applied at 2x pick-up level or higher)
		High Set-1 (Is-HS1)	<40 ms (Currents applied at 2x pick-up level or higher)
		High Set-2 (Is-HS2)	<40 ms (Currents applied at 2x pick-up level or higher)
III.	Harmonic Blocking	2 nd Harm Thresh	Setting $\pm 15\%$
		5 th Harm Thresh	Setting $\pm 15\%$
High Impedance REF (HV and LV)			
I.	Operating value	Pick-up	Setting +10% / -5%
		Drop-off	0.95 x Setting $\pm 5\%$
II.	Operating time	DT operation	< 30 ms **
		** Reference condition	Currents applied at 2x pick-up level or higher
Low Impedance REF (HV and LV)			
I.	Operating value	Pick-up	Calculated difference $\pm 5\%$ or 20 mA (1A input), or 100 mA (5A input) whichever is greater
		Drop-off	0.95 of formula $\pm 5\%$
II.	Operating time	DT operation	< 55ms **
		** Reference condition	Currents applied at 2x pick-up level or higher
Thermal Overload (HV and LV)			
I.	Operating time	Thermal Trip	$\pm 10\%$ of calculated time
CB Fail (HV and LV)			
I.	Operating time	DT operation	$\pm 5\%$ or 55ms whichever is greater**
		CBF Reset	<40 ms*
		Reset current	Setting $\pm 10\%$
		** Reference condition	Currents applied at 2x pick-up level or higher
* Note : Filtering time (typically 25ms) is added when CBF initiated by external binary input			
2nd Harmonic (HV and LV)			
I.	Operating value	IH2 HV SET (for HV) IH2 LV SET (for LV)	Setting $\pm 15\%$
		I>lift 2H HV (for HV) I>lift 2H LV (for LV)	Setting $\pm 15\%$
Through fault monitoring			
I.	Operating value	Monitored Input current threshold	Setting $\pm 15\%$ or 20 mA (1A input), or 100 mA (5A input) whichever is greater

Note: As per IEC60255-151 clause 5.2 (assigned error 5%) the tolerance calculated as below.

Value of characteristic quantity as multiple of setting value (Gs)	2-5	5-10	Above 10
Limiting error as multiple of an assigned error	2.5	1.5	1

Operating conditions		
I.	Relative humidity	Humidity (RH) 95% maximum
II.	Operating temperature range	-25 °C to +55 °C
III.	Storage temperature range	-25 °C to +70 °C
Terminals specification		
I.	AC current input terminals	M5 threaded terminals for ring lug connection. Suitable up to 4 mm ²
II.	Auxiliary & input/output Terminals	M4 threaded terminal connection. Suitable up to 2.5 mm ²
III.	Tightening torque for M4/M5 screws	Maximum torque of 1.2 Nm
IV.	Rear communication terminal	Two wire connection. Suitable up to 2.5 mm ²
Mechanical & Environmental specification		
I.	Design	Flush mounting case
II.	Weight	3.50 Kg approximate
III.	Pollution Degree	II

2.1.1 Standards compliance

SR. NO.	TYPE TEST	STANDARD	TEST SPECIFICATION/METHOD	
1.	Impulse, Dielectric and Insulation tests			
1.1	Impulse voltage test	IEC 60255-27:2005 (incl. corrigendum 2007)	Test voltage	5kv, 1.2/50 μ V
			Energy	0.5 J
			Polarity	+ve and -ve
			No. of impulses	3 on each polarity
			Duration between impulses	5 s
			EUT condition	Non energised
1.2	Dielectric voltage withstand test	IEC 60255-27:2005 (incl. corrigendum 2007)	1) 2 kV rms AC, 1 minute between all terminals connected together with case earth. 2) 2 kV rms AC, 1 minute between independent circuits with case earth. 3) 1.5 kV rms AC, 1 minute across open contacts of changeover output relays.	
1.3	Insulation resistance test	IEC 60255-27:2005 (incl. corrigendum 2007)	> 100 M Ω at 500 V DC	
1.4	Creepage distances and clearances	IEC 60255-27:2005 (incl. corrigendum 2007)	Pollution degree : 2 Overvoltage category : III	

2.		Auxiliary Supply tests		
2.1	D.C. voltage dips	IEC 61000-4-29 Class A IEC60255-26(ed3.0): 2013	Residual voltage 1) At 40% for 200 ms. 2) At 70% for 500 ms.	
2.2	DC voltage interruption	IEC 61000-4-29 Class A IEC60255-26(ed3.0): 2013	1) DC auxiliary supply interruptions for 10, 20 ms with no loss of protection. 2) DC auxiliary supply interruptions for 30 ms, 50 ms, 100 ms, 200 ms, 0.5 s, 1 s, 5 s with temporary loss of protection.	
2.3	AC voltage dips	IEC 61000-4-11 Class A IEC60255-26(ed3.0): 2013	Residual voltage 1) At 40% for 200 ms. 2) At 70% for 500 ms. 3) At 80% for 5 s.	
2.4	A.C. voltage interruption	IEC 61000-4-11 Class A IEC60255-26: 2013	1) AC auxiliary supply interruptions for 10 ms, 20 ms with no loss of protection. 2) AC auxiliary supply interruptions for 50 ms, 100 ms, 200 ms, 0.5 s, 5 s with temporary loss of protection.	
2.5	AC (ripple) in DC supply	IEC 60255-11, IEC60255-26(ed3.0): 2013	Level: 15% Frequency: 100/120 Hz	
2.6	Gradual shutdown/ start-up test	IEC60255-26(ed3.0): 2013	The unit must power down and up correctly with no mal-operation.	
			Shut down time	60 sec.
			Power off time	5 min.
			Startup time	60 sec.
2.7	Reversal of DC power supply polarity test	IEC 60255-11	Product shall withstand for 1 minute with reverse polarity of power supply inputs.	
3.		Emission tests		
3.1	Radiated emission test	EN55022:2006+A1:2007 IEC60255-26(ed3.0): 2013	The EUT shall satisfy the requirement of this specification. Radiation measured at a distance of 10 meter.	
			Frequency range	Limits
			30 MHz – 230 MHz	40 dB (µV/m)
			230 MHz – 1000 MHz	47 dB (µV/m)
	EUT condition	Energised		
3.2	Conducted emission test	IEC60255-26(ed3.0): 2013	The EUT shall satisfy the requirement of this specification.	
			Frequency range	Limits
			0.15 – 0.5 MHz	79 dB/µV (Quasi peak)
				66 dB/µV (Average)
			0.5 – 30 MHz	73 dB/µV (Quasi peak)
60 dB/µV (Average)				
	EUT Condition	Energised		

4.		Immunity tests		
4.1	High frequency disturbance test	IEC 60255-22-1 and IEC60255-26(ed3.0): 2013	1) 2.5 kV Common mode a) Between independent circuits and case earth. b) Independent circuits. 2) 1 kV Differential mode a) Independent circuits. EUT condition : Energised	
4.2	Electrostatic discharge	EN61000-4-2:2009 Level 3 and Level 4 IEC60255-26(ed3.0): 2013	1) 15kV air discharge 2) 8kV contact discharge 3) 15kV indirect discharge EUT condition : Energised	
4.3	Surge immunity test	EN61000-4-5:2006 Level 4 IEC60255-26(ed3.0): 2013	1) 4KV: Power supply common mode 2) 2KV Power supply differential mode 3) 4KV CT / input / output ports common mode 4) 2KV CT / input / output ports differential mode EUT condition : Energised	
4.4	Fast transient	EN 61000-4-4:2004 + A1:2010 Level 4 IEC60255-26(ed3.0): 2013	1) 4 kV, 5 kHz and 100 kHz, applied to all circuits excluding communication ports 2) 2 kV, 5 kHz and 100 kHz, applied to communication ports EUT condition: Energised	
4.5	Radiated radio frequency electromagnetic field disturbance test	EN 61000-4-3: 2006 + A1:2008 Level 4, IEC60255-26(ed3.0) : 2013	Voltage level	10 V/m and 30 V/m
			Frequency range	
			• For 10 V/m	800 – 1000 MHz , 1.4 – 2.7 GHz
			• For 30 V/m	80 – 960 MHz , 1.4 – 2 GHz
			Modulation	80% AM @ 1 KHz
	Spot Frequency	80, 160, 380, 450, 900,1850 & 2150 MHz		
4.6	Conducted disturbance induced by radio Frequency field	EN 61000-4-6: 2009 Level 3 IEC60255-26(ed3.0): 2013	Voltage level	10 V
			Frequency range	0.15 – 80 MHz
			Modulation	80% AM @ 1 KHz
			Dwell time	2.85 Sec.
			Spot frequency	27, 68 MHz
4.7	Power frequency magnetic field immunity	EN61000-4-8:2010 Level 5 IEC60255-26(ed3.0): 2013	1) Class 5: 100 A/m field applied continuously in all planes for the EUT in a quiescent and tripping state 2) Class 5: 1000 A/m field applied for 3s in all planes for the EUT in a quiescent and tripping state EUT condition : Energized	
4.8	Pulsed magnetic field immunity	EN 61000-4-9:1993 +A1:2001, Level 5	Class 5: 1000 A/m field applied continuously in all planes for the EUT in a quiescent and tripping state	

4.9	Damped oscillatory magnetic field	EN61000-4-10:1993 + A1:2001, Level 5	Class 5: 100 A/m field applied in all planes at 100 kHz / 1 MHz with burst duration of 2s.	
4.10	Damped oscillatory test	EN 61000-4-18: 2007 + A1:2010	1) 100 kHz and 1 MHz slow damped oscillatory applied in common mode at 2.5 KV 2) 3 MHz, 10 MHz, 30 MHz fast damped oscillatory applied in common mode at 1 KV	
5.	Mechanical tests			
5.1	Vibration response test	EN 60255-21-1:1996 Class 2	Frequency range	10 Hz to 150 Hz
			Crossover frequency	58 to 60 Hz
			Peak displacement before crossover	0.075mm
			Peak acceleration after crossover	1 gn
			No. of sweep cycles per axis	1
			EUT condition	Energised
5.2	Vibration endurance test	EN 60255-21-1:1996 Class 2	Frequency range	10 to 250 Hz
			Peak acceleration	2 gn
			No. of sweep cycles per axis	20
5.3	Shock response test	EN 60255-21-2:1996 Class 2	Peak acceleration	10 gn
			Pulse duration	11 ms
			No. of pulses in each direction	5
5.4	Shock endurance test	EN 60255-21-2:1996 Class 2	Peak acceleration	30 gn
			Pulse duration	11 ms
			No. of pulses in each direction	3
5.5	Bump test	EN 60255-21-2:1996 Class 2	Peak acceleration	20 gn
			Pulse duration	16 ms
			No. of pulses in each direction	1000
5.6	Seismic test	EN 60255-21-3:1995 (Class 2 - 2g peak)	Frequency range	1 to 35 Hz
			Crossover frequency	8 Hz
			Peak displacement before crossover X	7.5 mm
			Peak displacement before crossover Y	3.5 mm

			Peak acceleration after crossover Y	1 gn
			No. of sweep cycles per axis	1
			EUT condition	Energised

6. Environmental tests				
6.1	Dry heat test	IEC 60068-2-2: 2007 Bd	Start-up +20°C (EUT energised)	Functional verification tests for 2 hours
			Intermediate +40°C (EUT energised)	Functional verification tests for 2 hours
			High temperature claim +65°C (EUT energised at highest rated voltage)	Operate for 96 hours at highest rated voltage (HRV)
			High temperature claim +70°C (EUT not energised)	Storage for 96 hours
			Hot start +65°C (EUT energised at highest rated voltage)	Operate for 2 hours at highest rated voltage (HRV)
			Last test +20°C (EUT energised)	Functional verification tests for 2 hours
6.2	Cold test	IEC 60068-2-1: 2007	Start-up +20°C (EUT energised)	Functional verification tests for 2 hours
			Intermediate 0°C (EUT energised)	Functional verification tests for 2 hours
			Intermediate -10°C (EUT energised)	Functional verification tests for 2 hours
			Low temperature -25°C (EUT energised)	Functional verification tests for 96 hours
			Low temperature -25°C (EUT not energised)	Storage for 96 hours
			Cold start -25°C (EUT energised)	Operate for 2 hours
			Last test +20°C (EUT energised)	Functional verification tests for 2 hours
6.3	Change of temperature test	EN 60068-2-14:2009	Lower temperature	-25°C
			Higher temperature	+65°C
			Rate of change of temperature	1°C/min
			Duration of exposure	5 cycle
			Duration of cycle	3 + 3 hrs.
			EUT condition	Energised
6.4	Damp heat steady state test	EN 60068-2-78, EN60068-2-30	Operating temperature	+40°C
			Humidity	93%
			Duration of exposure	10 days
			EUT condition	Energised
6.5	Damp heat cyclic test	IEC60068-2-30	Lower temperature	+25°C
			Humidity	97%
			Higher temperature	+40°C
			Humidity	93%
			Duration of exposure	6 cycle
			Duration of cycle	12 + 12 hrs.
EUT condition	Energised			

6.6	Enclosure protection	EN 60529:2000	IP52	For Front
			IP20	For Rear
			EUT condition	Non energised

WIRING DIAGRAMS

CHAPTER 15

1 CHAPTER OVERVIEW

This chapter consists of the following sections:

- 1 Chapter Overview**
- 2 Wiring diagram**

2 WIRING DIAGRAM

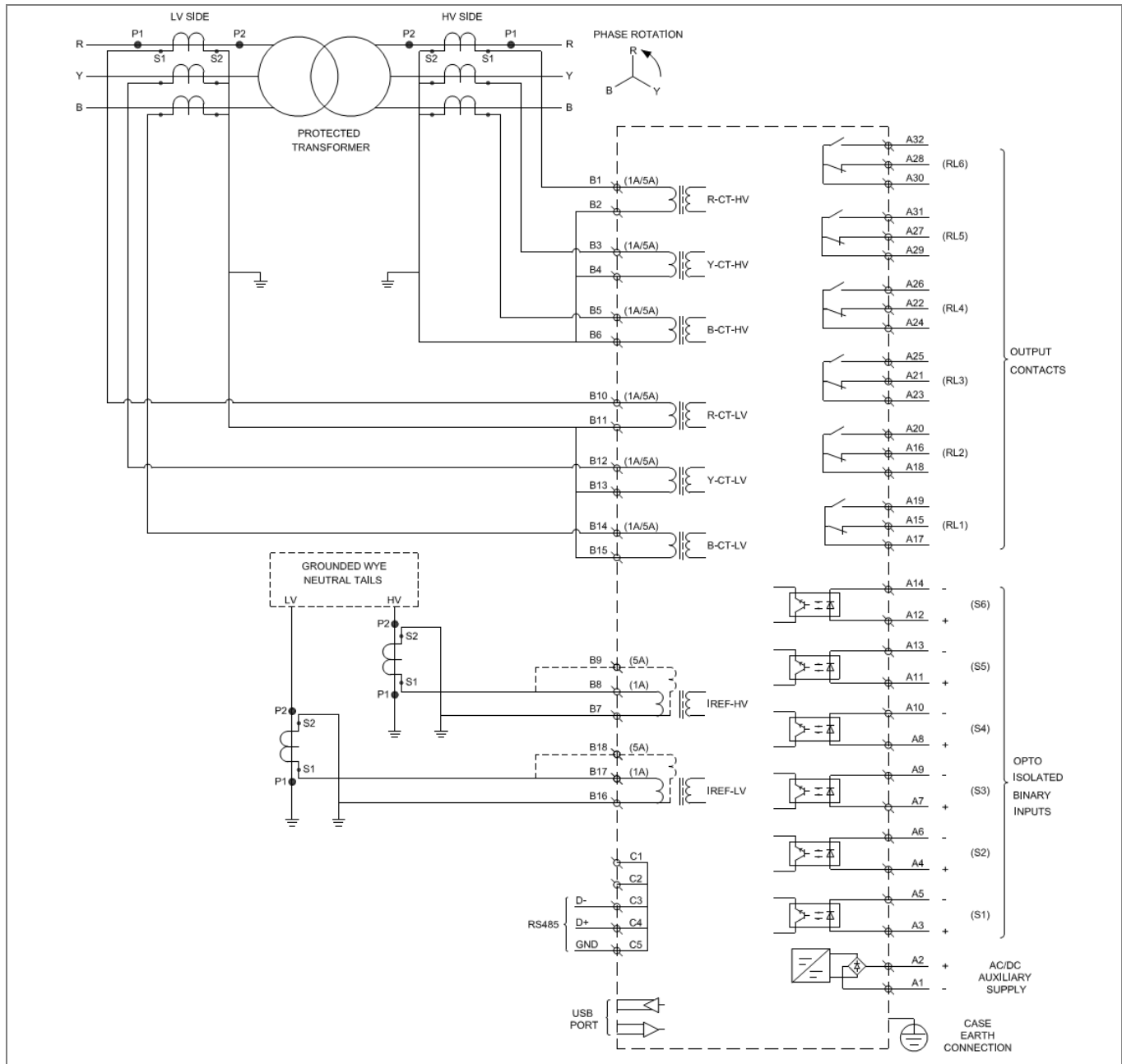

Figure 1: P652 wiring diagram



GE VERNOVA

Imagination at work

GE Vernova
St Leonards Building
Redhill Business Park
Stafford, ST16 1WT, UK
+44 (0) 1785 250 070
www.governova.com/grid-solutions/contact