

MICOM AGILE P64

5th Generation Advanced Transformer Protection, Control and Condition Monitoring



Transformers are high capital cost assets in electrical power systems. Internal faults are a risk for all transformers, with short-circuits dissipating the highest localized energy. Unless cleared quickly, the possibility of rewinding will diminish, and core damage may become irreparable.

The MicOM Agile P64 relay addresses all these issues – preserving service life and offering fast protection for transformer faults. A transient bias technique has been included, enhancing relay stability and CT requirements. CT saturation and no gap detection techniques have been included to improve the low set differential element operating time during CT saturation where the second harmonic blocking might be asserted. An external fault detection algorithm has been incorporated to prevent the CT saturation and no gap detection from affecting the second harmonic blocking when there is an external fault.

Hosted on the advanced MicOM 5th Generation platform, the P64 relay incorporates differential, REF, thermal, and overfluxing protection, plus backup protection for uncleared external faults. Model variants cover two and three-winding transformers (including auto-transformers), with up to five sets of 3-phase CT inputs. Large CT counts are common in ring bus/mesh corner applications, where the P64 summates currents to create each total winding current, easing application of backup protection. Backup overcurrent can be directionalized, when the user includes the optional 3-phase VT input or 2-phase VT input in their chosen model.

In-built one-box control capabilities for up to eight controllable switchgear items are presented using a full color graphical HMI screen.

Key Features

- Universal IED for all transformer configurations
- Protection, control, monitoring, measurements and recording in one device
- Backup and logging of through faults
- Asset health monitoring – transformer Loss of Life estimation according to IEEE model
- Serial and Ethernet concurrent protocols, switchable by settings
- Advanced IEC 61850 Edition 2.1 implementation
- Advanced Cybersecurity including AAA, RADIUS, RBAC, and Syslog
- With fast start up time of less than 10s, resulting in protection, control and communications without the need to wait
- Programmable Scheme Logic (PSL) allows easy customization of the protection and control functions

Applications

- Transformer differential protection for 2 to 5 winding applications
- High stability during external faults with heavy CT saturation due to the transient bias
- No slow-down of the differential elements due to the 2nd harmonic in fault currents
- Adaptable to transformers with considerable CT mismatch between terminals – matching factor up to 20
- Current transformer supervision operates with or without voltage inputs, fast enough to prevent any spurious tripping and alarms

Protection & Control

- High-speed transformer differential protection
- Simple settings – wizard requires only nameplate data
- Novel CT saturation and no gap detection techniques enhances the low set differential element operating time
- Transient bias algorithm enhances relay stability and reduces CT requirements
- High and low impedance Restricted Earth Fault (REF) boosts trip sensitivity
- Patented CT supervision ensures no spurious trip for CT or wiring failures
- Integrated backup overcurrent per winding or CT input
- Fast reset (less than 1 cycle) circuit breaker failure element

Advanced Communications

- Redundant communications with zero downtime using PRP/HSR protocols
- RJ45 Ethernet engineering port
- Latest communication protocol implementation with IEEE 1588 precision time (PTP)

Cybersecurity

- Designed with an IEC 62443-4-1: 2018 certified Secure Development Lifecycle Process
- Provides the necessary capabilities to build an IEC 62443-3-3: 2013 compliant solution

One Box Concept

- Integrated full color display, for single-line diagram control of the protected bay
- Open, close, local/remote and direct function key access facilitate the control of connected switchgear – two circuit breakers plus eight other controllable plant items
- Select-before-operate, breaker health checks and interlocking capabilities



Application

The MiCOM Agile P642 is intended for two-winding transformer applications, with one set of 3-phase CTs per winding. The P643 covers up to 3 bias inputs (three CT sets) – either a three-winding application, or two-winding with dual CTs on one side. Where 4 or 5 feeding connections to the protected transformer exist, the P645 offers five bias input sets. All models have a single-phase VT input, mainly for overfluxing protection. An additional single phase VT input can be ordered in the P642 to provide voltage and directional functions to some extent.

The P643 and P645 allow an additional 3-phase VT input to be connected. This allows overcurrent backup to be directionalized, and expands the measurement and recording analog channels available. The P643 and P645 can be configured to protect transformers for differential protection and the unused CT inputs can be used to protect other circuits, or for overcurrent protection of auxiliary transformers.

As well as transformer protection, the P64x range may be applied to other unit applications, such as reactors and motors. The P64x series is supplied with a full suite of protection and control functions as standard.

The configuration column of the menu is used to control which functions the user requires in the intended application, and which may be disabled. Disabled functions are completely removed from the menu, to simplify settings.

Differential elements have an inbuilt configuration wizard to avoid settings errors.

To account for mismatches in CT ratio selection between terminals, matching factors of up to 20 allow proper compensation.

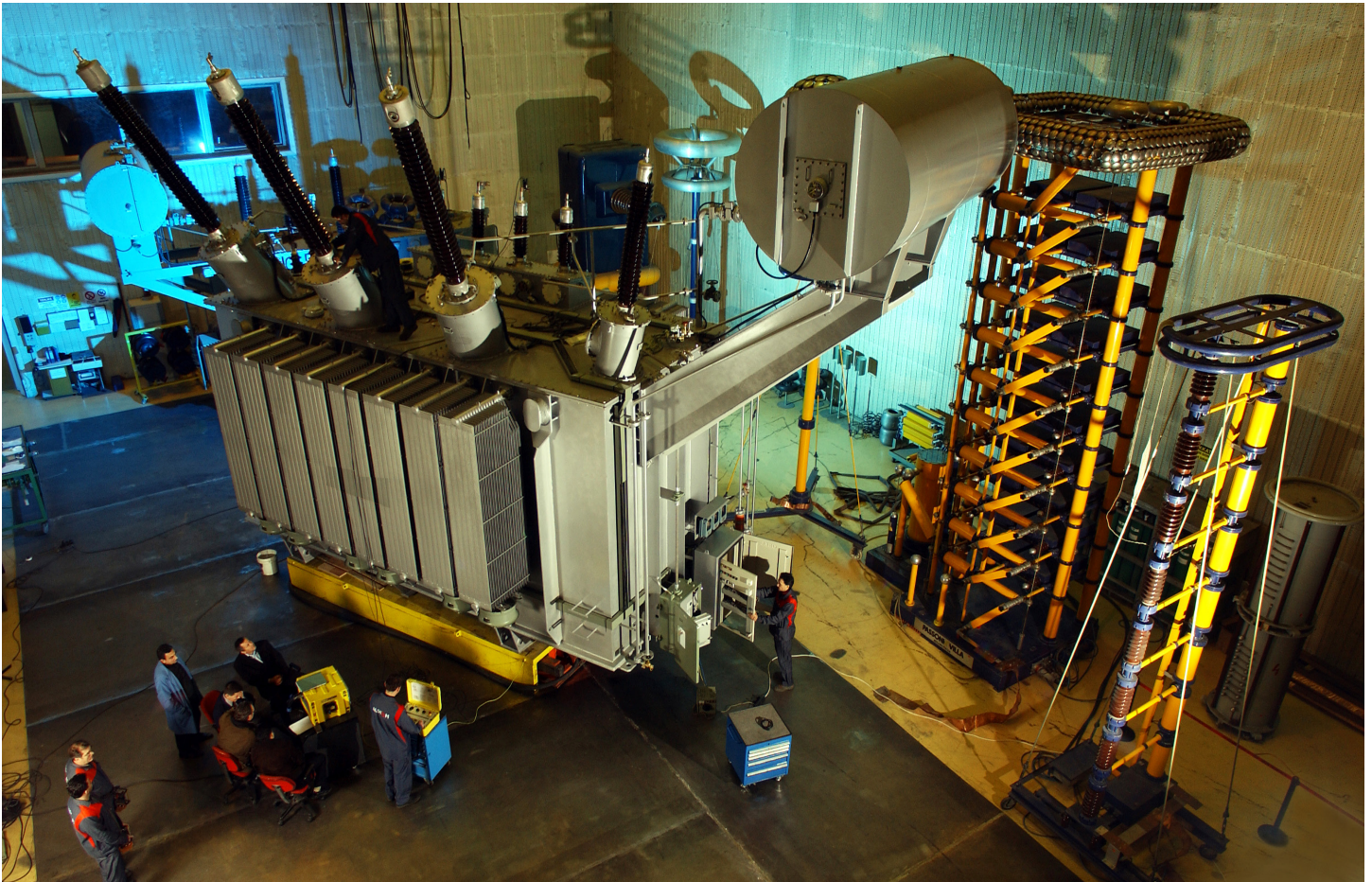

Functional Overview

ANSI	IEC 61850	FEATURES	P642	P643	P645
		Number of bias inputs (3-phase CT sets)	2	3	5
		Number of residual/star-point CTs	2	3	3
		Single-phase VT input	1	1	1
		Additional single-phase VT input	(•)		
		Additional 3-phase VT		(•)	(•)
87T	LzdPDFIF	Transformer differential protection	•	•	•
64	RefPDIF	High/Low impedance Restricted Earth Fault protection (windings)	2	3	3
49	ThmPTTR	Thermal overload	•	•	•
24	PVPH	V/Hz overfluxing	1	1(2)	1(2)
LoL		Loss of life	•	•	•
Thru		Through fault monitoring	•	•	•
RTD	RtfPTTR	RTDs x 10 PT100 temperature probes	(•)	(•)	(•)
CLIO	PTUC	Current loop transducer I/O (4 input / 4 output)	(•)	(•)	(•)
50/51	OcpPTOC	Four-stage overcurrent protection (element)	(2)	(4)	(4)
51V		One-two stage voltage controlled O/C element	(•)	(•)	(•)
51R		One-two stage voltage restrained O/C element	(•)	(•)	(•)
50N/51N	Ef_PTOC	Four stage derived or measured standby earth fault (element)	(2)	(4)	(4)
46	NgcPTOC	Three-four stage negative phase sequence O/C elements	•	•	•
67/67N	RDIR	Directionalised O/C, SBEF, and NPS elements (with optional 3 VT or 2 VT)	(•)	(•)	(•)
50BF	RBRF	Breaker fail protection (number of breakers)	2	3	5
27/59/59N	PTUV/PTOV	Undervoltage, overvoltage and residual VN> (with optional 3 VT addition)	-	(•)	(•)
47	NgvPTOV	Negative phase sequence over voltage	(•)	(•)	(•)
81U/81O	PTUF/PTOF	One-four stage underfrequency / one-two stage overfrequency	•	•	•
VTS		VT Supervision	(•)	(•)	(•)
CTS		Differential CTS (patented)	•	•	•
TCS		Trip circuit supervision	•	•	•
		32 user alarms	•	•	•
		CT input alarms	•	•	•
IRIG-B		IRIG-B time synchronizing input	(•)	(•)	(•)
	OptGGIO	Optocoupled logic inputs	8-32	16-48	16-48
	RlyGGIO	Relay output contacts	8-32	16-32	16-32
	FnkGGIO	Function keys	-	10	10
	LedGGIO	Programmable LEDs (R-red, G-green, Y-yellow)	13	23	23
PSL		Graphical programmable scheme logic	•	•	•
		Alternative setting groups	4	4	4
SOE		Sequence of event records	•	•	•
		Fault waveform disturbance records	•	•	•
		Redundant Ethernet Board	(•)	(•)	(•)

KEY: BRACKETS (•) DENOTE OPTIONAL FEATURES

Functional Overview

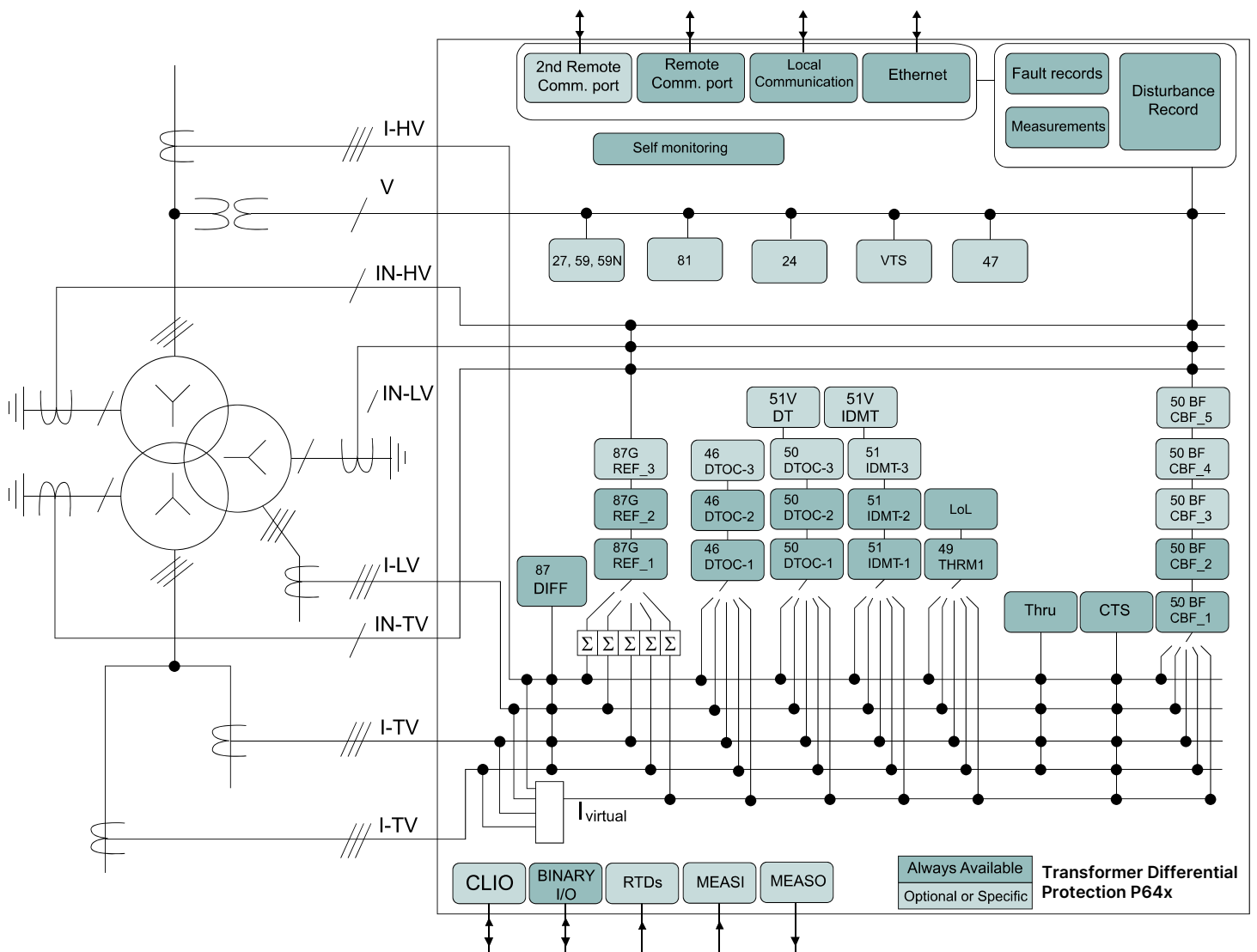

1. The three-phase VT input is optional.
2. The 27, 59, 59N and VTS functions require the three-phase VT input.
3. The frequency required by the 81 function is obtained from any analog signal but the voltage signals have priority over the current signals.

FIGURE 1: System Overview of the P64x series – example 3-winding, 4 bias application)

FAST, SENSITIVE PROTECTION FOR OUR CUSTOMERS' VALUABLE ASSETS

Main Protection

87T Transformer Differential

The algorithm has a triple slope percentage bias restraint, as shown in Figure 2. An internal fault will generate differential current. The bias current is that which merely flows through the protected unit, as a load or through-fed external fault. The initial characteristic is flat, for ease of commissioning, rising then to bias slope (k1). K1 is a low slope for sensitivity to faults whilst allowing for mismatch when the power transformer is at the limits of its tapchanger range, in addition to any current transformer ratio errors. At currents above rated, extra errors may be gradually introduced as a result of CT saturation, hence the bias slope increases to k2.

The P64x incorporates a transient bias characteristic that increases dynamically the operating current threshold during external faults, thus enhancing differential element stability and CT requirements. To improve the low set differential element operating times, the P64x has a CT saturation and no gap detection technique that prevents the second harmonic blocking from affecting the low set differential element. As a result, fast operating times are achieved during CT saturation and fault levels below high set one and two elements.

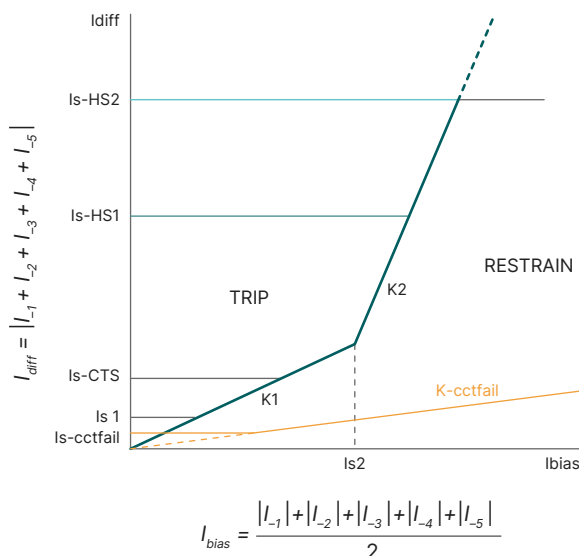

FIGURE 2: Biased differential protection (87T)

The CT saturation and no gap detection distinguish between magnetising inrush and saturated current waveforms. An external fault detection technique has been included to prevent the CT saturation and no gap detection from affecting the second harmonic blocking during external faults, thus maintaining stability.

Energization of a transformer causes magnetising inrush current to flow in one winding only and the differential elements may need stabilising whilst the inrush persists (see Figure 3). A proven second harmonic current ratio scheme is used. The differential protection may also be restrained when the transformer is overfluxed so that an instantaneous trip is not issued for transient overfluxing. Overfluxing restraint is conditioned by the percentage of fifth harmonic current present. Two high set instantaneous differential elements, not subject to harmonic restraint, are provided to ensure rapid clearance of high current faults.

The differential protection setting configuration utility requires only known data – that which resides on the transformer rating plate, the CT rating plate and information on any in-zone earthing transformer.

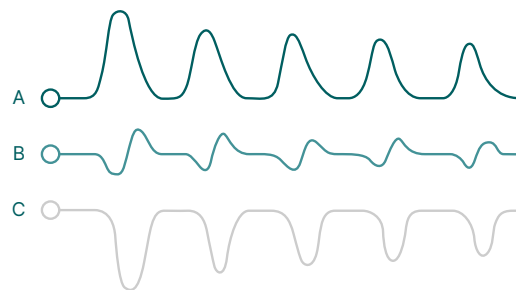

FIGURE 3: Typical magnetizing inrush waveform – showing harmonic distortion

REF: Restricted Earth (Ground) Fault

Restricted earth fault protection is included to cover a larger percentage of the transformer windings than might be possible with the main differential elements. A separate element per winding is provided (P642: HV and LV).

(P643/P645: HV, LV, and if required, the TV tertiary too). Low impedance and high impedance REF for conventional transformers and autotransformers are available.

Figure 4 shows a typical restricted earth fault application. Biased REF is used, to avoid the need for any stabilising resistor or varistor/ Metrosil. REF elements operate independently of inrush detection, potentially offering faster tripping for low or moderate fault currents, in addition to enhanced sensitivity. Low impedance REF element stability is enhanced by a transient bias algorithm.

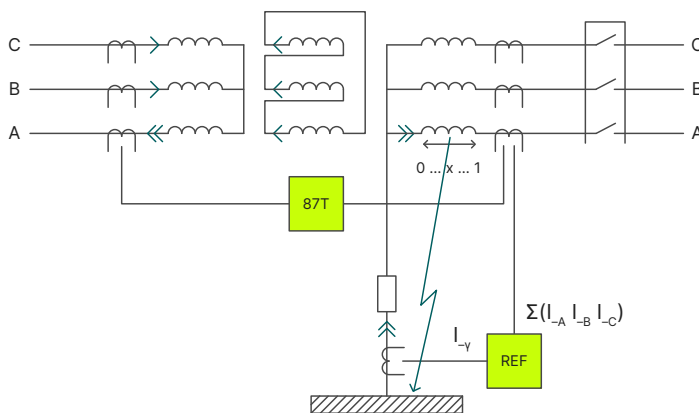

FIGURE 4: Restricted earth fault application

Thermal Overload

All models offer thermal overload protection based on the IEEE Standard C57.91-1995, with the extent of protection being the choice of the customer. The most simple application employs an I²t characteristic. Time constants are set, such that the thermal model can follow the correct exponential heating and cooling profile, replicating the winding hotspot temperature. Four cooling modes are available, and the oil exponent and winding exponent can be set independently for each mode. Alarm and trip thresholds are available as outputs.

To enhance the thermal replica, ambient and/or top-oil temperature compensation may be applied. This is achieved by fitting the RTD board option, and positioning the PT100 probes appropriately (outdoors, or within the transformer tank). Additionally, alarm and trip setpoints can be applied for any probe input, should an absolute measured temperature at the probe location be of interest. Ten independent probe inputs are available, making radiator pump and fan control an additional possibility using the relay's programmable scheme logic (PSL).

Thermal overload protection is a closely related companion function to the Loss of Life monitoring feature described later.

V/Hz Overfluxing Protection

The single-phase voltage input may be connected ph-ph or ph-neutral and is provided to enable overfluxing detection. Alarm and tripping characteristics, which are based on a measurement of the voltage/frequency ratio, are provided.

The alarm is definite time delayed whilst the trip characteristic may be applied with up to four definite time (DT) elements, or an IDMT curve plus up to three DT elements.

The optional additional 3-phase VT input available in the P643 and P645 allows overfluxing to be applied on both HV and LV sides of the transformer, to ensure optimum protection, irrespective of the loadflow direction. Both thermal overload and overfluxing elements are essentially thermal based, modelling winding and oil heating, or heating of core bolts and laminations. Due to time constants being in minutes (rather than seconds), heating and cooling of both replicas can be relatively slow.

A pre-trip countdown is provided, displaying the time remaining to trip if the present level of load, or flux were to be maintained. A pre-trip alarm can be applied, notifying the dispatcher that he/she has a certain number of minutes for remedial action, before a trip is likely. After any injection testing, all replicas can be forced to reset via a user command.

Circuit Breaker Failure

The breaker failure protection may be initiated from internal or external protection within the P64x, and also from external devices. In the case of Buchholz (sudden pressure) relays, the CBF elements for all breakers must be initiated in parallel. Where external feeder or busbar protection is applied to trip only one (or more) breaker(s), the P64x has the ability to initiate the CBF scheme on a per breaker basis. Retripping and backtripping schemes are supported, all with a fast reset. A zero crossing detection algorithm has been implemented to allow fast reset of the CBF element considering subsidence current. The CBF element resets in less than 1 cycle. Independent settings per circuit breaker have been implemented.

A neutral earth fault undercurrent element is available per circuit breaker, and it can be set as either measured or derived. A maximum of three single phase CT inputs are available to be used by the CBF.

Supervisory Functions

Voltage transformer supervision is provided to detect loss of one, two or three VT signals (P643 and P645 models fitted with a 3-phase VT and P642 fitted with 2 single phase VT inputs). Current transformer supervision is provided to detect loss of phase CT input signals. Using the "differential CTS" feature (patented), the relay performs an intelligent comparison of the negative sequence current imbalance at all CT terminals, to determine which, if any, CTs have failed. This comparison detects all CT shorts, open circuits, and wiring disconnections without an inherent time delay. Operation of the differential protection can be restraint during the failure to avoid an unwanted trip. The CTS thus assures realtime stability of the differential elements, and any applicable REF protection.

Back-up Protection

The P642, P643, and P645 are delivered with comprehensive back-up protection. Typically this will be used in time-delayed mode to improve fault detection dependability for system (out-of-zone) faults. System integrity can also be improved, utilising internal elements for load-shedding, interlocking, alarm, or other purposes.

Current-Based Protection

Each winding, whether the current is directly measured from one CT input, or is a virtual summation from two CTs, has the following elements available:

- Phase fault overcurrent
- Negative sequence overcurrent
- Earth (ground) fault

2nd Harmonic Blocking

The 2nd harmonic blocking detects high inrush current inflows that occur when transformers or machines are connected. The function will block the phase overcurrent, earth fault and REF.

Up to four stages of each element, per winding, are available – with a choice of standard IEC and ANSI/IEEE IDMT curves, instantaneous, and definite time operation. Where a P643/P645 has the 3-phase VT or a P642 has the 2 single phase VTs, any of the current protection applied on the same winding as the VT location may be directionalised. Overcurrent elements, directionalised if necessary, can be useful to clear reverse-fed upstream faults, or for protection of adjacent busbars. At distribution and industrial voltage levels, low-cost bus protection schemes can be configured using the "reverse interlocking" principle. This is a logic-based scheme, which will trip should a fault current flow onto the busbar not be accompanied by an external fault start on an outgoing circuit.

The earth fault protection is configurable to operate either in measured, or derived mode. "Measured" denotes that the winding (or external earthing transformer) has a star-point single phase CT available in the Y-ground connection, and the user wishes this current to be used to implement standby earth fault (SBEF). "Derived" is set for delta windings, or other cases where the user prefers to use the calculated residual current from the 3-phase CTs.

Voltage Protection*

Two stages each are available for phase overvoltage and phase undervoltage in the P643/5 when the 3-phase VT is ordered. One stage is available for negative phase sequence overvoltage when the 3-phase VT is ordered (P643/5) or the 2 single phase VTs is ordered (P642). Residual overvoltage (neutral displacement) is also available when the 3 phase VT is ordered (P643/5). Such elements are particularly useful to detect voltage regulation errors and earth faults.

Voltage Dependent Overcurrent Protection*

In order to provide backup phase fault protection for generator-transformers or to provide more sensitive overcurrent protection for close up faults, a voltage dependent overcurrent element (either controlled or restrained) is included. Two definite time or IDMT stages are available.

** Available when optional 3-phase VT input is ordered in P643 or P645 and 2 single phase VT inputs is ordered in P642*

Frequency Protection

Four stages of underfrequency and two stages of overfrequency are provided, permitting load shedding and restoration schemes to be implemented. The frequency protection may consider any analogue signal, having the voltage signal as the preference.

Control and Logic

User Interface

Ten function keys in 60 and 80TE case sizes operate in two modes, normal and toggled, with integrated tricolour programmable LEDs. These replace traditional hardwired control scheme switches and annunciation, saving on engineering time and wiring costs. Thirteen further tricolour LEDs are available, freely-configurable, in addition to five fixed-function LEDs

In addition to support of English, French, German, Spanish, Italian, Portuguese and Polish languages, the ability to customise the menu text and alarm descriptions is available. Easily switch between English and an additional language on the local display without uploading new firmware.

A USB front port offers ready access by field personnel's laptop computers.

One-Box Switchgear Control

Circuit-breaker control is available from the front panel user interface, optically isolated inputs and remotely via the substation communications. 8 sets of switch control logic, LN CSWI/XSWI for controlling/monitoring of disconnectors and earth switches are also available. Operation of the bay is greatly assisted using the colour graphical HMI, open/close buttons and local/remote control mode switching.

Programmable Scheme Logic (PSL)

Powerful graphical logic allows the user to customize the protection and control functions. The logic includes 32 timers, 32 counters, 512 gates (OR, AND, MAJORITY) and set/reset latch functions, with the ability to invert the inputs and outputs and provide feedback. Each gate can support a large array of inputs, with a simple right-click of inputs or outputs serving to invert the signal. Output contacts have optional latching (lockout) functionality.

The PSL can be used to implement trip circuit supervision or implement complex logic such as frequency restoration schemes. Schemes are developed capable of supervising the trip coil and circuit with the circuit breaker open or closed, achieving full 'H7' performance.

GE Vernova's MiCOM Agile is deterministic – intensive logic and multiple nested gates do not affect the speed of protection tripping, I/O processing, measured or sampled values acquisition nor GOOSE response. The logic gates are processed concurrently, such that logic 'race' scenarios are eliminated. All aspects of MiCOM P40 IED configuration are managed using the S1 Agile software. The software is license-free, and able to support interfacing with .xrio and CAPE simulation environments, and easy Excel import/export where required.

Binary Inputs and Outputs

Opto-isolated binary inputs comply to the ESI 48-4 EB2 standard and are immune to inductive fields created in substations where wiring runs for hundreds of metres in the yard and neighboring wires, busbars and power conductors create strong fields. The inputs support programmable pickup with no spurious pickup during battery ground faults or capacitive discharges, thereby making them perfect for plant status monitoring.

Each output relay module provides normally-open (form A) and a generous mix of changeover (form C) contacts. Optional high-speed/high-break contacts are available, with 30A high break rupturing ensuring no burn-out of contacts during normal operations or situations such as breaker failure or defective CB auxiliary contacts.

Measurement and Recording

Multiple measured analog quantities, with phase angles, are provided. These include:

- Phase and neutral currents for all windings, plus sequence components and 2nd harmonic component magnitudes
- Measurements of all voltage inputs
- Frequency, power factor, Watts and VARs
- Maximum demand and rolling values
- Bias currents, differential currents
- All thermal states, temperatures, and loss-of-life
- Measurements can be assigned to CLIO

Post-Fault Analysis

Event Records (SOE)

Up to 5000 time-tagged event records can be stored.

Fault Records

The last 100 fault records are stored as minimum.

Disturbance Records

The oscillography has 16 analogue channels, 128 digitals and 1 time channel, all at a high resolution of 48 samples/ cycle. With 1050s of recording capability, ability to store 100 waveforms of maximum duration of upto 10.5 second duration can be stored.

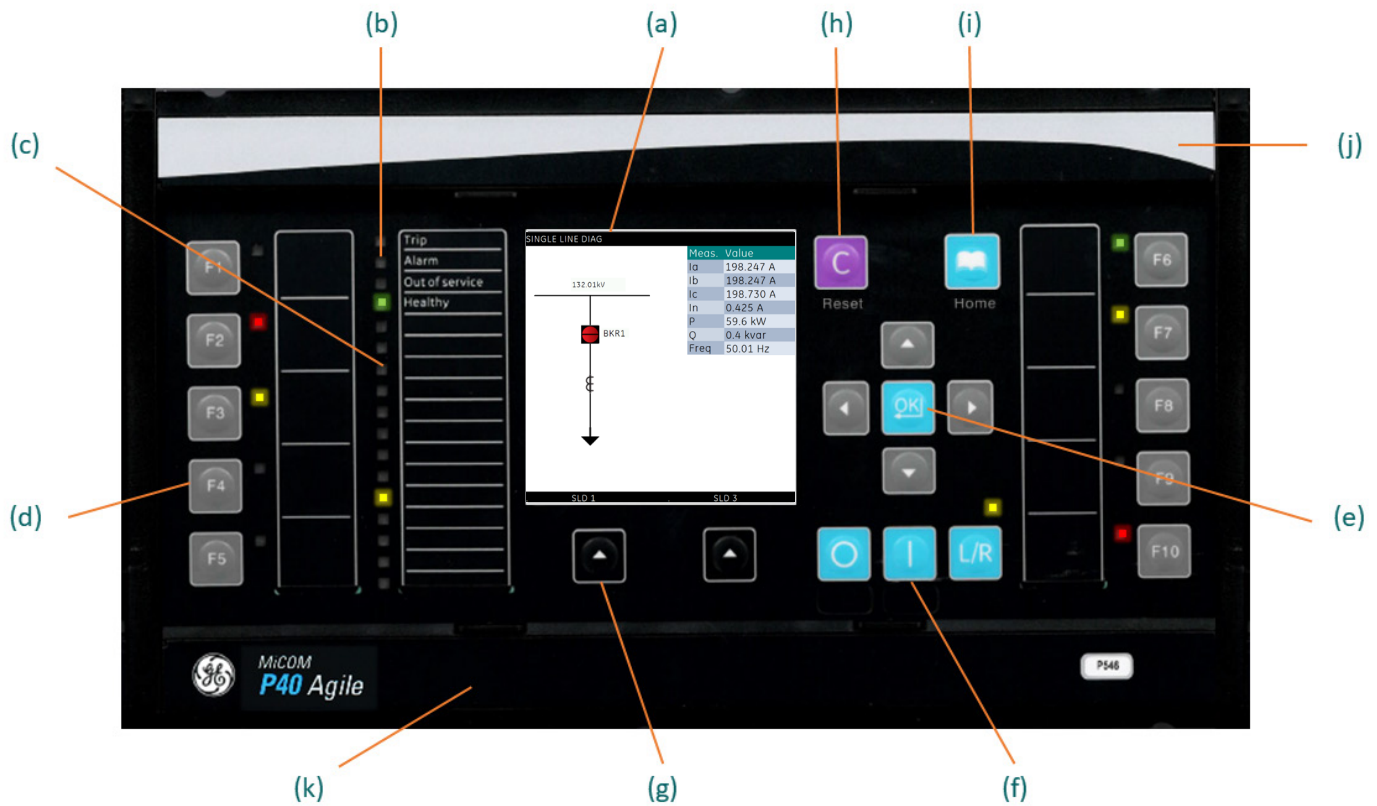

Figure 4: Front fascia view

- a. Colour Screen
- b. Four Fixed-Function LEDs
- c. 13 Tricolour Programmable LEDs
- d. Ten Function Keys with Tricolour LEDs
- e. Menu Navigation and Data Entry
- f. Bay Control and Local/Remote with LED
- g. Context-Sensitive Keys
- h. Clear Key – Long Press to Reset
- i. Read Key – Long Press to Return to Home Screen
- j. Top Flap Conceals CORTEC and Rating Labels
- k. Bottom Flap Conceals USB(B) Access Port

Ordering Information

CORTEC Order Code Matrix		1-3	4	5	6	7	8	9	10	11	12-14	15
Transformer Protection		P64									AB	
2 End: 2 Winding Transformer		2										
3 End: 3 Winding Transformer		3										
5 End: 3 Winding Transformer		5										
Nominal Auxiliary Supply Voltage												
24-54 Vdc		7										
48-125 Vdc (40-100 Vac)		8										
110-250 Vdc (100-240 Vac)		9										
CT and VT Ratings		CT/Hardware Opt. Compatibility										
HV-LV In = 1A/5A, Vn = (100/120V) (xCT/1VT) Standard CT		P642 = 8, P643 = 12, P645 = 18		1								
HV-LV In = 1A/5A, Vn = (100/120V) (xCT/4VT) Standard CT (8 CT & 2VT for P642)		P642 = 8, P643 = 12, P645 = 18		2								
HV-LV In = 1A/5A, Vn = (100/120V) (xCT/1VT) Sensitive CT (P643/5 Only)		P643 = 12, P645 = 18		3								
HV-LV In = 1A/5A, Vn = (100/120V) (xCT/4VT) Sensitive CT (P643/5 Only)		P643 = 12, P645 = 18		4								
Hardware Options												
Standard - 1 x RS485 rear serial communications port provided with all ordering options (Courier, -103, DNP3 ready)						1						
With additional IRIG-B (Modulated)						2						
With additional IRIG-B (Modulated) & Serial Fibre Optic comms						4						
Single Ethernet 1 LC Duplex port + Universal IRIG-B + 1588 + 1 RJ45 Maintenance Port						U						
Redundant Ethernet PRP/HSR/RSTP/Failover 2 LC Duplex port + IEC870-103 Serial Fibre ST ports + Universal IRIG-B + 1588 + 1 RJ45 Maintenance Port						V						
Redundant Ethernet PRP/HSR/RSTP/Failover 2 RJ45 + Universal IRIG-B + 1588 + 1 RJ45 Maintenance Port						W						
Redundant Ethernet PRP/HSR/RSTP/Failover 2 LC Duplex ports + Universal IRIG-B + 1588 + 1 RJ45 Maintenance Port						Y						
Input/Output Options		Case Size Compatibility										
8 inputs, 8 outputs		40TE, 60TE						B				
12 inputs, 12 outputs		60TE						E				
16 inputs, 16 outputs		60TE						H				
16 inputs, 16 outputs + 4 High-Speed High-Break		60TE, 80TE						J				
16 inputs, 21 outputs		60TE, 80TE						K				
16 inputs, 24 outputs		60TE, 80TE						L				
20 inputs, 20 outputs		60TE, 80TE						P				
24 inputs, 16 outputs		60TE, 80TE						S				
24 inputs, 16 outputs + 8 High-Speed High-Break		80TE						T				
24 inputs, 24 outputs		80TE						U				
24 inputs, 32 outputs		80TE						V				
32 inputs, 24 outputs		80TE						1				
32 inputs, 32 outputs		80TE						2				
40 inputs, 24 outputs		80TE						4				
48 inputs, 16 outputs		80TE						7				
Product Specific Options												
RTD								A				
CLIO								B				
RTD + CLIO								C				
None								X				
Case Size and Mounting		Product Compatibility										
80TE Case - Flush/Panel Mounting with Harsh Env. Coating, with USB Port and 10 Function Keys		P642, P643, P645						S				
80TE Case - 19" Rack Mounting with Harsh Env. Coating, with USB Port and 10 Function Keys		P642, P643, P645						T				
40TE Case - Flush/Panel Mounting with Harsh Env. Coating, with USB Port, without Function Keys		P642						U				
60TE Case - Flush/Panel Mounting with Harsh Env. Coating, with USB Port and 10 Function Keys		P642, P643						V				
Product Features												
Standard Version									X			
Software Version												
Enhanced cybersecurity, concurrent protocols, 5000 events, 100 fault records, 1050s oscillography											AB	
Customer-Specific Additions												
Standard version											0	
Customer-specific configuration/options											A	
Hardware Version												
5th Generation Hardware, Graphical Colour HMI with High Performance Processing												Q

Plant Supervision

Trip Circuit Supervision

Supervision of the trip circuit can be implemented using optocoupled inputs and the programmable scheme logic.

Analog (Current Loop) Inputs and Outputs (CLIO)

Four inputs are provided for transducers with ranges of 0-1 mA, 0-10 mA, 0-20 mA or 4-20 mA. Associated with each input there are two time delayed protection stages, one for alarm and one for trip. Each stage can be set for 'Over' or 'Under' operation.

Communications with Remote Operators and Substation Automation

The following protocols are available:

- Courier/K-Bus
- IEC 60870-5-103
- DNP 3.0 (EAI-485 serial)
- IEC 61850 Edition 2.1 station bus
- SNTP time synchronization
- IRIG-B time synch, modulated or demodulated
- RSTP, or PRP and HSR as per IEC 62439-3
- SNMP v2c and v3
- USB front-port communication

P64x devices can be enhanced with an optional redundant Ethernet board. The redundancy is managed by the market's fastest recovery time protocols: IEC 62439-3 PRP and HSR allowing bumpless redundancy and RSTP, offering multi-vendor interoperability.

The Ethernet boards include a dedicated RJ45 engineering port, typically for engineering access by protection engineers/ operators when the main Ethernet ports are reserved for SCADA traffic.

In order to help smooth transition from the existing protocol to IEC 61850, the P64 relay has been designed to provide Courier, -103 or DNP3 on the RS485 port, while providing IEC 61850 on the Ethernet port(s). This allows customers to future-proof their investment, getting ready for any future SCADA/DCS upgrade.

Second Rear Serial Port

An additional second rear Courier port can be ordered as an option, designed typically for engineering access by protection engineers/ operators when the main port is reserved for SCADA traffic.

Asset Life Extension

In addition to new-build, GE Vernova's 5th generation MiCOM relays can be used to refurbish time-served protection schemes. As the P64 is pin-pin compatible with forerunner P642, P643 and P645 relays from Alstom, AREVA and GE Vernova, they can be interchanged in minutes for an easy upgrade. This dramatically reduces the retrofit time and cost.



Environmental Responsibility

The Relays are manufactured in a lead-free soldering process using leadfree components. Power dissipation is low, for smaller station batteries and to reduce the global warming potential (GWP) during the installed life.

GE Vernova-branded MiCOM P64x relays have no resident battery, to ease airfreight logistics and dispense with a maintenance item.

Cybersecurity

The sophistication of protection schemes, coupled with the advancement of technology, increasingly leads to devices and substations being networked. This introduces a potential security risk making the grid vulnerable to cyber-attack. To secure communication within such environments, MiCOM Agile P64 offers NERC®-compliant cybersecurity.

All of GE Vernova's MiCOM range is manufactured in ISO 27001 certified factories.

Quality Built-In (QBi)

Parts stress analysis in R&D, rigorous component supplier selection, and a shipping carton compliant with ISTA protection requirements all are examples of best-practice to maximize long-life reliability. All circuit boards have harsh environmental coating, to resist moisture, salt, corrosive atmosphere and industrial ambient pollution – as standard. The relay's case offers full encapsulation, with no ventilation holes for dust ingress. Circuit board production uses in-circuit tests, boundary scanning, built-in self test, automated optical inspection, and X-ray scanning to achieve maximum test coverage.

In addition to the standard -25°C to +55°C operating temperatures claim as per IEC 60255-6, the P64 range has proven withstand capability at extremes of temperature as per IEC 60068-2. These onerous tests were passed at -40°C and +85°C for 96 continuous hours in each case. All MiCOM models offer power-up diagnostics and continuous self monitoring for high availability.

Case Parameters

CASE TYPES 40 TE / 60 TE / 80 TE

Weight (40TE case) 7 kg - 8 kg*

Weight (60TE case) 9 kg - 12 kg*

Weight (80TE case) 13 kg - 16 kg*

Dimensions in (40TE case) W: 206.0 mm H: 177.0 mm D: 243.1 mm

Dimensions in (60TE case) W: 309.6 mm H: 177.0 mm D: 243.1 mm

Dimensions in (80TE case) W: 413.2 mm H: 177.0 mm D: 243.1 mm

Mounting Panel, rack or retrofit *Depending on chosen options

For more information visit [GEGridSolutions.com](https://www.gesolutions.com)

IEC is a registered trademark of Commission Electrotechnique Internationale. IEEE is a registered trademark of the Institute of Electrical Electronics Engineers, Inc. Modbus is a registered trademark of Schneider Automation. NERC is a registered trademark of North American Electric Reliability Council. NIST is a registered trademark of the National Institute of Standards and Technology. ABB Thomas & Bets is a registered trademark of ABB Installation Products Ltd. Cooper Nova is a registered trademark of Eaton Corporation. All other trademarks, images and graphics are property of their respective owners.

GE, the GE monogram, Multilin, FlexLogic, EnerVista and CyberSentry are trademarks of General Electric Company. GE reserves the right to make changes to specifications of products described at any time without notice and without obligation to notify any person of such changes.

© 2025 GE Vernova and/or its affiliates. All rights reserved.

GEA35502
English