

KOTEF

Combined CT/VT
72.5 to 420 kV

The KOTEF is designed to provide both current and voltage measurements from a single device.

Design and advantages

As with separate transformers, the current transformer part is located in the head housing and the voltage transformer part in the base tank. The grading layers between high-voltage potential and ground potential are arranged in opposite directions inside the insulator. The base dimensions remain the same as a current or voltage transformer of the same nominal voltage.

The CT and VT functions are fulfilled within a single unit. It utilises the same components as the individual CTs and VTs. Both transformers are combined in a single metering insulator and are available in porcelain or composite. This is an excellent solution for adding metering capability to either a new substation installation or a site being upgraded where space is at a premium. Consequently, considerable cost savings are realized in the initial purchase price, transportation, real estate and installation labor and materials compared to the equivalent costs of two separate transformers.

Long Service Life and Near Zero Maintenance

Insulation integrity is assured by the fact that the oil is hermetically sealed from the atmosphere by a metallic diaphragm assembly. All external parts are of corrosion-resistant material. Therefore, regular painting is not required.

KOTEF have been designed for a 30 year lifetime and, thanks to the soundness of our technical concepts, many will outlive this service life.



Main Features

- Metering – Protection
- Characteristics:
 - High quality paper-oil insulation
 - Oil expansion by stainless steel diaphragm bellows
 - Oil level indicator
 - Secondary cores in aluminum box
 - Changing of primary ratio by primary series-parallel connection double or triple ratio) or by secondary taps
- Earthquake-proof design: The standard KOTEF resists medium intensity seismic events. For highly active seismic regions, the design is adapted accordingly.
- Compliance with IEC, IEEE or other equivalent standards

Customer Benefits

- Price advantage
- Saving on space: only one base
- Cost savings on transportation and assembly
- Near zero maintenance
- Protection against bursting



A full range of global expertise to meet your specific and exacting challenges

Current Transformer Design

Top core design, with active parts in the head. The primary is normally a straight bar type conductor. Ratio change can be accomplished either by primary series-parallel connection (double or triple ratio) or by secondary taps. Combinations of series-parallel connection and secondary taps are also possible. This maintains the output and accuracy of the secondaries at all ratios. The head type design also has the advantage of spreading the primary winding uniformly and symmetrically around the cores, avoiding local saturation and reducing the leakage flux.

Current transformers can have several toroidal laminated cores which are independent of each other. Cores with secondary windings are accommodated in a thick-walled, round core protection made of aluminium.

Core protection housing is connected to a strong metal pipe inside the insulator which leads to the base plate. Cross sections and connections have been dimensioned in such way that the current can be led to ground in the event of a short circuit, without a secondary arc occurring in the area of insulator.

Voltage Transformer Design

Primary winding

During primary winding the double-enameled copper wire is continuously monitored by an electronic detector seeking faults in the insulating system.

Neutral end

The end of the primary winding is led into terminal box. It is insulated against ground to withstand a power frequency test with 3 kV (1 min.) or 19 kV (1 min.) according to ANSI standards.

Windings and ratings

One or two secondary windings can be provided for metering and protection purposes. An optional separate winding can be supplied for ground fault detection. A double ratio is achieved by a secondary tap. All IEC or ANSI accuracy classes for metering and protection purposes can be provided.

Thermal burden

Typical thermal burden rating is 2,000 to 4,000 VA.

Voltage factor

All standard voltage factor scan be provided, i.e. from 1.5 UN for thirty second to 1.9 UN for eight hours.

Rated Currents

The maximum primary rated current is 5,000 A. Secondary rated currents are 1 A or 5 A.

Alteration to the Actual Transformation Ratio

- Primary reconnection at the ratio of 1:2 (max. 4800 A)
 - Series connection up to 2,400 A
 - Parallel connection up to 4,800 A
- Primary reconnection at the ratio of 1:2:4 (max. 3,600 A)
 - Series connection up to 900 A
 - Series and parallel up to 1,800 A
 - Parallel connection up to 3,600 A
- Secondary taps available for smaller nominal currents

Combinations of the primary reconnection and the secondary taps are possible.

Thermal and Dynamic Rating

An advantage of the head design is that the primary current takes the shortest path through the CT portion. As a result, a high thermal and dynamic short-circuit capability is achieved: 80 kA for one second, dynamic current of 200 kA.

Components

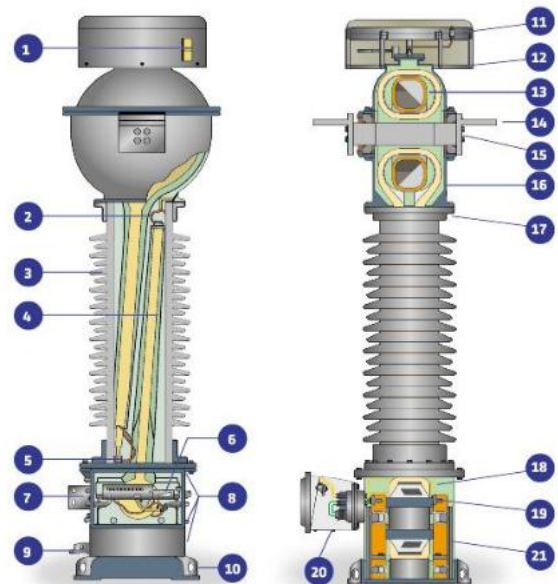

- | | |
|---|---|
| 1. Oil level indicator | 11. Stainless steel oil expansion chamber |
| 2. Potential connection | 12. Aluminium flange and cover |
| 3. Porcelain insulator | 13. CT core |
| 4. Capacitive graded bushing | 14. Primary terminal |
| 5. Ground connection | 15. Primary conductor |
| 6. Secondary terminals | 16. Core housing |
| 7. Ground pad | 17. Hotdip galvanized gray iron flange |
| 8. Aluminium bases tank, cover plate and terminal box | 18. VT high voltage winding |
| 9. Oil sampling valve | 19. VT low voltage winding |
| 10. Lifting eye (4 x) | 20. Access plate |
| | 21. Laminated core |



High Quality Insulation

Insulating paper is applied for the most part by special machines which ensure uniform precision application and high density. An extremely low residual humidity is attained by a special drying process.

Grading layers with well-rounded edges uniformly distribute the field over the whole unit.

Hermetically Sealed

The KOTEF maintains a completely sealed and pressure free system through the use of a stainless steel metallic diaphragm assembly. The diaphragm assembly provides oil expansion and pressure compensation, protects the interior from air and moisture and preserves the dielectric strength of the CV-VT. The movements of the compensation system are registered by an oil level indicator which is visible behind a window fitted in the transformer head.

Leakproof design

The head housing is made of corrosion-proof aluminum alloy. Every housing is subjected to a vacuum leak test by helium leak detection. An overall leak test is performed on every completely assembled unit before oil fitting.

Primary terminals

Standardized primary terminals consist of flat aluminium terminal pads with 4, 6, 8, or more holes for constant currents up to 5,000 A. On request, single or double round terminals made of nickel-plated copper can be provided.

Secondary terminal box

The terminal box is very spacious and has a removable plate located at the bottom which allows for in-factory or on-site drilling of the conduit entrances for the insertion of cable glands as desired.

Insulator

The outer insulation consists of high-quality oxide porcelain in brown (RAL 8016) or grey (ANSI 70). Standard creepage distances are available according to the dimension tables.

Larger creepage distances and composite insulators are available on request.

Protection Against Bursting

The optimised insulation structure and appropriate structural measures secure the high-grade dielectric for a very long time. The following additional measures are taken to prevent the porcelain from bursting in the event of an inner insulation breakdown, e.g. in case of lightning strikes:

- The active parts of the current transformer are positioned in aluminum housings above the common porcelain insulator while the voltage transformer active parts are below it
- Internal fault current connections are led through the porcelain
- A fusing element between the secondary bushings and secondary terminal is optionally available to protect the unit when incorrectly operated with short-circuited secondary terminals
- A pressure relief plates exists in the expansion body area on the head
- Upon request, a composite insulator consisting of fiberglass reinforced pipe and silicone rubber screens can be provided instead of the porcelain insulator

Testing

Testing is in conformance with national and international standards. When performing the power-frequency test, the dielectric loss angle and the internal partial discharge level are measured as a routine test. Tests reports are provided with each unit.

Additional Information

Dielectric loss factor

Tan δ smaller than 0.005 up to the power-frequency test voltage

Radio Influence Voltage (RIV)

Less than 2500 μ V at 1.1 Um

Internal partial discharge

Less than 10 pC at 1.0 Um

Frequency

50 Hz or 60 Hz or 16 2/3 Hz. Other values on request

Ambient temperature

-30 °C ... +35 °C on a 24h average. Other designs can be provided upon request for temperatures ranges falling outside of the mentioned range, i.e. -50 °C to +50 °C

Mechanical strength

According to IEC 60044-1

Dimensions

The following dimensions refer to standard versions. Other Um values effectuate other dimensions. The base tank size can vary based on greater voltage transformer output requirements and/or frequencies smaller than 50 Hz.

The head size of the CT portion depends on the ratings of the cores, the primary current and the thermal short-time current. Other head sizes and longer creepage distances can be provided.

Dimensions

TYPE		KOTEF 72.5		KOTEF 123		KOTEF 145		KOTEF 170	KOTEF 245	
Head Size		1	3A	1	3A	1	3A	3A	4	
Maximum system voltage (Um)	kV	72.5	72.5	123	123	145	145	170	245	
Impulse test voltage (BIL)	kV	350	350	550	550	650	650	750	1050	
Minimum creepage distance	mm	1620	1620	2575	2575	2890	2890	3870	5150	
		mm	mm	mm	mm	mm	mm	mm	mm	
Dimensions		A	2,111	2,222	2,471	2,582	2,702	2,813	3,433	4,330
1:1		B ₁	1,678	1,726	2,038	2,086	2,269	2,317	2,797	3,419
1:1 and 1:2:4		(B ₂)	1,821	1,869	2,181	2,229	2,412	2,460	2,940	3,562
		C	630	630	990	990	1,110	1,110	1,500	2,000
		D	629	629	629	629	740	740	770	790
		E1	742	900	742	900	742	900	900	935
		(E ₂)	772	900	772	930	772	930	930	965
		F	450	450	450	450	450	450	450	600
Total weight (approx.)	kg	465	618	517	670	591	744	952	1,527	
Weight of oil (approx.)	kg	94	140	101	147	145	191	264	479	

Indicatives values only - All indicated dimensions must be confirmed with order. Other values on request.

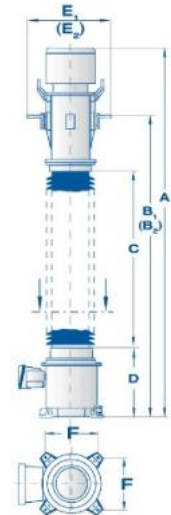

Dimensions

TYPE		KOTEF 362	KOTEF 420
Head size		5	5
Maximum system voltage (Um)	kV	362	420
Impulse test voltage (BIL)	kV	1,300	1,425
Minimum creepage distance	mm	8,400	8,400
		mm	mm
Dimensions		A	6,910
1:1		B ₁	5,369.5
1:1 and 1:2:4		(B ₂)	5,512
		C	3,400
		D	1,210
		E1	1,075
		(E ₂)	1,105
		F	900
Total weight (approx.)	kg	2323	2323
Weight of oil (approx.)	kg	893	893

Indicatives values only - All indicated dimensions must be confirmed with order. Other values on request.

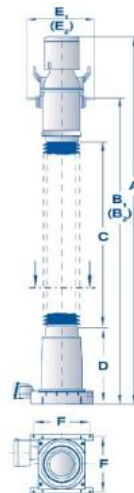

For more information please contact
GE
Grid Solutions

Worldwide Contact Center

Web: www.GEGridSolutions.com/contact
Phone: +44 (0) 1785 250 070

GEGridSolutions.com

IEC is a registered trademark of Commission Electrotechnique Internationale. IEEE is a registered trademark of the Institute of Electrical Electronics Engineers, Inc.

GE and the GE monogram are trademarks of General Electric Company.

GE reserves the right to make changes to specifications of products described at any time without notice and without obligation to notify any person of such changes.

KOTEF_IEC-Brochure-EN-2020-03-Grid-AIS-0035. Copyright 2020, General Electric Company. All rights reserved.



Imagination at work