

# MANAGING TRANSMISSION VOLTAGES IN POWER SYSTEMS WITH **AIR CORE SHUNT REACTORS**

## Authored by:

Ricardo Carvalho Campos, Sales & Proposal Director

André Lanza de Oliveira e Silva, Product Sales Specialist

Marcelo Ricardo de Moraes, Engineering and R&D Manager

Jari Kotiniitty, Senior R&D Manager

Tommi Keikko, ACR Expert



GE VERNOVA

## Introduction

During normal conditions, the operating voltages of transmission and distribution systems must be maintained within very tight limits, typically between 0.95 and 1.05 p.u. of the rated value. At low system loading, operating voltages increase due to the capacitive nature of the grid. Shunt reactors are then used to absorb this excess reactive power generated by the grid's capacitances and thereby regulate the operating voltages of transmission and distribution systems.

This document presents useful information on the application and specification of shunt reactors for transmission and distribution power systems, describing how voltage control is achieved. It also provides a brief explanation of the design aspects and benefits of using dry type air core shunt reactors, including switching, protection, and grounding.

## Benefits of Dry Type Air Core Shunt Reactors

Dry type air core shunt reactors are a very cost-effective solution for reactive power compensation of transmission and distribution systems. Their feasibility depends primarily on the combination of required voltage and power. Nowadays, they can be installed in system voltages up to 500 kV, being connected directly to substation busbars, transmission line endings, or tertiary windings of large power transformers.

When the combination of power/voltage allows, the benefits of using dry type air core shunt reactors include:

- very low maintenance requirements;
- eco-design (environmentally friendly);
- no need for oil treatment systems or oil retention tanks;
- simple transportation (usually not requiring special permits or hauling);
- simple erection and commissioning;
- shorter lead times;
- simple protection requirements.

Additionally, Grid Solutions' air core reactors offer further benefits, including:

- best-in-class materials and production process, resulting in high quality and reliability of the equipment;
- conservative temperature rise and dielectric design for an extended service life;
- high mechanical strength to withstand elevated short-circuit forces;
- surface treatment for protection against UV radiation and pollution;
- customized space-saving solutions for installation in compact areas.

Handling, installation, and commissioning details of Grid Solutions' air core reactors can be provided upon request.

## Design of Dry Type Air Core Shunt Reactors

Typically, dry type air core reactors for shunt applications are designed using fiberglass-encapsulated construction. The winding consists of numerous insulated aluminum conductors, which are mechanically immobilized and encapsulated in epoxy impregnated fiberglass filaments, forming cylinders (or layers). Depending on the reactor's ratings, one or more cylinders are connected in parallel between the aluminum spiders. The individual cylinders are separated by vertically oriented fiberglass spacers, forming cooling ducts for heat dissipation by means of air flow from the bottom to the top of winding. This construction allows the use of compact coils even for high inductance, reducing installation footprint.

Medium voltage shunt reactors are typically designed with a single coil per phase. For high voltage applications, the shunt reactors can be split into two or more coils in series per phase, in order to meet insulation requirements (dielectric creepage length).

Figure 1 shows a typical dry type air core reactor and its main parts, which are normally included in the standard scope of supply. Other accessories may be part of the supply, upon demand and/or based on Grid Solutions' design criteria, such as corona rings, top hats, elevating structures, line/grounding connectors, etc.

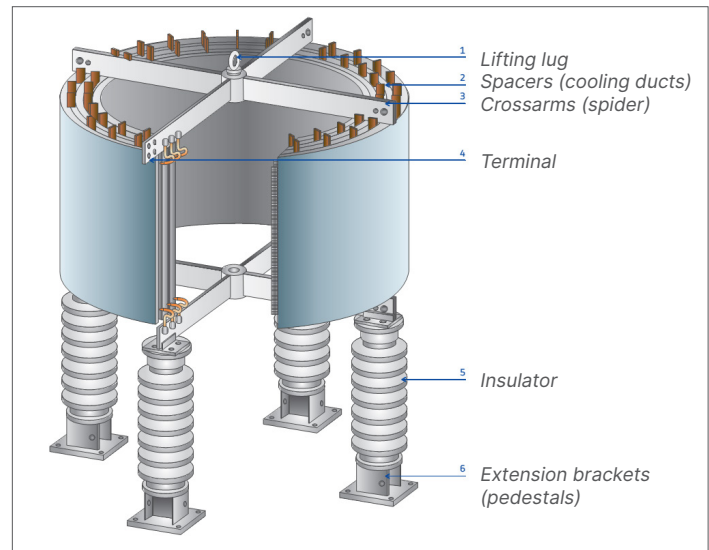

Figure 1: Standard design of an air core reactor.

# Application of Shunt Reactors

The main functions of shunt reactors in transmission and distribution systems are:

- Control of operating voltages
- Support of reactive power compensation
- Reduction of switching transients on transmission lines

Shunt reactors can be installed at both transmission and distribution grids, being directly connected to substation busbars, transmission line endings, and to the tertiary windings of large power transformers, as shown in Figure 2.

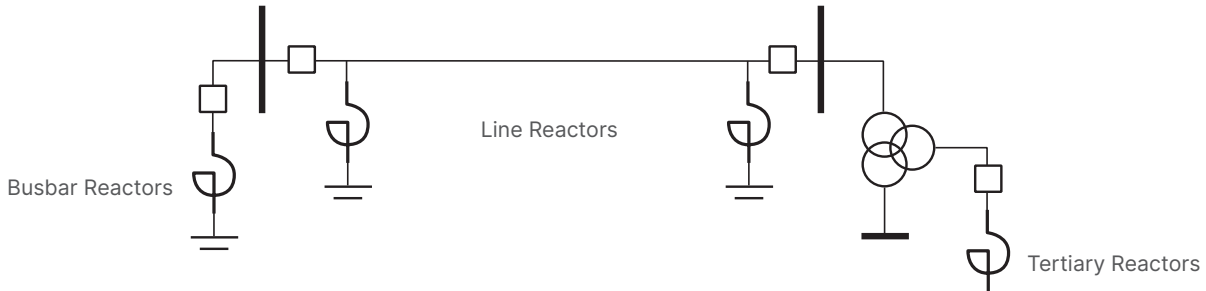

Figure 2: Shunt reactor application in power systems

The rated voltage and reactive power of a shunt reactor, as well its location, are normally determined by system studies, such as load flow and transients. Moreover, the ratings of shunt reactors also depend on the following factors:

- Current and voltage capabilities of the switching devices. The introduction of inductive currents may create severe transient voltages (TRV) over the shunt reactor and across the switching devices. The magnitude and rate-of-rise of the TRV depends on the shunt reactor's inductance and stray capacitances which in turn depend on the voltage, reactive power, grounding, and construction of the shunt reactor. A typical TRV associated with the switching off of the shunt reactor is around 1.7-2.0 p.u. of the rated voltage.
- Connection and grounding type of the shunt reactor. The majority of shunt reactors are connected in star (or wye), being ungrounded for system voltages of 72.5 kV and below, and grounded for system voltages of 115 kV and above. For line reactors, when single-phase auto-reclosing of transmission lines is required, shunt reactors can be grounded by a neutral reactor or resistor. The neutral grounding reactor can also be a dry type air core reactor, with similar construction to the shunt reactors. There are very few cases of delta-connected shunt reactors, mainly related to industrial applications (Figure 3).
- Design/manufacturing capabilities. The size of a shunt reactor depends primarily on its inductance and current. The higher the inductance and/or the current, the bigger the coils. For very low reactive power, the inductance may be extremely high, which may exceed the manufacturing capabilities (maximum diameter x height of the winding machines). For very high reactive power, the current may be extremely high, requiring a huge aluminum mass to achieve a desirable temperature increase and/or losses dissipation. In both cases, the selection of a properly rated voltage for the shunt reactor may eliminate or minimize the impacts on the reactor's design and manufacture.
- Rated voltage and power of the tertiary winding, for tertiary reactors.

Therefore, the reactive power of a shunt reactor depends heavily on its operating voltages. The typical ranges of reactive power (three-phase basis) for each system voltage that result in feasible and competitive dry type air core shunt reactors are presented below:

- 15 kV and below: 0.5 Mvar to 25 Mvar
- 25 kV and 38 kV: 2.5 Mvar to 60 Mvar
- 72.5 kV: 5 Mvar to 100 Mvar
- 138 kV: 7.5 Mvar to 150 Mvar
- 245 kV: 20 Mvar to 200 Mvar
- 345 kV and 400 kV: 50 Mvar to 250 Mvar
- 500 kV: 100 Mvar to 350 Mvar

For reactive power different than the above mentioned ranges, the manufacturer should be consulted to determine technical feasibility.

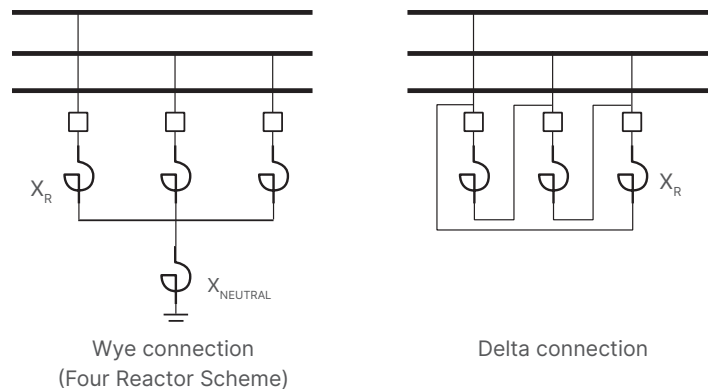

Figure 3: Winding connection of shunt reactors.

# Main Formulas for Shunt Reactors

For the calculation of the positive sequence reactance and current requirements of a shunt reactor, it is necessary to know the rated three-phase reactive power and the rated system voltage, as summarized in the table below.

The zero sequence reactance ( $X_0$ ) depends on the winding connection and grounding of the shunt reactor. For dry type air core units, it can be calculated as follows:

Rating	Wye Connection	Delta Connection
Reactance	$X_R = \frac{U_N^2}{S_{R3\phi}} = \frac{U_N^2}{3 \times S_{R1\phi}}$	$X_R = 3 \times \frac{U_N^2}{S_{R3\phi}} = \frac{U_N^2}{S_{R1\phi}}$
Rated Current	$I_N = \frac{S_{R3\phi}}{\sqrt{3} \times U_N} = \frac{S_{R1\phi}}{U_N / \sqrt{3}} = \frac{U_N}{\sqrt{3} \times X_R}$	$I_N = \frac{S_{R3\phi}}{3 \times U_N} = \frac{S_{R1\phi}}{U_N} = \frac{U_N}{X_R}$
Maximum Continuous Current (Design Current)	$I_{MAX} = \frac{U_{MAX}}{U_N} \times I_N$	$I_{MAX} = \frac{U_{MAX}}{U_N} \times I_N$
Parameters:	$X_R$ = rated reactance per phase (positive sequence) $S_{R3\phi}$ = rated three-phase reactive power $S_{R1\phi}$ = rated reactive power per phase $U_N$ = rated system voltage	$U_{MAX}$ = maximum system operating voltage $I_N$ = rated current $I_{MAX}$ = maximum continuous current

Neutral grounding reactors are generally associated with shunt reactors installed in transmission line terminations to provide a faster extinguishing of the secondary arc current, allowing the automatic reclosing of the transmission line after a fault elimination. (Typically, the reclosing time varies from 0.5 to 1.5 seconds). Grid Solutions at GE Vernova has an exclusive technology for very high impedance/low current neutral grounding reactors, reducing dimensions and required footprint considerably.

The zero sequence reactance ( $X_0$ ) depends on the winding connection and grounding of the shunt reactor. For dry type air core units, it can be calculated as follows:

Wye connection with neutral directly grounded	$X_0 = X_R$
Wye connection with neutral grounded through a reactor	$X_0 = X_R + 3 \times X_{NEUTRAL}$
Wye connection with neutral ungrounded	$X_0 = \infty$
Delta connection	$X_0 = \infty$

## Case Studies

### Case Study 1

#### Open-Circuit Operation of Radial Transmission Lines

The operation of a lossless radial transmission line, which is energized by a generator at the sending ending ( $V_1$ ) and is open-circuited at the receiving ending ( $V_2$ ), can be represented in the matrix form by the ABCD parameters, where  $I_2 = 0$ .

$$\begin{bmatrix} V_1 \\ I_1 \end{bmatrix} = \begin{bmatrix} A & B \\ C & D \end{bmatrix} \times \begin{bmatrix} V_2 \\ I_2 \end{bmatrix} \Rightarrow V_1 = A \cdot V_2 - \left(1 + \frac{ZY}{2}\right) \cdot V_2$$

When inserting shunt reactors at the receiving ending, the ABCD parameters of the line are changed, as described below:

$$\begin{bmatrix} V_1 \\ I_1 \end{bmatrix} = \begin{bmatrix} A & B \\ C & D \end{bmatrix} \times \begin{bmatrix} 0 \\ \frac{1}{X_R} \\ 0 \end{bmatrix} \times \begin{bmatrix} V_2 \\ I_2 \end{bmatrix} \Rightarrow \begin{bmatrix} V_1 \\ I_1 \end{bmatrix} = \begin{bmatrix} A' & B' \\ C' & D' \end{bmatrix} \times \begin{bmatrix} V_2 \\ I_2 \end{bmatrix}$$

So, the relation between the ending voltages of the transmission line is given by:

$$V_1 = A' \cdot V_2 \Rightarrow V_1 = \left( A + \frac{B}{X_R} \right) \cdot V_2 \Rightarrow V_1 = \left( 1 + \frac{ZY}{2} + \frac{L}{L_R} \right) \cdot V_2$$

### Example of Application

Consider a lossless radial transmission line with a frequency of 60 Hz, length  $\ell = 350$  km, and parameters  $z = j 0.32886 \Omega/\text{km}$  and  $bC = j 5.097 \mu\text{S}/\text{km}$ . Estimate the reactive power of the shunt reactors to be installed in the transmission line to provide a maximum operating voltage of 1.05 p.u. at the open-circuited terminal (receiving ending), when the line is energized with 1.0 p.u. in the sending ending.

### Solution

Total impedance and admittance of the transmission line without compensation:

$$Z = j(z \cdot \ell) = j115.1 \Omega$$

$$Y = j(b_c \cdot \ell) = j1783.95 \mu\text{S}$$

Parameter A:

$$A = 1 + \frac{ZY}{2} = 0.8973$$

Operating voltage at the receiving ending of the transmission line without compensation:

$$V_2 = \frac{1}{0.8973} \cdot V_1 = 1.1144 \cdot V_1$$

Calculation of the shunt reactor reactance:

$$V_1 = \left( 1 + \frac{ZY}{2} + \frac{L}{L_R} \right) \cdot V_2$$

$$1.0 = \left( 0.8973 + \frac{115.1}{X_R} \right) \cdot 1.05$$

$$X_R = \frac{115.1}{\frac{1.0}{1.05} - 0.8973} = 2090 \Omega$$

Calculation of the three-phase reactive power of the shunt reactor:

$$S_{R_{3\phi}} = \frac{U_N^2}{X_R} = \frac{525^2}{2090} = 132 \text{ MVar}$$

Calculation of the compensation degree of the transmission line:

In order to make the energization of the line possible by both sides, it is recommended to install shunt reactors with similar ratings in their two terminations.

The line charging of the transmission line is:

$$Q_{C_{3\phi}} = U_N^2 \cdot b_c \cdot \ell = 525^2 \cdot 5.079 \cdot 350 = 490 \text{ MVar}$$

So, the compensation degree is:

$$K_{SH} = 2 \cdot \frac{S_{R_{3\phi}}}{Q_{C_{3\phi}}} = 54\%$$

## Case Study 2

### Open-Circuit Operation of Radial Transmission Lines

Typically, the voltage variation at the high voltage busbar after the switching of a shunt reactor will not be higher than 2% - 3% of the rated voltage. A practical circuit is used to simplify the analysis of voltage control (see Figure 4). The determination of the shunt reactor to provide a required voltage variation in the busbar can be calculated through the short-circuit power of the system at the busbar where the reactor will be connected.

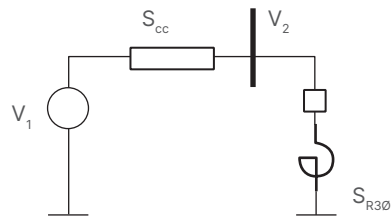

Figure 4: Practical circuit for voltage control analysis

The shunt reactor power rating is given by:

$$V_2 = \frac{V_1}{1 - \frac{S_{R_{3\phi}}}{S_{CC}}} \Rightarrow S_{R_{3\phi}} = S_{CC} \left( \frac{V_1 - V_2}{V_2} \right)$$

### Example of Application

Estimate the reactive power of shunt reactors to be installed in the 34.5 kV busbar in order to reduce the voltage level from 1.02 to 0.99 p.u., considering an available fault current of 25 kA (or short-circuit power of 1485 MVA).

### Solutions

Calculation of the three-phase reactive power of the shunt reactor:

$$S_{R_{3\phi}} = 1485 \cdot \left( \frac{1.02 - 0.99}{0.99} \right) = 45 \text{ MVar}$$

**Remark**

In the analysis above, the on-load tap changer (OLTC) operation of power transformers close to the point of connection of the shunt reactors is not considered. This occurs a few minutes after the shunt reactor switching on/off.

The load-voltage curve shown in Figure 5 gives an example of a comprehensive study of a real transmission system that takes into account all possible load levels in the network and the operation of all tap changers and shunt capacitor banks. The improvement in voltage level at all load levels is clearly visible.

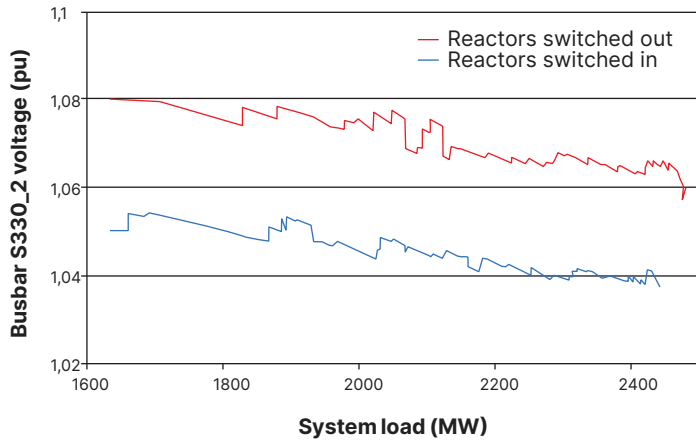

Figure 5: Voltage response with shunt reactors switched in/out.

The next sections will briefly discuss some implementation issues associated with shunt reactors.

**Protection and Grounding**

In most applications of shunt reactors in EHV and HV systems, the star points of the reactors are connected to earth, whereas MV shunt reactors are generally not grounded.

If the star point of the transformer tertiary winding is not earthed, then grounding the reactor would assist in detecting earth faults in this zone. However, such ground fault detection can also be made by means of voltage measurement, with a grounded star primary and open delta secondary voltage transformer used to detect ground faults on the network supplied by the tertiary winding.

Shunt reactors should be equipped with over-current and earth fault protection monitoring the line side current.

In cases where the reactors are connected to the tertiary winding of a transformer, it is most likely that the reactor feeder will be included in the transformer differential protection. Differential protection of the reactor can be achieved by splitting each phase into two legs and monitoring the unbalance current in the star point. This method provides extremely fast and sensitive protection of the reactor's windings, especially in terms of inter-turn faults but requires special coil design (split-phase reactors).

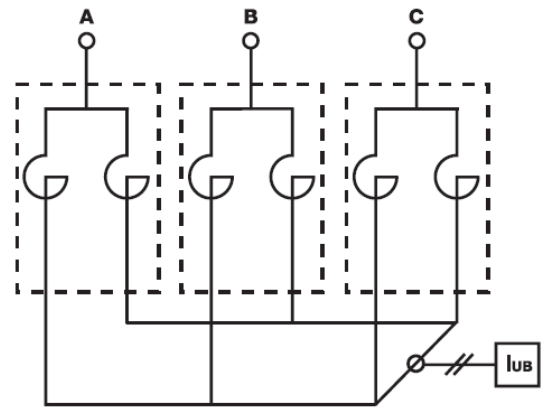

Figure 6A: Differential protection with split-phase shunt reactors.

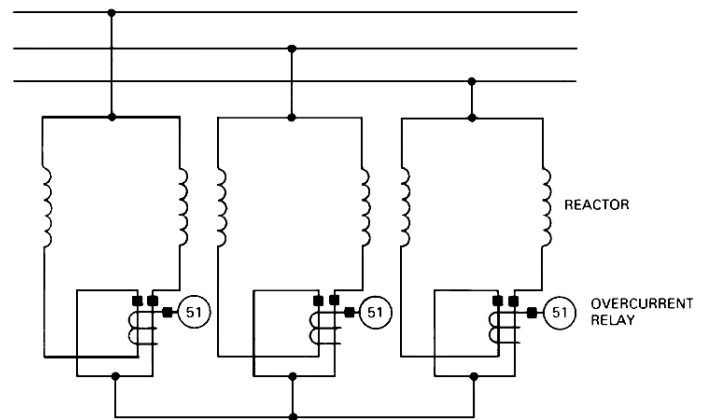

Figure 6B: Split-phase protection: (a) three-phase sensing and (b) single-phase sensing.

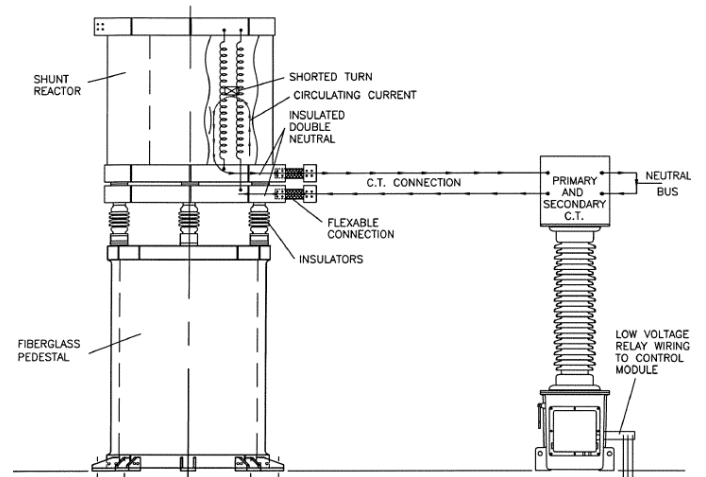

Figure 6C: Split-phase reactor

## Switching of Reactors

IEEE C37.015 provides comprehensive guidelines for the switching requirements of shunt reactors. One of the most important aspects of switching reactors is current chopping caused by forcing the reactor current to zero before the zero crossing. This could result in high voltage across breaker poles.

The introduction of copper/chromium contact material in vacuum circuit breakers overcame the problem of over-voltages as a result of switching, provided other precautions are taken and the circuit breaker is adequately rated for the specific application.

The oscillation frequency and magnitude is determined by the inductance and stray capacitance associated with the reactor, circuit breaker and network components in close proximity to the circuit breaker. These capacitances are generally very low, resulting in high frequency switching transients that are especially harsh on circuit breaker contact surfaces. The oscillation frequency can be reduced by means of surge capacitors placed between the reactor and the circuit breaker.

The effect of such surge capacitors is shown in Figure 7. The frequency of the switching transient is reduced from more than 40 kHz to less than 6 kHz by the introduction of a 100 nF capacitor between phase and earth. The reduced oscillation frequency results in less contact wear and therefore longer life of the circuit breaker, as well as reduced reactor inter-turn stress levels.

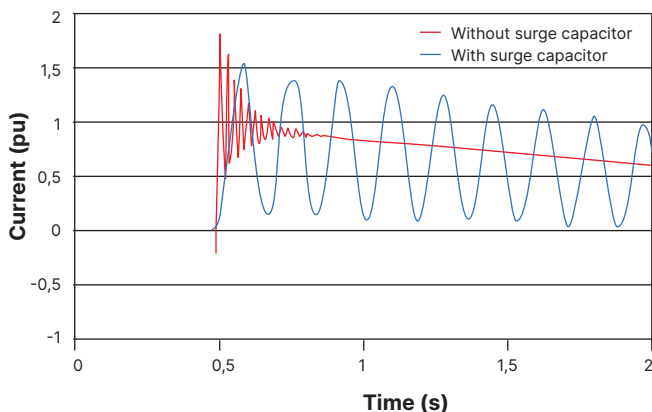

Figure 7: Switching transient frequency with/without surge capacitors.

For voltages up to 34.5 kV, reactor switchers have been developed by some manufacturers especially for shunt reactor application, providing reduced turn-to-turn stress on the reactor during switching and resulting in increased reactor life.

## Practical Considerations

The following additional aspects should be taken into account when studying and designing shunt reactor installations:

1. Most installations of the kind described here contain more than one shunt reactor on the transformer tertiary, in order to provide fine voltage control.
2. Some form of control is required to operate the various steps and this control should take into account the control system of any tap changer that may be present on the transformer primary or secondary.
3. Surge arresters are commonly applied to the reactor and transformer tertiary to avoid excessive voltages during switching.
4. The selection of the right switching equipment results in increased reactor life.
5. Appropriate magnetic and electrical clearances between reactors and other substation equipment must be observed and all footings must be designed for use together with air core reactors. Grid Solutions manuals provide complete details required from receiving to commissioning.

## Conclusions

As the demand for more energy grows, modern transmission/distribution systems are operated close to security limits. The ability to control transmission voltages to the extent possible with shunt reactors is very attractive from a commercial and technical point of view.

The pressure to increase available power to the end user results either in new generation or increasing the efficiency of the system/reducing losses. Shunt reactors are used in transmission systems to increase the capabilities of transmission lines by injecting inductive power to the system. This results in fewer transmission losses and consequently, less new generation is required, indirectly reducing carbon dioxide emissions.

Grid Solutions at GE Vernova is able to supply air core shunt reactors to provide reactive power compensation for electrical systems with rated voltages up to 500 kV. For higher voltage levels, solutions can be provided upon request.

Grid Solutions' top-class materials are associated with more than 50 years of know-how, conservative temperature rise and conservative voltage stress results in one of the market's best options for dry type air core shunt reactors.

## References/standards for design, manufacturing, and testing:

IEEE Std C37.015-2009 – IEEE Guide for the Application of Shunt Reactor Switching

IEEE Std C37.109™-2006 – IEEE Guide for the Protection of Shunt Reactors

IEEE Std C57.21-2008 – IEEE Standard for requirements, Terminology, and test code for Shunt Reactors rated over 500 kVA.

IEEE Std C57.32-2015 – IEEE Standard for requirements, Terminology, and Test Procedures for Neutral grounding devices.

IEEE Std C95.6-2002 – IEEE Standard for Safety Levels With Respect to Human Exposure to Electromagnetic Fields, 0-3 kHz

ICNIRP Guidelines 2010 - Guidelines for limiting exposure to time-varying electric and magnetic fields (1 Hz to 100 kHz)

IEC 60076-6:2007 - Power transformers - Part 6: Reactors

For more information  
visit [governova.com/grid-solutions](https://www.governova.com/grid-solutions)

IEC is a registered trademark of Commission Electrotechnique Internationale. IEEE is a registered trademark of the Institute of Electrical Electronics Engineers, Inc.

GE, and the GE monogram are trademarks of General Electric Company. GE reserves the right to make changes to specifications of products described at any time without notice and without obligation to notify any person of such changes.

© 2024 GE Grid Solutions, LLC, a GE Vernova company, and/or affiliates.  
All rights reserved.

GEA-31994A-(E)  
English  
240506



**GE VERNOVA**