

7

CURRENT TRANSFORMERS

Protective relays of the a-c type are actuated by current and voltage supplied by current and voltage transformers. These transformers provide insulation against the high voltage of the power circuit, and also supply the relays with quantities proportional to those of the power circuit, but sufficiently reduced in magnitude so that the relays can be made relatively small and inexpensive.

The proper application of current and voltage transformers involves the consideration of several requirements, as follows: mechanical construction, type of insulation (dry or liquid), ratio in terms of primary and secondary currents or voltages, continuous thermal rating, short-time thermal and mechanical ratings, insulation class, impulse level, service conditions, accuracy, and connections. Application standards for most of these items are available.¹ Most of them are self-evident and do not require further explanation. Our purpose here and in Chapter 8 will be to concentrate on *accuracy* and *connections* because these directly affect the performance of protective relaying, and we shall assume that the other general requirements are fulfilled.

The accuracy requirements of different types of relaying equipment differ. Also, one application of a certain relaying equipment may have more rigid requirements than another application involving the same type of relaying equipment. Therefore, no general rules can be given for all applications. Technically, an entirely safe rule would be to use the most accurate transformers available, but few would follow the rule because it would not always be economically justifiable.

Therefore, it is necessary to be able to predict, with sufficient accuracy, how any particular relaying equipment will operate from any given type of current or voltage source. This requires that one know how to determine the inaccuracies of current and voltage transformers under different conditions, in order to determine what effect these inaccuracies will have on the performance of the relaying equipment.

Methods of calculation will be described using the data that are published by the manufacturers; these data are generally sufficient. A problem that cannot be solved by calculation using these data should be solved by actual test or should be referred to the manufacturer. This chapter is not intended as a text for a CT designer, but as a generally helpful reference for usual relay-application purposes.

The methods of connecting current and voltage transformers also are of interest in view of the different quantities that can be obtained from different combinations. Knowledge of the polarity of a current or voltage transformer and how to make use of this knowledge for making connections and predicting the results are required.

TYPES OF CURRENT TRANSFORMERS

All types of current transformers¹ are used for protective-relaying purposes. The bushing CT is almost invariably chosen for relaying in the higher-voltage circuits because it is less expensive than other types. It is not used in circuits below about 5 kv or in metal-clad equipment. The bushing type consists only of an annular-shaped core with a secondary winding; this transformer is built into equipment such as circuit breakers, power transformers, generators, or switchgear, the core being arranged to encircle an insulating bushing through which a power conductor passes.

Because the internal diameter of a bushing-CT core has to be large to accommodate the bushing, the mean length of the magnetic path is greater than in other CT's. To compensate for this, and also for the fact that there is only one primary turn, the cross section of the core is made larger. Because there is less saturation in a core of greater cross section, a bushing CT tends to be more accurate than other CT's at high multiples of the primary-current rating. At low currents, a bushing CT is generally less accurate because of its larger exciting current.

CALCULATION OF CT ACCURACY

Rarely, if ever, is it necessary to determine the phase-angle error of a CT used for relaying purposes. One reason for this is that the load on the secondary of a CT is generally of such highly lagging power factor that the secondary current is practically in phase with the exciting current, and hence the effect of the exciting current on the phase-angle accuracy is negligible. Furthermore, most relaying applications can tolerate what for metering purposes would be an intolerable phase-angle error. If the ratio error can be tolerated, the phase-angle error can be neglected. Consequently, phase-angle errors will not be discussed further. The technique for calculating the phase-angle error will be evident, once one learns how to calculate the ratio error.

Accuracy calculations need to be made only for three-phase- and single-phase-to-ground-fault currents. If satisfactory results are thereby obtained, the accuracy will be satisfactory for phase-to-phase and two-phase-to-ground faults.

CURRENT-TRANSFORMER BURDEN

All CT accuracy considerations require knowledge of the CT burden. The *external* load applied to the secondary of a current transformer is called the "burden." The burden is expressed preferably in terms of the impedance of the load and its resistance and reactance components. Formerly, the practice was to express the burden in terms of volt-amperes and power factor, the volt-amperes being what would be consumed in the burden impedance at rated secondary current (in other words, rated secondary current squared times the burden impedance). Thus, a burden of 0.5-ohm impedance may be expressed also as "12.5 volt-amperes at 5 amperes," if we assume the usual 5-ampere secondary rating. The volt-ampere terminology is no longer standard, but it needs defining because it will be found in the literature and in old data.

The term "burden" is applied not only to the total external load connected to the terminals of a current transformer but also to elements of that load. Manufacturers'

publications give the burdens of individual relays, meters, etc., from which, together with the resistance of interconnecting leads, the total CT burden can be calculated.

The CT burden impedance decreases as the secondary current increases, because of saturation in the magnetic circuits of relays and other devices. Hence, a *given burden may apply only for a particular value of secondary current*. The old terminology of “volt-amperes at 5 amperes” is most confusing in this respect since it is not necessarily the actual volt-amperes with 5 amperes flowing, but is what the volt-amperes would be at 5 amperes if there were no saturation. Manufacturers’ publications give impedance data for several values of overcurrent for some relays for which such data are sometimes required. Otherwise, data are provided only for one value of CT secondary current. If a publication does not clearly state for what value of current the burden applies, this information should be requested. Lacking such saturation data, one can obtain it easily by test. At high saturation, the impedance approaches the d-c resistance. Neglecting the reduction in impedance with saturation makes it appear that a CT will have more inaccuracy than it actually will have. Of course, if such apparently greater inaccuracy can be tolerated, further refinements in calculation are unnecessary. However, in some applications neglecting the effect of saturation will provide overly optimistic results; consequently, it is safer always to take this effect into account.

It is usually sufficiently accurate to add series burden impedances arithmetically. The results will be slightly pessimistic, indicating slightly greater than actual CT ratio inaccuracy. But, if a given application is so borderline that vector addition of impedances is necessary to prove that the CT’s will be suitable, such an application should be avoided.

If the impedance at pickup of a tapped overcurrent-relay coil is known for a given pickup tap, it can be estimated for pickup current for any other tap. The reactance of a tapped coil varies as the square of the coil turns, and the resistance varies approximately as the turns. At pickup, there is negligible saturation, and the resistance is small compared with the reactance. Therefore, it is usually sufficiently accurate to assume that the impedance varies as the square of the turns. The number of coil turns is inversely proportional to the pickup current, and therefore the impedance varies inversely approximately as the square of the pickup current.

Whether CT’s are connected in wye or in delta, the burden impedances are always connected in wye. With wye-connected CT’s the neutrals of the CT’s and of the burdens are connected together, either directly or through a relay coil, except when a so-called “zerophase-sequence-current shunt” (to be described later) is used.

It is seldom correct simply to add the impedances of series burdens to get the total, whenever two or more CT’s are connected in such a way that their currents may add or subtract in some common portion of the secondary circuit. Instead, one must calculate the sum of the voltage drops and rises in the external circuit from one CT secondary terminal to the other for assumed values of secondary currents flowing in the various branches of the external circuit. The effective CT burden impedance for each combination of assumed currents is the calculated CT terminal voltage divided by the assumed CT secondary current. This effective impedance is the one to use, and it may be larger or smaller than the actual impedance which would apply if no other CT’s were supplying current to the circuit. If the primary of an auxiliary CT is to be connected into the secondary of a CT whose accuracy is being studied, one must know the impedance of the auxiliary CT viewed

from its primary with its secondary short-circuited. To this value of impedance must be added the impedance of the auxiliary CT burden as viewed from the primary side of the auxiliary CT; to obtain this impedance, multiply the actual burden impedance by the square of the ratio of primary to secondary turns of the auxiliary CT. It will become evident that, with an auxiliary CT that steps up the magnitude of its current from primary to secondary, very high burden impedances, when viewed from the primary, may result.

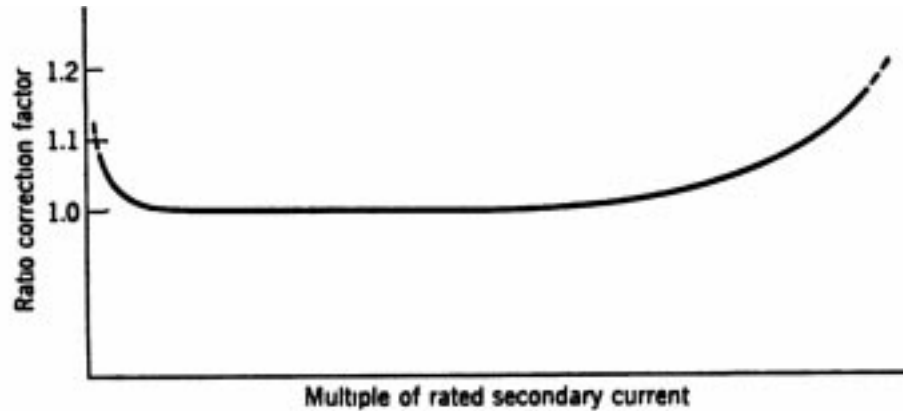

Fig. 1. Ratio-correction-factor curve of a current transformer.

RATIO-CORRECTION-FACTOR CURVES

The term “ratio-correction factor” is defined as “that factor by which the marked (or nameplate) ratio of a current transformer must be multiplied to obtain the true ratio.” The ratio errors of current transformers used for relaying are such that, for a given magnitude of primary current, the secondary current is less than the marked ratio would indicate; hence, the ratio-correction factor is greater than 1.0. A ratio-correction-factor curve is a curve of the ratio-correction factor plotted against multiples of rated primary or secondary current for a given constant burden, as in Fig. 1. Such curves give the most accurate results because the only errors involved in their use are the slight differences in accuracy between CT’s having the same nameplate ratings, owing to manufacturers’ tolerances. Usually, a family of such curves is provided for different typical values of burden.

To use ratio-correction-factor curves, one must calculate the CT burden for each value of secondary current for which he wants to know the CT accuracy. Owing to variation in burden with secondary current because of saturation, no single RCF curve will apply for all currents because these curves are plotted for constant burdens; instead, one must use the applicable curve, or interpolate between curves, for each different value of secondary current. In this way, one can calculate the primary currents for various assumed values of secondary current; or, for a given primary current, he can determine, by trial and error, what the secondary current will be.

The difference between the actual burden power factor and the power factor for which the RCF curves are drawn may be neglected because the difference in CT error will be negligible. Ratio-correction-factor curves are drawn for burden power factors approximately like those usually encountered in relay applications, and hence there is usually not much discrepancy. Any application should be avoided where successful relay operation depends on such small margins in CT accuracy that differences in burden power factor would be of any consequence.

Extrapolations should not be made beyond the secondary current or burden values for which the RCF curves are drawn, or else unreliable results will be obtained.

Ratio-correction-factor curves are considered standard application data and are furnished by the manufacturers for all types of current transformers.

CALCULATION OF CT ACCURACY USING A SECONDARY-EXCITATION CURVE²

Figure 2 shows the equivalent circuit of a CT. The primary current is assumed to be transformed perfectly, with no ratio or phase-angle error, to a current I_p/N , which is often called “the primary current referred to the secondary.” Part of the current may be considered consumed in exciting the core, and this current (I_e) is called “the secondary excitation current.” The remainder (I_s) is the true secondary current. It will be evident that the secondary-excitation current is a function of the secondary-excitation voltage (E_s) and the secondary-excitation impedance (Z_e). The curve that relates E_s and I_e is called “the secondary-excitation curve,” an example of which is shown in Fig. 3. It will also be evident that the secondary current is a function of E_s and the total impedance in the secondary circuit. This total impedance is composed of the effective resistance and the leakage reactance of the secondary winding and the impedance of the burden.

Figure 2 shows also the primary-winding impedance, but this impedance does not affect the ratio error. It affects only the magnitude of current that the power system can pass through the CT primary, and is of importance only in low-voltage circuits or when a CT is connected in the secondary of another CT.

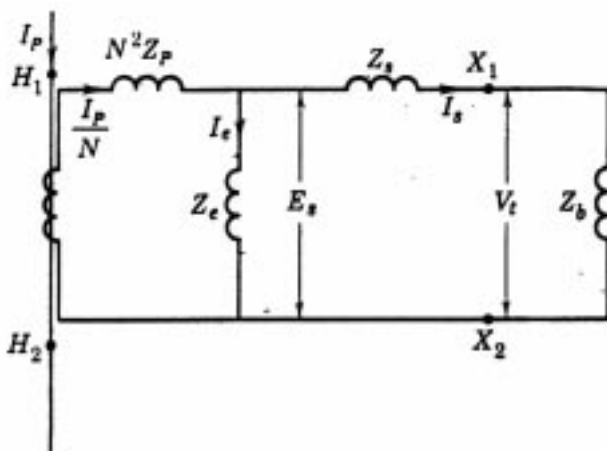

Fig. 2. Equivalent circuit of a current transformer. I_p = primary current in rms amperes; N = ratio of secondary to primary turns; Z_p = primary-winding impedance in ohms; I_e = secondary-excitation current in rms amperes; Z_e = secondary-excitation impedance in ohms; E_s = secondary-excitation voltage in rms volts; Z_s = secondary-winding impedance in ohms; I_s = secondary current in rms amperes; V_t = secondary terminal voltage in rms volts; Z_b = burden impedance in ohms.

If the secondary-excitation curve and the impedance of the secondary winding are known, the ratio accuracy can be determined for any burden. It is only necessary to assume a magnitude of secondary current and to calculate the total voltage drop in the secondary winding and burden for this magnitude of current. This total voltage drop is equal numerically to E_s . For this value of E_s , the secondary-excitation curve will give I_e . Adding I_e to I_s gives I_p/N , and multiplying I_p/N by N gives the value of primary current that will produce the assumed value of I_s . The ratio-correction factor will be $I_p/N I_s$. By assuming

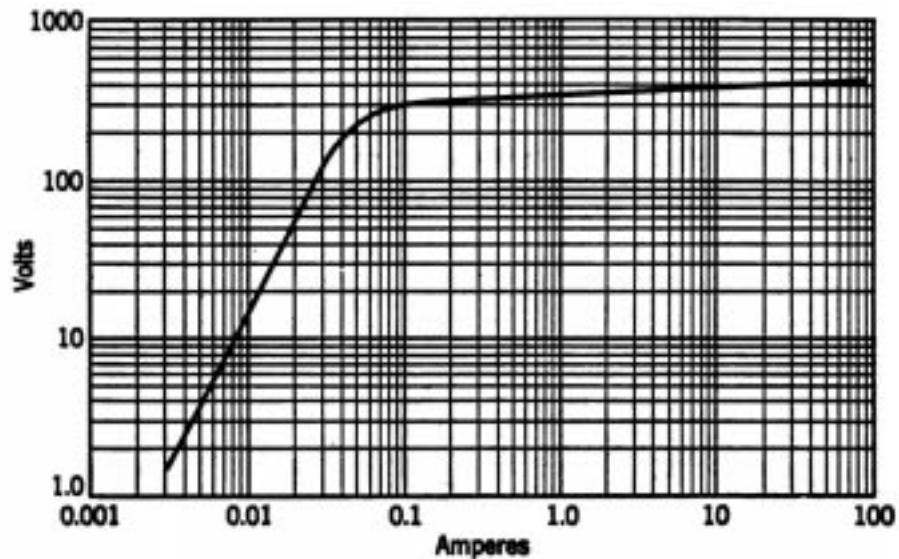

Fig. 3 Secondary-excitation characteristic. Frequency, 60; internal resistance, 1.08 ohms; secondary turns, 240.

several values of I_s , and obtaining the ratio-correction factor for each, one can plot a ratio-correction-factor curve. It will be noted that adding I_s arithmetically to I_e may give a ratio-correction factor that is slightly higher than the actual value, but the refinement of vector addition is considered to be unnecessary.

The secondary resistance of a CT may be assumed to be the d-c resistance if the effective value is not known. The secondary leakage reactance is not generally known except to CT designers; it is a variable quantity depending on the construction of the CT and on the degree of saturation of the CT core. Therefore, the secondary-excitation-curve method of accuracy determination does not lend itself to general use except for bushing-type, or other, CT's with completely distributed secondary windings, for which the secondary leakage reactance is so small that it may be assumed to be zero. In this respect, one should realize that, even though the total secondary winding is completely distributed, tapped portions of this winding may not be completely distributed; to ignore the secondary leakage reactance may introduce significant errors if an undistributed tapped portion is used.

The secondary-excitation-curve method is intended only for current magnitudes or burdens for which the calculated ratio error is approximately 10% or less. When the ratio error appreciably exceeds this value, the wave form of the secondary-excitation current—and hence of the secondary current—begins to be distorted, owing to saturation of the CT core. This will produce unreliable results if the calculations are made assuming sinusoidal waves, the degree of unreliability increasing as the current magnitude increases. Even though one could calculate accurately the magnitude and wave shape of the secondary current, he would still have the problem of deciding how a particular relay would respond to such a current. Under such circumstances, the safest procedure is to resort to a test.

Secondary-excitation data for bushing CT's are provided by manufacturers. Occasionally, however, it is desirable to be able to obtain such data by test. This can be done accurately enough for all practical purposes merely by open-circuiting the primary circuit, applying a-c voltage of the proper frequency to the secondary, and measuring the current that flows

into the secondary. The voltage should preferably be measured by a rectifier-type voltmeter. The curve of rms terminal voltage versus rms secondary current is approximately the secondary-excitation curve for the test frequency. The actual excitation voltage for such a test is the terminal voltage minus the voltage drop in the secondary resistance and leakage reactance, but this voltage drop is negligible compared with the terminal voltage until the excitation current becomes large, when the GT core begins to saturate. If a bushing CT with a completely distributed secondary winding is involved, the secondary-winding voltage drop will be due practically only to resistance, and corrections in excitation voltage for this drop can be made easily. In this way, sufficiently accurate data can be obtained up to a point somewhat beyond the knee of the secondary-excitation curve, which is usually all that is required. This method has the advantage of providing the data with the CT mounted in its accustomed place.

Secondary-excitation data for a given number of secondary turns can be made to apply to a different number of turns on the same CT by expressing the secondary-excitation voltages in “volts ” and the corresponding secondary-excitation currents in “ampere-turns.” When secondary-excitation data are plotted in terms of volts-per-turn and ampere-turns, a single curve will apply to any number of turns.

The secondary-winding impedance can be found by test, but it is usually impractical to do so except in the laboratory. Briefly, it involves energizing the primary and secondary windings with equal and opposite ampere-turns, approximately equal to rated values, and measuring the voltage drop across the secondary winding.³ This voltage divided by the secondary current is called the “unsaturated secondary-winding impedance.” If we know the secondary-winding resistance, the unsaturated secondary leakage reactance can be calculated. If a bushing CT has secondary leakage flux because of an undistributed secondary winding, the CT should be tested in an enclosure of magnetic material that is the same as its pocket in the circuit breaker or transformer, or else most unreliable results will be obtained.

The most practical way to obtain the secondary leakage reactance may sometimes be to make an overcurrent ratio test, power-system current being used to get good wave form, with the CT in place, and with its secondary short-circuited through a moderate burden. The only difficulty of this method is that some means is necessary to measure the primary current accurately. Then, from the data obtained, and by using the secondary-excitation curve obtained as previously described, the secondary leakage reactance can be calculated. Such a calculation should be accurately made, taking into account the vector relations of the exciting and secondary currents and adding the secondary and burden resistance and reactance vectorially.

ASA ACCURACY CLASSIFICATION

The ASA accuracy classification⁴ for current transformers used for relaying purposes provides a measure of a CT's accuracy. This method of classification assumes that the CT is supplying 20 times its rated secondary current to its burden, and the CT is classified on the basis of the maximum rms value of voltage that it can maintain at its secondary terminals without its ratio error exceeding a specified amount.

Standard ASA accuracy classifications are as shown. The letter "H" stands for "high internal secondary impedance," which is a characteristic of CT's having concentrated secondary windings. The letter "L" stands for "low internal secondary impedance," which is a characteristic of bushing-type CT's having completely distributed secondary windings or of window type having two to four secondary coils with low secondary leakage reactance. The number before the letter is the maximum specified ratio error in percent ($= 100|R_{CF} - 1|$), and the number after the letter is the maximum specified secondary terminal voltage at which the specified ratio error may exist, for a secondary current of 20 times rated. For a 5-ampere secondary, which is the usual rating, dividing the maximum specified voltage by 100 amperes (20×5 amperes) gives the maximum specified burden impedance through which the CT will pass 100 amperes with no more than the specified ratio error.

10H10	10L10
10H20	10L20
10H50	10L50
10H100	10L100
10H200	10L200
10H400	10L400
10H800	10L800
2.5H10	2.5L10
2.5H20	2.5L20
2.5H50	2.5L50
2.5H100	2.5L100
2.5H200	2.5L200
2.5H400	2.5L400
2.5H800	2.5L800

At secondary currents from 20 to 5 times rated, the H class of transformer will accommodate increasingly higher burden impedances than at 20 times rated without exceeding the specified maximum ratio error, so long as the product of the secondary current times the burden impedance does not exceed the specified maximum voltage at 20 times rated. This characteristic is the deciding factor when there is a question whether a given CT should be classified as "H" or as "L." At secondary currents from rated to 5 times rated, the maximum permissible burden impedance at 5 times rated (calculated as before) must not be exceeded if the maximum specified ratio error is not to be exceeded.

At secondary currents from rated to 20 times rated, the L class of transformer may accommodate no more than the maximum specified burden impedance at 20 times rated without exceeding the maximum specified ratio error. This assumes that the secondary leakage reactance is negligible.

The reason for the foregoing differences in the permissible burden impedances at currents below 20 times rated is that in the H class of transformer, having the higher secondary-winding impedance, the voltage drop in the secondary winding decreases with reduction in secondary current more rapidly than the secondary-excitation voltage decreases with the reduction in the allowable amount of exciting current for the specified ratio error. This fact will be better understood if one will calculate permissible burden impedances at reduced currents, using the secondary-excitation method.

For the same voltage and error classifications, the H transformer is better than the L for currents up to 20 times rated.

In some cases, the ASA accuracy classification will give very conservative results in that the actual accuracy of a CT may be nearly twice as good as the classification would indicate. This is particularly true in older CT's where no design changes were made to make them conform strictly to standard ASA classifications. In such cases, a CT that can actually maintain a terminal voltage well above a certain standard classification value, but not quite as high as the next higher standard value, has to be classified at the lower value. Also, some CT's can maintain terminal voltages in excess of 800 volts, but because there is no higher standard voltage rating, they must be classified "800."

The principal utility of the ASA accuracy classification is for specification purposes, to provide an indication of CT quality. The higher the number after the letter H or L, the better is the CT. However, a published ASA accuracy classification applies only if the full secondary winding is used; it does not apply to any portion of a secondary winding, as in tapped bushing-CT windings. It is perhaps obvious that with fewer secondary turns, the output voltage will be less. A bushing CT that is superior when its full secondary winding is used may be inferior when a tapped portion of its winding is used if the partial winding has higher leakage reactance because the turns are not well distributed around the full periphery of the core. In other words, the ASA accuracy classification for the full winding is not necessarily a measure of relative accuracy if the full secondary winding is not used.

If a bushing CT has completely distributed tap windings, the ASA accuracy classification for any tapped portion can be derived from the classification for the total winding by multiplying the maximum specified voltage by the ratio of the turns. For example, assume that a given 1200/5 bushing CT with 240 secondary turns is classified as 10L400; if a 120-turn completely distributed tap is used, the applicable classification is 10L200, etc. This assumes that the CT is not actually better than its classification.

Strictly speaking, the ASA accuracy classification is for a burden having a specified power factor. However, for practical purposes, the burden power factor may be ignored.

If the information obtainable from the ASA accuracy classification indicates that the CT is suitable for the application involved, no further calculations are necessary. However, if the CT appears to be unsuitable, a more accurate study should be made before the CT is rejected.

SERIES CONNECTION OF LOW-RATIO BUSHING CT'S

It will probably be evident from the foregoing that a low-ratio bushing CT, having 10 to 20 secondary turns, has rather poor accuracy at high currents. And yet, occasionally, such CT's cannot be avoided, as for example, where a high-voltage, low-current circuit or power-transformer winding is involved where rated full-load current is only, say, 50 amperes. Then, two bushing CT's per phase are sometimes used with their secondaries connected in series. This halves the burden on each CT, as compared with the use of one CT alone, without changing the over-all ratio. And, consequently, the secondary-excitation voltage is halved, and the secondary-excitation current is considerably reduced with a resulting large improvement in accuracy. Such an arrangement may require voltage protectors to hold down the secondary voltage should a fault occur between the primaries of the two CT's.

THE TRANSIENT OR STEADY-STATE ERRORS OF SATURATED CT'S

To calculate first the transient or steady-state output of saturated CT's, and then to calculate at all accurately the response of protective relays to the distorted wave form of the CT output, are a most formidable problem. With perhaps one exception,⁵ there is little in the literature that is very helpful in this respect.

Fortunately, one can get along quite well without being able to make such calculations. With the help of calculating devices, comprehensive studies⁶ have been made that provide general guiding principles for applying relays so that they will perform properly even though the CT output is affected by saturation. And relaying equipments have been devised that can be properly adjusted on the basis of very simple calculations. Examples of such equipments will be described later.

We are occasionally concerned lest a CT be too accurate when extremely high primary short-circuit currents flow! Even though the CT itself may be properly applied, the secondary current may be high enough to cause thermal or mechanical damage to some element in the secondary circuit before the short-circuit current can be interrupted. One should not assume that saturation of a CT core will limit the magnitude of the secondary current to a safe value. At very high primary currents, the air-core coupling between primary and secondary of wound-type CT's will cause much more secondary current to flow than one might suspect. It is recommended that, if the short-time thermal or mechanical limit of some element of the secondary circuit would be exceeded should the CT maintain its nameplate ratio, the CT manufacturer should be consulted. Where there is such possibility, damage can be prevented by the addition of a small amount of series resistance to the existing CT burden.

OVERVOLTAGE IN SATURATED CT SECONDARIES

Although the *rms* magnitude of voltage induced in a CT secondary is limited by core saturation, very high voltage *peaks* can occur.⁷ Such high voltages are possible if the CT burden impedance is high, and if the primary current is many times the CT's continuous rating. The peak voltage occurs when the rate-of-change of core flux is highest, which is approximately when the flux is passing through zero. The maximum flux density that may be reached does not affect the magnitude of the peak voltage. Therefore, the magnitude

of the peak voltage is practically independent of the CT characteristics other than the nameplate ratio.

One series of tests on bushing CT's produced peak voltages whose magnitudes could be expressed empirically as follows:

$$e = 3.5 ZI^{0.53}$$

where e = peak voltage in volts.

Z = unsaturated magnitude of CT burden impedance in ohms.

I = primary current divided by the CT's nameplate ratio. (Or, in other words, the rms magnitude of the secondary current if the ratio-correction factor were 1.0.)

The value of Z should include the unsaturated magnetizing impedance of any idle CT's that may be in parallel with the useful burden. If a tap on the secondary winding is being used, as with a bushing CT, the peak voltage across the full winding will be the calculated value for the tap multiplied by the ratio of the turns on the full winding to the turns on the tapped portion being used; in other words, the CT will step up the voltage as an autotransformer. Because it is the practice to ground one side of the secondary winding, the voltage that is induced in the secondary will be impressed on the insulation to ground. The standard switchgear high potential test to ground is 1500 volts rms, or 2121 volts peak; and the standard CT test voltage is 2475 volts rms or 3500 volts peak.¹ The lower of these two should not be exceeded.

Harmfully high secondary voltages may occur in the CT secondary circuit of generator differential-relaying equipment when the generator kva rating is low but when very high short-circuit kva can be supplied by the system to a short circuit at the generator's terminals. Here, the magnitude of the primary current on the system side of the generator windings may be many times the CT rating. These CT's will try to supply very high secondary currents to the operating coils of the generator differential relay, the unsaturated impedance of which may be quite high. The resulting high peak voltages could break down the insulation of the CT's, the secondary wiring, or the differential relays, and thereby prevent the differential relays from operating to trip the generator breakers.

Such harmfully high peak voltages are not apt to occur for this reason with other than motor or generator differential-relaying equipments because the CT burdens of other equipments are not usually so high. But, wherever high voltage is possible, it can be limited to safe values by overvoltage protectors.

Another possible cause of overvoltage is the switching of a capacitor bank when it is very close to another energized capacitor bank.⁸

The primary current of a CT in the circuit of a capacitor bank being energized or de-energized will contain transient high-frequency currents. With high-frequency primary and secondary currents, a CT burden reactance, which at normal frequency is moderately low, becomes very high, thereby contributing to CT saturation and high peak voltages across the secondary. Overvoltage protectors may be required to limit such voltages to safe values.

It is recommended that the CT manufacturer be consulted whenever there appears to be a need for overvoltage protectors. The protector characteristics must be coordinated with the requirements of a particular application to (1) limit the peak voltage to safe values, (2) not interfere with the proper functioning of the protective-relaying equipment energized from the CT's, and (3) withstand the total amount of energy that the protector will have to absorb.

PROXIMITY EFFECTS

Large currents flowing in a conductor close to a current transformer may greatly affect its accuracy. A designer of compact equipment, such as metal-enclosed switchgear, should guard against this effect. If one has all the necessary data, it is a reasonably simple matter to calculate the necessary spacings to avoid excessive error.⁹

POLARITY AND CONNECTIONS

The relative polarities of CT primary and secondary terminals are identified either by painted polarity marks or by the symbols " H_1 " and " H_2 " for the primary terminals and " X_1 " and " X_2 " for the secondary terminals. The convention is that, when primary current enters the H_1 terminal, secondary current leaves the X_1 terminal, as shown by the arrows in Fig. 4. Or, when current enters the H_2 terminal, it leaves the X_2 terminal.

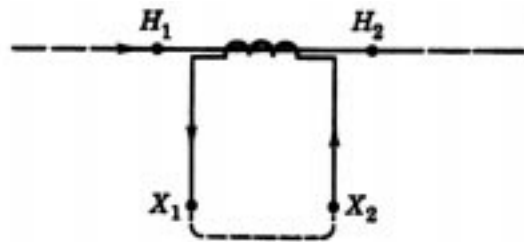

Fig. 4. The polarity of current trans the corresponding terminals in formers.

When paint is used, the terminals corresponding to H_1 and X_1 are identified. Standard practice is to show connection diagrams merely by squares, as in Fig. 5.

Since a-c current is continually reversing its direction, one might well ask what the significance is of polarity marking. Its significance is in showing the direction of current flow relative to another current or to a voltage, as well as to aid in making the proper connections. If CT's were not interconnected, or if the current from one CT did not have to cooperate with a current from another CT, or with a voltage from a voltage source, to produce some desired result such as torque in a relay, there would be no need for polarity marks.

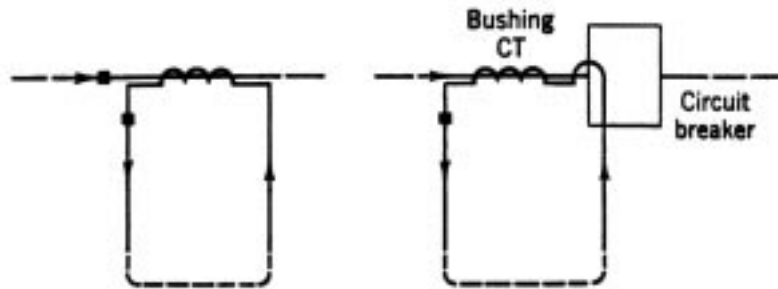

Fig. 5. Convention for showing polarity on diagrams.

WYE CONNECTION

CT's are connected in wye or in delta, as the occasion requires. Figure 6 shows a wye connection with phase and ground relays. The currents I_a , I_b , and I_c are the vector currents, and the CT ratio is assumed to be 1/1 to simplify the mathematics. Vectorially, the primary and secondary currents are in phase, neglecting phase-angle errors in the CT's.

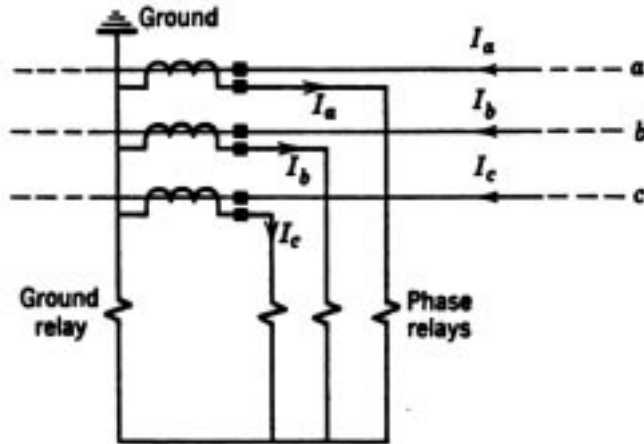

Fig. 6. Wye connection of current transformers.

The symmetrical-component method of analysis is a powerful tool, not only for use in calculating the power-system currents and voltages for unbalanced faults but also for analyzing the response of protective relays. In terms of phase-sequence components of the power-system currents, the output of wye-connected CT's is as follows:

$$I_a = I_{a1} + I_{a2} + I_{a0}$$

$$I_b = I_{b1} + I_{b2} + I_{b0} = a^2 I_{a1} + a I_{a2} + I_{a0}$$

$$I_c = I_{c1} + I_{c2} + I_{c0} = a I_{a1} + a^2 I_{a2} + I_{a0}$$

$$I_a + I_b + I_c = I_{a0} + I_{b0} + I_{c0} = 3I_{a0} = 3I_{b0} = 3I_{c0}$$

where 1, 2, and 0 designate the positive-, negative-, and zero-phase-sequence components, respectively, and where "a" and "a²" are operators that rotate a quantity counterclockwise 120° and 240°, respectively.

DELTA CONNECTION

With delta-connected CT's, two connections are possible, as shown in Fig. 7. In terms of the phase-sequence components, I_a , I_b , and I_c are the same as for the wye-connected CT's. The output currents of the delta connections of Fig. 7 are, therefore:

Connection A.

$$\begin{aligned} I_a - I_b &= (I_{a1} - I_{b1}) + (I_{a2} - I_{b2}) \\ &= (1 - a^2)I_{a1} + (1 - a)I_{a2} \\ &= \left(\frac{3}{2} + j\sqrt{3}/2\right) I_{a1} + \left(\frac{3}{2} - j\sqrt{3}/2\right) I_{a2} \end{aligned}$$

$$\begin{aligned} I_b - I_c &= (1 - a^2) I_{b1} + (1 - a) I_{b2} \\ &= a^2(1 - a^2) I_{a1} + a(1 - a) I_{a2} \\ &= (a^2 - a) I_{a1} + (a - a^2) I_{a2} \\ &= -j\sqrt{3} I_{a1} + j\sqrt{3} I_{a2} \end{aligned}$$

$$\begin{aligned} I_c - I_a &= (1 - a^2) I_{c1} + (1 - a) I_{c2} \\ &= a(1 - a^2) I_{a1} + a^2(1 - a) I_{a2} \\ &= (a - 1) I_{a1} + (a^2 - 1) I_{a2} \\ &= \left(-\frac{3}{2} + j\sqrt{3}/2\right) I_{a1} + \left(-\frac{3}{2} - j\sqrt{3}/2\right) I_{a2} \end{aligned}$$

Connection B.

$$\begin{aligned} I_a - I_c &= -(I_c - I_a) \\ &= \left(\frac{3}{2} - j\sqrt{3}/2\right) I_{a1} + \left(\frac{3}{2} + j\sqrt{3}/2\right) I_{a2} \end{aligned}$$

$$\begin{aligned} I_b - I_a &= -(I_a - I_b) \\ &= \left(-\frac{3}{2} - j\sqrt{3}/2\right) I_{a1} + \left(-\frac{3}{2} + j\sqrt{3}/2\right) I_{a2} \end{aligned}$$

$$\begin{aligned} I_c - I_b &= -(I_b - I_c) \\ &= j\sqrt{3} I_{a1} - j\sqrt{3} I_{a2} \end{aligned}$$

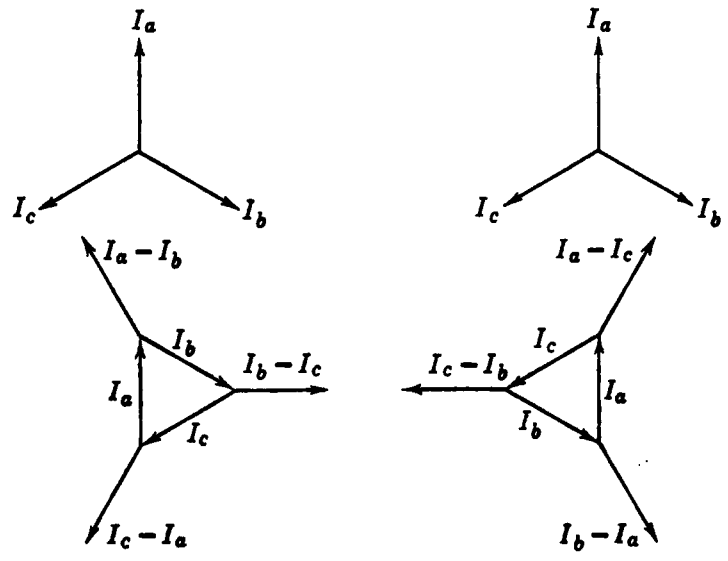
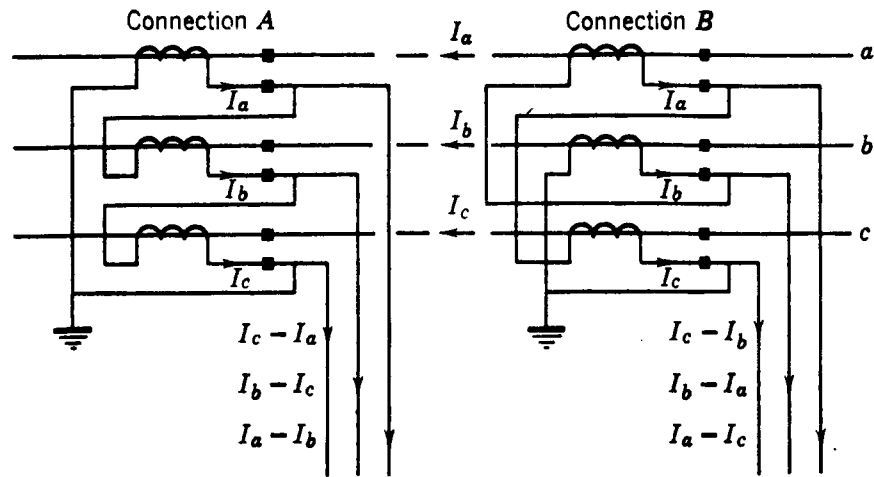

Fig. 7. Delta connections of current transformers and vector diagrams for balanced three-phase currents.

It will be noted that the zero-phase-sequence components are not present in the output circuits; they merely circulate in the delta connection. It will also be noted that connection B is merely the reverse of connection A.

For three-phase faults, only positive-phase-sequence components are present. The output currents of connection A become:

$$I_a - I_b = \left(\frac{3}{2} + j\sqrt{3}/2\right) I_{a1}$$

$$I_b - I_c = -j\sqrt{3} I_{a1}$$

$$I_c - I_a = \left(-\frac{3}{2} + j\sqrt{3}/2\right) I_{a1}$$

For a phase-b-to-phase-c fault, if we assume the same distribution of positive- and negative-phase-sequence currents (which is permissible if we assume that the negative-phase-sequence impedances equal the positive-phase-sequence impedances), $I_{a2} = -I_{a1}$, and the output currents of connection A become:

$$I_a - I_b = j\sqrt{3} I_{a1}$$

$$I_b - I_c = -j2\sqrt{3} I_{a1}$$

$$I_c - I_a = j\sqrt{3} I_{a1}$$

For a phase-a-to-ground fault, if we again assume the same distribution of positive- and negative-phase-sequence currents, $I_{a2} = I_{a1}$, and the output currents of connection A become:

$$I_a - I_b = 3I_{a1}$$

$$I_b - I_c = 0$$

$$I_c - I_a = -3I_{a1}$$

The currents for a two-phase-to-ground fault between phases b and c can be obtained in a similar manner if one knows the relation between the impedances in the negative- and zero-phase-sequence networks. It is felt, however, that the foregoing examples are sufficient to illustrate the technique involved. The assumptions that were made as to the distribution of the currents are generally sufficiently accurate, but they are not a necessary part of the technique; in any actual case, one would know the true distribution and also any angular differences that might exist, and these could be entered in the fundamental equations.

The output currents from wye-connected CT's can be handled in a similar manner.

THE ZERO-PHASE-SEQUENCE-CURRENT SHUNT

Figure 8 shows how three auxiliary CT's can be connected to shunt zero-phase-sequence currents away from relays in the secondary of wye-connected CT's. Other forms of such a shunt exist, but the one shown has the advantage that the ratio of the auxiliary CT's is not important so long as all three are alike. Such a shunt is useful in a differential circuit where the main CT's must be wye-connected but where zero-phase-sequence currents must be kept from the phase relays. Another use is to prevent misoperation of single-phase directional relays during ground faults under certain conditions. These will be discussed more fully later.

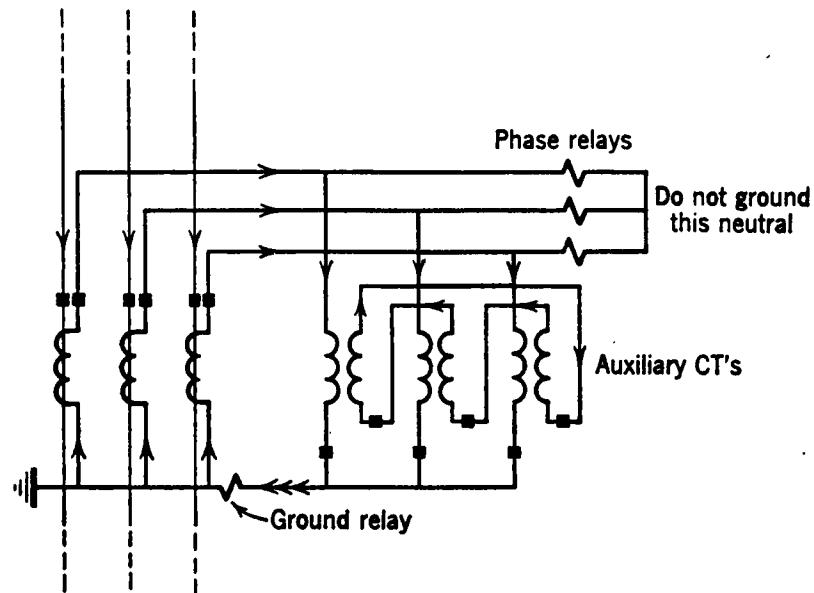

Fig. 8. A zero-phase-sequence-current shunt. Arrows show flow of zero-phase-sequence current.

PROBLEMS

1. What is the ASA accuracy classification for the full winding of the bushing CT whose secondary-excitation characteristic and secondary resistance are given on Fig. 3?

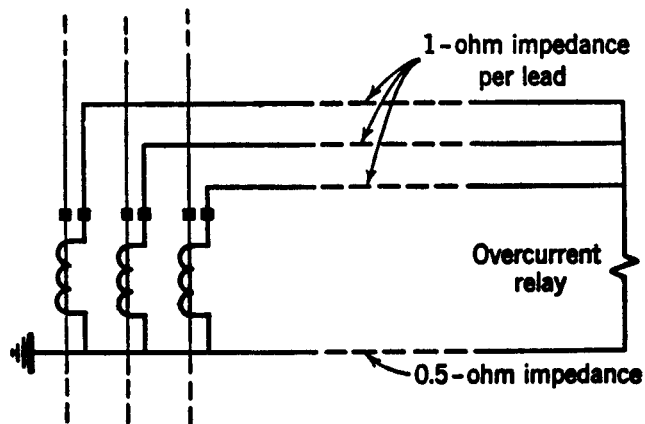

Fig. 9. Illustration for Problem 2.

2. For the overcurrent relay connected as shown in Fig. 9, determine the value of pickup current that will provide relay operation at the lowest possible value of primary current in one phase.

If the overcurrent relay has a pickup of 15 amperes, its coil impedance at 1.5 amperes is 2.4 ohms. Assume that the impedance at pickup current varies inversely as the square of pickup current, and that relays of any desired pickup are available to you.

The CT's are the same as the 20-turn tap of the CT whose secondary-excitation characteristic is shown in Fig. 3.

BIBLIOGRAPHY

1. "General Requirements for Transformers, Regulators, and Reactors," *Publ. C57.11-1948*; "American Standard Requirements, Terminology, and Test Code for Instrument Transformers," *Publ. C57.13-1954*; and "Guide for Loading and Operation of Instrument Transformers," *Publ. C57.33*, American Standards Assoc., Inc., 70 East 45th St., New York 17, N. Y.

"Application Guide for Grounding of Instrument Transformer Secondary Circuits and Cases," *Publ. 52*, American Institute of Electrical Engineers, 33 West 39th St., New York 18, N. Y.

2. *ASA C57.23*, see Reference 1.

"A Simple Method for the Determination of Bushing-Current-Transformer Characteristics," by S. D. Moreton, *AIEE Trans.*, 62 (1943), pp. 581-585. Discussions, pp. 948-952.

"A Simple Method for Determination of Ratio Error and Phase Angle in Current Transformers," by E. C. Wentz, *AIEE Trans.*, 60 (1941), pp. 949-954. Discussions, p. 1369.

3. "A Proposed Method for the Determination of Current-Transformer Errors," by G. Camilli and R. L. Ten Broeck, *AIEE Trans.*, 59 (1940), pp. 547-550. Discussions, pp. 1138-1140.

"Overcurrent Performance of Bushing-Type Current Transformers," by C. A. Woods, Jr., and S. A. Bottonari, *AIEE Trans.*, 59 (1940), pp. 554-560. Discussions, pp. 1140-1144.

"Computation of Accuracy of Current Transformers," by A. T. Sinks, *AIEE Trans.*, 59 (1940), pp. 663-668. Discussions, pp. 1252-1253.

4. *ASA C57.13*, see Reference 1.

5. "Current Transformers and Relays for High-Speed Differential Protection, with Particular Reference to Offset Transient Currents," by W. K. Sonnemann and E. C. Wentz, *AIEE Trans.*, 59 (1940), pp. 481-488. Discussions, p. 1144.

6. "Transient Characteristics of Current Transformers during Faults," by C. Concordia,, C. N. Weygandt,, and H. 3. Shott, *AIEE Trans.*, 61 (1942), pp. 280-285. Discussions, pp. 469-470

"Transient Characteristics of Current Transformers during Faults, Part II," by F. S. Rothe and C. Concordia, *AIEE Trans.*, 66 (1947), pp. 731-734.

"The Effect of Current-Transformer Residual Magnetism on Balanced-Current or Differential Relays," by H.T. Seeley, *AIEE Trans.*, 62 (1943), pp. 164-168. Discussions, p. 384.

7. "Peak Voltages Induced by Accelerated Flux Reversals in Reactor Cores Operating above Saturation Density," by Theodore Specht and E. C. Wentz, *AIEE Trans.*, 65 (1946), pp. 254-263.

"Overvoltages in Saturable Series Devices," by A. Boyajian and G. Camilli, *AIEE Trans.*, 70 (1951), pp. 1845-1851. Discussions, pp. 1952-1853.

8. "Overvoltage Protection of Current-Transformer Secondary Windings and Associated Circuits," by R. E. Kaufmann and G. Camilli, *AIEE Trans.*, 62. (1943), pp. 467-472. Discussions, pp. 919-920.
9. "The Accuracy of Current Transformers Adjacent to High-Current Busses," by R. A. Pfuntner, *AIEE Trans.*, 70 (1951), pp. 1656-1661. Discussions, p. 1662.