



HITACHI

GE Hitachi Nuclear Energy

NEDO-34175

Revision A

January 2025

*US Protective Marking: Non-Proprietary Information
UK Protective Marking: Not Protectively Marked*

BWRX-300 UK Generic Design Assessment (GDA) Chapter 12 – Radiation Protection

*Copyright 2025 GE-Hitachi Nuclear Energy Americas, LLC
All Rights Reserved*

US Protective Marking: Non-Proprietary Information
UK Protective Marking: Not Protectively Marked

NEDO-34175 Revision A

INFORMATION NOTICE

This document does not contain proprietary information and carries the notations “US Protective Marking: Non-Proprietary Information” and “UK Protective Marking: Not Protectively Marked.”

IMPORTANT NOTICE REGARDING CONTENTS OF THIS REPORT

Please Read Carefully

The design, engineering, and other information contained in this document is furnished for the purpose of obtaining the applicable Nuclear Regulatory Authority review and determination of acceptability for use for the BWRX-300 design and licensing basis information contained herein. The only undertakings of GEH with respect to information in this document are contained in the contracts between GEH and its customers or participating utilities, and nothing contained in this document shall be construed as changing those contracts. The use of this information by anyone for any purpose other than that for which it is intended is not authorized; and with respect to any unauthorized use, no representation or warranty is provided, nor any assumption of liability is to be inferred as to the completeness, accuracy, or usefulness of the information contained in this document. Furnishing this document does not convey any license, express or implied, to use any patented invention or any proprietary information of GEH, its customers or other third parties disclosed herein or any right to publish the document without prior written permission of GEH, its customers or other third parties.

UK SENSITIVE NUCLEAR INFORMATION AND US EXPORT CONTROL INFORMATION

This document does not contain any UK Sensitive Nuclear Information (SNI) subject to protection from public disclosure as described in the Nuclear Industries Security Regulations (NISR) 2003, does not contain UK Export Controlled Information (ECI), and does not contain US Export Controlled Information (ECI) subject to the export control laws and regulations of the United States, including 10 CFR Part 810.

NEDO-34175 Revision A

EXECUTIVE SUMMARY

The purpose of this Preliminary Safety Report (PSR) Chapter is to demonstrate that the BWRX-300 standard design and intended operation of the BWRX-300 will ensure that the radiation dose to workers is reduced to As Low As Reasonably Practicable (ALARP). The chapter provides information on the strategy, methods and provisions for radiation protection. The expected occupational exposures during operational states, and the measures taken to avoid and restrict exposures are described.

The chapter presents a level of detail commensurate with a 2 Step Generic Design Assessment (GDA) and is structured in line with the high-level contents of SSG-61, "Format and Content of the Safety Analysis Report for Nuclear Power Plants," (Reference 12-1).

The scope of the chapter covers:

- Outline of the approach to optimise radiation protection aligned with international guidance.
- Description of sources of radiation, both contained as well as airborne.
- Summary of design features that provide for radiation protection.
- Presentation of initial occupational dose results for main operations and associated activities.
- Key elements of a radiation protection programme.

Claims and arguments relevant to GDA step 2 objectives and scope are summarised in Appendix A, along with an ALARP position. Appendix B provides a Forward Action Plan, which includes future work commitments and recommendations for future work where 'gaps' to GDA expectations have been identified. Appendix C summarises key regulatory requirements in the UK and presents considerations with regards to addressing these.

NEDO-34175 Revision A

ACRONYMS AND ABBREVIATIONS

Acronym	Explanation
ACOP	Approved Code of Practise
ALARP	As Low As Reasonably Practicable
AOO	Anticipated Operational Occurrences
ARM	Area Radiation Monitoring Subsystem
BSL	Basic Safety Level
BSO	Basic Safety Objective
BWR	Boiling Water Reactor
CAE	Claims, Arguments, Evidence
CB	Control Building
CBA	Cost Benefit Analysis
CFD	Condensate Filters and Demineralisers System
CFR	Code of US Federal Regulations
CMon	Containment Monitoring Subsystem
CRD	Control Rod Drive
CST	Condensate Storage Tank
CUW	Reactor Water Cleanup System
DAC	Derived Air Concentration
EFS	Equipment and Floor Drain System
FMCRD	Fine Motion Control Rod Drive
FPC	Fuel Pool Cooling System
GDA	Generic Design Assessment
GEH	GE Hitachi Nuclear Energy
HCU	Hydraulic Control Unit
HSE	Health and Safety Executive
HVS	Heating Ventilation and Cooling System
HX	Heat Exchanger
IAEA	International Atomic Energy Agency
ICC	Isolation Condenser Pool Cooling and Cleanup System
ISI	Inservice Inspection
ISOE	Information System on Occupational Exposure
LWM	Liquid Waste Management System
MCA	Main Condenser and Auxiliaries System
MCR	Main Control Room
OGS	Offgas System
OPEX	Operational Experience

NEDO-34175 Revision A

Acronym	Explanation
ONR	Office for Nuclear Regulation
PREMS	Process Radiation and Environment Monitoring System
PRM	Process Radiation Monitoring System
PS	Process Sampling Subsystem
PSR	Preliminary Safety Report
PWR	Pressurised Water Reactor
RB	Reactor Building
RGP	Relevant Good Practice
RHX	Regenerative Heat Exchanger
RPV	Reactor Pressure Vessel
RWB	Radwaste Building
RWST	Refueling Water Storage Tank
SAP	Safety Assessment Principle
SCDS	Safety Case Development Strategy
SCR	Secondary Control Room
SDC	Shutdown Cooling System
SJAE	Steam Jet Air Ejector
SMR	Small Modular Reactor
SSCs	Structures, Systems, and Components
SWM	Solid Waste Management System
TB	Turbine Building
U.S.	United States
UK	United Kingdom
USNRC	United States Nuclear Regulatory Commission

NEDO-34175 Revision A

TABLE OF CONTENTS

EXECUTIVE SUMMARY	iii
ACRONYMS AND ABBREVIATIONS	iv
12 RADIATION PROTECTION.....	1
12.1 Optimisation of Protection and Safety	2
12.2 Sources of Radiation	6
12.3 Design Features for Radiation Protection	11
12.4 Dose Constraints and Dose Assessment	22
12.5 Radiation Protection Programme.....	24
12.6 References.....	51
APPENDIX A CLAIMS, ARGUMENTS AND EVIDENCE.....	53
A.1 Claims, Argument, Evidence (CAE).....	53
A.2 Risk Reduction As Low As Reasonably Practicable	54
APPENDIX B FORWARD ACTION PLAN	56
APPENDIX C UK SPECIFIC CONTEXT INFORMATION	57
C.1 Radiation Protection Principles in the UK	57
C.2 Radiation Safety Criteria in the UK	59
C.3 Consideration for Zoning	60

NEDO-34175 Revision A

LIST OF TABLES

Table 12-1: BWRX-300 Radiation Zone Definitions.....	25
Table 12-2: BWRX-300 Total Occupational Radiation Exposure Estimates	26
Table 12-3: Occupational Dose Estimate During Reactor Operations and Surveillances	27
Table 12-4: Occupational Dose Estimates During Routine Maintenance.....	28
Table 12-5: Occupational Dose Estimates During Waste Processing.....	29
Table 12-6: Occupational Dose Estimates During Refueling	30
Table 12-7: Occupational Dose Estimates During In-Service Inspection	31
Table 12-8: Occupational Dose Estimates During Special Maintenance	32
Table A-1: Radiation Protection Claims and Arguments.....	55
Table B-1: Radiation Protection Forward Action Plan Items	56
Table C-1: Radiation Safety Criteria.....	62
Table C-2: Mapping of BWRX-300 Zoning Scheme to an Example New Scheme.....	63

LIST OF FIGURES

Figure 12-1: Reactor Building Level -34.0 m Radiation Zones.....	33
Figure 12-2: Reactor Building Level -29.0 m Radiation Zones.....	34
Figure 12-3: Reactor Building Level -21.0 m Radiation Zones.....	35
Figure 12-4: Reactor Building Level -14.5 m Radiation Zones.....	36
Figure 12-5: Reactor Building Level -8.5 m Radiation Zones.....	37
Figure 12-6: Reactor Building Level -4.8 m Radiation Zones.....	38
Figure 12-7: Reactor Building Level 0.0 m Radiation Zones.....	39
Figure 12-8: Reactor Building Level 4.9 m Radiation Zones.....	40
Figure 12-9: Reactor Building Level 13.0 m Radiation Zones.....	41
Figure 12-10: Turbine Building Level 0.0 m Radiation Zones	42
Figure 12-11: Turbine Building Level 6.1 m Radiation Zones	43
Figure 12-12: Turbine Building Level 13.0 m Radiation Zones	44
Figure 12-13: Radwaste Building Level 0.0 m Radiation Zones	45
Figure 12-14: Radwaste Building Level 6.1 m Radiation Zones	46
Figure 12-15: Service Building Level 0.0 m Radiation Zones	47
Figure 12-16: Service Building Level 6.1/6.7 m Radiation Zones	48
Figure 12-17: Service Building Level 13.0 m Radiation Zones	49
Figure 12-18: Comparison of BWRX-300 Collective Dose Estimate (491 mSv/year) with ISOE Industry Operating Data.....	50

NEDO-34175 Revision A

REVISION SUMMARY

Revision #	Section Modified	Revision Summary
A	All	Initial Issuance

NEDO-34175 Revision A

12 RADIATION PROTECTION

The purpose of this Preliminary Safety Report (PSR) Chapter is to demonstrate that the BWRX-300 standard design and intended operation of the BWRX-300 will ensure that the radiation dose to workers is reduced to As Low As Reasonable Practicable (ALARP). The chapter provides information on the strategy, methods and provisions for radiation protection. The expected occupational exposures during operational states, and the measures taken to avoid and restrict exposures are described.

The chapter presents a level of detail commensurate with a 2 Step GDA and is structured in line with the high-level contents of IAEA SSG-61 (Reference 12-1).

The scope of the chapter includes the following aspects:

- Outline of the approach to optimise radiation protection aligned with international guidance. This includes the specification of key measures to minimise source terms and limit radiation levels as well as time spent in radiation areas.
- Description of sources of radiation, both contained as well as airborne.
- Summary of design features that provide for radiation protection, including facility and equipment design, materials, radiation zoning, shielding, ventilation and monitoring equipment.
- Presentation of initial occupational dose results for main operations and associated activities.
- Key elements of a radiation protection programme.

The following chapters support PSR Ch. 12 – Radiation Protection:

- PSR Ch. 3 – NEDC-34165P, “BWRX-300 UK Generic Design Assessment Ch. 3: Safety Objectives and Design Rules for Structures, Systems and Components (SSCs),” (Reference 12-2): provides an overview of the software used for conducting shielding design calculations.
- PSR Ch. 23 – NEDC-34195P, “BWRX-300 UK Generic Design Assessment Ch. 23: Reactor Chemistry,” (Reference 12-3): provides the design basis radiation concentrations in reactor water and reactor steam. The contained radiation sources presented in PSR Ch. 12 are determined by propagating the design basis coolant and steam concentrations through the BWRX-300 systems.

Claims and arguments relevant to GDA step 2 objectives and scope are summarised in Appendix A, along with an ALARP position. Appendix B provides a Forward Action Plan, which includes future work commitments and recommendations for future work where ‘gaps’ to GDA expectations have been identified. Appendix C summarises key regulatory requirements in the UK and presents considerations with regards to addressing these.

NEDO-34175 Revision A

12.1 Optimisation of Protection and Safety

The holistic As Low As Reasonably Practicable (ALARP) demonstration strategy, i.e. considering the overall risk, is presented in PSR, NEDC-34199P, "BWRX-300 UK Generic Design Assessment Ch. 27: ALARP Evaluation," (Reference 12-4), along with high level standards and guidance. This section focusses on the optimisation of the protection against the risk of radiation dose which is understood as a specific application of ALARP principles, ultimately feeding into a holistic ALARP demonstration.

12.1.1 Approach to ALARP

The BWRX-300 standard design in conjunction with administrative programs and procedures, ensure that the occupational radiation exposure to plant personnel is kept ALARP.

General design considerations and methods employed to maintain occupational radiation exposures ALARP have two main objectives:

- Reducing the necessity for and amount of personnel time spent in radiation areas
- Reducing radiation levels in routinely occupied plant areas in the vicinity of plant equipment that require personnel attention

ALARP principles have been applied during the initial BWRX-300 standard design and implemented via internal design reviews. The design is reviewed in detail for ALARP considerations and is reviewed, updated, and modified during the design phase to apply Relevant Good Practice (RGP) and Operation Experience (OPEX).

The BWRX-300 has evolved from a series of larger Boiling Water Reactor (BWR) designs over several decades. There are small BWRs with similar thermal power currently in service (Olkiluoto 1 & 2, Onagawa 1 & 2, Shika 1, etc), and there is no evidence any of those plants with compromised worker safety as a result of their smaller design. Given that the ratio of thermal power to steam flow is essentially the same for all BWRs, a smaller core generally implies smaller support systems and, as a result, a smaller footprint of the BWRX-300 standard design. Radiation protection design layout requirements (see Section 12.1.1.3 Facility Design Considerations) designed to protect workers have not been relaxed from previous designs to accommodate a smaller plant. Instead, the layout requirements are continuously reviewed to identify potential improvements using a systematic ALARP design review process and the BWRX-300 configuration management system.

In addition, the BWRX-300 design team has integrated a Reliability, Availability, Maintainability and Inspectability Program which describes the tasks that are implemented to ensure that Structures, Systems, and Components (SSCs) design, procurement, layout, maintenance, inspection and testing activities support plant and equipment reliability. Also, a Human Factors Engineering Program has been developed to identify and assess the risks and consequences that arise from human interactions with the plant at all phases of its lifecycle and to reduce those risks through the design to ALARP

During the design process, equipment and facility designs are evaluated for maintaining exposures ALARP during plant operations. Plant operations include tasks such as normal maintenance and repairs, special maintenance, refueling operations and fuel storage, Inservice Inspection (ISI), calibrations, radioactive waste handling and disposal, and equipment decommissioning activities.

The plant design integrates features such as the layout, shielding, ventilation, lighting, instrumentation, equipment selection, material control, and radiation monitoring with traffic control, security, access control, operations, maintenance, decommissioning, and health physics aspects.

NEDO-34175 Revision A

BWRX-300 standard design criteria have been established to maintain exposures ALARP and minimise radioactive contamination and facilitate decommissioning. These design criteria are tracked from identification to validation and testing. They are based on the following ALARP objectives which are consistent with the recommendations in International Atomic Energy Agency (IAEA) standards including IAEA GSG-7, GSR-5, SRS-21, SSR-2/1, SSR-2/2, NS-G-1.13, SSG-56, SSG-64:

- Minimise the generation of radioactive contamination during operation
- Minimise leaks and spills of contaminated liquids and provide containment in areas where such events might occur
- Minimise the spread of contamination, and planned movement of radioactive materials
- Provide adequate shielding from direct and scattered radiation
- Minimise time spent by workers in radiation areas and in the vicinity of radiation sources
- Reduce the need to decontaminate equipment and structures by decreasing the probability of any release, and reducing any amounts released
- Design the plant to facilitate the removal or replacement of equipment or components during facility operation or decommissioning
- Provide adequate leak detection capability to provide prompt detection of leakage from any structure, system, or component that has the potential for leakage
- Use of remote operation to reduce external exposure
- Provide adequate capability for surveillance of plant system radiation levels
- Provide appropriate decontamination facilities for personnel
- Provide adequate ventilation and filtering to control airborne radioactive materials
- Facilitate decommissioning by minimising embedded piping, sumps, or buried equipment
- Mitigate radiation exposures to workers and the public resulting from normal plant operations, Anticipated Operational Occurrences (AOO), Design Basis Accidents (DBA), and Design Extension Conditions (DEC)
- Monitor and record dose to plant workers and personnel
- Control access to radiation areas and limit the time workers occupy areas with elevated radiation levels
- Control, monitor, and mitigate radiological releases to the environment

These objectives are used to develop detailed ALARP design criteria to ensure the objectives are met. ALARP design criteria are integrated throughout the plant design. Engineers responsible for system design review and document conformance with ALARP design criteria, and each system is reviewed by engineers responsible for radiation protection.

The following sections summarise key design features to minimise source terms, time spent in radiation areas and radiation levels. These classes of features provide the top-level measures of the implemented hierarchy of control, focusing on the limitation of the dose to people by engineered means. Furthermore, a comprehensive set of radiation monitoring systems has been developed (Section 12.3.4) and control measures, such as personal protective equipment, will be used (Section 12.3). These are the key elements to satisfy RP.7

NEDO-34175 Revision A

(Hierarchy of control measured) "Safety Assessment Principles for Nuclear Facilities," (Reference 12-6).

12.1.1.1 Minimisation of Source Terms

Radiation source terms reduction design considerations:

- Minimising airborne radioactivity during refuelling includes:
 - Keeping the steam dryer, separator and chimney wet when moved and when stored during refueling to ensure attached particulate matter does not become airborne radioactivity.
 - Cooling the Reactor Building (RB) pools with large heat capacity heat exchangers
 - Sweeping the spent fuel pool surface and preventing evaporative pool losses and gases from mixing with the area atmosphere using the Fuel Pool Cooling and Cleanup System (FPC)
- Radioactive material is kept in containers to the extent possible.
- Equipment cubicles, corridors, and areas routinely occupied by operating personnel do not contain significant airborne radioactivity sources. Radioactive equipment that potentially leaks is installed in separate shielded compartments.
- Material selection minimises the creation of activated corrosion products.
- Zinc injection minimises dose rate from Co-60 deposition.

12.1.1.2 Equipment Design Considerations

Limiting Time Spent in Radiation Areas

- Passive equipment, and remotely operated process equipment and devices are used where possible.
- Equipment is designed to facilitate maintenance, minimising required time for maintenance.
- The materials selected are chosen for operating conditions to minimise maintenance.

Limiting Component Radiation Levels

- Equipment, including piping, is designed for limiting or controlling leaks by using sumps and drip pans with drains piped to the floor drains.
- The filter demineralisers in the Reactor Water Cleanup System (CUW) and FPC systems are backwashed and flushed prior to maintenance.
- Surface finishes are selected to reduce the radiation level, reduce contamination, and/or provide easy decontamination and maintenance.

12.1.1.3 Facility Design Considerations

Limiting Time Spent in Radiation Areas

- Locating equipment, instruments, and sampling stations, that require routine maintenance, calibration, operation, or inspection, for ease of access and minimum required occupancy time in radiation areas.
- Laying out plant areas allowing remote or mechanical operation, service, monitoring, or inspection of highly radioactive equipment.

NEDO-34175 Revision A

- Providing, where practicable, transportation of equipment or components requiring service to a lower radiation area.

Minimising Radiation Levels in Plant Access Areas and Vicinity of Equipment

- Separating radiation sources and occupied areas where practicable (e.g., pipes or ducts containing potentially high radioactive fluids not passing through occupied areas).
- Separating highly radioactive equipment from less radioactive equipment, instruments, and controls.
- Providing adequate shielding between radiation sources and access and service areas.
- Locating equipment, instruments, and sampling sites in the lowest practicable radiation zone.
- Providing central control panels permitting remote operation of Safety Class instrumentation and controls from the lowest radiation zone practicable.
- Providing and facilitating contamination control and service area decontamination.
- Providing space for pumps and valves outside highly radioactive areas for maintenance and inspection.
- Providing remotely operated centrifugal discharge and/or back-flushable filter systems for highly radioactive waste and cleanup systems.
- Providing labyrinth entrances to radioactive pump, equipment, and valve rooms, with adequate space in labyrinth entrances for easy access.
- Maintaining ventilation airflow patterns from areas of lower radioactivity to areas of higher radioactivity.
- Providing sufficient space and means to store and use temporary shielding wherever necessary.
- Providing adequate laydown space in equipment and component areas for dismantlement and repair, removal, and restoration of insulation as necessary for inspection or maintenance.
- Providing adequate access for transporting failed and replacement components and maintenance tools.
- Providing enough space available for the installation and use of hoisting and transport mechanisms such as cranes, hoists, monorails, hand rigging, and trolleys used during periodic inspection and maintenance.

NEDO-34175 Revision A

12.2 Sources of Radiation

This section describes the radiation sources, both contained and airborne, that provide input to the radiation protection design basis (e.g., shielding, ventilation, radwaste system design, personnel protection). At this stage of plant design, BWRX-300 source terms are based on available information; accordingly, assumptions and/or preliminary information are used, and updates are expected for future licensing stages.

The radioactive sources vary depending on operational phases or different systems and components. Consequently, the radiological impact is also phase dependent.

The radiological impact of nitrogen-16 (N-16), with 7 seconds half-life, becomes negligible a few minutes after shutdown and therefore during outages. Their contribution is significant during operation and has to be taken into account.

During the reactor's operating life, activated materials transported by the primary water may be deposited on the inner surfaces of the piping and equipment in contact with the primary water. This accumulation of contamination, especially corrosion products, is under a continuous process that depends mainly on the physical and chemical conditions of the primary system in the different reactor states. Various design features minimise such contamination.

12.2.1 Contained and Immobile Sources of Radioactive Material

The contained radiation sources provided in this section are shielding source terms which are used as the basis for the radiation protection design. The contained source term inputs to the shielding design are the maximum design basis activities that can be present in major plant components and radioactive waste management systems. Thus, where reactor water/coolant or reactor steam are used within this section, it is referring to the design basis radiation concentrations in reactor water and reactor steam, as described in PSR Ch. 23. The contained radiation sources are determined by propagating the design basis coolant and steam concentrations through the BWRX-300 systems using conservative assumptions.

12.2.1.1 Reactor Vessel Sources

The primary sources of radiation around the reactor core are:

- Neutrons and gamma rays emitted by the fission in the reactor core
- Gamma rays emitted due to the reaction between neutrons and the components inside and outside of the reactor core ((n, gamma) interactions)
- Gamma rays emitted by fission products

To determine dose external to the biological shield and within occupied areas, calculations have been conducted where the reactor core source was represented by the thermal neutron Watt Fission spectrum. This spectrum is representative of the neutron leakage expected in thermal light water reactors and was scaled by the BWRX-300 power density in the shielding calculations. The effect of (n, gamma) interactions on the reactor vessel source was considered.

Conservative assumptions made for the source model include:

- The neutron source was modelled as uniform distribution across the entire core radius. As most neutron leakage in a core of this size occurs in the peripheral of the core, the source model used is conservative.
- Full power is assumed for the entire core height conservatively bounding any axial power peaking.

NEDO-34175 Revision A

12.2.1.2 Control Rod Drive System Sources

The Control Rod Drive (CRD) System is composed of three major elements: the electro-hydraulic Fine Motion Control Rod Drive (FMCRD) mechanisms, Hydraulic Control Units (HCUs), and the CRD hydraulic subsystem. The FMCRDs provide electric motor driven positioning for normal insertion and withdrawal of the control rods and hydraulic-powered rapid insertion of control rods during abnormal operating conditions.

Historically, removal and replacement of Control Rod Drives (CRDs) is a significant contributor to occupational exposures. Improved maintainability associated with the FMCRDs design reduces personnel exposures compared to conventional BWR CRDs.

The radionuclide inventory in the CRD system for the FMCRD mechanism has been derived, 007N8600, "BWRX-300 Radioactive Sources in the Control Rod Drive System," (Reference 12-7).

12.2.1.3 Shutdown Cooling System Sources

The Shutdown Cooling System (SDC) reduces the Reactor Pressure Vessel (RPV) pressure and temperature during shutdown and provides decay heat removal capability. The radiation contained in this system is in the SDC Heat Exchanger (HX) tube side, which contains reactor coolant. There are two SDC HXs, which are located in rooms 1451 and 1461 shown on Figure 12-4. The radionuclide inventory for the SDC HXs has been derived based on the assumption that both SDC HXs are completely full, 007N9365, "BWRX-300 Reactor Water Cleanup System and Shutdown Cooling System Design Basis Source Terms," (Reference 12-8).

12.2.1.4 Fuel Pool

The Fuel Pool holds fresh and spent fuel. The gamma spectrum from a spent fuel bundle (GNF2) has been calculated as a function of time, 007N9880, "BWRX-300 Fuel Pool Gamma Source," (Reference 12-9). A high burnup of the fuel bundle was considered, which is assumed to be sufficiently conservative for the fuel pool gamma source analysis.

12.2.1.5 Fuel Pool Cooling and Cleanup System

The FPC provides cooling of the water volume in the fuel pool. Two FPC surge tanks receive inventory from the equipment pool, reactor cavity pool, and fuel pool, and inventory returning to the fuel pool is pumped through one of two trains from the surge tank through two HXs. The FPC surge tanks are located within the fuel pool wall as shown on Figure 12-8, and the FPC HXs are located in room 1556, which is shown in Figure 12-6. The radionuclide inventories for the FPC and HXs have been derived, 007N9016, "BWRX-300 Standard Plant Fuel Pool Cooling and Cleanup System and Isolation Condenser Cooling and Cleanup System Contained Source Activities," (Reference 12-10). Radiation concentrations in the fuel pool water were conservatively assumed to be 1% of the reactor water concentrations.

12.2.1.6 Isolation Condenser Cooling and Cleanup System Sources

The Isolation Condenser Pools Cooling and Cleanup System (ICC) processes water from the three Isolation Condenser inner pools and surrounding outer pools to maintain water temperature and plant water quality standards. The ICC includes two trains that transfer energy from the IC pools to the Plant Cooling Water System (PCW) via a pump and HX. The water contained in the IC pools is maintained as high-purity water, and risk of contamination of IC pool water is low. The IC pools are located in rooms 17P1 through 17P6, as shown on Figure 12-8, and the two HXs are located in room 1650, which is shown on Figure 12-7. The radionuclide inventories for the IC pools and HXs have been derived (Reference 12-10). The IC pool water was conservatively assumed to contain a small fraction ($1E-5$) of the radiation in the reactor steam.

NEDO-34175 Revision A

12.2.1.7 Reactor Water Cleanup System Sources

The Reactor Water Cleanup System provides a blowdown-type cleanup flow for the RPV during reactor power operations and directs flow to the Condensate Filters and Demineralisers System (CFD). The radioactive source in this system is from the CUW Regenerative Heat Exchanger (RHX) tube side, which contains reactor coolant concentrations, and the CUW RHX shell side, which contains CFD activities. There is a single CUW RHX which is located in room 2180 shown on Figure 12-10. The radionuclide inventory for RHX tube side and RXS shell side have been derived (Reference 12-8). The analysis assumes the CUW RHX is completely full.

12.2.1.8 Main Condenser and Auxiliaries System Sources

The Main Condenser and Auxiliaries System (MCA) is the heat sink for the steam cycle. Two Steam Jet Air Ejectors (SJAEs) maintain turbine backpressure and remove the air ingress and non-condensable gases from the main condenser. The radioactive sources in this system are from the two condenser shells during steady-state operation of the reactor, which contain reactor steam concentrations, the first and second stage SJAEs, and the SJAE intercondenser. The main condenser is shown on Figure 12-10 and Figure 12-11. The SJAEs and intercondenser are located in rooms 2150 and 2160, which are shown on Figure 12-10. The radionuclide inventories for the main condenser and the SJAE components have been derived, 008N0037, "Steam Jet Air Ejectors and Offgas System Inventory Calculation for the BWRX-300 Standard Plant," (Reference 12-11). The analysis assumes that the flow entering the main condenser is equal to the total steam flow leaving the reactor.

12.2.1.9 Offgas System Sources

The Offgas System (OGS) processes non-condensable gases from the MCA that are produced through normal power operations. The main process influent to the system is a mix of steam, air, hydrogen, and radioactive noble gases from the MCA SJAE. The objective of the OGS is to process this influent prior to release to the environment to reduce the release of gaseous radionuclides to maintain the exposure of persons in unrestricted areas to radioactive effluents ALARP. The radioactive sources in the OGS are from the recombiner, which consists of a preheater section, recombiner section, and condenser section, the cooler condenser, moisture separator, two dryers, and four charcoal tanks. The recombiner, cooler condenser, moisture separator, and dryers are located in room 2181, which is shown on Figure 12-10. The four charcoal tanks are located in room 4100, which is shown on Figure 12-13. The radionuclide inventories for the OGS equipment have been derived (Reference 12-11).

12.2.1.10 Equipment and Floor Drain System Sources

The Equipment and Floor Drain System (EFS) collects liquid waste streams generated in the BWRX-300 power block and transfers these wastes to the appropriate disposal or collection system. The radioactive sources in this system are from sumps within Containment, the RB, the Radwaste Building (RWB), and the Turbine Building (TB). The EFS Containment Sump is in room 1100A, which is shown in Figure 12-1. The RB, RWB, and TB sumps are located at the elevations shown in Figure 12-1, Figure 12-13, and Figure 12-10. The radionuclide inventories for these sumps have been derived, 007N9302, "BWRX-300 Standard Plant Liquid Waste Management System Contained Source Activity," (Reference 12-12). The analysis assumes a single sump is collecting fluid within each building (and a single pressurised sump within containment), providing a conservative estimate as the inventory for a single sump is to be applied for all sumps located in the same building.

NEDO-34175 Revision A

12.2.1.11 Liquid Waste Management System Sources

The Liquid Waste Management System (LWM) reclaims, treats, and stores treated water from waste streams for use by other plant systems. The contaminated influent streams are fed to the LWM from the EFS sumps. The radioactive sources in this system are from the following components:

- Two LWM Collection Tanks - contain activities from the EFS sumps from containment, RB, TB, and RWB, and overboard flow from CUW/SDC
- LWM Sample Tanks A & B - contain activities from the LWM Collection Tanks after processing through filter skid and from overboard flow from CUW/SDC
- The LWM Condensate Storage Tank (CST) - contain activities from the LWM Sample Tanks A & B
- The LWM Refueling Water Storage Tank (RWST) - contains activities from the reactor cavity pool during pool drain down for refueling and overboard flow from CUW/SDC
- LWM Filter Skid Resin - contains activities from the two LWM collection tanks

The two collection tanks and two sample tanks are located in room 4171, which is shown on Figure 12-13. The CST and RWST are located in room 2183, which is shown on Figure 12-10. The radionuclide inventories for these LWM components have been derived (Reference 12-12).

12.2.1.12 Solid Waste Management System Sources

The Solid Waste Management System (SWM) processes, packages, and temporarily stores solid waste prior to shipment offsite. The significant contaminated influent streams are fed to the SWM from the LWM, the FPC, and the CFD. The accumulated radioactive sources in this system are from the spent resin tank, which contains activities from the LWM filter skid resin and the FPC and CFD demineraliser resins, and the two sludge tanks, which contain activities from the LWM RWST filter sludge, the FPC filter skid sludge, and the CFD filter sludge. The single spent resin tank and two sludge tanks are located in rooms 4180, 4150, and 4160, which are shown on Figure 12-13. The radionuclide inventories for these tanks have been derived, 008N0133, "BWRX-300 Solid Waste Management System Contained Source Activity," (Reference 12-13).

12.2.2 Sources of Airborne Radioactive Material

12.2.2.1 Reactor Building

Sources of airborne activity in the RB include:

- Evaporation of fuel pool water containing low levels of radiation that becomes airborne on the operating deck. The fuel pool water does not contain noble gases, and there is no process equipment in the fuel handling area and operating deck.
- Leakage from process systems located in the lower levels of the RB. Process equipment in the RB lower levels include the SDC and the FPC. The normal flow into the SDC is single phase reactor coolant and does not include reactor steam or noble gases. Because the fuel pool contains no noble gases, there are none in the FPC. There is no other reactor coolant process equipment in the lower levels of the RB.

The RB upper-level area consisting of the fuel handling area and operating deck are provided with filtered once-through supply air from two 100% operating Air Handling Units. The fuel handling area and operating deck are essentially one air volume extending from the containment top slab to the RB roof. Accordingly, rooms serviced by these air handling units are considered collectively as the upper level of the RB for calculating airborne radiation

NEDO-34175 Revision A

activity, 007N9701, "BWRX-300 Standard Plant Reactor Building Airborne Radioactivity for Normal Operation," (Reference 12-14).

The RB lower levels are provided with filtered once-through supply air from one of two operating air handling units. The airspace in the rooms on each RB lower level are connected through doors and passageways, and the RB levels in the lower RB are connected through stairwells, elevator shafts, and pipe/utility chases. Therefore, the lower levels are collectively treated as a single compartment for calculating airborne radiation activity (Reference 12-14).

The airborne concentrations for the RB upper level and the RB lower levels have been derived and demonstrated to be under the Derived Air Concentration (DAC) limits established in 10 Code of Federal Regulations (CFR), "Title 10," Parts 1 to 50, (Reference 12-5) and Part 20, Appendix B, Table 1, Column 3 (Reference 12-14).

12.2.2.2 Radwaste Building

Sources of airborne activity in the RWB include:

- As RWB tanks are filled from the top, splashing may occur, and entrained radioactivity could become airborne. This activity is not released directly into the atmosphere in the rooms; however, a small amount of leakage may occur.
- RWB pumps and valve leakage

RWB Ventilation is provided by two 50% capacity supply air handling units and two 50% capacity exhaust air handling units. Clean filtered outside air is supplied through ductwork to the RWB lobby and lab, pressurising those areas. The exhaust air handling units take suction on the potentially contaminated tank and pump rooms, creating negative pressures in those spaces, resulting in air transferring from clean to potentially contaminated areas. The airspace in the rooms on each RWB level is connected through doors, passageways, and pipe/utility chases. Therefore, the separate levels and rooms are collectively treated as a single compartment for calculating airborne radiation activity, 007N9666, "BWRX-300 Standard Plant Radwaste Building Airborne Radioactivity for Normal Operation," (Reference 12-15).

The airborne concentrations for the RWB have been derived (Reference 12-15), and it is noted that they are under the DAC limits established in 10 CFR (Reference 12-5) Part 20, Appendix B, Table 1, Column 3.

12.2.2.3 Turbine Building

Sources of airborne activity in the TB include process leakage of steam and liquid in the turbine building.

The airborne concentrations for the TB have been derived, 007N7860, "BWRX-300 Standard Plant Turbine Building Airborne Radioactivity Concentrations During Normal Operations," (Reference 12-16), and it is noted that they are under the DAC limits established in 10 CFR (Reference 12-5) Part 20, Appendix B, Table 1, Column 3.

NEDO-34175 Revision A

12.3 Design Features for Radiation Protection

This section describes the design features for radiation protection of specific radioactive components such as equipment and piping, and the BWRX-300 standard design. The radiation protection features discussed here have been designed based on GEH BWR OPEX. The BWRX-300 standard design ALARP requirements, 006N5081, "BWRX-300 As Low as Reasonably Achievable Design Criteria for Standard Design," (Reference 12-17) incorporate the guidance within the NS-G-1.13, "Radiation Protection Aspects of Design for Nuclear Power Plants," (Reference 12-18).

Specific design and control considerations have been identified and listed based on the hierarchy of controls, i.e. Eliminate, Reduce, Isolate, Control, Personal protective equipment, and Discipline.

12.3.1 Facility and Equipment Design Features

This section describes several specific equipment components, as well as BWRX-300 standard design features that support keeping the exposure of plant workers during operation and maintenance ALARP.

12.3.1.1 Equipment Specific Features:

Tanks

- The overflow pipes of the tanks that hold radioactive liquid are connected to the appropriate radioactive drain collection system, and the vents run to the building's ventilation exhaust system, but neither is hard connected to their respective drain or vent systems to prevent the uncontrolled transport of contamination through those systems.
- Non-corrosion-resistant material tanks that contain radioactive material have a corrosion resistant lining.
- Walls or bunds are provided around the tank to collect leaks. Room collection capacity is sufficient to contain the maximum amount of liquid for which the tank is designed.
- Bottom valves on slurry containing tanks are flush mounted to eliminate pockets.

Heat Exchangers in Radioactive Service

- Tube and shell heat exchangers are designed with an excess of tubes to accommodating tube plugging, when necessary.
- Heat exchanger drains are provided and are hard piped to floor drains. An air gap is provided at the connection of the drain lines and floor drains to prevent backflow.
- Heat exchanger design allows for drainage of fluids from the exchanger and avoid pooling that could lead to radioactive crud deposition.
- Cleaning connections are provided for condensate, demineralised water, and/or chemical solutions, as necessary.

Piping

- Piping is selected to provide a service life equivalent to the design life of the plant, with consideration given to corrosion allowances and environmental conditions.
- Contaminated piping systems are welded to the extent possible.
- Backing rings or consumable inserts are not used for systems that contain highly radioactive fluids or that contain high solids content (i.e., spent resin or filter sludge).
- The piping, where possible, is constructed of seamless pipe as a means to reduce radioactivity accumulation on seams.

NEDO-34175 Revision A

- Radioactive piping is sized to produce turbulent flow to maintain solids suspension without plugging.
- Drains and flushing provisions are employed as necessary to reduce the effect of “dead legs” and low points.
- Systems that contain multiple pumps generally are designed with pumps in separate alcoves with piping routed into shielded pipe chases as necessary.
- Radioactive piping is run in a manner that minimises radiation exposure to plant personnel. This involves radioactive pipe routing in corridors being minimised. For situations in which radioactive piping are routed through corridors or other low radiation areas, an analysis is conducted to ensure this routing does not compromise the existing radiation zoning.
 - Piping that may contain post-accident radiation sources is not routed in access routes, including stairways, hallways, and are not routed through emergency evacuation routes.
 - Use of shielded pipe trenches and pipe chases, where routing of high-activity pipes in low-level areas cannot be avoided.
 - Separating radioactive and non-radioactive pipes for maintenance purposes.
 - The arrangement of piping incorporates safety division separation, logical grouping of components within a system, system operability, and maintenance access requirements.
 - Lines for non-radioactive systems are not run inside biologically shielded compartments except where needed to supply services inside the compartment.
 - Piping configurations are designed to minimise the number of “dead legs” and low points to avoid accumulation of radioactive crud and fluids in the line.
- Provisions are made in radioactive systems for venting and flushing with condensate or chemical cleaning agents to reduce crud buildup.
- A distinction is made between piping conveying radioactive and non-radioactive fluids, and separate routing through shielded pipe chases is provided whenever possible.
- Piping in radioactive systems such as the CUW, SDC, and FPC systems are butt-welded connections, rather than socket welds, to reduce crud traps.
- Contaminated piping is cleanable or removable for decommissioning.
- Where piping penetrates through walls (e.g., pipe runs with short sections), the designs minimise the use of embedded piping to the extent possible to facilitate the dismantlement of the systems and the decommissioning of the facility.
- When radioactive and non-radioactive pipes are co-located, drain provisions are provided for removing radioactive fluids, and the valves are remotely controlled.
- Penetrations for piping through shield walls are designed to minimise shine on surrounding areas.

NEDO-34175 Revision A

- Underground piping is not installed unless it is only used for clean service. Otherwise, it is either enclosed within a guard pipe and monitored for leakage, or accessible for visual inspections via a trench or tunnel. Threaded and flanged connections are kept to a minimum. Other joints are welded or otherwise permanently bonded depending on the piping material.

Ion Exchange and Activated Carbon Beds and Filters

- Filters in purification and cleaning systems are operated and cleaned remotely.
- For purification systems, the preparation and changing of resins or removal of activated carbon is performed remotely.

Pumps and Valves

- Pumps located in radiation areas are designed to minimise the time required for maintenance.
- Where two or more pumps containing highly radioactive fluids are located adjacent to each other, shielding is provided between them to maintain exposure levels ALARP.
- Pumps adjacent to other highly radioactive equipment (e.g., radwaste system) are also shielded to reduce the maintenance exposure.
- Pump control instrumentation for process equipment is located outside high radiation areas in separate alcoves, and motor or pneumatic-operated valves or valve extension stems are employed to allow operation from these areas.
- Operation of the pumps and associated valves for radioactive systems is accomplished remotely through reach rods or electric controls.
- Pump casing drains are provided on radioactive systems whenever possible to remove fluids from the pump prior to disassembly. Pump drains are piped to the radioactive drain system.
- Applications where valves with packing are used have cartridge-type packing that can be easily replaced, otherwise valves without packing are utilised, like diaphragm valves or quarter-turn ball valves.
- Instrumentation and valves in shielded cubicles are remotely operable to the maximum extent possible to reduce the need for entering these high radiation areas.
- Straight-through valve configurations are selected where practical, over those that exhibit flow discontinuities or internal crevices to minimise crud trapping.
- Wherever possible, valves in systems containing radioactive fluids are separated from those for “clean” services to reduce the radiation exposure from adjacent valves and piping during maintenance.
- Remotely operated valves are employed in high radiation areas, whenever possible, to minimise the need for entering these areas, otherwise provisions are available to remove the source term before the valves are operated.
- Resources are provided for flushing the valves in radioactive systems, in order to reduce exposure to personnel during maintenance.
- Safety and relief valves and depressurisation valves are designed with flange connections to allow whole valve removal or reinstallation.
- Back seat valves are used wherever possible to reduce leaks through the packing when the valve is fully open. Pipe insulation around valves is easily removable.

NEDO-34175 Revision A

Radioactive Drains

- For systems containing highly radioactive fluids, drains that are used frequently are hard piped to the appropriate drain. An air gap shall exist between the system drain and the floor or equipment drain hub to prevent backflow.
- Sump vents are located near the room exhaust vent register to control airborne radioactivity released from discharges to the sump.
- Sumps are stainless steel or stainless steel lined to reduce corrosion and to provide easily decontaminated surfaces
- To the extent possible, drain lines are sloped to ensure that they adequately drain by gravity.
- Drain lines having a potential for containing highly radioactive fluids are routed through pipe chases or shielded cubicles.
- Floor drains are one piece to minimise possibility of liquid penetrating at embedment boundaries. Non-porous alternatives to grout such as epoxy is considered for the installation of floor drains.
- Drain lines contain traps to prevent the flow of radioactive gas from compartment to compartment through the drain system.
- The drains from rooms that house spent resin tanks, phase separator tanks, or demineraliser vessels are equipped with normally closed isolation valves.
- Sumps are located at the lowest level of the buildings.

Sludge and Resin Systems

- System design and implementation prevent accumulating and retention of radioactive sludge and resins in transfer pipes. For this purpose:
 - The length of the pipe runs is reduced as much as possible.
 - Low points and blind sections are avoided.
 - The flow, as far as possible, is by gravity, so lines are designed with the appropriate slope.
 - Flow restrictions in the pipes are avoided.

12.3.1.2 Material Selection:

- Material selection minimises the creation of corrosion products with the potential to be activated to the extent possible.
- The reactor coolant system materials are selected to prevent the formation of corrosion products. Non-stainless-steel equipment has an adequate finish and is protected with a non-corrosive material to aid in decontamination.
- Pipes are designed for a 60-year life, based on the environmental conditions and corrosion in order to prevent maintenance, unless documented otherwise. Pipes with less than a 60-year life are replaceable (i.e., not embedded in concrete).
- For systems in contact with reactor coolant (e.g., pumps, valves), component materials are as degradation mechanism resistant as possible. Degradation mechanisms (e.g., stress corrosion, thermal aging, embrittlement, fatigue, thermal fatigue) are considered jointly during the material selection process:
 - Reactor internal components, except for the zircaloy in the reactor core, are stress corrosion-resistant stainless steels or other high alloy steels.

NEDO-34175 Revision A

- System components and component joints and seals are made of materials that are qualified to withstand the pressure, temperature, and radiation to which they are subject and thus minimise maintenance.
- Heat exchangers are constructed of stainless steel or titanium tubes to minimise the possibility of failure and reduce maintenance requirements.
- Materials in contact with reactor coolant and subject to significant wear, corrosion, erosion, or neutron activation, except the fuel assemblies, use the lowest cobalt content available with a target cobalt content of 0.02 weight percent or less for stainless steel or nickel base alloys, and with no stainless steel or nickel base alloys exceeding a cobalt content of 0.05 weight percent:
 - Carbon steel used in systems processing or storing reactor coolant or steam is low in nickel content and contains only very small amounts of cobalt impurity.
 - Main condenser tubes and closed loop cooling heat exchangers (tubes and their tube sheets) are made of low-cobalt stainless steel or titanium alloys.
 - The BWRX-300 is designed to limit the use of cobalt-bearing materials on moving components that have historically been identified as major sources of reactor coolant contamination. Stellite is typically used for hard facing of components that are extremely wear resistant. Use of high cobalt alloys such as Stellite is restricted to those applications where no satisfactory alternative material is available.

12.3.1.3 Layout and Access:

The layout of the BWRX-300 is designed to meet the ALARP design considerations described in Section 12.1.1. The plant layout is shown on Figure 12-1 through Figure 12-17. Structures are designed to provide adequate shielding, as described in Section 12.3.2. The layout uses both distance and shielding to reduce potential dose rates in work locations, and areas are identified by radiation zones, as described in Section 2.3.1.4 Radiation and Contamination Zoning.

Facility layout is consistent with the following design features:

- From the point of view of radiological protection, the layout follows the concept of separation into three different and isolable areas: uncontrolled access areas, controlled (limited) access areas, and inaccessible areas. Table 12-1 further defines the different plant areas.
- The controlled access areas encompass all radioactive systems, equipment, components, and materials.
- The routes between buildings of the controlled (limited) access area and their accessible rooms are as short as possible, designed for an easy passage, and are run through low radiation areas.
- Rooms that need to be accessed are reached easily from the service corridors.
- The floor-ceiling height of accessible areas are adequate for comfortable passage of personnel and the necessary tools for inspections and maintenance.
- There are areas for storing removable elements and mobile shielding that do not hinder personnel passage and mobility.
- The areas of the plant are arranged in such a way that service operations, monitoring or inspection of highly radioactive equipment can be carried out manually or remotely.

NEDO-34175 Revision A

- Access to High Radiation Areas is suitably signposted and blocked by physical barriers.
- Access to enclosures is sized to enable the entry and exit of the necessary components and tools.
- Equipment, instruments, and sampling stations that require routine maintenance, calibration, operation, or inspection, are located for ease of access and minimum required occupancy time in radiation areas.
- Plant areas are laid out to allow remote or mechanical operation, service, monitoring, or inspection of highly radioactive equipment.
- Where possible, transportation equipment is provided (e.g., monorails, carts, hoists) to lower radiation areas for equipment or components requiring service.
- Means to control contamination and to facilitate decontamination of potentially contaminated areas are provided where practicable.
- Exposure of personnel during inspection and maintenance is minimised by locating equipment and instrumentation as far as possible from potential sources of high radiation.
- Penetrations through outer walls of the building containing radiation sources are sealed to prevent leaks into the environment.
- Appropriately sloped floor drains are provided in shielded cubicles and other areas where the potential for a spill exists to limit the extent of contamination.
- Doors are installed, as necessary, to prevent open passage to High Radiation Areas.
- Doors have the appropriate radiation area signs and locks to prevent inadvertent access to high radiation rooms.
- The paint and finish of room walls, floors, staircases, and platforms are easy to decontaminate. The paint provides a non-porous surface.
- Access is controlled to the 'controlled and limited access' radiation zones (zones G through I) including the use of lockable doors and interlocks, and monitoring of personnel and materials at the access and egress points.

12.3.1.4 Radiation and Contamination Zoning:

BWRX-300 radiation zones are established and assigned based on:

1. Expected frequency of access, and
2. Estimated relative source strengths in the various plant rooms.

The radiation zone classification scheme is shown in Table 12-1 (Reference 12-17). The radiation area, high radiation area, and very high radiation area designations are assigned in accordance with the thresholds defined in 10 CFR 20.1003 (Reference 12-5).

Operating activities, inspection requirements of equipment, maintenance activities, and abnormal operating conditions were considered in determining the appropriate zoning for a given area. The radiation zones established for the BWRX-300 plant are shown in Figure 12-1 through Figure 12-17. The zones are used as shielding requirements.

The dose rate applicable for a particular zone is based on OPEX and represents design dose rates in a particular zone. BWR plants have been operating for several decades, and OPEX with similar design basis numbers shows that only a small fraction of the permissible dose is received from radiation sources controlled by equipment layout, or the structural shielding

NEDO-34175 Revision A

provided. Accordingly, the dose rates for a particular zone should not be interpreted as the expected dose rates that apply in all portions of that zone, or for all types of work within that zone, or at all periods of entry into the zone.

12.3.2 Shielding

The permanent shielding analysis is completed during the detailed design phase. The evaluations identify those areas experiencing elevated dose rates during power and shutdown conditions and are not mitigated by structure or component design or location. The anticipated dose rates and frequency of access are included in the shielding analyses. Using these results and system interaction and structural/component loading analyses, permanent shielding is installed in target areas/components. Permanent shielding is preferred to temporary shielding.

12.3.2.1 Shielding Design Method:

The primary objective of radiation shielding is protecting operating personnel and the general public from radiation emanating from the reactor, the power conversion systems, the radwaste process systems, and the auxiliary systems, while maintaining appropriate access for operation and maintenance. Source terms in various pieces of plant equipment are discussed in Section 12.2. Shutdown conditions, such as fuel transfer operation, as well as accident conditions are considered in designing shielding for the plant. Systems containing radioactivity are identified and shielded based on access and exposure level requirements of surrounding areas. The radiation zone areas described in Section 2.3.1.4 Radiation and Contamination Zoning indicate design radiation levels where equipment shielding contributes to achieving the dose rate in the area (i.e., radiation zones are shielding requirements).

The shielding requirements in the plant perform the following functions:

- Limit the general public, plant personnel, contractor, and visitor exposure ALARP and within regulatory limits.
- Limit critical components radiation exposure within specified radiation tolerances assuring component performance and design life are not impaired.

The source terms used in the shielding calculations are analysed conservatively. Transient conditions, shut-down, and normal operating conditions are used ensuring a conservative source is used in the analysis. Shielding is based on design basis fission product concentrations in the coolant in addition to activation products. For components where N-16 is the major radiation source, a concentration based upon BWR fleet operating plant data is used.

The mathematical models used to represent a radiation source, associated equipment and shielding are established to ensure conservative calculation results. Depending on the versatility of the applicable computer program, various degrees of complexity for the actual physical situation are incorporated. Suitable conservatism is included in the calculations.

An overview of the software used for conducting shielding design calculations is provided in PSR Ch. 3.

12.3.2.2 Shielding Design Criteria:

Consistent with Section 12.1.1, design criteria are used in establishing the BWRX-300 shielding design to meet ALARP objectives.

- Containment – The major shielding structures consist of the containment walls and reactor shield wall (bioshield):
 - The BWRX-300 standard design provides biological shielding of appropriate composition and thickness in order to protect operational personnel during DBAs and DECs.

NEDO-34175 Revision A

- The containment outer wall is a reinforced concrete cylinder of steel plate composite modules with diaphragm plates, of appropriate thickness, that totally surrounds containment. A reinforced concrete top slab, of appropriate thickness, covers containment.
 - The shielding for the RB is designed to maintain the dose rates shown in Figure 12-1 through Figure 12-9.
 - The design includes necessary shielding provisions in the upper containment in order to reduce the dose ALARP during transfer of irradiated spent fuel assemblies.
 - The design includes applicable shielding provisions to minimise dose rates in case of a fuel handling mishap resulting in dropping a fuel assembly across the reactor flange.
- Containment penetrations shall be designed to ensure streaming of radiation from containment through the penetrations do not increase the radiation zones in rooms outside of containment. This shall be accomplished by keeping the number of penetrations to a minimum, locating penetrations above the heads of plant personnel in frequently occupied areas, configuring penetrations to prevent line-of-sight streaming, minimising the area and number of straight-through paths containing material of very low density (e.g. gases, including air), use of shadow shields, use of shield plugs, and/or shielding penetrations using a modified high density silicone elastomer (or equivalent) absorber..
 - The dose rate in the Main Control Room (MCR), is limited to 2 $\mu\text{Sv/hr}$ (0.2 mrem/hr) during normal reactor operating and shutdown conditions. The dose rates for the Secondary Control Room (SCR) are shown on Figure 12-5. The outer walls of the Control Building (CB) are designed to attenuate radiation from radioactive materials contained within the RB and from possible airborne radiation in the environment surrounding the CB following an accident.
 - Processing equipment is located as far as possible from personnel dwelling and passage areas minimising shielding. When required to meet ALARP objectives, shielded labyrinths are used to eliminate radiation streaming through access ways from sources located in cubicles.
 - Penetrations through shield walls are shielded reducing radiation streaming through the penetrations.
 - Wherever possible, radioactive piping is run in a manner minimising plant personnel radiation exposure that includes:
 - Minimising radioactive pipe routing in corridors
 - Avoiding routing high-activity pipes through low-radiation zones
 - Using shielded pipe trenches and pipe chases where routing of high-activity pipes in low-level areas cannot be avoided
 - Separating radioactive and non-radioactive pipes for maintenance
 - Maintaining acceptable levels at valve stations by using motor-operated or diaphragm valves. Minimising worker radiation exposure by providing draining and flushing provisions in the valve design. Operator shielding is provided for manual valve applications using shield walls or valve stem extensions.
 - Shielding is provided for the MCR to mitigate plant personnel exposure resulting from radiation sources in containment following an accident.

NEDO-34175 Revision A

- Provisions are made for shielding major radiation sources during ISI to reduce personnel exposure. Steel platforms are provided for ISI of the RPV nozzle welds and associated piping.
- The primary material used for shielding is concrete. Where special circumstances dictate, steel, lead, water, a modified high density silicone elastomer, or a boron-laced refractory material is used.

12.3.2.3 Shielding Design Basis:

An overview of the key shielding assessments will be developed as part of the Forward Action Plan (APPENDIX B).

12.3.3 Ventilation

Consistent with Section 12.1.1, design criteria are used in establishing the BWRX-300 Heating Ventilation and Cooling System (HVS) design to meet ALARP objectives and for personnel protection:

- HVS for the fuel pool minimises airborne radioactivity by sweeping the pool surface and preventing evaporative pool losses and gases from mixing with the area atmosphere.
- The HVS limits the extent of airborne contamination by providing airflow patterns from areas of low contamination to more contaminated areas by using an appropriate negative pressure differential.
- The HVS service in contaminated areas of the BWRX-300 plant conditions and circulates air through the contaminated areas of the buildings in a once-through fashion. Flow is generally directed from the corridors (point of highest pressure) to the equipment alcove rooms, then to the rooms themselves, then to the air ducts, and finally to the exhaust ductwork.
- The passage of ventilation ducts through walls and structures does not significantly reduce the efficiency of the shielding. HVS duct penetrations used for exhaust are routed above personnel head height to minimise personnel exposure by streaming effects. HVS duct penetrations are not located in line of sight between radiation sources and occupied areas.
- Buildings that contain radioactive materials are equipped with radiological monitoring connections (sample ports) in the exhaust ductwork prior to the combined installed monitoring instrumentation as a means to target radiological system leakages.
- Fume hoods or similar devices are installed in laboratories, sampling rooms and component decontamination rooms.
- HVS filters that are expected to become highly contaminated are shielded from one another and from areas that are accessible by personnel, with the shielding specified to minimise their exposure during maintenance.

12.3.4 Monitoring of Individuals and Working Areas

The Process Radiation and Environmental Monitoring System (PREMS) provides monitoring for both general area radiation and process and effluent streams to ensure that radiation and effluent exposures are ALARP and within regulatory limits. The PREMS consists of four subsystems:

- Area Radiation Monitoring Subsystem (ARM)
- Containment Monitoring Subsystem (CMon)

NEDO-34175 Revision A

- Process Radiation Monitoring Subsystem (PRM)
- Process Sampling Subsystem (PS)

Fixed area radiation monitoring is described within the sections below and is provided by the ARM and the CMon.

The BWRX-300 standard design has low levels of airborne radiation. Monitoring of airborne radiation inside the facility is accomplished with periodic grab sampling using portable air monitors, and when necessary, bioassay.

12.3.4.1 Area Radiation Monitoring Subsystem

The ARM measures the gamma radiation levels at assigned locations within the plant, displays the measurements in the MCR, and initiates an MCR alarm, SCR alarm, and a local alarm (both visual and audible) when the radiation level exceeds a preset limit. Area radiation monitors are placed at key locations throughout the plant, where they can continuously monitor and assess gamma exposure conditions. The ARM subsystem monitors area radiation levels on the refueling floor and are located in the RB, TB, RWB, CB, and service building.

The following criteria are considered for detector placement:

- Areas which require entry or exit, or both, that are normally or occasionally accessible which may experience significant increases in exposure rates.
- Areas that are most likely to be occupied.
- Areas where structural materials or equipment do not cause inadvertent shielding of the detector, ensuring accurate monitor response to increases in exposure rates.
- Environmental conditions, including the range of temperature, pressure, and humidity are considered for the areas where the detector, or electronics, or both are located.
- Placement in easy-access and uncluttered areas, such that minimal use of equipment is required to service the monitor and to allow for proper calibration.

The ranges of the area radiation monitors are selected based on expected exposure rates and radiation sources present. The following criteria are considered in selecting monitor ranges:

- The lowest expected exposure rate, and the desirability of monitoring such rate.
- The expected exposure rate under normal operating conditions.
- The expected maximum exposure rate under AOOs.
- The upper end of the scale is sufficiently high to have an on-scale reading for exposure rates up to ten times the expected maximum rate.
- If using two channels to obtain a wide measurement range, their ranges overlap by at least one decade.

12.3.4.2 Containment Monitoring Subsystem

The CMon monitors containment pressure, temperature, water level, hydrogen concentration, oxygen concentration, fission products, and area radiation levels. Real-time measurements are displayed in the MCR with alarms to notify personnel when measurements exceed preset limits. Local indication and alarms are provided where necessary to notify personnel of hazardous conditions. Only the portion of CMon that monitors for fission products and radiation levels in containment is described here.

The criteria for the placement of the CMon area radiation monitors are the same as for ARM, with two additional criteria applied:

- Provide a reasonable assessment of area radiation conditions inside containment.

NEDO-34175 Revision A

- The monitors are widely separated so as to provide independent measurements and monitor a large fraction of the containment volume.

The range for monitors within containment provides a reasonable assessment of area radiation conditions inside containment. The monitoring range is determined as design information about environmental conditions are developed.

The fission product monitoring function of CMon is supported by two independent skids that measure particulate, iodine and noble gas and that are located outside containment. Samples are physically extracted from the containment atmosphere, analysed, and returned to containment. Each skid includes three independent analysers (particulate, iodine, and noble gas), flow extraction/control equipment, grab sampling taps, a local control panel, and audible/visible alarms. Filters and grab samples are periodically collected from the skids for isotopic analysis.

12.3.4.3 Process Radiation Monitoring Subsystem

The PRM samples and monitors airborne contamination at the stack, in OGS streams, and in the ventilation exhaust from the RB, RWB, and TB. Portable air samplers are used to check for airborne radioactivity in work areas prior to entry where radiation levels could exceed allowable limits. Detectors in the PRM subsystem provide measurement indication of airborne radiological conditions from occupied areas.

12.3.4.4 Process Sampling Subsystem

The PS collects liquid and gaseous samples for analysis. This analytical information is used to monitor plant and equipment performance. This process subsequently informs plant operations if changes to operating parameters are necessary in order to meet acceptance criteria or statutory environmental limits. Continuous samples are diverted to continuous monitoring equipment that transmits data to the plant computer. Alarms indicate off-normal conditions.

NEDO-34175 Revision A

12.4 Dose Constraints and Dose Assessment

This section describes the assessment of estimated occupational dose for the BWRX-300 plant during normal operations, 007N3183, "Annual Occupational Collective Radiation Dose for BWRX-300," (Reference 12-19), which is a significant element in supporting the BWRX-300 standard design and methods of operation to ensure occupational radiation exposures are ALARP.

The estimated annual occupational exposures are considered for six activity categories:

- Radioactive waste handling
- Normal maintenance
- Special (unscheduled) maintenance
- Refueling
- In-service inspection (ISI)
- Operation and surveillances

The dose assessment is dependent on estimates for dose rates in various occupied areas, frequency of operations, and person-hours for the activities in the six dose assessment categories. The estimates for these variables are developed using a variety of available methods including BWRX-300 radiation zoning levels, available technical reports, experiential data based on previous and current BWR plant designs and operational information, and the current expectations for operations, maintenance, waste processing, refueling and ISI activities for the BWRX-300 standard design. The major differences between the BWRX-300 standard design and the BWR designs supplying the information that comprises the technical bases for this assessment are the size of the reactor, the plant system configuration, and the plant arrangement. No credit has been taken for reduced staffing, classification of components, surveillance/inspection requirements, and other design features. The collective worker doses reported therefore are high confidence upper boundary estimates expected based on the current conceptual design, and future design iterations are expected to establish a basis to reduce the estimate.

Airborne radiation in the BWRX-300 is controlled to negligible levels during normal operation of the facility (see Section 12.2.2), so the dose from airborne activity is not a significant contributor to the total collective dose. As such, the estimated collective doses in this assessment do not assume contributions from inhalation or airborne radioactivity.

The dose assessment calculates specific doses for workers performing activities in areas of the facility with a dose rate $\geq 1 \mu\text{Sv/hr}$ and sums those task specific doses to determine the total annual collective occupational dose estimate for normal operation of the plant in each of the six dose assessment categories. The task-specific collective doses are calculated as the product of (a) the estimated effective dose rates where the activities are performed multiplied by (b) the collective person-hours/year estimates required to complete them. The results for the six dose assessment categories are shown in Table 12-2 to Table 12-8.

The collective dose estimate gives an indication of the radiological conditions at a plant and are, therefore, often used by plant operators and regulators to assess the overall performance of the plant operation in relation to radiation protection. Industry occupational exposure data is extracted from the Nuclear Energy Agency Information System on Occupational Exposure (ISOE), "Occupational Exposures at Nuclear Power Plants," (Reference 12-20) and compared to the BWRX-300 collective worker dose estimate in Figure 12-18.

The ISOE database gathers occupational exposure information for 501 units, covering over 88% of the world's operating commercial power reactors. The ISOE BWR values shown in Figure 12-18 represent the calculated global averages of annual collective dose considering

NEDO-34175 Revision A

data from Finland, Germany, Japan, Mexico, Spain, Sweden, Switzerland, and the United States (U.S.) over a ten year period from 2009 to 2019.

The BWRX-300 worker dose estimate of 491 mSv/year, albeit conservative, is significantly lower than the average collective worker doses reported at operating BWR reactors over the most recent reporting period (2009 to 2019) and is slightly lower than the average collective worker doses reported in Pressurised Water Reactors (PWRs) over that period. When relaxations such as credit for remote operations of process equipment or lower dose rates based on calculations are applied, the BWRX-300 annual estimate will likely be lower than the average collective worker doses observed at operating BWR, PWR, and CANDU reactors. It is noted that there should be no expectation that worker doses at BWRs are proportional to power. However, certain critical worker exposure contributors related to reactor power such as the amount of fuel, and the quantity of radioactive waste do significantly lower the worker doses for the BWRX-300.

NEDO-34175 Revision A

12.5 Radiation Protection Programme

The Radiation Protection Program consists of a series of procedures and programs that keep radiation exposure to workers and the public ALARP. It includes the following key elements, as per Reference 12-1:

- Radiation protection organisation, oversight, and administration
- Training and qualifications
- Process and procedures
- Radiation zones classification
- Program measures to limit exposure and dose
- Equipment and instrumentation
- Contamination control
- Emergency planning

NEDO-34175 Revision A

Table 12-1: BWRX-300 Radiation Zone Definitions

Zone	Dose Rate	Stay Time Limit	Description	Zone Class
A	≤ 6 μSv/h (0.6 mrem/h)	None	Uncontrolled and unlimited access	Not a Radiation Area
B	≤ 10 μSv/h (1 mrem/h)	None	Controlled and unlimited access	
C	≤ 50 μSv/h (5 mrem/h)	20 h/wk	Controlled and limited access	Limited Access Area
D	≤ 250 μSv/h (25 mrem/h)	4 h/wk	Controlled and limited access	Radiation Area
E	≤ 1000 μSv/h (100 mrem/h)	1 h/wk	Controlled and limited access	
F	≤ 10 mSv/h (1 rem/h)	5 h/year	Controlled and limited access with special authorisation permit required	
G	≤ 100 mSv/h (10 rem/h)	30 min/year	Controlled and limited access with special authorisation permit required	High Radiation Area
H	≤ 1000 mSv/h (100 rem/h)	Limited	Controlled and limited access with special authorisation permit required	
I	≤ 5000 mSv/h (500 rem/h)	Limited	Controlled and limited access with special authorisation permit required	
J	> 5000 mSv/h (500 rem/h)	No access	Inaccessible	Very High Radiation Area

NEDO-34175 Revision A

Table 12-2: BWRX-300 Total Occupational Radiation Exposure Estimates

Activity	Estimated Collective Hours Annually (person-hours/year)	Projected Annual Collective Dose (person-mSv/year)	Percent of Total Collective Dose (%)
Reactor Operations and Surveillances	2,609	38	7.8
Routine Maintenance	7,085	90	18.2
Waste Processing	2,456	60	12.1
Refueling	2,580	47	9.6
ISI	759	32	6.4
Special Maintenance	11,624	225	45.8
Total	27,113	491	100.0

NEDO-34175 Revision A

Table 12-3: Occupational Dose Estimate During Reactor Operations and Surveillances

Facility Area / Activity	Estimated Average Dose Rate ($\mu\text{Sv/hr}$)	Estimated Collective Exposure Time (person-hours/year)	Collective Dose (person-mSv/year)
Reactor Building			
Routine Operation, Chemistry, Health Physics and Security Surveillance	8	1095	8.8
FMCRD HCU Surveillance	50	15	0.8
CUW Piping Surveillance	150	10	1.5
SDC Surveillance	150	30	4.5
Passive Systems Surveillance	30	125	3.8
Instrumentation and Control Surveillance and Testing	8	125	1.0
Outside Steam Tunnel	30	61	1.8
Nonroutine Clean-up and Decontamination	30	96	2.9
Routine Operating Deck/Pool Surveillances	8	122	1.0
Fuel Receipt, Processing, and Channeling	8	108	0.9
FPC Surveillances	150	12	1.8
Nonroutine Fuel Sipping	30	80	2.4
Radwaste Building			
Included in Table 12-5 estimate			
Turbine Building			
Routine Operation, Chemistry, Health Physics and Security Surveillance	10	730	7.3
Total		2609	38.3

NEDO-34175 Revision A

Table 12-4: Occupational Dose Estimates During Routine Maintenance

Facility Area / Activity	Estimated Average Dose Rate ($\mu\text{Sv/hr}$)	Estimated Collective Exposure Time (person-hours/year)	Collective Dose (person-mSv/year)
Reactor Building			
SDC Pipes/Valves	150	50	7.5
SDC Pumps/Motors	150	50	7.5
FMCRD HCU's	30	40	1.2
Passive System Valves (Isolation Condenser System (ICS))	30	50	1.2
Passive System Pools (ICS)	30	50	1.5
Instrumentation	30	150	4.5
FPC Filters/Demineralisers	150	60	9.0
FPC Pumps/Motors	30	75	2.3
FPC Valves	30	80	2.4
Fuel Pool, Fuel Racks, Fuel Casks	30	100	3.0
Radwaste Building			
Reverse Osmosis	150	75	11.3
Demineralisers	150	40	6.0
Tanks	150	100	15.0
Pumps	30	20	0.6
Valves	30	35	1.1
Instrumentation	30	60	1.8
Turbine Building			
CUW HX/Pipes/Valves	150	50	7.5
Miscellaneous TB Work in Accessible Areas	1	6000	6.0
Total		7085	89.6

NEDO-34175 Revision A

Table 12-5: Occupational Dose Estimates During Waste Processing

Facility Area / Activity	Estimated Average Dose Rate ($\mu\text{Sv/hr}$)	Estimated Collective Exposure Time (person-hours/year)	Collective Dose (person-mSv/year)
Radwaste Building			
LWM / SWM, and Lab Operation	10	2080	20.8
Dry Active Waste Sorting/Processing	50	48	2.4
High Integrity Container Processing/Shipments	50	80	4.0
Dry Active Waste Shipments	50	48	2.4
Miscellaneous Activities (e.g. valve lineup, filter changes)	150	200	30.0
Total		2456	59.6

NEDO-34175 Revision A

Table 12-6: Occupational Dose Estimates During Refueling

Facility Area / Activity	Estimated Average Dose Rate ($\mu\text{Sv/hr}$)	Estimated Collective Exposure Time (person-hours/year)	Collective Dose (person-mSv/year)
Reactor Building			
Containment and RPV Disassembly/Reassembly	15	740	11.1
Phase I Refueling ¹	25	440	11.0
Phase II Refueling ²	25	900	22.5
Fuel transfer to Independent Fuel Storage Facility (if utilised)	5	500	2.5
Total		2580	47.1

Notes:

1. Phase I of the refueling process includes removal of fuel from the core, in-vessel inspection and maintenance of reactor components, and potential replacement of core components.
2. Phase II of the refueling process includes reloading the in-vessel maintenance fuel offload, loading new fuel assemblies, and shuffling of the core assemblies to complete the refueling and maintenance outage fuel transfer.

NEDO-34175 Revision A

Table 12-7: Occupational Dose Estimates During In-Service Inspection

Facility Area / Activity	Estimated Average Dose Rate ($\mu\text{Sv/hr}$)	Estimated Collective Exposure Time (person-hours/year)	Collective Dose (person-mSv/year)
Primary Containment			
General Activities	60	100	6.0
RPV Welds/Nozzles	60	100	6.0
Main Steam piping/valves	60	15	0.9
Feedwater piping/valves	60	15	0.9
CUW piping/valves	60	5	0.3
SDC piping/valves	60	12	0.7
Other Equipment (Passive systems)	60	50	3.0
Reactor Building			
General Activities	30	300	9.0
SDC	30	75	2.3
Boron Injection System piping and valves	30	25	0.8
FMCRD	30	12	0.4
Other Equipment (Passive systems)	30	50	1.5
Total		759	31.7

NEDO-34175 Revision A

Table 12-8: Occupational Dose Estimates During Special Maintenance

Facility Area / Activity	Estimated Average Dose Rate (μSv/hr)	Estimated Collective Exposure Time (person-hours/year)	Collective Dose (person-mSv/year)
Primary Containment			
Containment Isolation Valves Rework	18	1000	18.0
FMCRD Under Vessel	65	200	13.0
LPRMs/GTs	100	24	2.4
Miscellaneous Valves & Pumps	40	750	30.0
Miscellaneous Instrumentation	50	250	12.5
Other Outage Maintenance Including Passive Systems	50	650	32.5
Reactor Building			
RIV Rework	13	650	8.5
SDC Pumps/Motors	150	100	15.0
FMCRD HCU	30	150	4.5
FMCRD Rebuild	30	240	7.2
Instrumentation	8	300	2.4
Condensate Treatment	35	500	17.5
Other Outage Maintenance Including Passive Systems	8	1700	13.6
Turbine Building			
Major Turbine Overhaul	3	4200	12.6
Turbine Valves/Pumps	39	910	35.5
Total		11624	225.1

NEDO-34175 Revision A

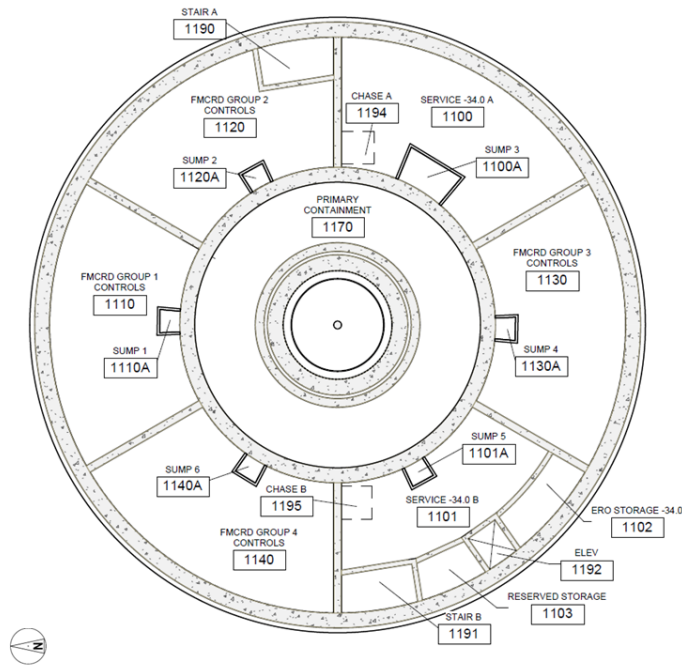

Radiation Zones Level -34.0m

ROOM	DESCRIPTION	FULL POWER	SHUTDOWN
1100	SERVICE -34.0 A	B	A
1101	SERVICE -34.0 B	B	A
1102	STORAGE -34.0	B	A
1103	RESERVED STORAGE	B	A
1110	FMCRD GROUP 1 CONTROLS	B	A
1120	FMCRD GROUP 2 CONTROLS	B	A
1130	FMCRD GROUP 3 CONTROLS	B	A
1140	FMCRD GROUP 4 CONTROLS	B	A
1170	PRIMARY CONTAINMENT	J	G
1190	STAIR A	B	A
1191	STAIR B	B	A
1192	ELEVATOR	B	A
1194	CHASE A*	Unoccupied/Controlled Access	
1195	CHASE B*	Unoccupied/Controlled Access	
1100A	SUMP 3	D	C
1101A	SUMP 5	D	C
1110A	SUMP 1	D	C
1120A	SUMP 2	D	C
1130A	SUMP 4	D	C
1140A	SUMP 6	D	C

* Access to the chases requires an explicit authorization permit

Figure 12-1: Reactor Building Level -34.0 m Radiation Zones

NEDO-34175 Revision A

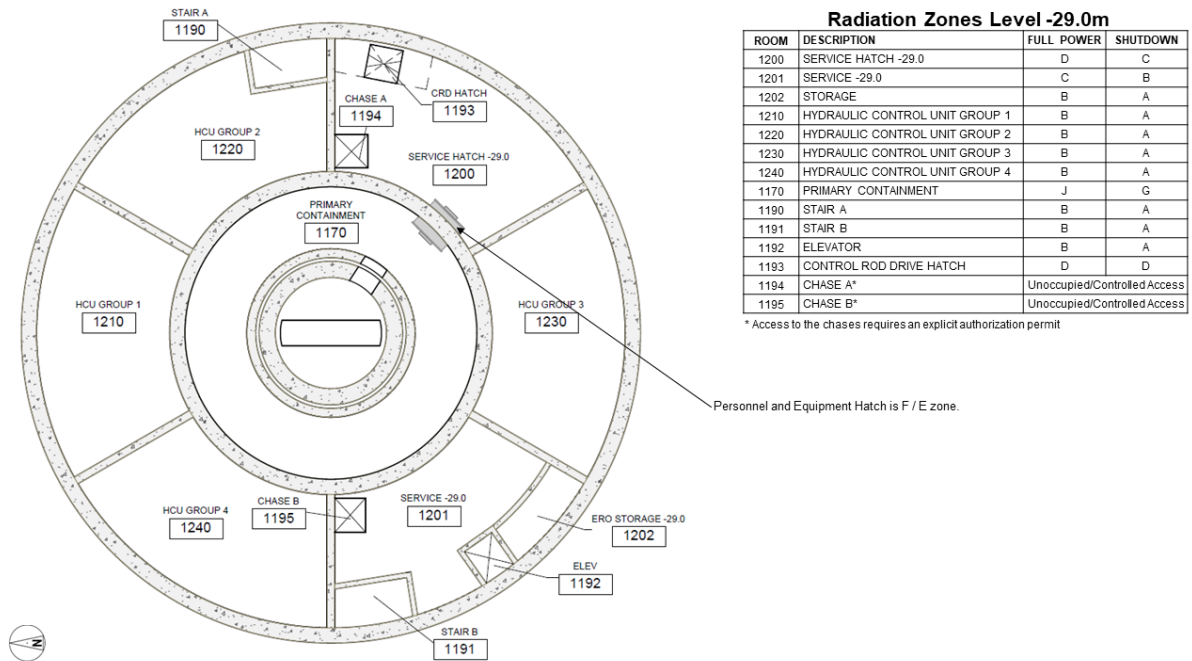
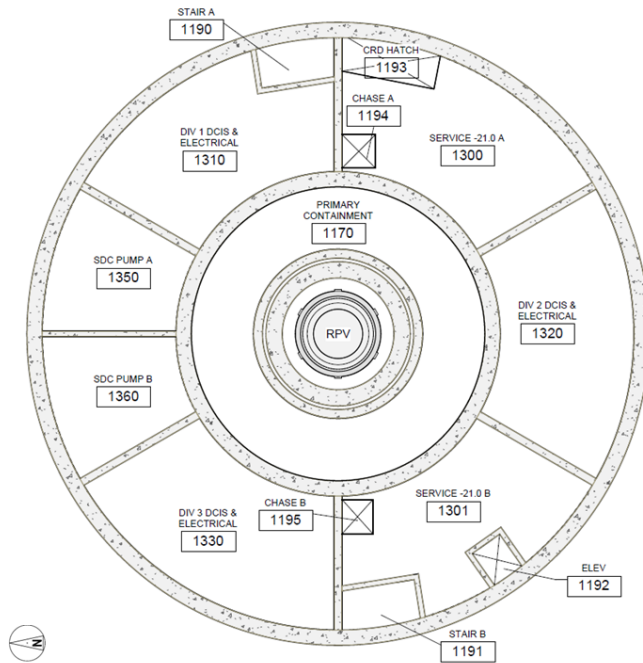

Figure 12-2: Reactor Building Level -29.0 m Radiation Zones

NEDO-34175 Revision A



Radiation Zones Level -21.0m

ROOM	DESCRIPTION	FULL POWER	SHUTDOWN
1300	SERVICE -21.0 A	B	A
1301	SERVICE -21.0 B	B	A
1310	DIV. 1 DCIS & ELECTRICAL	B	A
1320	DIV. 2 DCIS & ELECTRICAL	B	A
1330	DIV. 3 DCIS & ELECTRICAL	B	A
1350	SHUTDOWN COOLING PUMP A	C	E
1360	SHUTDOWN COOLING PUMP B	C	E
1170	PRIMARY CONTAINMENT	J	G
1190	STAIR A	B	A
1191	STAIR B	B	A
1192	ELEVATOR	B	A
1193	CONTROL ROD DRIVE HATCH	C	D
1194	CHASE A*	Unoccupied/Controlled Access	
1195	CHASE B*	Unoccupied/Controlled Access	

* Access to the chases requires an explicit authorization permit

Figure 12-3: Reactor Building Level -21.0 m Radiation Zones

NEDO-34175 Revision A

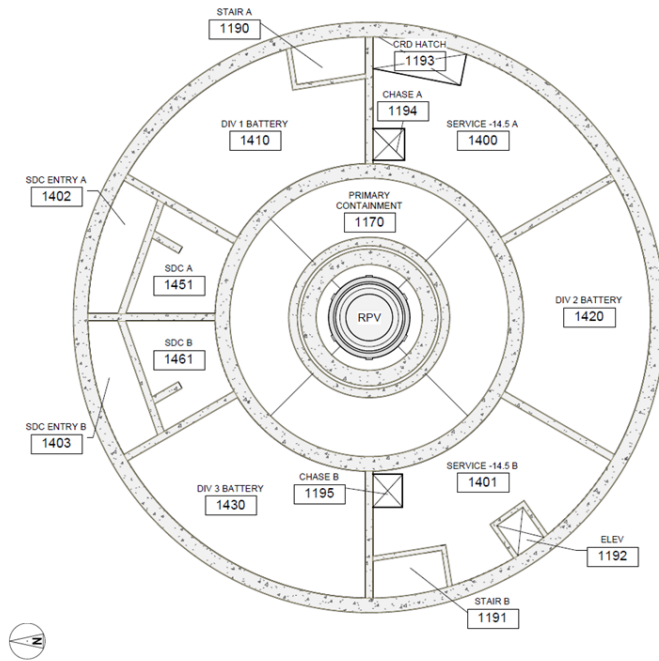

Radiation Zones Level -14.5m

ROOM	DESCRIPTION	FULL POWER	SHUTDOWN
1400	SERVICE -14.5 A	B	A
1401	SERVICE -14.5 B	B	A
1402	SHUTDOWN COOLING ENTRY A	B	C
1403	SHUTDOWN COOLING ENTRY B	B	C
1410	DIVISION 1 BATTERY ROOM	B	A
1420	DIVISION 2 BATTERY ROOM	B	A
1430	DIVISION 3 BATTERY ROOM	B	A
1451	SHUTDOWN COOLING A	C	F
1461	SHUTDOWN COOLING B	C	F
1170	PRIMARY CONTAINMENT	J	G
1190	STAIR A	B	A
1191	STAIR B	B	A
1192	ELEVATOR	B	A
1193	CONTROL ROD DRIVE HATCH	C	D
1194	CHASE A*	Unoccupied/Controlled Access	
1195	CHASE B*	Unoccupied/Controlled Access	

* Access to the chases requires an explicit authorization permit

Figure 12-4: Reactor Building Level -14.5 m Radiation Zones

NEDO-34175 Revision A

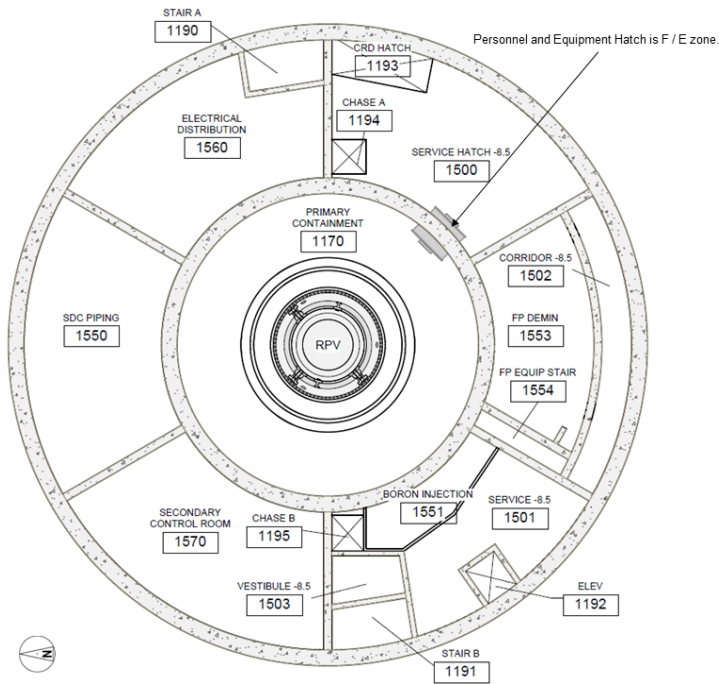

Radiation Zones Level -8.5m

ROOM	DESCRIPTION	FULL POWER	SHUTDOWN
1500	SERVICE HATCH -8.5	D	C
1501	SERVICE -8.5	B	A
1502	CORRIDOR -8.5	B	A
1503	VESTIBULE -8.5	B	A
1550	SHUTDOWN COOLING PIPING	D	E
1551	BORON INJECTION	B	A
1553	FUEL POOL DEMIN	D	D
1554	FUEL POOL EQUIP STAIR	C	C
1560	ELECTRICAL DISTRIBUTION	B	A
1570	SECONDARY CONTROL ROOM	B	A
1170	PRIMARY CONTAINMENT	J	F
1190	STAIR A	B	A
1191	STAIR B	B	A
1192	ELEVATOR	B	A
1193	CONTROL ROD DRIVE HATCH	D	D
1194	CHASE A*	Unoccupied/Controlled Access	
1195	CHASE B*	Unoccupied/Controlled Access	

* Access to the chases requires an explicit authorization permit

Figure 12-5: Reactor Building Level -8.5 m Radiation Zones

NEDO-34175 Revision A

Radiation Zones Level -4.8m

ROOM	DESCRIPTION	FULL POWER	SHUTDOWN
1556	FUEL POOL EQUIP MEZZANINE	E	E

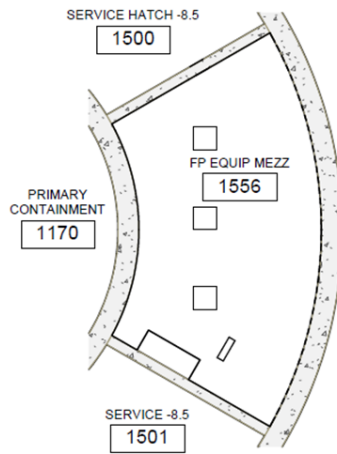
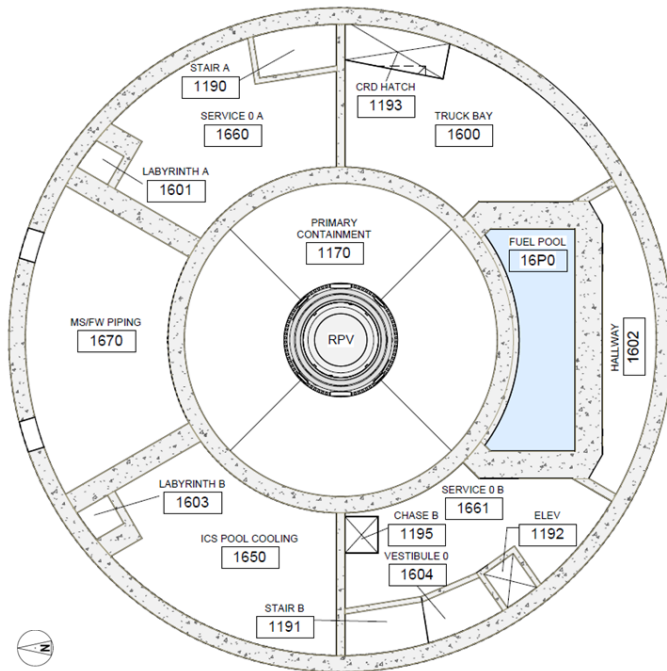

Figure 12-6: Reactor Building Level -4.8 m Radiation Zones

NEDO-34175 Revision A



Radiation Zones Level 0m

ROOM	DESCRIPTION	FULL POWER	SHUTDOWN
1600	TRUCK BAY	B	A
1601	LABYRINTH A	F	C
1602	HALLWAY	B	A
1603	LABYRINTH B	F	C
1604	VESTIBULE 0	B	A
1650	ICS POOL COOLING	D	C
1660	SERVICES 0 A	B	A
1661	SERVICES 0 B	B	A
1670	MAIN STEAM/FEEDWATER PIPING	H	C
16P0	FUEL POOL	I	I
1170	PRIMARY CONTAINMENT	I	F
1190	STAIR A	B	A
1191	STAIR B	B	A
1192	ELEVATOR	B	A
1193	CONTROL ROD DRIVE HATCH	C	D
1195	CHASE B*	Unoccupied/No Radiation Zone	

* Access to the chases requires an explicit authorization permit

Figure 12-7: Reactor Building Level 0.0 m Radiation Zones

NEDO-34175 Revision A

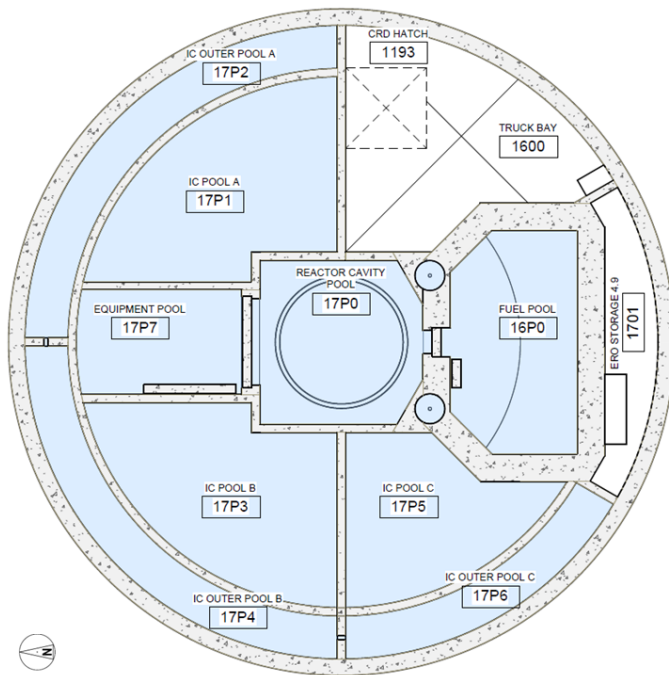

Radiation Zones Level 4.9m

ROOM	DESCRIPTION	FULL POWER	SHUTDOWN
1600	TRUCK BAY	B	A
1701	STORAGE 4.9	B	A
16P0	FUEL POOL**	I	I
17P0	REACTOR CAVITY POOL	J	F
17P1	ISOLATION CONDENSER POOL A	C	C
17P2	ISOLATION CONDENSER OUTER POOL A	B	B
17P3	ISOLATION CONDENSER POOL B	C	C
17P4	ISOLATION CONDENSER OUTER POOL B	B	B
17P5	ISOLATION CONDENSER POOL C	C	C
17P6	ISOLATION CONDENSER OUTER POOL C	B	B
17P7	EQUIPMENT POOL**	C	D
1193	CONTROL ROD DRIVE HATCH	C	D

** Zone J during spent fuel transfers

Figure 12-8: Reactor Building Level 4.9 m Radiation Zones

NEDO-34175 Revision A

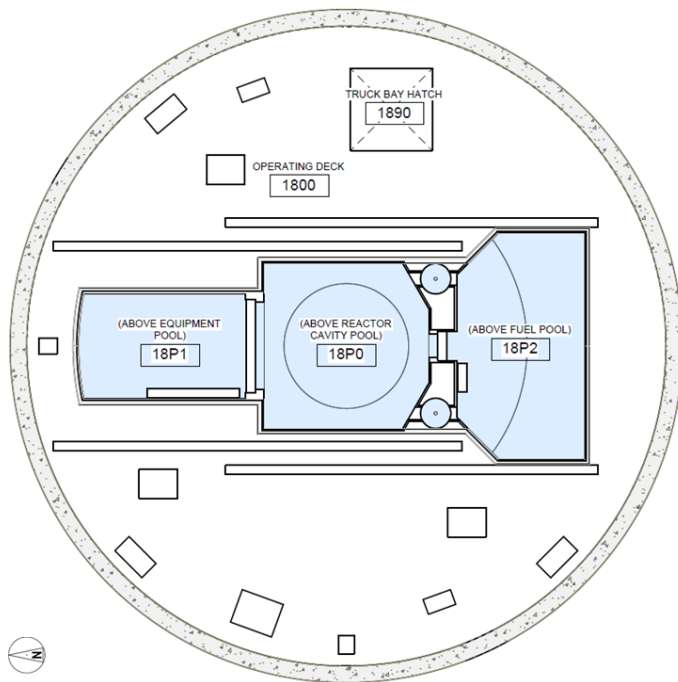

Radiation Zones Level 13.0m

ROOM	DESCRIPTION	FULL POWER	SHUTDOWN
1800	OPERATING DECK*	C	B
1890	TRUCK BAY HATCH*	C	B
18P0	(ABOVE REACTOR CAVITY POOL)*	C	B
18P1	(ABOVE EQUIPMENT POOL)**	C	B
18P2	(ABOVE REFUEL POOL)*	C	B

* Zone E during transfers of spent fuel or high activity components.
 ** Zone E in the presence of the vessel head

Figure 12-9: Reactor Building Level 13.0 m Radiation Zones

NEDO-34175 Revision A

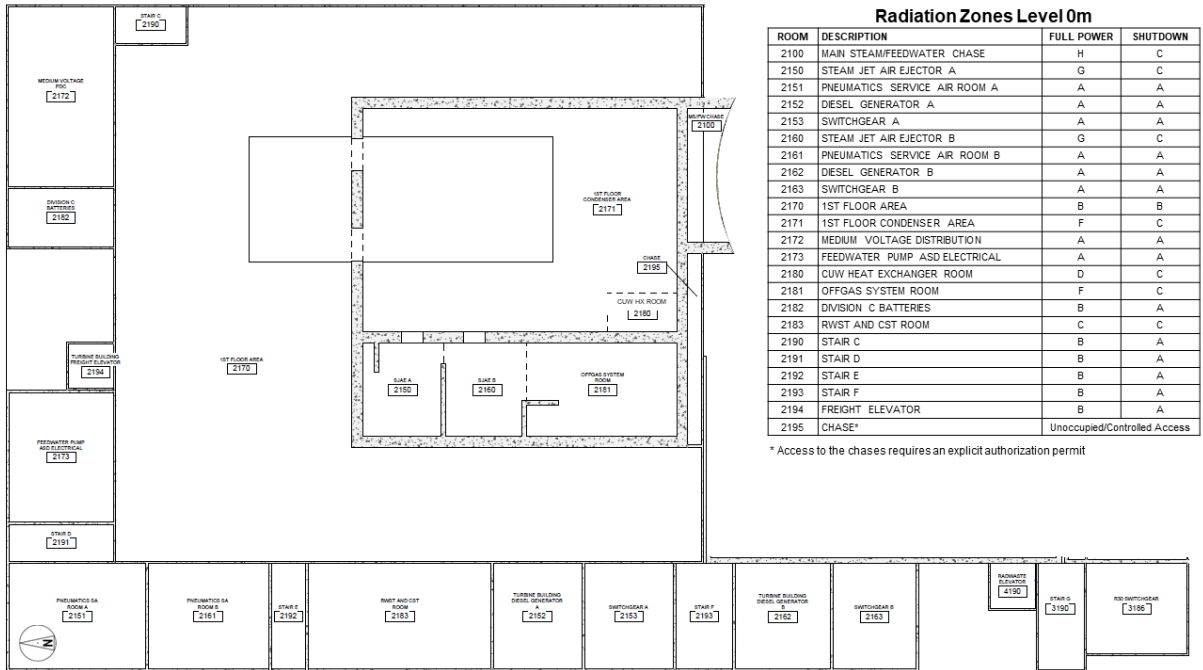
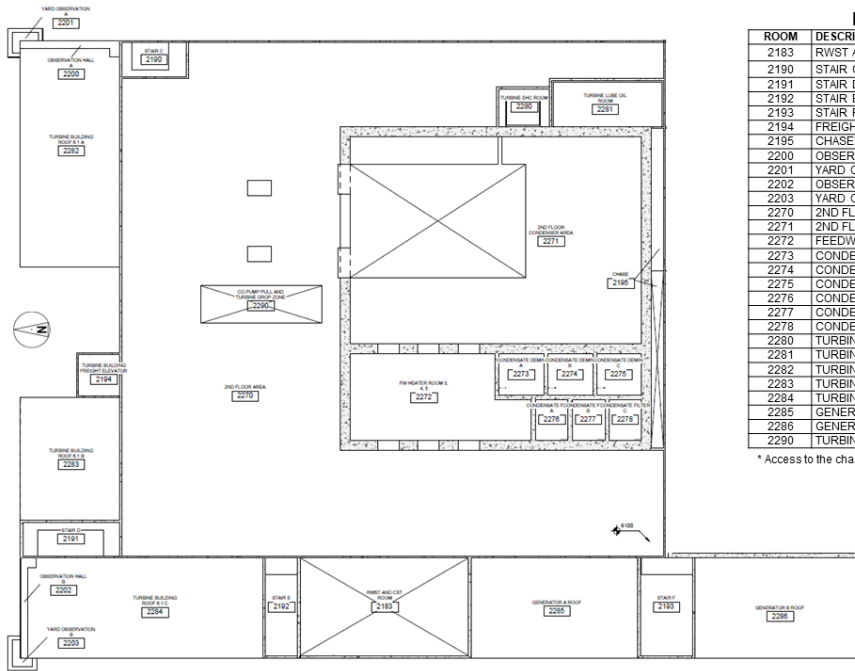

Figure 12-10: Turbine Building Level 0.0 m Radiation Zones

NEDO-34175 Revision A



Radiation Zones Level 6.1m

ROOM	DESCRIPTION	FULL POWER	SHUTDOWN
2183	RWST AND CST ROOM	C	C
2190	STAIR C	B	A
2191	STAIR D	B	A
2192	STAIR E	B	A
2193	STAIR F	B	A
2194	FREIGHT ELEVATOR	B	A
2195	CHASE*	Unoccupied/Controlled Access	
2200	OBSERVATION HALL A	B	A
2201	YARD OBSERVATION A	B	A
2202	OBSERVATION HALL B	B	A
2203	YARD OBSERVATION B	B	A
2270	2ND FLOOR AREA	B	B
2271	2ND FLOOR CONDENSER AREA	F	C
2272	FEEDWATER HEATER ROOM	G	C
2273	CONDENSATE DEMIN A	G	G
2274	CONDENSATE DEMIN B	G	G
2275	CONDENSATE DEMIN C	G	G
2276	CONDENSATE FILTER A	E	E
2277	CONDENSATE FILTER B	E	E
2278	CONDENSATE FILTER C	E	E
2280	TURBINE EHC ROOM	C	C
2281	TURBINE LUBE OIL ROOM	C	C
2282	TURBINE BUILDING ROOF 6.1 A	Unoccupied/Controlled Access	
2283	TURBINE BUILDING ROOF 6.1 B	Unoccupied/Controlled Access	
2284	TURBINE BUILDING ROOF 6.1 C	Unoccupied/Controlled Access	
2285	GENERATOR A ROOF	Unoccupied/Controlled Access	
2286	GENERATOR B ROOF	Unoccupied/Controlled Access	
2290	TURBINE DROP ZONE	B	B

* Access to the chases requires an explicit authorization permit

Figure 12-11: Turbine Building Level 6.1 m Radiation Zones

NEDO-34175 Revision A

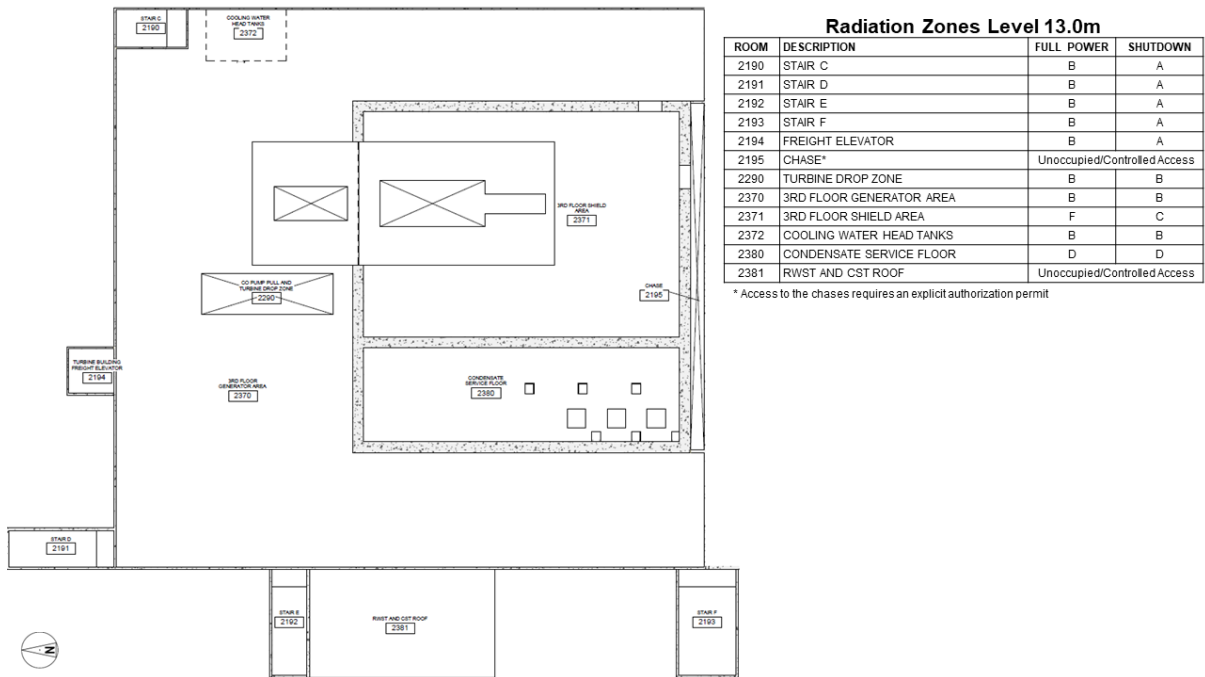

Figure 12-12: Turbine Building Level 13.0 m Radiation Zones

NEDO-34175 Revision A

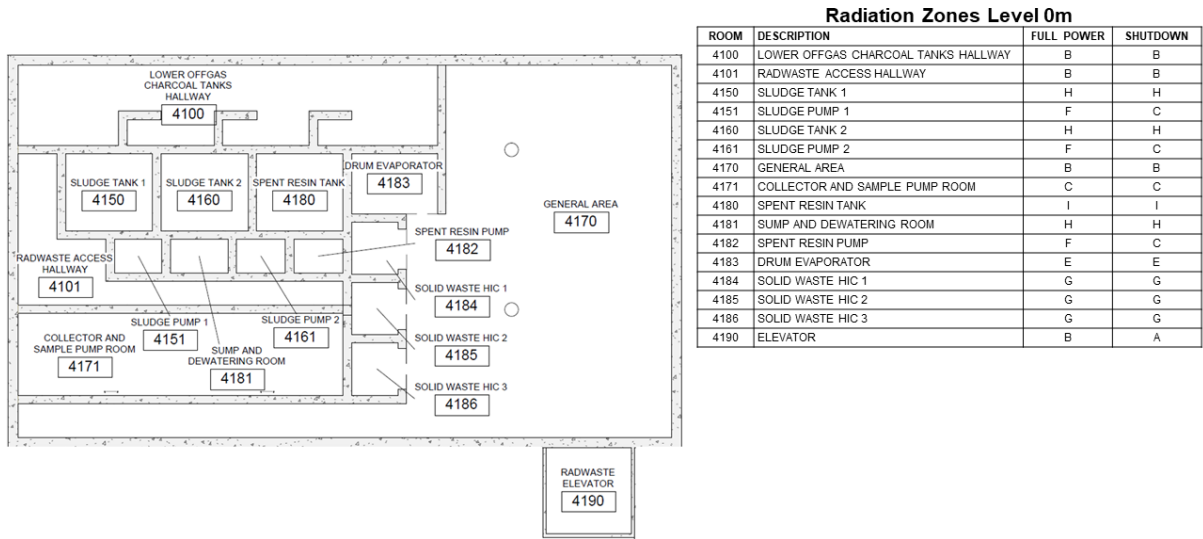

Figure 12-13: Radwaste Building Level 0.0 m Radiation Zones

NEDO-34175 Revision A

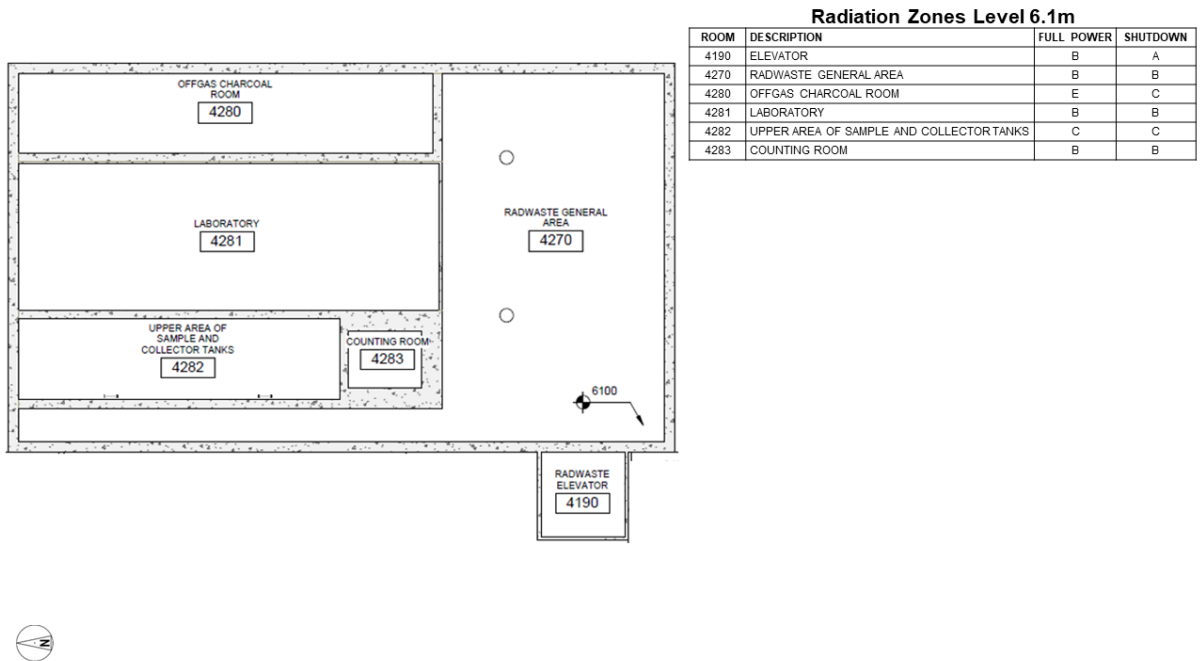

Figure 12-14: Radwaste Building Level 6.1 m Radiation Zones

NEDO-34175 Revision A

Radiation Zones Level 0m

ROOM	DESCRIPTION	FULL POWER	SHUTDOWN
5101	TURBINE BUILDING ACCESS ARC	B	B
5102	FUEL AND REFUELING OUTAGE ACCESS ARC	B	B
5103	CONTROL BUILDING ACCESS ARC	B	B
5104	REACTOR BUILDING EGRESS PATHWAY	B	B
5105	RADWASTE BUILDING ACCESS ARC	B	B

Radiation Zones Level 0m

ROOM	DESCRIPTION	FULL POWER	SHUTDOWN
5180	NEW FUEL / REFUELING OUTAGE STAGING	B	B
5190	STAIR H	A	A
5191	ELEVATOR	A	A
5192	STAIR I	B	A
5193	STAIR J	B	A

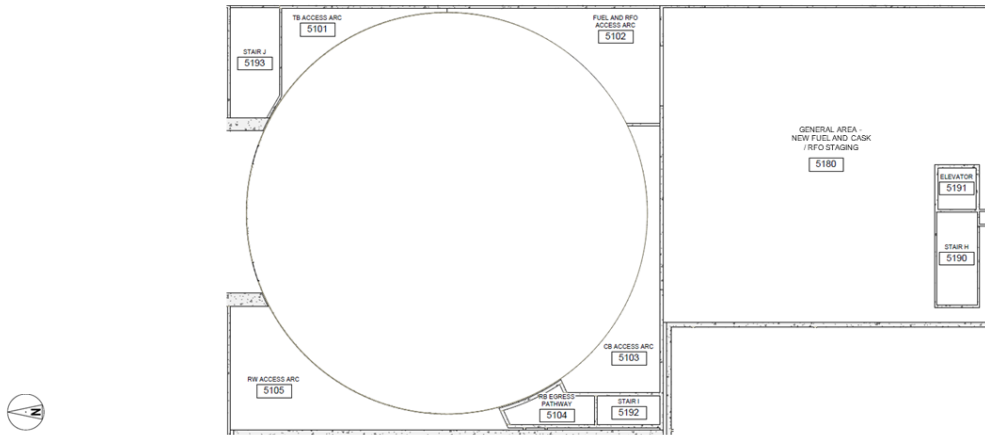

Figure 12-15: Service Building Level 0.0 m Radiation Zones

NEDO-34175 Revision A

Radiation Zones Level 6.1m/6.7m

ROOM	DESCRIPTION	FULL POWER	SHUTDOWN
5101	TURBINE BUILDING ACCESS ARC	B	B
5102	FUEL AND REFUELING OUTAGE ACCESS ARC	B	B
5103	CONTROL BUILDING ACCESS ARC	B	B
5105	RADWASTE BUILDING ACCESS ARC	B	B
5190	STAIR H	A	A
5191	ELEVATOR	A	A
5192	STAIR I	B	A
5193	STAIR J	B	A
5200	HALLWAY 6.7	A	A
5201	TB-SB HALLWAY	B	A

Radiation Zones Level 6.1m/6.7m

ROOM	DESCRIPTION	FULL POWER	SHUTDOWN
5203	STAIR I VESTIBULE 6.1	B	B
5205	YARD OBSERVATION E	Unoccupied/Controlled Access	
5206	YARD OBSERVATION F	Unoccupied/Controlled Access	
5207	YARD OBSERVATION G	Unoccupied/Controlled Access	
5280	HEALTH PHYSICS AREAS	A	A
5281	COLD SHOP / MAINTAINENCE	A	A
5282	SPECIAL USE / FLEX	A	A
5283	WOMENS REST ROOM	A	A
5284	MENS REST ROOM	A	A

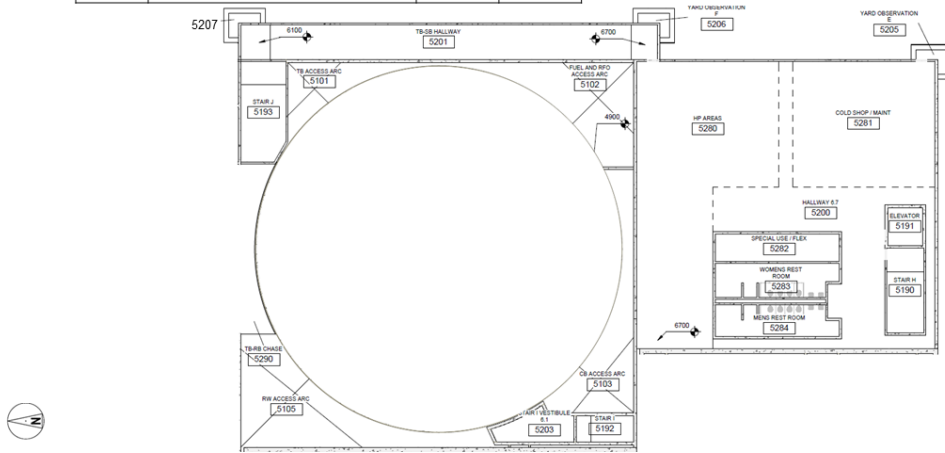

Figure 12-16: Service Building Level 6.1/6.7 m Radiation Zones

NEDO-34175 Revision A

Radiation Zones Level 13.0m

ROOM	DESCRIPTION	FULL POWER	SHUTDOWN
5101	TURBINE BUILDING ACCESS ARC	B	B
5102	FUEL AND REFUELING OUTAGE ACCESS ARC	B	B
5103	CONTROL BUILDING ACCESS ARC	B	B
5105	RADWASTE BUILDING ACCESS ARC	B	B
5190	STAIR H	A	A
5191	ELEVATOR	A	A
5192	STAIR I	B	A

Radiation Zones Level 13.0m

ROOM	DESCRIPTION	FULL POWER	SHUTDOWN
5193	STAIR J	B	A
5300	HALLWAYS	A	A
5302	STAIR J VESTIBULE 13.0	B	B
5380	OFFICES	A	A
5381	OUTAGE CENTER	A	A
5382	OTHER ROOMS	A	A

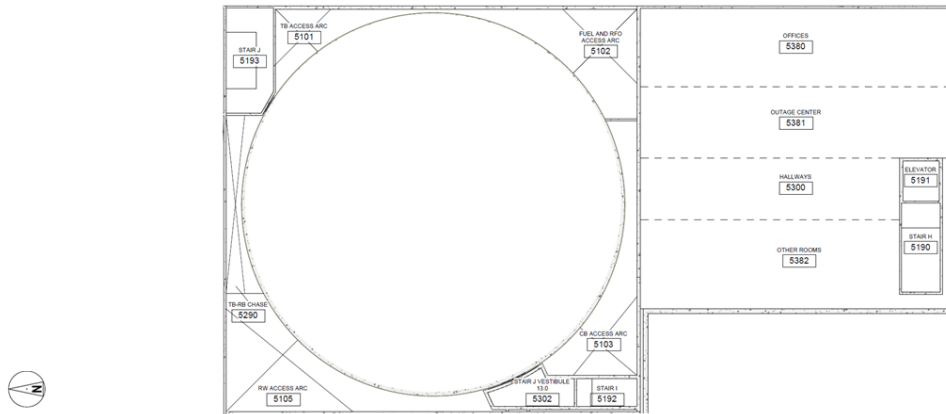

Figure 12-17: Service Building Level 13.0 m Radiation Zones

NEDO-34175 Revision A

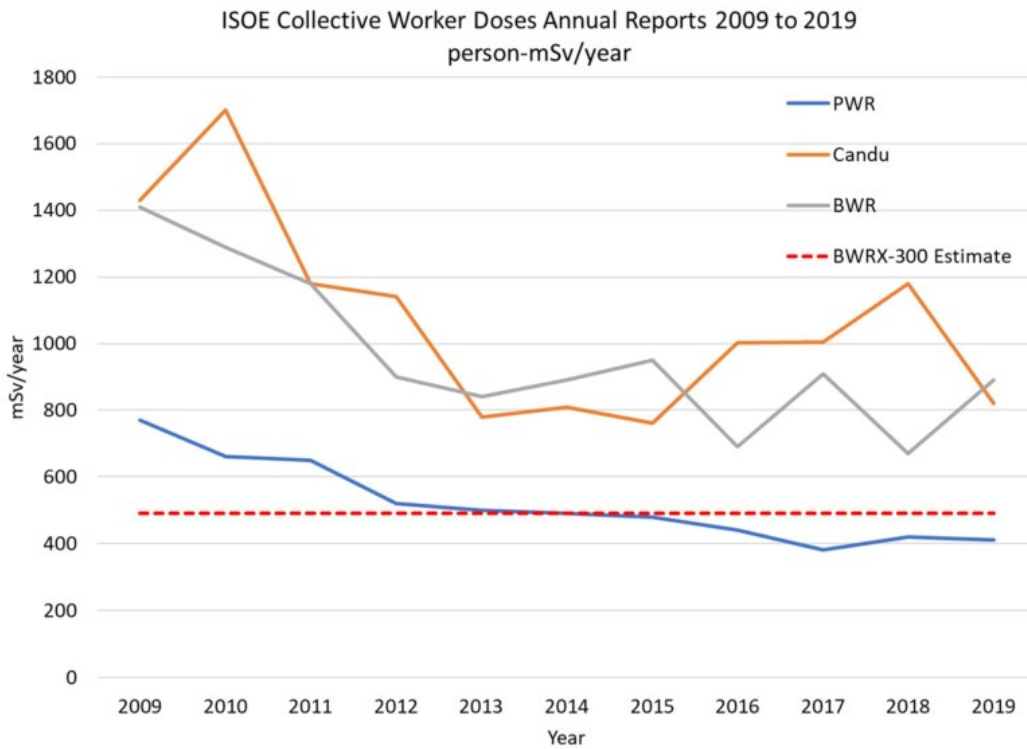

Figure 12-18: Comparison of BWRX-300 Collective Dose Estimate (491 mSv/year) with ISOE Industry Operating Data

NEDO-34175 Revision A

12.6 References

- 12-1 SSG-61, "Format and Content of the Safety Analysis Report for Nuclear Power Plants," Specific Safety Guide, IAEA, 2021.
- 12-2 NEDC-34165P, "BWRX-300 UK Generic Design Assessment Ch. 3: Safety Objectives and Design Rules for Structures, Systems and Components (SSCs)," Rev A, GE-Hitachi Nuclear Energy, Americas, LLC.
- 12-3 NEDC-34195P, "BWRX-300 UK Generic Design Assessment Ch. 23: Reactor Chemistry," Rev A, GE-Hitachi Nuclear Energy, Americas, LLC.
- 12-4 NEDC-34199P, "BWRX-300 UK Generic Design Assessment Ch. 27: ALARP Evaluation," Rev A, GE-Hitachi Nuclear Energy, Americas, LLC.
- 12-5 Code of Federal Regulations, "Title 10," Parts 1 to 50, U.S. Government Publishing Office, 1 January 2023.
- 12-6 "Safety Assessment Principles for Nuclear Facilities," Rev 1, Office for Nuclear Regulation, 2014 Editions, January 2020.
- 12-7 007N8600, "BWRX-300 Radioactive Sources in the Control Rod Drive System," Rev 0, GE-Hitachi Nuclear Energy, Americas, LLC, January 2024.
- 12-8 007N9365, "BWRX-300 Reactor Water Cleanup System and Shutdown Cooling System Design Basis Source Terms," Rev 0, GE-Hitachi Nuclear Energy, Americas, LLC, January 2024.
- 12-9 007N9880, "BWRX-300 Fuel Pool Gamma Source," Rev 0, GE-Hitachi Nuclear Energy, Americas, LLC, January 2024.
- 12-10 007N9016, "BWRX-300 Standard Plant Fuel Pool Cooling and Cleanup System and Isolation Condenser Cooling and Cleanup System Contained Source Activities," Rev 0, GE-Hitachi Nuclear Energy, Americas, LLC, January 2024.
- 12-11 008N0037, "Steam Jet Air Ejectors and Offgas System Inventory Calculation for the BWRX-300 Standard Plant," Rev 0, GE-Hitachi Nuclear Energy, Americas, LLC, January 2024.
- 12-12 007N9302, "BWRX-300 Standard Plant Liquid Waste Management System Contained Source Activity," Rev 0, GE-Hitachi Nuclear Energy, Americas, LLC, January 2024.
- 12-13 008N0133, "BWRX-300 Solid Waste Management System Contained Source Activity," Rev 0, GE-Hitachi Nuclear Energy, Americas, LLC, January 2024.
- 12-14 007N9701, "BWRX-300 Standard Plant Reactor Building Airborne Radioactivity for Normal Operation," Rev 0, GE-Hitachi Nuclear Energy, Americas, LLC, January 2024.
- 12-15 007N9666, "BWRX-300 Standard Plant Radwaste Building Airborne Radioactivity for Normal Operation," Rev 0, GE-Hitachi Nuclear Energy, Americas, LLC, January 2024.
- 12-16 007N7860, "BWRX-300 Standard Plant Turbine Building Airborne Radioactivity Concentrations During Normal Operations," Rev 0, GE-Hitachi Nuclear Energy, Americas, LLC, August 2023.
- 12-17 006N5081, "BWRX-300 As Low as Reasonably Achievable Design Criteria for Standard Design," Rev 0, GE-Hitachi Nuclear Energy, Americas, LLC, August 2024.
- 12-18 NS-G-1.13, "Radiation Protection Aspects of Design for Nuclear Power Plants," Safety Standards Series, IAEA, November 2005
- 12-19 007N3183, "Annual Occupational Collective Radiation Dose for BWRX-300," Rev 1, GE-Hitachi Nuclear Energy, Americas, LLC, January 2024.

NEDO-34175 Revision A

- 12-20 “Occupational Exposures at Nuclear Power Plants,” Annual Report of the Information System on Occupational Exposure (ISOE) Programme, Nuclear Energy Agency, 2009 through 2019 (Publicly Available Document Series).
- 12-21 NEDC-34140P, “BWRX-300 UK GDA Safety Case Development Strategy,” Rev 0, GE-Hitachi Nuclear Energy, Americas, LLC.
- 12-22 NEDC-34178P, “BWRX-300 UK Generic Design Assessment Ch. 15: Safety Analysis (Including Fault Studies, PSA and Hazard Assessment),” Rev A, GE-Hitachi Nuclear Energy, Americas, LLC.
- 12-23 “Work with Ionising Radiation – Ionising Radiation Regulations 2017,” Approved Code of Practice and Guidance L121, Health and Safety Executive, Second Edition, 2018.
- 12-24 “Expert Guidance on Risk Management, Health and Safety Executive,” <https://www.hse.gov.uk/enforce/expert/index.htm>, (last accessed August 2024).

NEDO-34175 Revision A

APPENDIX A CLAIMS, ARGUMENTS AND EVIDENCE

A.1 Claims, Argument, Evidence (CAE)

The Office for Nuclear Regulation (ONR) Safety Assessment Principles (SAPs) 2014 (Reference 12-6) identify ONR's expectation that a safety case should clearly set out the trail from safety claims, through arguments to evidence. The CAE approach can be explained as follows:

1. Claims (assertions) are statements that indicate why a facility is safe,
2. Arguments (reasoning) explain the approaches to satisfying the claims,
3. Evidence (facts) supports and forms the basis (justification) of the arguments.

The Generic Design Assessment (GDA) CAE structure is defined within the Safety Case Development Strategy (SCDS), NEDC-34140P, "BWRX-300 UK GDA Safety Case Development Strategy," (Reference 12-21) and is a logical breakdown of an overall claim that:

"The BWRX-300 is capable of being constructed, operated and decommissioned in accordance with the standards of environmental, safety, security and safeguard protection required in the UK".

This overall claim is broken down into Level 1 claims relating to environment, safety, security, and safeguards, which are then broken down again into Level 2 area related sub-claims and then finally into Level 3 (chapter level) sub-claims.

The Level 3 sub-claims that this chapter demonstrates compliance against are identified within the SCDS (Reference 12-21) and are as follows:

- 2.1.2. *The design of the system/structure has been substantiated to achieve the safety functions in all relevant operating modes.*
- 2.1.3 *The system/structure design has been undertaken in accordance with relevant design codes and standards (RGP) and design safety principles, and taking account of Operating Experience to support reducing risks to ALARP.*

In order to facilitate compliance, demonstration against the above Level 3 sub-claims, this PSR chapter has derived a suite of arguments that comprehensively explain how their applicable Level 3 sub-claims are met (see Table A-1 below).

It is not the intention to generate a comprehensive suite of evidence to support the derived arguments, as this is beyond the scope of GDA Step 2. However, where evidence sources are available, examples are provided.

NEDO-34175 Revision A

A.2 Risk Reduction As Low As Reasonably Practicable

It is important to note that nuclear safety risks cannot be demonstrated to have been reduced ALARP within the scope of a 2-Step GDA. It is considered that the most that can be realistically achieved is to provide a reasoned justification that the BWRX-300 Small Modular Reactor (SMR) design aspects will effectively contribute to the development of a future ALARP statement. In this respect, this chapter contributes to the overall future ALARP case by demonstrating that:

- The chapter-specific arguments derived may be supported by existing and future planned evidence sources covering the following topics:
 - RGP has demonstrably been followed,
 - OPEX has been taken into account within the design process,
 - All reasonably practicable options to reduce risk have been incorporated within the design.
- It supports its applicable level 3 sub-claims, defined within the SCDS (Reference 12-21)

Probabilistic safety aspects of the ALARP argument are addressed within PSR, NEDC-34178P, “BWRX-300 UK Generic Design Assessment Ch. 15: Safety Analysis (Including Fault Studies, PSA and Hazard Assessment),” (Reference 12-22).

NEDO-34175 Revision A

Table A-1: Radiation Protection Claims and Arguments

Level 3 Chapter Claim	Chapter 12 Argument	Sections and/or Reports that Evidence the Arguments
<p>2.1 The functions of systems and structures have been derived and substantiated taking into account RGP and OPEX, and processes are in place to maintain these through-life.</p>		
<p>2.1.2 The design of the system/structure has been substantiated to achieve the safety functions in all relevant operating modes.</p>	<p>Source terms for dose assessments have been shown to be sufficiently developed and conservative. Dose assessments for the key activities during operation and outages are used to demonstrate that the shielding design is appropriate to meet the requirements of radiation zones and to ensure the occupational doses are below legal limits.</p>	<p>12.2 Source of Radiation 12.4 Dose Constraints and Dose Assessment.</p>
<p>2.1.3 The system/structure design has been undertaken in accordance with relevant design codes and standards (RGP) and design safety principles, and taking account of Operating Experience to support reducing risks to ALARP.</p>	<p>The ALARP principles focussed on the risk of radiation exposure are consistently applied during the design of equipment and facility, integrating RGP and OPEX. Design criteria consistent with U.S. regulatory guidance have been established to meet ALARP objectives in line with international standards.</p>	<p>12.1.1 Approach to ALARP</p>

NEDO-34175 Revision A

APPENDIX B FORWARD ACTION PLAN

Table B-1: Radiation Protection Forward Action Plan Items

FAP No.	Finding	Forward Actions	Delivery Phase
PSR12-2	The total collective occupational (annual) dose has been estimated for the BWRX-300 standard design. However team sizes for key maintenance activities are not determined and thus comparisons with the UK ONR SAP Numerical Targets 1&2 cannot be presented in the PSR.	Determine and justify the numerical targets to be adopted for the UK implementation of the BWRX-300 and document them in the specification for the safety case manual for implementation of the BWRX-300 in the UK. Note: detailed methods development and performance of analysis, including team sizes, will be in a later licensing phase.	Within Step 2

NEDO-34175 Revision A

APPENDIX C UK SPECIFIC CONTEXT INFORMATION

C.1 Radiation Protection Principles in the UK

The regulation of radiation protection in the UK is governed by the Ionising Radiations Regulations 2017 (IRR17), “Work with Ionising Radiation – Ionising Radiation Regulations 2017,” (Reference 12-23) and also the principles and criteria presented in the Safety Assessment Principles (SAPs) for Nuclear Facilities (Reference 12-6).

UK Health and Safety Executive (HSE) developed a suite of guidance documents consisting of six parts, “Expert Guidance on Risk Management, Health and Safety Executive,” (Reference 12-24) as follows, explaining the concept “reasonably practicable” and providing guidance about what they should expect to see in duty holders demonstrations that the risk has been reduced ‘as low as reasonably practicable’ (ALARP).

1. Assessing compliance with the law in individual cases and the use of good practice
2. Policy and guidance on reducing risks as low as reasonably practicable in design
3. Principles and guidelines to assist HSE in its judgments that duty holders have reduced risk as low as reasonably practicable
4. HSE principles for Cost Benefit Analysis (CBA) in support of ALARP decisions
5. CBA Checklist
6. ALARP “at a glance”

With respect to radiation protection, operators must demonstrate that radiation doses (all risks) to workers and members of the public from nuclear facilities are ALARP.

The primary scope of radiation protection to demonstrate that the exposure is ALARP consists of:

- Doses to workers during normal operation, which covers start-up conditions, steady-state and shutdown conditions as well as outages, including maintenance, and minor incidents. Furthermore, the conditions of transport and storage of radioactive and/or contaminated items including spent fuel are included.
- Doses to the public arising from direct and scattered radiation originating from the site during normal operation.

Generally, design considerations and methods that are deployed to maintain in plant radiation exposures ALARP, have two objectives:

- Minimising the necessity for and the amount of time spent in radiation areas for personnel.
- Minimising radiation levels in routinely occupied plant areas and in the vicinity of plant equipment expected to require personnel attention.

In addition to the requirement to demonstrate ALARP exposure, the SAPs assign levels and objectives for radiation doses to individuals and groups. The dose constraints are discussed in Section C.2. An important element of optimisation of protection is that the collective dose to individuals on and off site, as a result of operation of the nuclear facility, should be kept ALARP.

Six principles specific for radiation protection are stated in the SAPs (Reference 12-6). These are discussed below along with the key information in this report that is used to satisfy them.

Adequate protection against exposure to radiation and radioactive substances should be provided in those parts of the facility to which access is permitted during normal operation.

NEDO-34175 Revision A

As a result of the BWRX-300 standard design approach, the dose to workers received during normal operations is reduced to ALARP, which is achieved predominantly on the basis of engineered features. The use of radiation zones (Section 2.3.1.4 Radiation and Contamination Zoning) allows estimating the doses received by workers during activities anywhere on plant. Various monitoring systems have been developed including area monitoring and sampling systems and appropriate personal protection equipment will be used. As a result, adequate protection of workers against exposure to radiation and radioactive substances during normal operation is in place.

Adequate protection against exposure to radiation and radioactive contamination should be provided in those parts of the facility that will need to be accessed during faults or as part of accident management (...).

The analysis of faults is out of the scope of this PSR. The demonstration of adequate radiation protection in accident scenarios will be subject to future licensing stages.

Where appropriate, designated areas should be further divided, with associated controls, to restrict exposure and prevent the spread of radioactive material.

The existing radiation zoning scheme for the BWRX-300 further subdivides the controlled area and establishes varying access conditions (Table 12-1). Detailed arrangement for access, occupancy and personal protective equipment will be made as part of establishing the zoning scheme for the UK BWRX-300 facility. See also Section C.3.

Effective means for protecting persons entering and working in contaminated areas should be provided.

Various measures are in place to minimise contamination and the spread of airborne activity (Section 2.3.1.3 Layout and Access). In conjunction with a range of monitoring systems as well as personal protective equipment being used as appropriate, effective means for protecting persons entering and working in contaminated areas are provided.

Suitable and sufficient arrangements for decontaminating people, the facility, its plant and equipment should be provided.

Means to facilitate decontamination of potentially contaminated areas are provided where practicable, and surface finishes are selected to facilitate easy decontamination, see Section 12.3.1.

Where shielding has been identified as a means of restricting dose, it should be effective under all normal operation and fault conditions where it provides this safety function.

As outlined in Section 12.3.2, the primary objective of radiation shielding is protecting operating personnel and the general public from radiation emanating from the reactor, the power conversion systems, the radwaste process systems, and the auxiliary systems, while maintaining appropriate access for operation and maintenance. Source terms in various pieces of plant equipment are discussed in Section 12.2. Shutdown conditions, such as fuel transfer operation, as well as accident conditions are considered in designing shielding for the plant.

NEDO-34175 Revision A

C.2 Radiation Safety Criteria in the UK

The HSE SAPs provide the Basic Safety Levels (BSLs) and the Basic Safety Objectives (BSOs). These encompass the legal limits defined in the Ionising Radiations Regulations. The employer (and so the designers and operators) must ensure doses are ALARP beyond the BSO. The specific UK individual dose constraints are presented in Table C-1.

Annual collective dose estimates have been derived for the BWRX-300 (Section 12.4). To demonstrate that individual annual worker doses comply with the UK regulatory targets, the number of workers for each activity considered is required. These staffing levels are typically determined by the operator and will be estimated in a later licensing stage. The determination and justification of the numerical targets to be adopted for the UK implementation of the BWRX-300 is part of the Forward Action Plan, see APPENDIX B. The comparison of the conservative overall collective dose to other BWRs (Figure 12-18) provides confidence that annual worker dose limits will be met.

NEDO-34175 Revision A

C.3 Consideration for Zoning

A zoning scheme has been established as part of the BWRX-300 standard design, see Table 12-1. This scheme is based on the total dose rate from both contained sources and potential airborne activity. Each zone is assigned an upper dose rate limit as well as a maximum stay time for a person. The zoning scheme is an important basis for the shielding design of the plant.

The ultimate objective of radiological zoning is to minimise dose exposure to workers by controlling access to areas of the plant with elevated dose rates and potential radioactive contamination. The future licensee is expected to implement their own operational radiological zoning scheme. Such scheme could be based on the existing BWRX-300 scheme or alternatively introduce a very different set of zone definitions.

Several factors will have to be considered by the licensee with regards to the establishment of a zoning scheme and the designation of areas based on this scheme.

The designation of classified areas is a requirement of UK law and is the responsibility of the future licensee. IRR17 defines a 'Controlled Area' as:

"Every employer must designate as a controlled area any area under its control which has been identified by an assessment made by that employer (whether pursuant to regulation 8 or otherwise) as an area in which -

- a. it is necessary for any person who enters or works in the area to follow special procedures designed to restrict significant exposure to ionising radiation in that area or prevent or limit the probability and magnitude of radiation accidents or their effects; or*
- b. any person working in the area is likely to receive an effective dose greater than 6.0 mSv a year or an equivalent dose greater than 15.0 mSv a year for the lens of the eye or greater than 150.0 mSv a year for the skin or the extremities."*

In addition, IRR17 states:

"An employer must not intentionally create in any area conditions which would require that area to be designated as a controlled area unless that area is for the time being under the control of that employer."

Similarly, IRR17 defines a 'Supervised Area' as:

"An employer must designate as a supervised area any area under its control, not being an area designated as a controlled area -

- a. where it is necessary to keep the conditions of the area under review to determine whether the area should be designated as a controlled area; or*
- b. in which any person is likely to receive an effective dose greater than 1.0 mSv a year or an equivalent dose greater than 5.0 mSv a year for the lens of the eye or greater than 50.0 mSv a year for the skin or the extremities."*

The following Approved Code of Practise (ACOP) has been established (Reference 12-23):

"Special procedures should always be necessary to restrict the possibility of significant exposure. Employers should designate controlled areas in cases where:

- a. the external dose rate in the area exceeds 7.5 μ Sv per hour when averaged over the working day;*
- b. the hands of an employee can enter an area and the 8-hour time average dose rate in that area exceeds 75 μ Sv per hour;*

NEDO-34175 Revision A

- c. *there is a risk of spreading significant radioactive contamination outside the working area;*
- d. *it is necessary to prevent, or closely supervise, access to the area by employees who are unconnected with the work with ionising radiation while that work is under way;*
- e. *employees are liable to work in the area for a period sufficient to receive an effective dose in excess of 6 mSv a year.”*

It is also recommended (Reference 12-23):

“In deciding whether or not a controlled area is needed, employers should consider:

- a. *which people are likely to need access to the area;*
- b. *the level of supervision required;*
- c. *the nature of the radiation sources in use and the extent of the work in the area;*
- d. *the likely external dose rates to which anyone can be exposed;*
- e. *the likely periods of exposure to external radiation;*
- f. *the physical control methods already in place, such as permanent shielding and ventilated enclosures;*
- g. *the importance of following a procedure closely in order to avoid receiving significant exposure;*
- h. *the likelihood of contamination arising and being spread unless strict procedures are closely followed;*
- i. *the need to wear PPE in that area;*
- j. *maximum doses estimated for work in the area.”*

Based on UK ACOP, areas are usually designated as controlled areas in the UK if the dose rate exceeds 7.5 $\mu\text{Sv/h}$. The existing BWRX300 zoning scheme does not have a zone boundary at this dose rate. To align the zoning scheme with UK ACOP the definition of the zone A (Table 12-1) could be altered to extend up to 7.5 $\mu\text{Sv/h}$. Also, whilst not specifically recommended, nuclear facilities in the UK usually operate with fewer radiation zones than the scheme in Table 12-1. A transition from the existing BWRX300 scheme to a scheme with fewer zones could be achieved by mapping the zones such that the upper boundaries are not lowered. This would ensure that compliance with a dose rate limit in the original scheme implies compliance with the new dose rate limit. Table C-2 show the potential mapping to an example scheme with fewer zones. However, it is noted that the introduction of a new zoning scheme would require revisiting the shielding design which is based on the expected dose rates across the plant as per the area designation. Also, the designation of areas using a new scheme would require the assessment of various factors, such as building boundaries, interlocks and access procedures.

In the UK a separate zoning scheme for contamination levels is usually established by the licensee, which also distinguished supervised and controlled areas. Such a scheme currently does not exist as part of the BWRX-300 standard design. Consideration would need be given by the licensee to adopting such scheme and designate areas on that basis.

NEDO-34175 Revision A

Table C-1: Radiation Safety Criteria

Description	Annual Dose (mSv)	
	BSL*	BSO*
Employees working with ionising radiation	20 (LL**)	1
Other employees on site	2	0.1
Average to a group of employees working with ionising radiation	10	0.5
Any person off the site from sources of ionising radiation on the site	1 (LL**)	0.02

Notes:

*: BSL, BSO refer to HSE Safety Assessment Principles for Nuclear Facilities

** : LL – Legal Limit defined in Ionising Radiation Regulations, 2017

NEDO-34175 Revision A

Table C-2: Mapping of BWRX-300 Zoning Scheme to an Example New Scheme

BWRX-300 Scheme		Example New Scheme	
BWRX-300 Zone	Upper Limit ($\mu\text{Sv/h}$)	New Zone	Upper Limit ($\mu\text{Sv/h}$)
A	6	Supervised (R1)	7.5
B	10	Controlled (R2)	25
C	50	Controlled (R3)	100
D	250	Controlled (R4)	500
E	1000	Controlled (R5)	>500
F	10000	Controlled (R5)	>500
G	100000	Controlled (R5)	>500
H	1000000	Controlled (R5)	>500
I	5000000	Controlled (R5)	>500
J	>5000000	Controlled (R5)	>500