



HITACHI

GE Hitachi Nuclear Energy

NEDO-34174

Revision A

January 2025

*US Protective Marking: Non-Proprietary Information
UK Protective Marking: Not Protectively Marked*

BWRX-300 UK Generic Design Assessment (GDA) Chapter 11 – Management of Radioactive Waste

*Copyright 2025 GE Hitachi Nuclear Energy Americas, LLC
All Rights Reserved*

US Protective Marking: Non-Proprietary Information
UK Protective Marking: Not Protectively Marked

NEDO-34174 Revision A

INFORMATION NOTICE

This document does not contain proprietary information and carries the notations “US Protective Marking: Non-Proprietary Information” and “UK Protective Marking: Not Protectively Marked.”

IMPORTANT NOTICE REGARDING CONTENTS OF THIS REPORT

Please Read Carefully

The design, engineering, and other information contained in this document is furnished for the purpose of obtaining the applicable Nuclear Regulatory Authority review and determination of acceptability for use for the BWRX-300 design and licensing basis information contained herein. The only undertakings of GEH with respect to information in this document are contained in the contracts between GEH and its customers or participating utilities, and nothing contained in this document shall be construed as changing those contracts. The use of this information by anyone for any purpose other than that for which it is intended is not authorized; and with respect to any unauthorized use, no representation or warranty is provided, nor any assumption of liability is to be inferred as to the completeness, accuracy, or usefulness of the information contained in this document. Furnishing this document does not convey any license, express or implied, to use any patented invention or any proprietary information of GEH, its customers or other third parties disclosed herein or any right to publish the document without prior written permission of GEH, its customers or other third parties.

UK SENSITIVE NUCLEAR INFORMATION AND US EXPORT CONTROL INFORMATION

This document does not contain any UK Sensitive Nuclear Information (SNI) subject to protection from public disclosure as described in the Nuclear Industries Security Regulations (NISR) 2003, does not contain UK Export Controlled Information (ECI), and does not contain US Export Controlled Information (ECI) subject to the export control laws and regulations of the United States, including 10 CFR Part 810.

NEDO-34174 Revision A

EXECUTIVE SUMMARY

This chapter of the Preliminary Safety Report (PSR) presents the arrangements for management of the radioactive wastes (excluding Spent Nuclear Fuel) arising from commissioning, operation, and subsequent decommissioning of the BWRX-300 Small Modular Reactor in compliance with United Kingdom (UK) requirements.

It supports the overall claim that “The BWRX-300 is capable of being constructed, operated and decommissioned in accordance with the standards of environmental, safety, security and safeguard protection required in the UK”, and provides information to support the Level 1 claim that “The safety risks to workers and the public during the construction, commissioning, operation and decommissioning of the BWRX-300 have been reduced As Low As Reasonably Practicable (ALARP).”

The BWRX-300 design has been developed such as to reduce risks ALARP. It focuses on:

- Preventing/eliminating the generation of radioactive waste
- Where the generation of radioactive waste cannot be avoided then minimising the generation of that waste (activity and volume)
- Disposal or storage (pending future disposal) of any solid radioactive waste generated so that it is concentrated/contained
- Abating any permitted liquid and gaseous discharge before release to the environment

The designs of the majority of the radioactive waste management systems are at a conceptual level which aligns with regulatory guidance for Generic Design Assessment (GDA) and are based on proven technology. Although at concept design stage, the design is sufficiently developed to enable a high level assessment of the risks associated with radioactive waste operations. The chapter demonstrates that the risks associated with the design and operation of the radioactive waste management systems for the BWRX-300 are capable of being reduced ALARP as the design progresses into detailed design.

Claims and arguments relevant to GDA step 2 objectives and scope are summarised in Appendix A, along with an ALARP position. Appendix B provides a Forward Action Plan, which includes future work commitments and recommendations for future work where ‘gaps’ to GDA expectations have been identified.

NEDO-34174 Revision A

ACRONYMS AND ABBREVIATIONS

Acronym	Explanation
AHUs	Air Handling Units
ALARP	As Low As Reasonably Practicable
AOV	Air Operated Valve
ARM	Area Radiation Monitoring Subsystem
BAT	Best Available Techniques
BWR	Boiling Water Reactor
CAE	Claims, Argument and Evidence
CB	Control Building
CFD	Condensate Filters and Demineralizers System
CFS	Condensate and Feedwater Heating System
CIS	Containment Inerting System
CMon	Containment Monitoring Subsystem
CP	Corrosion Products
CRD	Control Rod Drive
CST	Condensate Storage Tank
CUW	Reactor Water Cleanup System
CWS	Circulating Water System
DCIS	Digital Control and Information Systems
EFS	Equipment and Floor Drain System
EFU	Emergency Filter Unit
FP	Fission Products
FPC	Fuel Pool Cooling and Cleanup System
FWP	Final Waste Package
GAC	Granular Activated Carbon
GDA	Generic Design Assessment
GDF	Geological Disposal Facility
GEH	GE Hitachi Nuclear Energy
HEPA	High Efficiency Particulate Air
HIC	High Integrity Containers
HLW	High Level Waste
HVAC	Heating, Ventilation and Cooling System
HWC	Hydrogen Water Chemistry
ICC	Isolation Condenser Pool Cooling & Cleanup System
IICC	Irradiated In-Core Components
ILW	Intermediate Level Waste

NEDO-34174 Revision A

Acronym	Explanation
IWS	Integrated Waste Strategy
LAW	Low Activity Waste
LfE	Learning from Experience
LLW	Low Level Waste
LWMS	Liquid Waste Management System
MCA	Main Condenser and Auxiliaries
MCR	Main Control Room
NPP	Nuclear Power Plant
OGS	Offgas System
ONR	Office for Nuclear Regulation
OPEX	Operating Experience
PCF	Pre-Conditioning Filter
PCW	Plant Cooling Water System
PER	Preliminary Environmental Report
PPS	Plant Pneumatics System
PREMS	Process Radiation and Environmental Monitoring System
PRM	Process Radiation Monitoring
PS	Process Sampling Subsystem
PSA	Plant Services Area
PSR	Preliminary Safety Report
RB	Reactor Building
RGP	Relevant Good Practice
RO	Reverse Osmosis
RPV	Reactor Pressure Vessel
RWB	Radwaste Building
RWST	Refuelling Water Storage Tank
SC	Safety Class
SC1	Safety Class 1
SC2	Safety Class 2
SC3	Safety Class 3
SCN	Non-Safety Class
SCDS	Safety Case Development Strategy
SCR	Secondary Control Room
SDC	Shutdown Cooling System
SDD	System Design Description
SF	Spent Fuel

NEDO-34174 Revision A

Acronym	Explanation
SJAE	Steam Jet Air Ejector
SMR	Small Modular Reactor
SSCs	Structures, Systems, and Components
SWMS	Solid Waste Management System
TASS	Turbine Auxiliary Steam Supply
TB	Turbine Building
TEPCO	Tokyo Electric Power Company
U.S.	United States
UK	United Kingdom
VLLW	Very Low Level Waste
WGC	Water, Gas, and Chemical Pads
WSILW	Wet Solid Intermediate Level Waste

NEDO-34174 Revision A

DEFINITIONS

Term	Definition
Overboarding	How the system maintains the overall water balance and/or level control

NEDO-34174 Revision A

TABLE OF CONTENTS

EXECUTIVE SUMMARY	iii
ACRONYMS AND ABBREVIATIONS	iv
DEFINITIONS	vii
11. MANAGEMENT OF RADIOACTIVE WASTE.....	1
11.1 Sources of Waste.....	3
11.2 Systems for Management of Liquid Radioactive Waste.....	5
11.3 Systems for Management of Solid Radioactive Waste	9
11.4 Systems for Management of Gaseous Radioactive Waste	14
11.5 Process and Effluent Radiological Monitoring and Sampling	17
11.6 References.....	28
APPENDIX A CLAIMS, ARGUMENTS AND EVIDENCE.....	30
A.1 Risk Reduction As Low As Reasonably Practicable	31
APPENDIX B FORWARD ACTION PLANS.....	35
APPENDIX C UK SPECIFIC CONTEXT INFORMATION	36

NEDO-34174 Revision A

LIST OF TABLES

Table 11-1: LWMS Interfaces.....	20
Table 11-2: SWMS Interfaces	21
Table 11-3: OGS Interfaces	22
Table 11-4: PRM Interfaces	23
Table A-1: Claims, Arguments and Evidence	32

LIST OF FIGURES

Figure 11-1: LWMS Waste Collection and Filtering Subsystem Simplified Diagram	24
Figure 11-2: Solid Waste Management System Simplified Diagram.....	25
Figure 11-3: Simplified Diagram of the OGS System.....	26
Figure 11-4: Process Radiation Monitoring Subsystem Simplified Diagram	27

NEDO-34174 Revision A

REVISION SUMMARY

Revision #	Section Modified	Revision Summary
A	All	Initial Issuance

NEDO-34174 Revision A

11. MANAGEMENT OF RADIOACTIVE WASTE

This chapter describes the BWRX-300 approach for the management of radioactive wastes and the design of the systems to implement this approach. It provides a description of the nature, volume and characteristics of the radioactive waste produced during the lifecycle of the plant during normal operations, maintenance, and decommissioning. The Structures, Systems, and Components (SSCs) used for managing and processing radioactive waste in normal operations and fault conditions are also described. The BWRX-300 is designed such that it can be operated with zero aqueous effluent discharges during normal operations.

The radioactive wastes that are generated through the lifecycle of the BWRX-300 are described, as well the route of each waste stream up to the boundary of the power block, including identification and description of the waste management engineering systems.

The proposed approach to radioactive waste management and future disposal is limited to a high-level discussion, such that sufficient information is provided to give confidence that suitable radioactive waste recycling, storage, packaging and disposal processes and techniques can be applied to safely manage the radioactive waste.

The following chapters of the BWRX-300 Preliminary Safety Report (PSR) are key interfaces with this topic:

- NEDC-34165P, “BWRX-300 UK GDA Preliminary Safety Report, Ch. 3: Safety Objectives and Design Rules for SSCs,” (Reference 11-1) – provides the safety and design principles integral to the design of the radioactive waste management systems and components.
- NEDC-34175P, “BWRX-300 UK GDA Preliminary Safety Report, Ch. 12: Radiation Protection,” (Reference 11-2) – highlights the radioactive waste management facility and equipment design features for radiation protection.
- NEDC-34193P, “BWRX-300 UK GDA Preliminary Safety Report, Ch. 21: Decommissioning and End of Life Aspects,” (Reference 11-3) – describes a provisional approach to decommissioning including the handling, processing, and disposal of generated radioactive waste to minimise environmental impact.
- NEDC-34195P, “BWRX-300 UK GDA Preliminary Safety Report, Ch. 23: Reactor Chemistry,” (Reference 11-4) – defines the primary source term for the BWRX-300, which affects the nature of operational radioactive waste and discharges.
- NEDC-34198P, “BWRX-300 UK GDA Preliminary Safety Report, Ch. 26: Interim Storage of Spent Fuel,” (Reference 11-5) – describes the BWRX-300 approach of managing Spent Fuel (SF) and Irradiated In-Core Components (IICC).

Whilst these chapters are the key interfaces, it is noted that there are also interfaces with any chapters covering engineered systems that produce waste or effluent that is managed by the systems described in this chapter.

This document interfaces with the Preliminary Environmental Report (PER), particularly the following chapters:

- NEDC-34221P, “BWRX-300 UK GDA Preliminary Environmental Report, Ch. E4: Information about the Design,” (Reference 11-6).
- NEDC-34222P, “BWRX-300 UK GDA Preliminary Environmental Report, Ch. E5: Radioactive Waste Management Arrangements,” (Reference 11-7).
- NEDC-34223P, “BWRX-300 UK GDA Preliminary Environmental Report, Ch. E6: Demonstration of BAT Approach,” (Reference 11-8).

NEDO-34174 Revision A

- NEDC-34224P, “BWRX-300 UK GDA Preliminary Environmental Report, Ch. E7: Quantification of Radioactive Discharges,” (Reference 11-9).
- NEDC-34226P, “BWRX-300 UK GDA Preliminary Environmental Report, Ch. E9: Prospective Radiological Assessment,” (Reference 11-10).

Claims and arguments relevant to GDA step 2 objectives and scope are summarised in Appendix A, along with an ALARP position. Appendix B provides a Forward Action Plan, which includes future work commitments and recommendations for future work where ‘gaps’ to GDA expectations have been identified. Appendix C summarises key regulatory expectations in the UK and presents considerations with regards to addressing these.

NEDO-34174 Revision A

11.1 Sources of Waste

11.1.1 Sources of Radioactivity in Waste

Operation of the BWRX-300 will lead to the generation of radionuclides that will then transfer into the water/steam recirculating through the Reactor Pressure Vessel (RPV) and be transported through the reactor systems. These radionuclides can be grouped into three main categories:

- Corrosion Products (CPs) that subsequently become irradiated.
- Fission Products (FPs) (including noble gases).
- Irradiated Products (including IICC).

Corrosion Products

CP are formed as a result of corrosion that occurs during the normal wear and tear of reactor operations and may arise in soluble or particulate form. CP arise through:

- Corrosion of structural materials within the reactor; and
- Corrosion of metals in the steam circuit, that are carried by the process water and steam to the RPV.

In both cases, the CP can become irradiated when exposed to the neutron flux in the reactor core.

Fission Products

The presence of FP in the reactor water and steam is mainly caused by two mechanisms:

- Trace amounts of uranium that may be present on the external surfaces of the fuel assemblies, so called “tramp uranium”.
- Leakage of volatile FP through small pinhole defects in the cladding surrounding the fuel in the reactor core.

Irradiation Products

Neutron irradiation of the reactor water will also produce radioactive isotopes. Of particular interest for the radioactive waste stream are carbon-14, argon-41 and tritium. There will also be nitrogen-16 present in the Offgas System (OGS), however, nitrogen-16 has a short half-life (7.12 seconds) so most of it will have decayed away and therefore its concentration will be low.

Carbon-14 is mainly produced following neutron capture by oxygen-17 in the reactor water. Due to the oxidising conditions in the upper part of the reactor core, the carbon-14 is most likely to be present as carbon dioxide, which can be transferred to the reactor steam.

The reactor water contains a very small amount of residual entrained air, which itself contains trace amounts of naturally occurring stable argon-40. The argon-40 becomes activated by capturing a neutron as the reactor water passes through the reactor core and the resulting argon-41 is transferred to the reactor steam.

Tritium (hydrogen-3) is mainly produced by neutron activation of naturally occurring deuterium (hydrogen-2) in the reactor water. Tritium is assumed to partition equally between steam and plant process water.

11.1.2 Anticipated Radioactive Wastes

The design of the BWRX-300 provides arrangements for the management of the radioactive wastes arising from its commissioning, operation, and subsequent decommissioning. Information on the BWRX-300 design features that minimise the creation of radioactive waste

NEDO-34174 Revision A

can be found in NEDC-34222P, PER Ch. E5 (Reference 11-7) and NEDC-34223P, PER Ch. E6 (Reference 11-8).

The BWRX-300 design includes a number of 'on-line' cleanup systems that continuously clean plant water to maintain it within parameters set out in 006N6766, "BWRX-300 Water Quality – Technical Requirements Specification," (Reference 11-11). These cleanup systems remove, concentrate, and contain soluble and insoluble contaminants (both radioactive and non-radioactive) and generate secondary radioactive wastes in the form of filter backwash sludges and spent ion exchange resins. These 'wet solid' wastes are subsequently transferred to the Solid Waste Management System (SWMS) for storage and management.

In addition to these 'on-line' systems the BWRX-300 design also provides a comprehensive system of floor and equipment drains, together with a series of sump tanks, to collect radioactive aqueous effluents ejected from the plant during normal operations and route these to the Liquid Waste Management System (LWMS) for treatment. The LWMS system provides a series of abatement technologies capable of cleaning the effluents to meet the Water Quality Specification (Reference 11-11), thereby facilitating their recycling and reuse in the plant. In this manner the BWRX-300 is therefore capable of being operated on a zero aqueous radioactive effluent discharge basis. It is therefore important to note that whilst termed a 'waste management system' the LWMS system actually performs the function of aqueous effluent treatment to facilitate recycling, and thereby minimises the generation of waste in line with the principle of waste hierarchy application.

In addition, the design of U50 Equipment and Floor drains provides segregated sump tanks to ensure that non-aqueous materials such as lubricating oils are drained, captured, and transferred into nominal 205 litre drums to avoid cross-contamination with aqueous effluents.

A range of dry solid wastes will be generated through operational, maintenance and repair/refurbishment on an ad hoc basis associated with activities undertaken in the radioactive areas of the plant throughout the operating life of the BWRX-300, as described in 006N7733, "BWRX-300 Solid Waste Management System (SWMS) System Design Description," (Reference 11-12). A range of similar wastes are anticipated to be generated during the decommissioning phase, and these are considered separately in NEDC-34193P, PSR Ch. 21 (Reference 11-3).

Dry solid radioactive wastes will arise in the form of contaminated articles and substances, such as air filters, and miscellaneous wastes including cartridge filters, activated carbon cartridges, Reverse Osmosis (RO) membranes, rags, plastic bags and packaging, paper, disposable clothing, personal protective equipment, tools, laboratory wastes and equipment utilised in radioactive areas of the plant.

Gaseous radioactive waste is generated due to activation of the reactor coolant during normal reactor operation, tramp uranium that may adhere to the outside of the fuel cladding during fabrication, and leakage of fission gas through miniscule defects that can occur in the fuel cladding.

NEDO-34174 Revision A

11.2 Systems for Management of Liquid Radioactive Waste

11.2.1 System and Equipment Functions

The LWMS reclaims, treats, and stores treated water from waste streams for use by other plant systems. The LWMS cleans liquid effluent collected from plant areas via the Equipment and Floor Drain System (EFS). The BWRX-300 LWMS design incorporates the lessons learned from worldwide light water reactor programs and the Operating Experience (OPEX) of several GEH Boiling Water Reactors (BWRs), most notably the Economic Simplified Boiling Water Reactor and the Advanced Boiling Water Reactor.

Normal Operations

The LWMS, described in 006N7729, "BWRX-300 Liquid Waste Management System (LWMS) System Design Description," (Reference 11-13), is designed to perform the following safety functions during normal operations:

- Collect potential radioactive effluent from plant areas via the EFS for processing and filtering, returning condensate quality water to the Condensate Storage Tank (CST).
- Transfer, hold, and filter the reactor well pool volume of water when the reactor head bolts are required to be loosened or tightened during an outage.
- Provide water during outages for under vessel washdown (CST).

Fault Conditions

The LWMS is designed to perform the following safety functions during faulted conditions:

- Provide an alternate source of water for the Control Rod Drive (CRD) system if the Condensate and Feedwater Heating System (CFS) is not available.
- Receive overboarding flow from the Shutdown Cooling System (SDC) and the Reactor Water Cleanup System (CUW).
- Provide a means to replenish the fuel pool, for example following a Design Basis Accident.

11.2.2 Safety Design Basis

LWMS components and piping that support the fundamental safety function of confinement of radioactivity are classified as Safety Class (SC) 3. However, LWMS components and piping associated with maintaining the containment pressure boundary are classified as Safety Class 1 (SC1).

Safety Category 1 Functions

LWMS shall provide containment isolation valves for piping that penetrates the containment boundary and is connected to the containment atmosphere.

Safety Category 2 Functions

None.

Safety Category 3 Functions

The following functions meet the criteria for Safety Category 3 because their normal function supports the fundamental safety function of containing radioactive material.

The Waste Collection and Filtering Subsystem and the Waste Sampling Subsystem perform the following Safety Category 3 functions:

- Collect and transport potentially contaminated water received from other plant waste streams.

NEDO-34174 Revision A

- Provide a means to terminate waste rejection to the environment.

Safety Category N Functions

- Reclaim, treat and transport to storage treated water from waste streams for use by other plant systems.
- Provide a means to reject and monitor treated waste streams to ensure concentrations of contaminants released to the environment are maintained within permissible limits.

11.2.3 Description

The purpose of the BWRX-300 LWMS is to collect radioactive aqueous effluent generated as the result of normal operation throughout the plant. It primarily receives radioactive effluent from the EFS, but it can also receive overboarding flow from the SDC and the CUW. Once the LWMS receives the effluent, it separates the waste for collection, treatment, and sampling, while the filtered water is returned to the CST for plant reuse. It also filters, stores and refills the reactor cavity water volume during refuelling, using the Refuelling Water Storage Tank (RWST).

The LWMS consists of collection tanks, sample tanks, treatment skids, RWST, CST, associated pumps, piping, and instrumentation. A description of the system operation is provided in section 11.2.6, with a simplified diagram of the LWMS waste collection and filtering subsystem shown in Figure 11-1 (Reference 11-13).

The LWMS removes radioactive contaminants from the water before it returns to the CST. If it is not feasible to return the water to the CST due to the plant's overall water inventory, the water could also be discharged to the environment. However, as demonstrated by document 006N7673, "BWRX-300 Water Balance Model," (Reference 11-14), the system water storage capacities are designed to cope with the maximum effluent transfer volumes that occur during refueling outages and include adequate capacity to support the zero aqueous effluent discharge philosophy for the plant.

The collection tanks, filtration skids, sample tanks, and their associated pumps are located in the Radwaste Building (RWB). The RWST and the tank discharge pumps are located in the Turbine Building (TB). The reactor well pool filter and the drain pumps are located in the Reactor Building (RB). The CST and associated pumps and valves are located in the TB. CST distribution piping is located throughout the TB, the RWB and RB (Reference 11-13).

11.2.4 Materials

Material and equipment selection for the system components is based on a 60-year design life, with appropriate provisions for maintenance and replacement. Components which may require periodic replacement and/or maintenance prior to the end of plant life include, but are not limited to, filter media, demineraliser resin, reverse osmosis membranes, electrical and electronics, O-rings, bearings, gaskets and seals, lubricants, valve disks, seats, and packing. The CST, collection/sample tanks, RWST, and system piping and valves are designed with stainless steel material for corrosion resistance (Reference 11-13).

11.2.5 Interfaces with Other Equipment or Systems

Table 11-1 below provides a listing and brief description of the LWMS interfaces with other systems. Further information including the interface boundaries can be found in document 006N7729, the LWMS System Design Description (SDD) (Reference 11-13).

11.2.6 System and Equipment Operation

The LWMS normally operates on a batch basis. Liquid radioactive effluent is collected into the collection tanks located in the RWB via the EFS. The liquid from the collection tanks is piped to the filtration skid for batch processing. Within the filtration skid, there are multiple

NEDO-34174 Revision A

components (which may be subject to change as the design evolves) that provide diverse means to remove a wide range of soluble and insoluble contaminants (both radioactive and non-radioactive). These skid-mounted components can be configured in such a way as to cope with various effluent compositions, providing mitigation against potential upstream faults (such as foreign material ingress). This approach is consistent with that applied at the Tokyo Electric Power Company (TEPCO) Fukushima-Daiichi site.

The skid-mounted components used in the filtration skid for abatement are:

- Sludge Consolidation Filter – a disposable roughing filter used to remove bulk suspended solids. The consolidation filter can also be used to remove bulk oil and grease contaminants should these be determined to be present.
- Pre-Conditioning Filter (PCF) – an organic absorber/filter using granular activated carbon to adsorb organic material that has passed through the consolidation filter.
- Ozone System – destroys any remaining organic content down to parts per billion levels. The Ozone System can also be used to process chemical waste and detergent waste should these be determined to be present.
- Ion Exchanger – destroys any remaining ozone and softens the effluent prior to processing with the RO system. The Ion Exchange System consists of multiple vessels capable of utilising new ion exchange media or partially expended resin from the downstream Polishing Ion Exchange System. Ion exchange removes a significant amount of the ionic loading on the RO system making the RO system more efficient.
- RO System – removes ~95% of the dissolved contaminants (radioactive and non-radioactive) and all colloidal matter in the incoming radioactive effluent. The RO reject stream is recycled through the filtration skid.
- Polishing Ion Exchanger – the Polishing Ion Exchanger operates downstream of the RO system to polish the RO permeate prior to return to the CST.

If the collection tank contents require pretreatment because they exceed the filter skid influent limits, the contents can be routed to the SWMS for processing through the spent resin tank for pretreatment. Following pretreatment through the SWMS, the tank contents are routed to the collection tank (Reference 11-13).

11.2.7 Instrumentation and Control

The LWMS provides the instrumentation to control and monitor (indicate and alarm) system operation and is operated and monitored from the Main Control Room (MCR). Major system parameters such as tank levels, process flow rates, filters, and filtration skids effluent conductivity are indicated and alarmed as required to provide operational information and performance assessment. The Process Radiation and Environmental Monitoring System (PREMS) (discussed in Section 11.5) continuously monitors the discharge of radioactivity to the environs (Reference 11-13).

11.2.8 Monitoring, Inspection, Testing and Maintenance

This section provides, in part, the basis for preparation of detailed maintenance procedures. It defines the maintenance philosophy, outlines the procedures for scheduled (preventative) and unscheduled (corrective) maintenance, and in-service inspections and surveillance. It also identifies interfacing systems needed to support maintenance operations.

Routine testing of the LWMS is conducted in accordance with normal power plant requirements for demonstrating system and component functionality and integrity. Any required inspections and testing would be determined as part of the work planning / work release approval process.

NEDO-34174 Revision A

The equipment and components of the LWMS are designed for easy inspection and maintenance during plant operation. System and equipment manuals are supplied to provide instructions and procedures for installation, operation, and maintenance. The manuals also include identification of recommended tools and spare parts (Reference 11-13).

11.2.9 Radiological Aspects

NEDC-34223P, PER Ch. E6 (Reference 11-8) outlines how the design of the BWRX-300 allows for the anticipated annual effluent discharge from the LWMS for normal operating conditions to be zero. The BWRX-300's abatement systems are highly effective and enable both plant water and drainage effluents to be cleaned and purified to meet Reactor Water Quality Specification, facilitating their recycling, and enabling the plant to operate with zero aqueous effluent discharges under normal operating conditions.

Document NEDC-XXXX, "Analysis of Environmental Discharge Data for US Nuclear Power Plants" (Reference 11-15) shows that several U.S. BWR plants operate on a zero aqueous effluent discharge basis and have done so for many years. For some plants, occasional aqueous effluent discharges are identified. This supports the assertion that BWRs are capable of being operated with zero aqueous effluent discharges under normal operating conditions, but that it is appropriate to include an allowance for aqueous effluent discharge in environmental permits to cover abnormal events.

Accidental discharge and discharge above regulatory limits are prevented through detection by Process Radiation Monitoring (PRM), alarms for abnormal conditions and by administrative controls. The LWMS is designed to automatically stop liquid discharge from the sample tanks upon receiving a signal from the PRM. To prevent tank leakage from exiting the building, the collection and sample tanks are enclosed within a concrete wall barrier. In the event that a tank failure occurs, the concrete wall containment area will prevent LWMS water from exiting the RWB.

11.2.10 Performance and Safety Evaluation

The performance of the LWMS to minimise liquid effluent releases during normal operation has been described throughout this section.

NEDO-34174 Revision A

11.3 Systems for Management of Solid Radioactive Waste

The SWMS comprises both engineered systems (for wet solid wastes management) and management arrangements (for dry solid wastes).

11.3.1 System Equipment and Functions

The equipment and components of the SWMS are designed for easy inspection and maintenance during plant operation. System and equipment manuals are supplied to provide instructions and procedures for installation, operation and maintenance. The manuals also include identification of recommended tools and spare parts.

Normal Operations

The SWMS is designed to perform the following safety functions during normal operations:

- Safely controls, collects, handles, processes, packages, and temporarily stores solid waste generated by the plant prior to preparing the waste for on-site storage or shipping offsite.
- Processes the LWMS filtering skid spent resins and filter backwash, lab waste, oily sump waste, filter backwash sludges, RO concentrates, charcoal media, and bead resins generated by the FPC, Isolation Condenser Pool Cooling & Cleanup System (ICC), and CFD systems.
- Disposal of contaminated solids such as High Efficiency Particulate Air (HEPA) and cartridge filters, rags, plastic, paper, clothing, tools, and equipment in the SWMS.

Faulted Conditions

The SWMS does not perform any safety functions during faulted conditions.

11.3.2 Safety Design Basis

Safety Category 1 Functions

None.

Safety Category 2 Functions

None.

Safety Category 3 Functions

The following function meets the criteria for Safety Category 3 because the SWMS's normal function supports the fundamental safety function of containing radioactive material.

The SWMS performs the following Safety Category 3 functions:

- The SWMS safely controls, collects, handles, processes, packages, and temporarily stores solid radioactive waste generated by the plant prior to shipping the waste offsite.

Safety Category N Functions

- Portions of the SWMS that do not support the fundamental safety function of containing radioactive material are Safety Category N.

11.3.3 Description

Wet Solid Waste

The purpose of the SWMS is to control, collect, handle, process, package and temporarily store solid waste generated by the plant prior to transferring the waste into on-site storage or transporting the waste offsite. It processes the LWMS filtering skid spent resins and filter backwash, lab waste, oily sump waste, filter backwash sludges, RO concentrates, charcoal media and bead resins generated by the FPC, Isolation Condenser System, ICC and CFD.

NEDO-34174 Revision A

The SWMS is described in detail in document 006N7733, "BWRX-300 Solid Waste Management System (SWMS) System Design Description," (Reference 11-12). A simplified diagram of the SWMS is provided in Figure 11-2.

The SWMS is primarily located in the RWB with individual collection locations around the plant, and consists of the following functions:

- Spent Resin Processing
- Sludge Processing
- Solid Waste Storage

Spent Resin Storage

Spent resin slurry from the LWMS, ICC, CFD (from three demineraliser vessels) and FPC is sent to the spent resin tank for collection and decay. On exhaustion of resin adsorption and tank capacity, resin is transferred to the Solid Waste Storage Subsystem to be prepared for disposal. Based on currently available source term data found in document 008N0133, "BWRX-300 Solid Waste Management System - Contained Source Activity," (Reference 11-16), the spent resin has initially been classified as wet solid Intermediate Level Waste (ILW).

Any tank or line flushes from the CST are directed to the EFS for collection and subsequently recycled for treatment by the LWMS. The spent resin tank can also receive water from the LWMS collection tanks. If filtration skid influent requirements are not met, the spent resin can pretreat the water, undergoing multiple pretreatment cycles, if necessary. The pretreated water will then undergo normal management through the LWMS (Reference 11-13).

Sludge Storage

Two sludge tanks are used to settle out solids that accumulate in process water as part of normal filter and demineraliser operation (refluidisation and flushing of the resins). Backwash from the three CFD filters and three demineralisers, the LWMS, and FPC filters, plus sludge from the LWMS, enters the tanks. After solid settling, the liquid is decanted off to the EFS and subsequently recycled for treatment by the LWMS. The remaining wet sludge is recirculated within the tank to create a homogeneous slurry, which is then transferred to the Solid Waste Storage Subsystem to be prepared for disposal. Liquid from the CST is used to flush the tanks and associated pipework to remove trace solids, prior to the acceptance of additional backwash (Reference 11-13). Based on currently available source term data, the sludge has initially been classified as Wet Solid ILW (WSILW).

Solid Waste Management

Operation of the aqueous liquid cleanup systems is anticipated to result in the generation of wet solid wastes in the form of filter backwash sludges, spent bead resins, and Granular Activated Carbon (GAC). The wet solid wastes arising from these abatement systems are routed to the SWMS for onward management. It is assumed that spent GAC, sludge consolidation filters and RO modules will arise as Low Activity Waste (LAW).

The WSILW streams are assumed to be transferred to an on-site WSILW processing capability, where they will be packaged and conditioned to form passively safe, disposable Final Waste Packages (FWP). The wastes are assumed to be solidified in a cementitious matrix within 3 m³ unshielded stainless-steel drums. Note that the final choice of waste container and related immobilisation method will be subject to appropriate consideration during site-specific design development. Packaging will comply with NWS waste packaging specifications and will be substantiated through their disposability assessment and letter of compliance process.

NEDO-34174 Revision A

The resultant FWP's will be transferred to an appropriately designed on-site storage facility pending eventual disposal to a national Geological Disposal Facility (GDF). A final decision on WSILW management strategy will be made at a future site-specific stage and will need to take account of a wider range of factors reflecting the site-specific design, to include consideration of a solution for a multiple unit site, and related considerations of shared facilities etc. (Reference 11-7).

Dry Solid Waste

Dry solid wastes include contaminated solids such as HEPA and cartridge filters, rags, plastic, paper, clothing, tools, and equipment, all of which are disposed of in the SWMS. LAW comprises both Low Level Waste (LLW) and Very Low-Level Waste (VLLW). Normal operation of the BWRX-300 is anticipated to generate the following LAW streams:

- Ventilation filters.
- Aqueous effluent filter modules.
- Heterogeneous dry solid wastes.
- Non-aqueous wet solid and liquid wastes.

Further information on the different LAW streams can be found in NEDC-34222P, PER Ch. E5 (Reference 11-7). However, dry solid wastes consist of air filters, miscellaneous paper, rags, etc., from contaminated areas; containment clothing, tools, and equipment parts that cannot be effectively decontaminated; and solid laboratory waste. These wastes are collected in containers located in appropriate areas throughout the plant, as dictated by volume of wastes generated during operation and maintenance. The filled containers are sealed and moved to controlled-access enclosed areas for temporary storage. On-site storage space for packaged waste including the High Integrity Containers (HICs), shielded filter containers, drums, and other shipping containers is provided in the RWB.

Irradiated In-Core Components

IICCs have been considered as part of NEDC-34198P, PSR Ch. 26 (Reference 11-5). Due to the levels of activation anticipated it is assumed that these wastes will emit significant levels of radiogenic heat ($>2 \text{ kW/m}^3$) and will therefore be classified as High Level Waste (HLW) on production. In line with the management strategy adopted for the UK Advanced Boiling Water Reactor (UKABWR), it is assumed that these wastes will be packaged and stored to benefit from radioactive decay until they meet the Intermediate Level Waste (ILW) classification ($<2 \text{ kW/m}^3$). Interim storage is assumed to be in dry casks, as for SF. This approach is considered appropriate as the wastes will be routed through the fuel pool on removal from the reactor, and therefore align with the provisions made in the fuel pool for cask handling and packaging. Dry casks containing HLW are assumed to be co-stored with SF casks in the Dry Fuel Store. Once the waste has decayed to ILW levels it will be recovered and repackaged as ILW.

11.3.4 Materials

Material and equipment selection for system components is based on a planned 60-year design life, with appropriate provisions for maintenance and replacement. Piping and tanks are stainless steel for corrosion resistance. Components which may require periodic replacement and/or maintenance prior to the end of plant life include, but are not limited to, electrical and electronics, O-rings, bearings, gaskets and seals, lubricants, valve disks, seats and packing (Reference 11-12).

NEDO-34174 Revision A

11.3.5 Interfaces with Other Equipment or Systems

Table 11-2: below provides a listing and brief description of the SWMS interfaces with other systems. Further information including the interface boundaries can be found in document 006N7733, the SWMS SDD (Reference 11-12).

11.3.6 System and Equipment Operation

Spent bead resin slurry from the ICC, CFD, FPC, and LWMS is collected in a dedicated spent resin tank for decay. Once enough resin is accumulated, it is transferred to High Integrity Containers for dewatering and further management.

To minimise trace solids and reduce radiation dose, tanks, piping, pumps, and valves are flushed with CST water. Filter and demineraliser backwash from the FPC and CFD systems is directed to two sludge tanks, allowing solids to settle. Additionally, backwash water from high-flow fine filtration systems can be routed to the SWMS sludge tanks for processing and liquid removal. Once sufficient sludge is collected, it is transferred to HICs for dewatering and disposal.

The spent resin and sludge tanks are sized to handle the expected waste volume from upstream systems feeding into the SWMS. Liquids from the SWMS are drained to the EFS, which then transfers the liquid to the LWMS for processing

Solids from lab samples, LWMS skid waste, and oily waste from the EFS are collected in a drum and loaded in the drum evaporator. The drum evaporator removes excess moisture, through evaporation, and routes the moisture to the RWB ventilation system for elimination (Reference 11-12).

11.3.7 Instrumentation and Control

Level transmitters are provided on each tank for high-level indication and alarm to prevent overflow of the tanks and the HICs.

Other parameters indicated and alarmed in the MCR include pump pressures, discharge flows, remote valve positions, process mode, evaporator temperature and level.

The majority of operations, including system operating mode selection and transfer pump operation, can take place remotely through the MCR control panel. System interlocks prevent tank overflow and prevent simultaneous transfer of spent resin and sludge to the HICs. System logic includes a flushing cycle to clean the tanks and transfer lines of any residual particulates which are then transferred to the HICs for further dewatering. Flexibility in system operation exists to allow backflushing of filters into the empty sludge tank while the full sludge tank is being processed to the HICs. This flush consists of clean water addition from the CST. The addition of the flush water to the tanks assures complete mixing and forwarding of suspended solids minimising the solids depositing within the transfer piping. Manual initiation is required to transfer the spent resin and sludge to the HICs (Reference 11-12).

11.3.8 Monitoring, Inspection, Testing and Maintenance

This section provides, in part, the basis for preparation of detailed maintenance procedures. It defines the maintenance philosophy, outlines the procedures for scheduled (preventative) and unscheduled (corrective) maintenance, and in-service inspections and surveillance. It also identifies interfacing systems needed to support maintenance operations.

Routine testing of the SWMS is conducted in accordance with normal power plant requirements for demonstrating system and component functionality and integrity. Any required inspections and testing would be determined as part of the work planning / work release approval process (Reference 11-12).

NEDO-34174 Revision A

11.3.9 Radiological Aspects

Document NEDC-34226P, PER Ch. E9 (Reference 11-10) summarises the analysis performed to determine the annual average solid waste arisings from the SWMS during normal operations.

It should be noted that the current wet solid waste inventory has been classified as ILW based on source term data, outlined in document 008N0133, "BWRX-300 Solid Waste Management System - Contained Source Activity" (Reference 11-16). This source term has been derived to provide bounding and conservative values for the purposes of dose and shielding calculations. A related conservative assumption on classification of the wastes provides a bounding consideration for their management. Should subsequent refinement of the source term result in the wastes being classified as LLW this would simplify the requirements for their management.

The SWMS is designed to include shielding and controls sufficient to limit accessible general area radiation levels during normal processing. During filter media or waste container transfer operations, processes and systems used for remote operation limit average worker radiation dose rates.

11.3.10 Performance and Safety Evaluation

The SWMS is capable of performing its system functions during all modes of operation. The spent resin tank is designed to hold and process two condensate demineraliser resin transfer amounts, while the sludge tanks are designed to hold four condensate filter backwash water volumes.

The SWMS pressure boundary components support the fundamental safety function of confinement of radioactivity. Corrosion resistant materials compatible with the media are chosen for service. There is no liquid plant discharge from the SWMS. Failure of the system does not compromise any other safety-category system or component, nor does it prevent shutdown of the plant. No interface with the safety class electrical system exists (Reference 11-12).

NEDO-34174 Revision A

11.4 Systems for Management of Gaseous Radioactive Waste

11.4.1 System and Equipment Functions

The OGS is a Safety Class 3 (SC3) system due to its support of these Defense Line 2 Fundamental Safety Functions:

- Removal of heat from the reactor and fuel, and from the fuel store, including long-term heat removal.
- Confinement of radioactive material, shielding against radiation, control of planned radioactive releases, and limitation of accidental radioactive release.

Normal Operations

The OGS is designed to perform the following safety functions during normal operations:

- Recombination of hydrogen and oxygen into water to maintain plant water inventory and reduce hydrogen detonation risk.
- Controlled adsorptive holdup of the radioactive isotopes of krypton, xenon, and argon to achieve adequate decay, thereby reducing effluent radioactivity releases from the plant.

Faulted Conditions

The OGS does not perform any safety functions during faulted conditions.

11.4.2 Safety Design Basis

Safety Category 1 Functions

None.

Safety Category 2 Functions

None.

Safety Category 3 Functions

The following functions meet the basis for Safety Category 3 function because their normal function supports the fundamental safety function of containing radioactive material.

The OGS performs the following Safety Category 3 Functions:

- Provides a flow path to discharge offgas from the Main Condenser Steam Jet Air Ejector (SJAE) to the Heating, Ventilation, and Cooling System (HVAC).
- Recombines the hydrogen and oxygen in the offgas stream into water.
- Removes radioisotopes in the offgas effluent stream to ensure the dose to the public and plant personnel remains within permissible limits.

Safety Category N Functions

- The OGS condenses steam in the offgas stream and returns it to the main condenser.

11.4.3 Description

The objective of the OGS is to process and control the release of gaseous radioactive effluents to the site environs so as to maintain the exposure of persons in unrestricted areas to radioactive gaseous effluents as low as reasonably practicable.

The OGS provides for holdup and decay of radioactive gases in the offgas from the Main Condenser and Auxiliaries (MCA) system. The OGS minimises and controls the release of radioactive material into the atmosphere by delaying and filtering the offgas process steam

NEDO-34174 Revision A

containing the radioactive isotopes of krypton, xenon and argon sufficiently to achieve adequate decay before discharge from the plant.

Equipment for the OGS is located within the TB and the RWB. The primary effluent line of the OGS begins at the valve interface with the MCA system at the exit of the SJAEs within the TB. The OGS process ends with the transfer of the offgas effluent to the continuous exhaust air plenum of the HVAC System prior to final release, as described in 006N7899, "BWRX-300 Offgas System Design Description," (Reference 11-17). A simplified diagram of the OGS is provided in Figure 11-3.

11.4.4 Materials

Material and equipment selection for the OGS are based on a 60-year design life, with appropriate provisions for maintenance and replacement.

11.4.5 Interfaces with Other Equipment or Systems

Table 11-3 below provides a listing and brief description of the OGS interfaces with other systems. Further information, including the interface boundaries, can be found in document 006N7899, the OGS SDD (Reference 11-17).

11.4.6 System and Equipment Operation

The primary functions of the OGS are most applicable when the reactor is operating at high power. Production of radiolytic H₂ and O₂, and of radioactive noble gas isotopes, are minimal outside of Reactor Power Operation mode, and as such, the OGS is not required to be in operation during reactor startup, shutdown, and refuelling modes.

The Normal Operation Mode of the OGS begins at or just beyond 10% reactor power, where the main condenser vacuum is stable, much of the in-leakage has subsided, and higher levels of radiation (in the flow stream) are occurring, due to the rise in noble gas release from the fuel in the form of xenon and krypton. The flow of effluent is routed through all primary system components, including the offgas recombiner, cooler condenser, moisture separator, refrigeration dryer, charcoal vault and all charcoal canks, and the filter before being released (Reference 11-17).

11.4.7 Instrumentation and Control

A minimum offgas flowrate is maintained at all times while there is flow through the Offgas Recombiner to support normal function of the Catalytic Recombiner. Flow detectors continuously measure the minimum offgas flowrate and transmit a control signal upstream to the MCA to inject additional air into the effluent flow if this minimum is not met.

Controls for the OGS are available in the MCR to facilitate system operation. System and component operating status, including the state of any bypasses or manual overrides, are provided at the control console. Manual initiation and shutdown of the OGS is provided from the control room.

OGS parameter indications are provided in the MCR. The indications available include but are not limited to: Offgas Recombiner temperatures and flows, dryer outlet hydrogen and oxygen content, charcoal adsorber bed temperatures, OGS release effluent radiation and flow rates indications, oxygen levels, and OGS Discharge Radiation levels (Reference 11-17).

11.4.8 Monitoring, Inspection, Testing and Maintenance

The OGS has no requirements for in-service inspection. Routine testing of the OGS is conducted in accordance with normal power plant requirements for demonstrating system and component operability and integrity (Reference 11-17).

Equipment will not normally be accessible for maintenance during system operation. All equipment is available during the plant outage. The following are exceptions:

NEDO-34174 Revision A

- The redundant refrigeration dryer is accessible for maintenance while inactive.
- Charcoal vault air HVAC equipment is accessible for maintenance during plant operation.

11.4.9 Radiological Aspects

Document NEDC-34226P, PER Ch. E9 (Reference 11-10) summarises the analysis performed to determine the annual average gaseous effluent releases (including releases from the OGS) during normal operations.

The OGS minimises and controls the release of radioactive material into the atmosphere by delaying the release of the offgas process stream. This is sufficient to achieve adequate decay before the process offgas stream is discharged from the plant. The gaseous effluent treatment systems are designed to limit the dose to offsite persons from routine operations.

Charcoal Vault pressure is maintained slightly lower than atmospheric pressure relative to the general area pressure to mitigate the risk of noble gas leaks from the vault into the wider plant.

11.4.10 Performance and Safety Evaluation

The performance of the OGS to minimise gaseous effluent releases during normal operation has been described throughout this section.

NEDO-34174 Revision A

11.5 Process and Effluent Radiological Monitoring and Sampling

11.5.1 System and Equipment Functions

The PREMS performs safety category and non-safety category functions. The PREMS is not assigned an overall safety classification, rather classifications are made at the functional and/or component level. The PREMS supports Defense Lines 2, 3, and 4a functions, and includes SC1, 2, 3, and Non-SC components.

The PREMS, described in document 006N7938, "BWRX-300 Process and Radiation Environmental Monitoring System Design Description," (Reference 11-18) consists of the following four subsystems:

- PRM – the purpose of the PRM is to determine the content of radioactive material in various gaseous and liquid process and effluent streams. The PRM subsystem is the most relevant to this chapter because of its role in conducting process and effluent radiological monitoring.
- Area Radiation Monitoring Subsystem (ARM) – the purpose of the ARM is to continuously measure, indicate and record gamma radiation levels at strategic locations throughout the plant, except for the containment areas, and initiates alarms in the MCR, Secondary Control Room (SCR), and locally to warn personnel.
- Containment Monitoring Subsystem (CMon) – the purpose of the CMon is to provide instrumentation to monitor multiple parameters inside containment.
- Process Sampling Subsystem (PS) – The PS collects representative liquid and gaseous samples for analysis and provides the analytical information required for monitoring plant and equipment performance.

Normal Operations

The PRM is designed to perform the following safety functions during normal operations:

- Monitoring of various different gaseous and liquid streams as well as area radiation to provide personnel with sufficient warning to seek protection from exposure to radioactive material.
- Support of the following automatic functions:
 - LWMS discharge.
 - OGS discharge.
 - Lower RB HVAC intake.
 - Control Building (CB) HVAC intake.

Faulted Conditions

The faulted conditions functions initiated and monitored by the PRM instrumentation are the same as the normal operations functions.

11.5.2 Safety Design Basis

Safety Category 1 Functions

PRM shall provide containment isolation valves for piping that penetrates the containment boundary and is connected to the containment atmosphere.

Safety Category 2 Functions

None.

NEDO-34174 Revision A

Safety Category 3 Functions

- Monitors process and effluent streams for potentially radioactive noble gases, air particulates, and halogens.

The following automatic functions are supported by the PRM:

- LWMS Discharge: LWMS discharge to the Normal Heat Sink is secured if high radiation is detected at the offsite discharge line.
- RB HVAC Intake: HVAC SCR Emergency Filter Units (EFUs) and pressurisation fans are aligned to provide safe breathing air to the SCR if high radiation or toxic gas is detected at either of the lower RB supply Air Handling Units (AHUs).
- OGS Discharge: OGS discharge to the HVAC is secured if high radiation is detected downstream of the Charcoal Adsorber Beds.
- CB HVAC Intake: HVAC Control Room Envelope EFUs (and/or Toxic Gas Filtration Unit) are aligned to provide safe breathing air to the MCR if high radiation and toxic gas is detected at either of the CB supply AHUs.

Safety Category N Functions

None.

11.5.3 Description

PRM provides an assortment of monitoring equipment, with each device being tailored to the process/effluent stream according to fluid, location, and radiological hazard, as described in document 006N7938, the PREMS SDD (Reference 11-18). In general, the following types of monitoring equipment are used:

- Offline Radiation Monitors: Radiation monitoring assemblies that are installed external to and away from the process stream. A continuous sample is extracted from the process and/or effluent stream and conveyed to the assembly. An example is a combination skid that measures Particulate, Iodine and Noble Gas (PING) activities. These PING skids typically include three independent analyzers (3 channels), flow extraction/control equipment, grab sampling taps, a local control panel, and audible/visual alarms. Particulate filters, iodine filters (charcoal cartridges), and grab samples are periodically collected from the skids for isotopic analysis.
- Inline Radiation Monitors: Single radiation detection elements installed in the process stream. These detectors can be of the scintillation or ionization chamber style and are used to measure beta or gamma radiation.
- Adjacent-to-Line Radiation Monitors: Single radiation detection elements mounted externally to the process line. These detectors can be of the scintillation or ionization chamber style and used to measure gamma radiation.
- Area Radiation Monitors: General area radiation monitor. These detectors can be of the scintillation or ionization chamber style and are used to measure gamma radiation.

A simplified diagram of the PRM subsystem is provided in Figure 11-4.

11.5.4 Materials

The materials selected for use in the system have been chosen to fulfil environmental requirements. Components and cables used in radioactive areas are qualified for the anticipated or calculated radiation conditions.

NEDO-34174 Revision A

11.5.5 Interfaces with Other Equipment or Systems

Table 11-4 below provides a listing and brief description of the PRM interfaces with other systems. Further information including the interface boundaries can be found in document 006N7938, the PREMS SDD (Reference 11-18).

11.5.6 System and Equipment Operation

During normal operations, the monitoring equipment is continuously in operation, or performing periodic monitoring as required, unless removed from service for maintenance. Sampling equipment operates continuously, periodically, or in the grab sample mode. There may be cases where the system with which the PRM interfaces is out of service, in which case the instrumentation allocated to that system will be taken out of service.

There are no generic startup protocols. Specific startup operation descriptions may be applicable to the host systems that interface with PRM instrumentation.

The system performance requirements are generally the same for all operational modes (Reference 11-18).

11.5.7 Instrumentation and Control

PRM instrumentation design is organised primarily by the SC of the system functions that the instrumentation is supporting. PRM provides monitoring only; there are no mitigating system functions controlled by PRM. The PRM may provide the primary detection in some cases or be a secondary avenue in other cases to collect instrumentation readings or signals from other systems for transmission to the Digital Control and Information Systems (DCIS).

Each subsystem consists primarily of radiation detectors and transmitters. The sampling instrumentation primarily consists of grab samples which are analysed to identify and quantify the specific radionuclides in effluents. The results from the sample analysis are used to establish relationships between the gross gamma monitor readings and concentrations, or release rates of radionuclides in continuous effluent releases (Reference 11-18).

11.5.8 Monitoring, Inspection, Testing and Maintenance

Maintenance includes servicing and replacement of defective components and adjustments as required. Periodic testing or calibration checks will be performed as part of the maintenance plan. If any work is performed that would affect the calibration of the instrument, a recalibration is performed following the maintenance operation (Reference 11-18).

11.5.9 Radiological Aspects

The PRM provides an assortment of monitoring equipment, with each device being tailored to the process/effluent stream according to fluid, location, and radiological hazard. To the extent possible, the system components and subsystems are constructed to avoid contamination due to leakage, spills, errors in valve lineup or other operating conditions as a result of interfacing with radioactive systems.

11.5.10 Performance and Safety Evaluation

PRM provides monitoring only; there are no mitigating system functions controlled by PRM.

NEDO-34174 Revision A

Table 11-1: LWMS Interfaces

Interfacing System	Interface Description
Effluent Cleanup Control System	Provides instrumentation and control, and logics.
Process Radiation and Environmental Monitoring Systems (PREMS)	D11 provides sampling, area monitoring, and monitors liquid discharge.
CRD for High Pressure Injection	CST provides continuous water to purge CRD when the Hotwell and the condensate systems are not available.
SDC	SDC provides a reactor water reject path for cleanup and overboarding to LWMS when normal flow paths (e.g., CUW) are not in service.
CUW	Overboarding flow from CUW to the RWST / Collection Tanks/Sample Tanks.
Fuel Pool Cooling and Cleanup System (FPC)	CST provides water supply to FPC to maintain pool level.
Control Panel System	Local Control Panels provided for operation of skids and system pumps.
SWMS	Oily and solid wastes are collected and sent to the SWMS drum evaporator for dewatering and disposal.
CFS	CFS rejects water to the CST to control hotwell level.
Condensate Filters and Demineralizers System (CFD)	CST provides water supply to the CFD for use.
Main Condenser and Auxiliaries (MCA)	CST provides hotwell makeup.
Circulating Water System (CWS)	CWS accepts LWMS effluent discharge to environment.
Plant Pneumatics System (PPS)	Provides air needed to air operate valves and dewatering pump for control of the system.
Non-Safety Electrical Distribution System	Provides Non-Safety Category power.
Primary Containment Vessel and Systems	CST will provide water to inside containment for outages. Containment isolation valves are required.
Heating, Ventilation and Cooling System (HVAC)	LWMS Tank vents are discharged into the respective building exhaust system.
EFS	EFS collects and pumps radioactive liquid effluent to the collection tanks.
Water, Gas, and Chemical Pads (WGC) System	The WGC provides temporary makeup water during the shutdown/refuelling/startup mode when required by the increases in plant water demand.

NEDO-34174 Revision A

Table 11-2: SWMS Interfaces

Interfacing System	Interface Description
Effluent Cleanup Control System	Provides instrumentation and control, and logics.
PREMS	PRM monitors radioactivity in SWMS.
ICC	ICC resin is sent to the spent resin tank.
FPC	FPC resin is sent to the spent resin tank. Filter backwash water is sent to the sludge tanks.
LWMS	Spent resin from LWMS is sent to spent resin storage tank. Filter sludge and backwash sent to sludge tanks.
EFS	Collects liquid waste from SWM
PPS	PPS supplies instrument air to the SWMS Air Operated Valves (AOVs), decant and dewatering pumps. Service Air for backflushing decant line strainers.
Non-Safety Electrical Distribution System	Supplies power to SWMS.
HVAC	SWMS vents to local HVAC system.
CFD	CFD resin is sent to the spent resin tank. Backwash water is sent to the sludge tanks.

NEDO-34174 Revision A

Table 11-3: OGS Interfaces

Interfacing System	Interface Description
Turbine Auxiliary Steam Supply (TASS)	TASS steam is provided to the OGS to heat the effluent entering the Preheater.
PREMS	Offgas effluent to be sampled and monitored by PREMS downstream of dryers and prior to release to ensure offgas radiation content is below the acceptable release limit.
CFS	CFS reactor condensate water flows through the tube side of the Offgas Condenser. Effluent heat is rejected to the N21 condensate.
MCA	Effluent gases (including air in leakage and noncondensable gases) and dilution steam from the N61 SJAEs flow directly to OGS. Condensed water from offgas preheater tube side (originating from main steam) and from the offgas condenser shell side (originating from the dilution steam from the SJAEs) is drained to the main condenser.
Chilled Water Equipment	Chilled water is used to provide cooling to the Cooler Condenser and to the cooling coils in the Charcoal Vault HVAC system. Chilled water flows through the equipment then returns directly to Chilled Water Equipment.
Hydrogen Water Chemistry (HWC)	HWC infection control. Hydrogen and oxygen monitoring and control signal.
PPS	Motive air for AOV valve control provided by PPS. Nitrogen flow to purge Charcoal Tanks during maintenance periods.
Standby Power System	Standby Power System to provide power to SC3 electrical loads in OGS.
HVAC	Exhaust heat from offgas equipment (Refrigeration dryers and Charcoal Vault cooling), offgas effluent release.
EFS	Water condensed from the effluent in the Cooler Condenser, through the Moisture Separator and the Refrigeration Dryers, are drained to EFS.
TB Structure	Some OGS equipment housed with TB.
Radwaste Building Structure	Some OGS equipment housed with radwaste building.

NEDO-34174 Revision A

Table 11-4: PRM Interfaces

Interfacing System	Interface Description
Digital Control and Information Systems (DCIS)	PREMS: DCIS SC1, Safety Class 2 (SC2), SC3, and Non-Safety Class (SCN) instrumentation communication.
ICC	PRM: Radiation monitoring of the IC pools.
LWMS	PRM: Radiation monitoring of discharge to the CWS.
OGS	PRM: Radiation monitoring of the Pre-Treatment, Post-Treatment, and Charcoal Ventilation streams.
Main Turbine Equipment	PRM: Radiation monitoring of the gland seal steam condenser exhaust.
CWS	PRM: Radiation monitoring downstream of each Plant Cooling Water System (PCW) heat exchanger.
Containment Inerting System (CIS)	PRM: Radiation monitoring of the containment inerting exhaust. CMon: Monitoring of containment pressure and oxygen concentration (used for CIS inerting, de-inerting and make-up control).
HVAC	PRM: Radiation monitoring of the: <ul style="list-style-type: none"> • RB HVAC Intake • RB HVAC Exhaust • Refuel Floor/Fuel Pool Area HVAC Exhaust • TB HVAC Exhaust • Plant Services Area (PLSA) HVAC Exhaust • Plant Vent Stack • CB HVAC Intake • RWB HVAC Exhaust.

NEDO-34174 Revision A

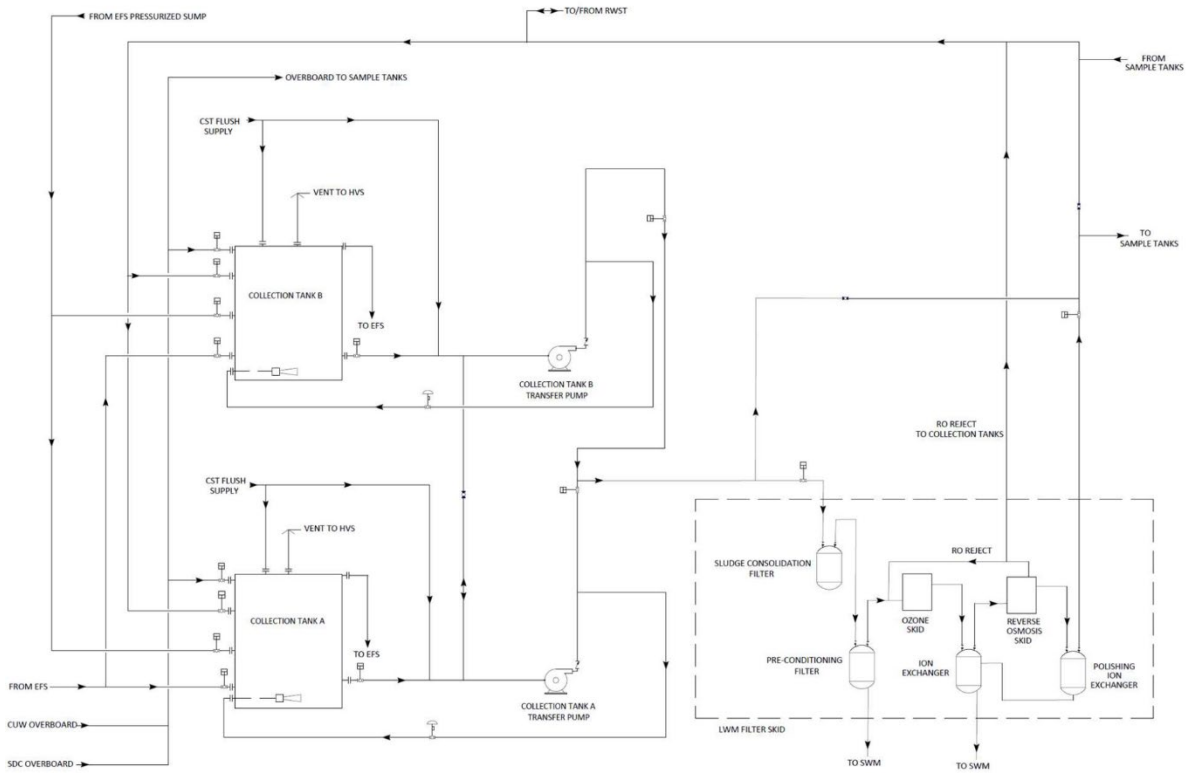

Figure 11-1: LWMS Waste Collection and Filtering Subsystem Simplified Diagram

NEDO-34174 Revision A

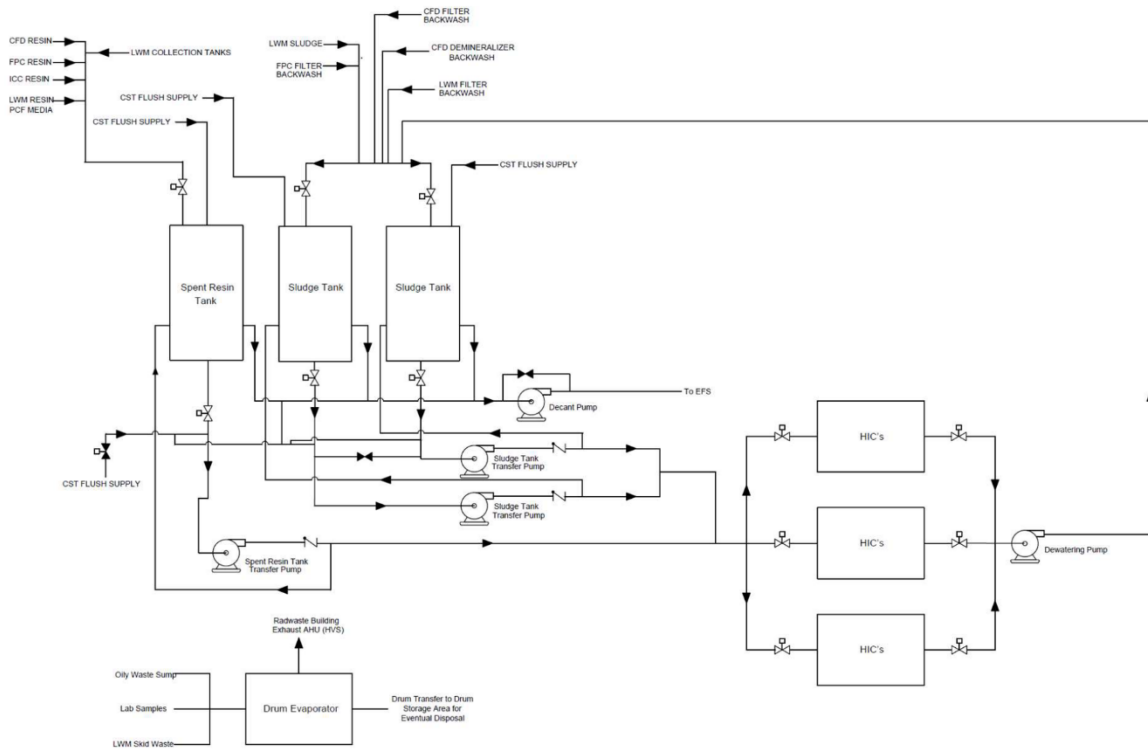

Figure 11-2: Solid Waste Management System Simplified Diagram

NEDO-34174 Revision A

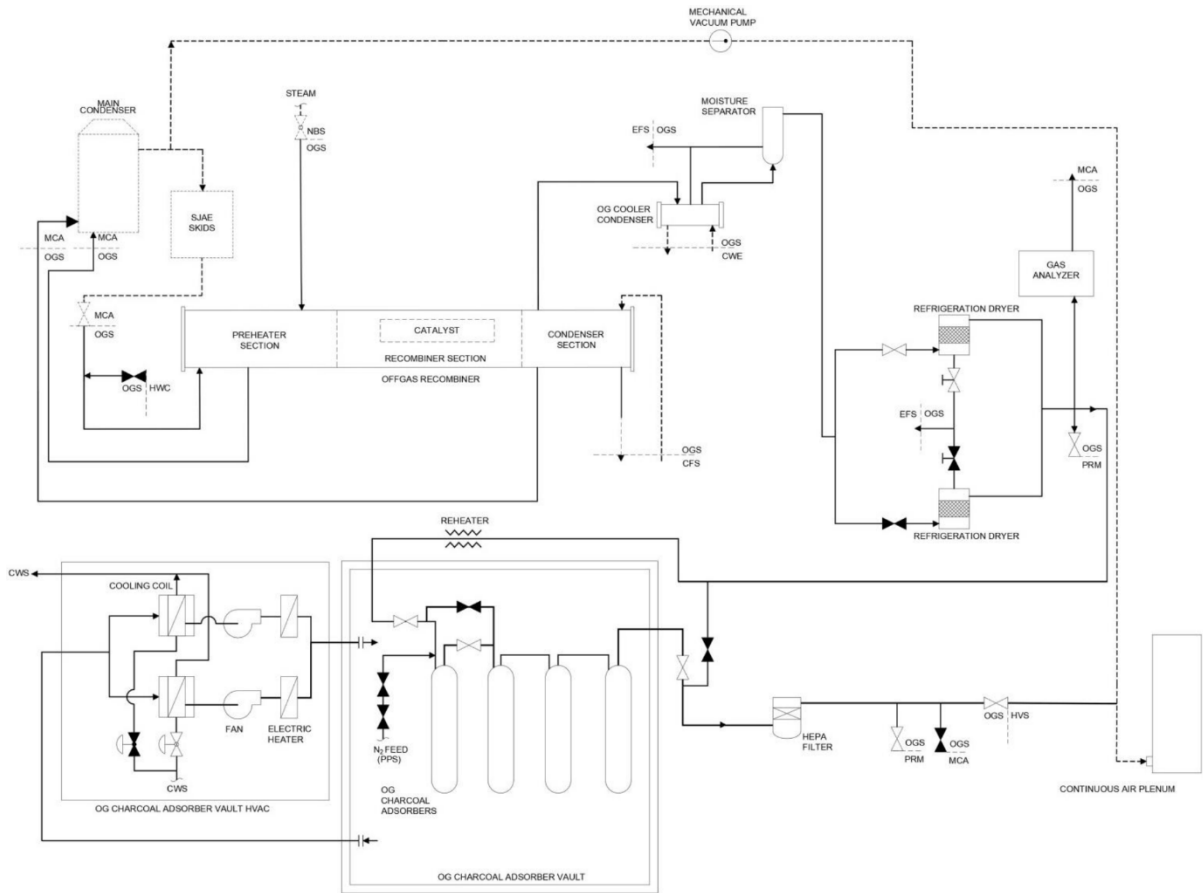

Figure 11-3: Simplified Diagram of the OGS System

NEDO-34174 Revision A

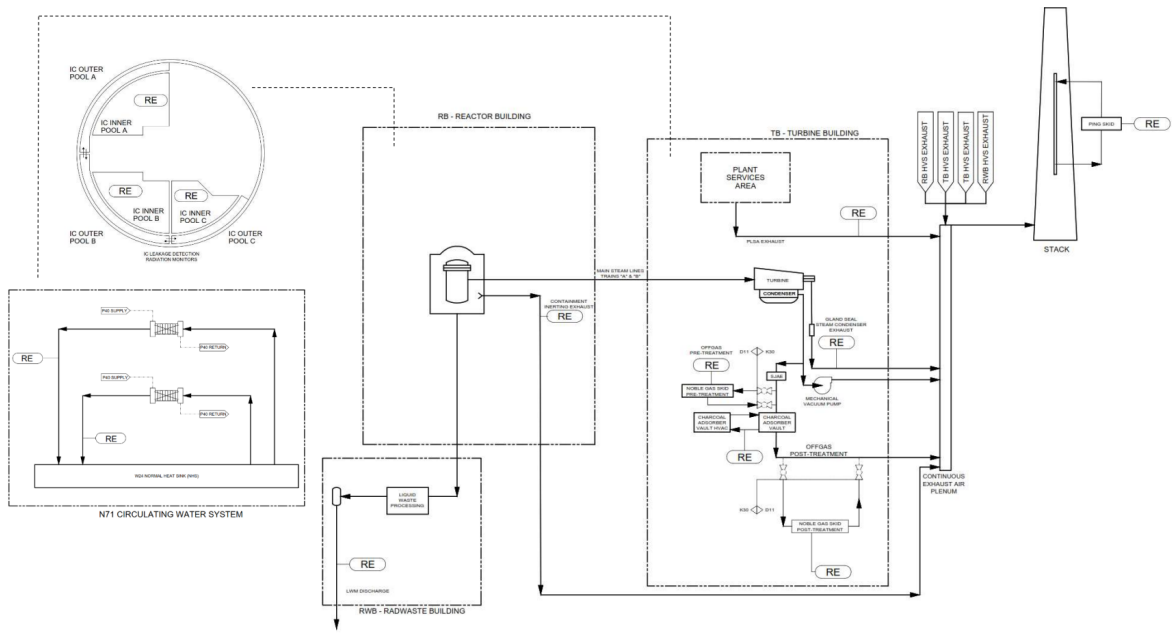

Figure 11-4: Process Radiation Monitoring Subsystem Simplified Diagram

NEDO-34174 Revision A

11.6 References

- 11-1 NEDC-34165P, "BWRX-300 UK GDA Preliminary Safety Report, Ch. 3: Safety Objectives and Design Rules for SSCs," Rev A, GE-Hitachi Nuclear Energy, Americas, LLC.
- 11-2 NEDC-34175P, "BWRX-300 UK GDA Preliminary Safety Report, Ch. 12: Radiation Protection," Rev A, GE-Hitachi Nuclear Energy, Americas, LLC.
- 11-3 NEDC-34193P, "BWRX-300 UK GDA Preliminary Safety Report, Ch. 21: Decommissioning and End of Life Aspects," Rev A, GE-Hitachi Nuclear Energy, Americas, LLC.
- 11-4 NEDC-34195P, "BWRX-300 UK GDA Preliminary Safety Report, Ch. 23: Reactor Chemistry," Rev A, GE-Hitachi Nuclear Energy, Americas, LLC.
- 11-5 NEDC-34198P, "BWRX-300 UK GDA Preliminary Safety Report, Ch. 26: Interim Storage of Spent Fuel," Rev A, GE-Hitachi Nuclear Energy, Americas, LLC.
- 11-6 NEDC-34221P, "BWRX-300 UK GDA Preliminary Environmental Report, Ch. E4: Information about the Design," Rev A, GE-Hitachi Nuclear Energy, Americas, LLC.
- 11-7 NEDC-34222P, "BWRX-300 UK GDA Preliminary Environmental Report, Ch. E5: Radioactive Waste Management Arrangements," Rev A, GE-Hitachi Nuclear Energy, Americas, LLC.
- 11-8 NEDC-34223P, "BWRX-300 UK GDA Preliminary Environmental Report, Ch. E6: Demonstration of BAT Approach," Rev A, GE-Hitachi Nuclear Energy, Americas, LLC.
- 11-9 NEDC-34224P, "BWRX-300 UK GDA Preliminary Environmental Report, Ch. E7: Quantification of Radioactive Discharges," Rev A, GE-Hitachi Nuclear Energy, Americas, LLC.
- 11-10 NEDC-34226P, "BWRX-300 UK GDA Preliminary Environmental Report, Ch. E9: Prospective Radiological Assessment," Rev A, GE-Hitachi Nuclear Energy, Americas, LLC.
- 11-11 006N6766, "BWRX-300 Water Quality – Technical Requirements Specification," Rev 4, GE-Hitachi Nuclear Energy, Americas, LLC, March 2024.
- 11-12 006N7733, "BWRX-300 Solid Waste Management System (SWMS) System Design Description," Rev 1, GE-Hitachi Nuclear Energy, Americas, LLC, April 2023.
- 11-13 006N7729, "BWRX-300 Liquid Waste Management System (LWMS) System Design Description," Rev 1, GE-Hitachi Nuclear Energy, Americas, LLC, April 2023.
- 11-14 006N7673, "BWRX-300 Water Balance Model," Rev B, GE-Hitachi Nuclear Energy, Americas, LLC, October 2022.
- 11-15 NEDC-34279P, "BWRX-300 Analysis of Environmental Discharge Data for US Nuclear Power Plants," Rev 0, GE-Hitachi Nuclear Energy, Americas, LLC.
- 11-16 008N0133, "BWRX-300 Solid Waste Management System - Contained Source Activity," Rev 0, GE-Hitachi Nuclear Energy, Americas, LLC, January 2024.
- 11-17 006N7899, "BWRX-300 Offgas System Design Description," Rev 1, GE-Hitachi Nuclear Energy, Americas, LLC, August 2023.
- 11-18 006N7938, "BWRX-300 Process and Radiation Environmental Monitoring System Design Description," Rev 2, GE-Hitachi Nuclear Energy, Americas, LLC.
- 11-19 NEDC-34140P, "BWRX-300 UK GDA Safety Case Development Strategy," Rev 3, GE-Hitachi Nuclear Energy, Americas, LLC.

NEDO-34174 Revision A

- 11-20 NEDC-34178P, "BWRX-300 UK GDA Preliminary Safety Report, Ch. 15: Safety Analysis (Including Fault Studies, PSA and Hazard Assessment)," Rev 0, GE-Hitachi Nuclear Energy, Americas, LLC.
- 11-21 "UK Strategy for the Management of Solid Low Level Radioactive Waste from the Nuclear Industry," DECC (on behalf of UK Government and Devolved Administrations), January 2015.
- 11-22 "The Management of Higher Activity Radioactive Waste on Nuclear Licensed Sites, Joint Guidance from the ONR, the EA, the Scottish EPA and NRW to Nuclear Licensees," Rev 2.1, ONR, EA, SEPA and NRW, July 2021.
- 11-23 "Industry Guidance: Interim Storage of Higher Activity Waste Packages – Integrated Approach," Issue 4, NDA, December 2021.
- 11-24 "Waste and Spent Fuel Storage Safety Reference Levels," Version 2.3, WENRA, January 2024.
- 11-25 No.SSG-40, "Predisposal Management of Radioactive Waste from Nuclear Power Plants and Research Reactors," IAEA, 2016.
- 11-26 "National Low Level Waste (LLW) Programme and Strategy," Rev 2, Nuclear Waste Services, November 2021.
- 11-27 NEDC-34228P, "BWRX-300 UK GDA Integrated Waste Strategy," Rev 1, GE-Hitachi Nuclear Energy, Americas, LLC.

NEDO-34174 Revision A

APPENDIX A Claims, Arguments and Evidence

The Claims, Argument and Evidence (CAE) approach can be explained as follows:

1. Claims (assertions) are statements that indicate why a facility is safe
2. Arguments (reasoning) explain the approaches to satisfying the claims
3. Evidence (facts) supports and forms the basis (justification) of the arguments

The GDA CAE structure is defined within document NEDC-34140P, “BWRX-300 UK GDA Safety Case Development Strategy,” (Reference 11-19) and is a logical breakdown of an overall claim that:

“The BWRX-300 is capable of being constructed, operated and decommissioned in accordance with the standards of environmental, safety, security and safeguard protection required in the UK”.

This overall claim is broken down into Level 1 claims relating to environment, safety, security, and safeguards, which are then broken down again into Level 2 area related sub-claims and then finally into Level 3 (chapter level) sub-claims.

The Level 3 sub-claims that this chapter demonstrates compliance against are identified within the SCDS (Reference 11-19) and are as follows:

- 2.1.2 *The design of the system/structure has been substantiated to achieve the safety functions in all relevant operating modes.*
- 2.1.3 *The system/structure design has been undertaken in accordance with relevant design codes and standards (RGP) and design safety principles and taking account of Operating Experience to support reducing risks ALARP.*
- 2.1.4 *System/structure performance will be validated by suitable testing throughout manufacturing, construction, and commissioning.*
- 2.1.5 *Ageing and degradation mechanisms will be identified and assessed in the design. Suitable examination, inspection, maintenance, and testing will be specified to maintain systems/structures fit-for-purpose through life.*
- 2.1.6 *The BWRX will be designed so that it can be decommissioned safely, using current available technologies, and with minimal impact on the environment and people.*
- 2.4.1 *Relevant Good Practice (RGP) has been taken into account across all disciplines.*
- 2.4.2 *Operational Experience (OPEX) and Learning from Experience (LfE) has been taken into account across all disciplines.*
- 2.4.3 *Optioneering (all reasonably practicable measures have been implemented to reduce risk).*

In order to facilitate compliance, demonstration against the above Level 3 sub-claims, this PSR chapter has derived a suite of arguments that comprehensively explain how their applicable Level 3 sub-claims are met (see Table A-1 below).

It is not the intention to generate a comprehensive suite of evidence to support the derived arguments, as this is beyond the scope of GDA Step 2. However, where evidence sources are available, examples are provided.

NEDO-34174 Revision A

A.1 Risk Reduction As Low As Reasonably Practicable

It is important to note that nuclear safety risks cannot be demonstrated to have been reduced ALARP within the scope of a 2-Step GDA. It is considered that the most that can be realistically achieved is to provide a reasoned justification that the BWRX-300 Small Modular Reactor (SMR) design aspects will effectively contribute to the development of a future ALARP statement. In this respect, this chapter contributes to the overall future ALARP case by demonstrating that:

- The chapter-specific arguments derived may be supported by existing and future planned evidence sources covering the following topics:
 - Relevant Good Practice (RGP) has demonstrably been followed
 - OPEX has been taken into account within the design process
 - All reasonably practicable options to reduce risk have been incorporated within the design
- It supports its applicable level 3 sub-claims, defined within the SCDS (Reference 11-19)

Probabilistic safety aspects of the ALARP argument are addressed within NEDC-34178P, “BWRX-300 UK GDA Preliminary Safety Report, Ch. 15: Safety Analysis (Including Fault Studies, PSA and Hazard Assessment),” (Reference 11-20).

NEDO-34174 Revision A

Table A-1: Claims, Arguments and Evidence

Level 11 Chapter Claim	Chapter 11 Argument	Sub-Sections and/or Reports that Evidence the Arguments
<p>2.1 The functions of systems and structures have been derived and substantiated taking into account RGP and OPEX, and processes are in place to maintain these through-life. (Engineering Analysis).</p>		
<p>2.1.2 The design of the system/structure has been substantiated to achieve the safety functions in all relevant operating modes.</p>	<p>The UK BWRX-300 design has been substantiated from the United States (U.S.) and Canadian BWRX-300 principles with the consideration of UK context.</p>	<p>Subsections 11.2.1, 11.2.2, 11.3.1, 11.3.2, 11.4.1,11.4.2, 11.5.1, and 11.5.2</p>
<p>2.1.3 The system/structure design has been undertaken in accordance with relevant design codes and standards (RGP) and design safety principles, and taking account of Operating Experience to support reducing risks ALARP.</p>	<p>The BWRX-300 radioactive waste management systems have been designed to the U.S. and Canadian nuclear regulatory requirements, along with international good practice. OPEX from previous US BWRs has been considered in the design of the BWRX-300 radioactive waste management systems.</p>	<p>Subsections 11.2.3, 11.2.6, 11.2.9, 11.3.3, 11.4.3, and 11.5.3 Document NEDC-34279P, "Analysis of Environmental Discharge Data for US Nuclear Power Plants" (Reference 11-15) Document NEDC-34222P, PER "Ch. E5: Radioactive Waste Management Arrangements" (Reference 11-7)</p>
<p>2.1.4 System/structure performance will be validated by suitable testing throughout manufacturing, construction and commissioning.</p>	<p>The BWRX-300 design has been assessed for development at Darlington, Canada, and the Tennessee Valley, U.S. The UK BWRX-300 shall undergo further future validation and fault studies will be undertaken prior to construction of the radioactive waste management systems.</p>	<p>Subsections 11.2.3, 11.2.6, 11.3.3, 11.3.6, 11.4.3, 11.4.6, 11.5.3, and 11.5.6</p>

NEDO-34174 Revision A

Level 11 Chapter Claim	Chapter 11 Argument	Sub-Sections and/or Reports that Evidence the Arguments
2.1.5 Ageing and degradation mechanisms will be identified and assessed in the design. Suitable examination, inspection, maintenance and testing will be specified to maintain systems/structures fit-for-purpose through life.	Radioactive waste management systems will be monitored during operation as well as gaseous and liquid streams. GNF2 fuel assemblies have been designed to minimise degradation during operation and evaluated for interim storage of up to 40 years.	Subsections 11.2.8, 11.3.8, 11.4.8, and 11.5 Document NEDC-34198P, PSR “PSR Ch. 26 Interim Storage of Spent Fuel” (Reference 11-5)
2.1.6 The BWRX will be designed so that it can be decommissioned safely, using current available technologies, and with minimal impact on the environment and people.	The BWRX-300 design is based on RP OPEX, BAT and ALARP principles, including with respect to decommissioning. This is aided by the modular design, material choices, SSCs design and continually evolving knowledge of international RGP of decontamination and dismantling methods.	Document NEDC-34193P, PSR “PSR Ch. 21: Decommissioning and End of Life Aspects” (Reference 11-3)
2.4 Safety risks have been reduced ALARP		
2.4.1 RGP has been taken into account across all disciplines.	The radioactive waste management design requirements have been derived in accordance with general design and safety principles. The SC of the radioactive waste management systems and their components have been derived from general design and safety principles.	Sections 11.2, 11.3, 11.4, and 11.5 Appendix C
2.4.2 OPEX and LfE has been taken into account across all disciplines.	Experience from U.S. BWR has been considered during the design of BWRX-300. LWMS design based on design at TEPCO Fukushima site.	Subsections 11.2.6 and 11.2.9

NEDO-34174 Revision A

Level 11 Chapter Claim	Chapter 11 Argument	Sub-Sections and/or Reports that Evidence the Arguments
2.4.3 Optioneering (all reasonably practicable measures have been implemented to reduce risk).	Design improvements have been considered and any reasonably practicable changes implemented.	Sections 11.2, 11.3, 11.4, and 11.5

NEDO-34174 Revision A

APPENDIX B Forward Action Plans

No forward actions have been derived in this chapter. All forward actions applicable to this chapter are available in NEDC-34222P, PER Ch. E5 (Reference 11-7).

NEDO-34174 Revision A

APPENDIX C UK Specific Context Information

UK Regulatory Context

The general principles and methodology relevant to the selection of appropriate codes and standards is presented in NEDC-34165P, PSR Ch. 3 (Reference 11-1). The codes and standards (including RGP) applicable for radioactive waste management are identified from the following sources:

- UK Act, Regulations and Government policies and strategies; and
- Guidance/documents issued by international and UK organisations, such as International Atomic Energy Agency, Western European Nuclear Regulators Association, Office for Nuclear Regulation (ONR), Environment Agency, etc.

The main policies and regulations that relate to waste management are identified below:

- The Health and Safety at Work Act, 1974.
- The Nuclear Installations Act, 1965.
- The Ionising Radiations Regulations, 2017.
- Hazardous Waste Regulations, 2005.
- The Environmental Permitting (England and Wales) Regulations, 2016.
- The Environment Act, 1995.
- UK Strategy for Radioactive Discharges, 2011-2020.
- Review of radioactive waste management policy: Final Conclusions (Cmnd 2919).
- Policy for the Long-Term Management of Solid Low Level Radioactive Waste in the United Kingdom, 2007.

Guidance and documents issued by international and UK organisations (considered RGP) include:

- A) "UK Strategy for the Management of Solid Low Level Radioactive Waste from the Nuclear Industry" (Reference 11-21).
- B) "The Management of Higher Activity Radioactive Waste on Nuclear Licensed Sites" (Reference 11-22).
- C) "Industry Guidance: Interim Storage of Higher Activity Waste Packages – Integrated Approach" (Reference 11-23).
- D) "Waste and Spent Fuel Storage Safety Reference Levels" (Reference 11-24).
- E) "Predisposal Management of Radioactive Waste from NPP and Research Reactors" (Reference 11-25).
- F) "National Low Level Waste (LLW) Programme and Strategy" (Reference 11-26).

The NEDC-34228P, "BWRX-300 UK GDA Integrated Waste Strategy," (Reference 11-27) provides greater detail on the UK requirements for management of radioactive wastes, relating to applicable government policy and strategy, legislation and related regulations, and relevant good practice guidance. NEDC-34222P, PER Ch. E5 (Reference 11-7) demonstrates how the BWRX-300 radioactive wastes can be aligned to UK practices and processes that enable compliance with those requirements.